

(No Model.)

# E. B. & D. S. WHITE.

APPARATUS FOR GATHERING AND LOADING MANURE, &c.

No. 251,394.

Patented Dec. 27, 1881

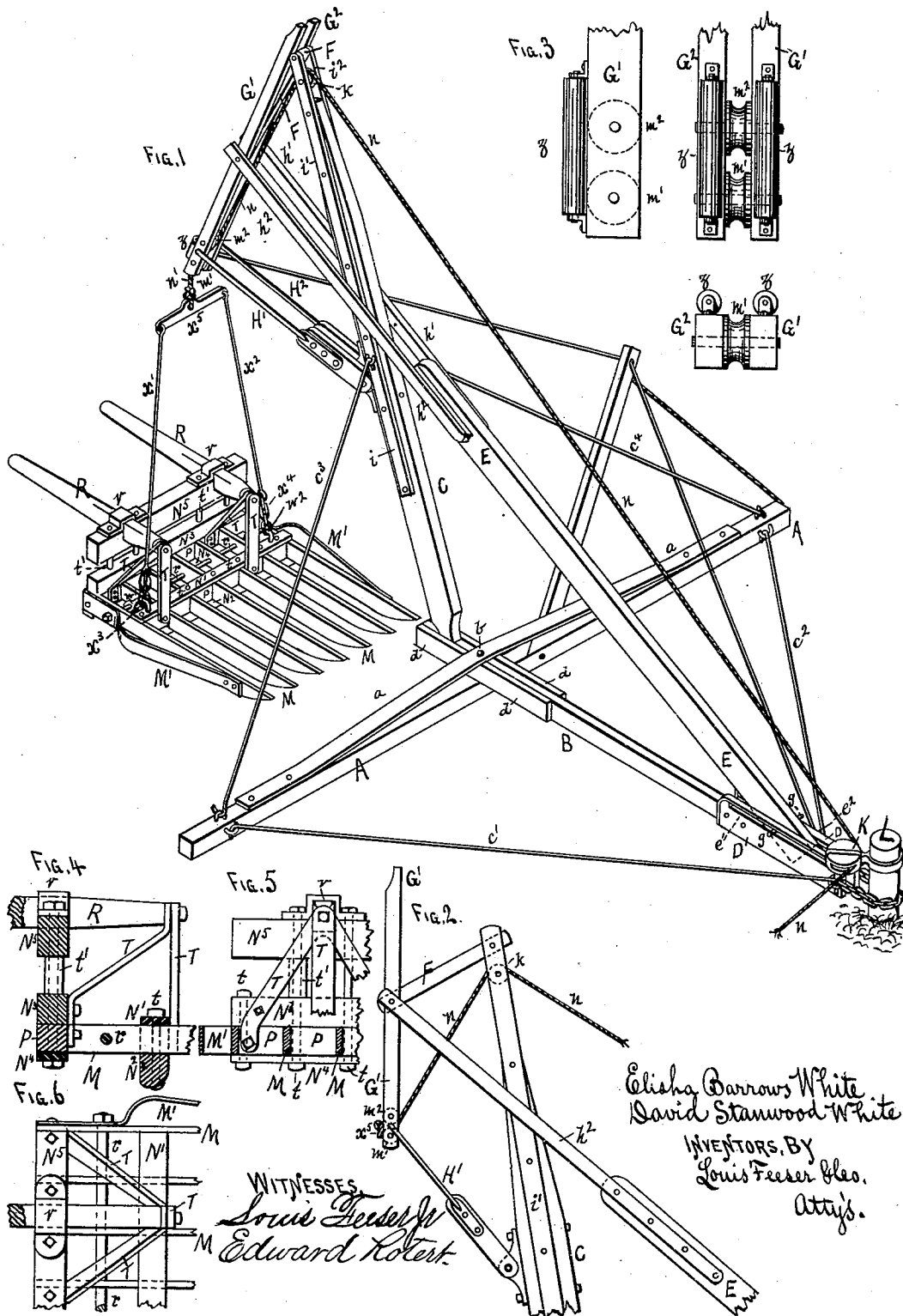

WITNESSES  
*Louis Feiser*  
*Edward Lotest*

Elisha Barrows White  
David Stanwood White  
INVENTORS, BY  
Louis Feiser & Co.  
Attys.

# UNITED STATES PATENT OFFICE.

ELISHA B. WHITE, OF MINNEAPOLIS, AND DAVID S. WHITE, OF NORTHFIELD, MINNESOTA.

## APPARATUS FOR GATHERING AND LOADING MANURE, &c.

SPECIFICATION forming part of Letters Patent No. 251,394, dated December 27, 1881.

Application filed November 9, 1881. (No model.)

To all whom it may concern:

Be it known that we, ELISHA BARROWS WHITE, a resident of Minneapolis, Hennepin county, Minnesota, and DAVID STANWOOD WHITE, a resident of Northfield, Rice county, Minnesota, both being citizens of the United States, have invented a new and useful Improvement in Apparatus for Gathering and Loading Manure, &c., of which the following is a specification.

This invention relates to apparatus to facilitate the gathering and loading of manure, &c., from the ground in stable-yards, &c.; and it consists in an adjustable portable derrick and a gathering-fork and in the manner of constructing and operating them, as hereinafter set forth.

Figure 1 is a perspective view of the derrick and fork complete. Fig. 2 is a side view of the upper part of the derrick, showing its position when the "boom" is elevated. Fig. 3 are detached detail views of the lower end of the pivoted boom end, showing the manner of arranging the rope-sheaves and friction-rollers; Figs. 4, 5, and 6, enlarged detached views of portions of the gathering-fork head, illustrating the manner of its construction.

A is a base-timber, across which, at the center and at right angles thereto, another timber, B, rests with its forward end projecting a short distance beyond the timber A, and in which short projection the lower end of the main timber C of a mast is stepped.

a is a thin metal or wooden strap, secured at either end to the base-timber A, and running over the top of the base-timber B, as shown, and down through which and the two timbers a pivot-bolt, b, passes to hold them all together, while brace-rods c' c', connecting the ends of the timbers together, act as braces to keep them in their relative positions, while similar braces, c<sup>2</sup> c<sup>2</sup>, perform the same office for the mast. Side pieces d upon the forward end of the timber B serve to strengthen the step for the mast. The rear end of the timber B is provided with side pieces D, in which slots e' e<sup>2</sup> are formed for the reception of a pin, g, passing through the lower end of a main timber, E, of a boom, as shown. By this means the lower end of the boom is free to play back and forth, as hereinafter described.

The boom consists of a main timber, E, running up nearly to the mast C, and from thence in two pieces h' h<sup>2</sup>, passing one on each side of the mast C, and connected to the upper part of the mast by a short arm, F.

The mast consists of a main timber, C, upon the sides of which two smaller pieces, i' i<sup>2</sup>, are secured, and running up above the timber C, and between their ends the upper end of the arm F, and a sheave, k, are pivoted, as shown.

G' G<sup>2</sup> are two pieces pivoted, near their centers, between the ends of the pieces h' h<sup>2</sup>, and having the bar F pivoted between them, one bolt thus holding all four pieces. The upper ends of the pieces G' G<sup>2</sup> rest against the upper ends of the pieces h' h<sup>2</sup> when in the position shown in Fig. 1, while their centers are connected to the main timber C of the mast by pivoted bars H' H<sup>2</sup>. In the lower ends of the bars G' G<sup>2</sup> two chain or rope sheaves, m' m<sup>2</sup>, are pivoted, between which the hoisting-rope n passes, and thence up over the sheave k and down to a block, K, attached to a post, L, or otherwise secured, and thence to the horses or other power to be used to operate it. The rear end of the timber B is also secured loosely to this same post L, or to any other object, so that it is free to swing around it as a pivot, so that the derrick may be made to face in any desired direction. By thus constructing the derrick it may be easily and quickly disconnected and packed into a small compass for transportation.

The fork consists of steel teeth M, held at their rear ends by top and bottom plates, N' N<sup>2</sup> N<sup>3</sup> N<sup>4</sup>, and dividing-blocks P, the whole being held together laterally by a tie-bolt, r, between the two sets of plates N' N<sup>2</sup> and N<sup>3</sup> N<sup>4</sup>, and perpendicularly by small bolts t passing down through the two sets of plates and the blocks P, as shown. By this means the whole fork is firmly held together, and may be easily and quickly tightened up when the teeth become loose, or a broken tooth or other part very easily and quickly replaced. The upper plate, N', of the forward set and the lower plate, N<sup>4</sup>, of the rear set will be of metal, while the other plates, N<sup>2</sup> N<sup>3</sup>, and the blocks P will be of wood, thus combining strength with lightness. Outside the end teeth, M, curved metal braces M' will be secured, to

strengthen the fork and prevent the end teeth being bent off sidewise. Above the rear plates,  $N^3 N^4$ , a short distance, is another plate or bar,  $N^5$ , connected to the plate  $N^3$  by standards  $t'$  and bolts. Across the top of this bar handles  $R$  are secured by straps  $v$ , the bolts of these straps, and also of the standards  $t'$ , being two of the bolts  $t$ , that secure the bars  $N^3 N^4$  and rear set of blocks  $P$  together, extended, so that said bolts are utilized for double duty.

There are braces connecting the forward ends of the handles  $R$  to the plates  $N^2 N^3$ , so that the handles are firmly connected to the fork.

$w' w^2$  are small curved bolts, encircling the tie-rod  $r$ , and running down through the plates  $N' N^2$ , to which the lower ends of the bail for operating the fork are attached. This bail consists of two side rods,  $x' x^2$ , connected at their lower ends by short chains  $x^3 x^4$  to the rods  $w' w^2$ , and at their tops to one common cross-bar,  $x^5$ , to the center of which the hoisting-rope  $n$  is attached, as shown. The cross-bar  $x^5$  will be so arranged that when the fork is raised up it will pass in front of the lower ends of the pieces  $G' G^2$ , as shown in Fig. 2, thus preventing the fork from turning around after it is hoisted up, so that the load may be properly dumped.

The braces  $H' H^2$  consist partially of wood and partially of iron rods, as shown, so that less obstruction to the raising of the fork will occur, while at the same time strength and lightness are secured.

When the fork is to be used the rear end of the base-timber  $B$ , as before described, is connected loosely to the stake or post  $L$ , or large stone, stump, or other suitable object in one corner of the barn-yard, and the derrick set to face the point at which it is desired to commence operations. The fork is then taken to the proper point, and by drawing upon the rope  $n$  and holding up the rear end of the fork by the handles  $R$  the fork will be drawn up to the derrick and rake all the manure, &c., in its path. The wagon or other receptacle for the manure having been placed beneath the pieces  $G' G^2$  and  $H' H^2$  in front of the mast  $C$ , the fork, with its load, after it comes beneath the pieces  $G' G^2$ , will be hoisted straight up until the cross-bar  $x^5$  strikes across the pieces  $G' G^2$ , as shown in Fig. 2, which will bring the fork above the wagon. The strain on the cord  $n$  will then draw the boom and bars  $G', G^2, H', H^2$ , and  $F$  backward, (the lower end of the boom running back in the slots  $e' e^2$ .) as shown in Fig. 2, and thus draw the fork and its load inward over the wagon, this latter feature of drawing the fork inward over the wagon after

being hoisted up being the object of this peculiar arrangement of the arms and levers  $G', G^2, H', H^2$ , and  $F$ , and the slots  $e' e^2$  and pin  $g$ . After being dumped the fork is allowed to drop down again, when the parts  $G' G^2 H' H^2 F$  will resume the position shown in Fig. 1, ready for another load.

Small rollers  $z z$  will be arranged upon the faces of the pieces  $G' G^2$ , opposite the sheaves  $m' m^2$ , over which the rope  $n$  runs when the fork is drawn to one side of the derrick, as is frequently the case, to prevent unnecessary friction.

What we claim as new is—

1. The combination and arrangement of the base-timbers  $A B$ , mast  $C$ , and boom  $E$ , substantially as set forth.

2. The combination and arrangement of the base  $A B$ , brace-strap  $a$ , and mast  $C$ , substantially as set forth.

3. The combination and arrangement of the base  $A B$ , boom  $E$ , mast  $C$ , and brace-rods  $c' c^2 c^3 c^4$ , substantially as set forth.

4. The combination and arrangement of the base-timber  $B$ , provided with the slots  $e' e^2$ , the boom  $E$ , and pin  $g$ , substantially as set forth.

5. The combination and arrangement of the mast  $C$ , having the side pieces  $i' i^2$ , boom  $E$ , having the side pieces  $h' h^2$ , and connecting-bars  $F' G' G^2 H' H^2$ , substantially as set forth.

6. The combination and arrangement of the connecting-bars  $G' G^2$ , sheaves  $m' m^2$ , and guide-rollers  $z z$ , substantially as set forth.

7. The combination and arrangement of the connecting-bars  $G' G^2$ , sheaves  $m' m^2$ , and cross-bar  $x^5$ , and rope  $n$ , substantially as set forth.

8. The fork consisting of the teeth  $M$ , head  $N' N^2 N^3 N^4 P$ , and connecting-rod  $r$ , and bolts  $t$ , substantially as set forth.

9. The combination and arrangement of the fork, constructed substantially as described, with cross-bar  $N^5$ , handles  $R$ , and braces  $T$ .

10. The combination and arrangement of the derrick and fork, constructed substantially as described, the bail consisting of the side rods,  $x' x^2$ , and cross-bar  $x^5$ , and the rope  $n$ .

11. The combination and arrangement of the fork-teeth  $M$  and braces  $M'$ , substantially as set forth.

In testimony whereof we have hereunto set our hands in the presence of two subscribing witnesses.

ELISHA BARROWS WHITE.  
DAVID STANWOOD WHITE.

Witnesses:

C. N. WOODWARD,  
LOUIS FEESER, Sr.