

646351

SPRUSON & FERGUSON

AUSTRALIA

PATENTS ACT 1990

PATENT REQUEST: STANDARD PATENT

I/We, the Applicant(s)/Nominated Person(s) specified below, request I/We be granted a patent for the invention disclosed in the accompanying standard complete specification.

[70,71] Applicant(s)/Nominated Person(s):

Compaq Computer Corporation, incorporated in Delaware, of 20555 S.H.
249, Houston, Texas, 77070, UNITED STATES OF AMERICA

[54] Invention Title:

High Density Ink Jet Printhead

[72] Inventor(s):

John R. Pies, David B. Wallace and Donald J. Hayes

[74] Address for service in Australia:

Spruson & Ferguson, Patent Attorneys
Level 33 St Martins Tower
31 Market Street
Sydney New South Wales Australia (Code SF)

	Details of Basic Application(s):	
[31] Appl'n No(s):	[33] Country:	[32] Application Date:
748,220	US	16 August 1991

DATED this THIRTEENTH day of AUGUST 1992

Compaq Computer Corporation

By:

Registered Patent Attorney

IRN: 218244

INSTR CODE: 52942

SPRUSON & FERGUSON

Australia

Patents Act 1990

NOTICE OF ENTITLEMENT

I, John Gordon Hinde, of Spruson & Ferguson, St Martins Tower, 31 Market Street, Sydney, New South Wales 2000, Australia, being the patent attorney for the Applicant/Nominated Person in respect of an application entitled:

High Density Ink Jet Printhead

state the following:-

The Applicant/Nominated Person has entitlement from the actual inventor(s) as follows:-

The Applicant/Nominated Person is the assignee of the actual inventor(s).

The Applicant/Nominated Person is entitled to rely on the basic application(s) listed on the Patent Request as follows:

The Applicant/Nominated Person is the assignee of the basic applicant(s).

The basic application(s) listed on the Patent Request is/are the application(s) first made in a Convention country in respect of the invention.

DATED this Twelfth day of August 1992

.....
John Gordon Hinde

IRN: 218244

INSTR CODE: 52942

1
KRS/665P



AU9221025

(12) PATENT ABRIDGMENT (11) Document No. AU-B-21025/92
(19) AUSTRALIAN PATENT OFFICE (10) Acceptance No. 646351

- (54) Title
HIGH DENSITY INK JET PRINTHEAD
- International Patent Classification(s)
(51)⁵ **B41J 002/16 B41J 002/14 B41J 002/045**
- (21) Application No. : **21025/92** (22) Application Date : **13.08.92**
- (30) Priority Data
- (31) Number (32) Date (33) Country
748220 16.08.91 US UNITED STATES OF AMERICA
- (43) Publication Date : **04.03.93**
- (44) Publication Date of Accepted Application : **17.02.94**
- (71) Applicant(s)
COMPAQ COMPUTER CORPORATION
- (72) Inventor(s)
JOHN R. PIES; DAVID B. WALLACE; DONALD J. HAYES
- (74) Attorney or Agent
SPRUSON & FERGUSON , GPO Box 3898, SYDNEY NSW 2001
- (56) Prior Art Documents
EP 372521
- (57) Claim

1. An ink jet printhead, comprising:

a base section formed from a piezoelectric material, said base section having a plurality of generally parallel spaced projections extending longitudinally along said base section, each of said projections having a top side;

a plurality of intermediate sections, each said intermediate section having a top side and a bottom side and a conductive mounting for mounting said plurality of intermediate sections on said top side of a corresponding one of said plurality of base section projections, each of said intermediate sections formed from a piezoelectric material; and

a top section having a conductive mounting for mounting said top section to said top side of each of said plurality of intermediate sections;

wherein said base section, said plurality of intermediate sections and said top section define a plurality of generally parallel, axially extending ink-carrying channels from which ink may be ejected therefrom.

646351

S & F Ref: 218244

**AUSTRALIA
PATENTS ACT 1990**

COMPLETE SPECIFICATION

FOR A STANDARD PATENT

ORIGINAL

Name and Address
of Applicant: Compaq Computer Corporation
20555 S.H. 249
Houston Texas 77070
UNITED STATES OF AMERICA

Actual Inventor(s): John R. Pies, David B. Wallace and Donald J. Hayes

Address for Service: Spruson & Ferguson, Patent Attorneys
Level 33 St Martins Tower, 31 Market Street
Sydney, New South Wales, 2000, Australia

Invention Title: High Density Ink Jet Printhead

The following statement is a full description of this invention, including the best method of performing it known to me/us:-

HIGH DENSITY INK JET PRINTHEAD

BACKGROUND OF THE INVENTION

Field of the Invention

5 The invention relates to a high density ink jet printhead and, more particularly, to a multiple channel, sidewall actuated high density ink jet printhead configured for cross-talk reduced operation.

Description of Related Art

10 Printers provide a means of outputting a permanent record in human readable form. Typically, a printing technique may be categorized as either impact printing or non-impact printing. In impact printing, an image is formed by striking an inked ribbon placed near the surface of the paper. Impact printing techniques may be further characterized as either formed-character printing or matrix printing. In formed-character printing, the element which strikes the ribbon to produce the image consists of a raised mirror image of the desired character. In matrix printing, the character is formed as a series of closely spaced dots which are produced by striking a provided wire or wires against the ribbon. Here, characters are

15

20

formed as a series of closely spaced dots produced by striking the provided wire or wires against the ribbon. By selectively striking the provided wires, any character representable by a matrix of dots can be produced.

5

Non-impact printing is often preferred over impact printing in view of its tendency to provide higher printing speeds as well as its better suitability for printing graphics and half-tone images. Non-impact printing techniques include matrix, electrostatic and electrophotographic type printing techniques. In matrix type printing, wires are selectively heated by electrical pulses and the heat thereby generated causes a mark to appear on a sheet of paper, usually specially treated paper. In electrostatic type printing, an electric arc between the printing element and the conductive paper removes an opaque coating on the paper to expose a sublayer of a contrasting color. Finally, in electrophotographic printing, a photoconductive material is selectively charged utilizing a light source such as a laser. A powder toner is attracted to the charged regions and, when placed in contact with a sheet of paper, transfers to the paper's surface. The toner is then subjected to heat which fuses it to the paper.

10

15

20

25

Another form of non-impact printing is generally classified as ink jet printing. Ink jet printing systems use the ejection of tiny droplets of ink to produce an image. The devices produce highly reproducible and controllable droplets, so that a droplet may be printed at a location specified by digitally stored image data. Most ink jet printing systems commercially available may be generally classified as either a "continuous jet"

30

35

type ink jet printing system where droplets are continuously ejected from the printhead and either directed to or away from the paper depending on the desired image to be produced or as a "drop on demand" type ink jet printing system where droplets are ejected from the printhead in response to a specific command related to the image to be produced.

Continuous jet type ink jet printing systems are based upon the phenomena of uniform droplet formation from a stream of liquid issuing from an orifice. It had been previously observed that fluid ejected under pressure from an orifice about 50 to 80 microns in diameter tends to break up into uniform droplets upon the amplification of capillary waves induced onto the jet, for example, by an electromechanical device that causes pressure oscillations to propagate through the fluid. For example, in FIG. 1, a schematic illustration of a continuous jet type ink jet printer 200 may now be seen. Here, a pump 202 pumps ink from an ink supply 204 to a nozzle assembly 206. The nozzle assembly 206 includes a piezo crystal 208 which is continuously driven by an electrical voltage supplied by a crystal driver 210. The pump 202 forces ink supplied to the nozzle assembly 206 to be ejected through nozzle 212 in a continuous stream. The continuously oscillating piezo crystal 208 creates pressure disturbances that cause the continuous stream of ink to break-up into uniform droplets of ink and acquire an electrostatic charge due to the presence of an electrostatic field, often referred to as the charging field, generated by electrodes 214. Using high voltage deflection plates 216, the trajectory of selected ones of the

5 electrostatically charged droplets can be
controlled to hit a desired spot on a sheet of
paper 218. The high voltage deflection plates 216
also deflect unselected ones of the
10 electrostatically charged droplets away from the
sheet of paper 218 and into a reservoir 220 for
recycling purposes. Due to the small size of the
droplets and the precise trajectory control, the
quality of continuous jet type ink jet printing
15 systems can approach that of formed-character
impact printing systems. However, one drawback to
continuous jet type ink jet printing systems is
that fluid must be jetting even when little or no
printing is required. This requirement degrades
the ink and decreases reliability of the printing
system.

Due to this drawback, there has been increased
interest in the production of droplets by
20 electromechanically induced pressure waves. In
this type of system, a volumetric change in the
fluid is induced by the application of a voltage
pulse to a piezoelectric material which is directly
or indirectly coupled to the fluid. This
volumetric change causes pressure/velocity
25 transients to occur in the fluid and these are
directed so as to produce a droplet that issues
from an orifice. Since the voltage is applied only
when a droplet is desired, these types of ink jet
printing systems are referred to as drop-on-demand.
30 For example, in FIG. 2, a drop on demand type ink
jet printer is schematically illustrated. A nozzle
assembly 306 draws ink from a reservoir (not
shown). A driver 310 receives character data and
actuates piezoelectric material 308 in response
35 thereto. For example, if the received character

5 data requires that a droplet of ink is to be ejected from the nozzle assembly 306, the driver 310 will apply a voltage to the piezoelectric material 308. The piezoelectric material will then deform in a manner that will force the nozzle assembly 306 to eject a droplet of ink from orifice 312. The ejected droplet will then strike a sheet of paper 318.

10 The use of piezoelectric materials in ink jet printers is well known. Most commonly, piezoelectric material is used in a piezoelectric transducer by which electric energy is converted into mechanical energy by applying an electric field across the material, thereby causing the
15 piezoelectric material to deform. This ability to distort piezoelectric material has often been utilized in order to force the ejection of ink from the ink-carrying channels of ink jet printers. One such ink jet printer configuration which utilizes
20 the distortion of a piezoelectric material to eject ink includes a tubular piezoelectric transducer which surrounds an ink-carrying channel. When the transducer is excited by the application of an electrical voltage pulse, the ink-carrying channel is compressed and a drop of ink is ejected from the
25 channel. For example, an ink jet printer which utilizes circular transducers may be seen by reference to U.S. Patent No. 3,857,049 to Zoltan. However, the relatively complicated arrangement of
30 the piezoelectric transducer and the associated ink-carrying channel causes such devices to be relatively time-consuming and expensive to manufacture.

35 In order to reduce the per ink-carrying channel (or "jet") manufacturing cost of an ink jet

5 printhead, in particular, those ink jet printheads
having a piezoelectric actuator, it has long been
desired to produce an ink jet printhead having a
channel array in which the individual channels
10 which comprise the array are arranged such that the
spacing between adjacent channels is relatively
small. For example, it would be very desirable to
construct an ink jet printhead having a channel
array where adjacent channels are spaced between
15 approximately four and eight mils apart. Such a
ink jet printhead is hereby defined as a "high
density" ink jet printhead. In addition to a
reduction in the per ink-carrying channel
manufacturing cost, another advantage which would
20 result from the manufacture of an ink jet printhead
with a high channel density would be an increase in
printer speed. However, the very close spacing
between channels in the proposed high density ink
jet printhead has long been a major problem in the
manufacture of such printheads.

Recently, the use of shear mode piezoelectric
transducers for ink jet printhead devices have
become more common. For example, U.S. Patent Nos.
4,584,590 and 4,825,227, both to Fischbeck et al.,
25 disclose shear mode piezoelectric transducers for
a parallel channel array ink jet printhead. In
both of the Fischbeck et al. patents, a series of
open ended parallel ink pressure chambers are
covered with a sheet of a piezoelectric material
30 along their roofs. Electrodes are provided on
opposite sides of the sheet of piezoelectric
material such that positive electrodes are
positioned above the vertical walls separating
pressure chambers and negative electrodes are
35 positioned over the chamber itself. When an

electric field is provided across the electrodes, the piezoelectric material, which is polled in a direction normal to the electric field direction, distorts in a shear mode configuration to compress the ink pressure chamber. In these configurations, however, much of the piezoelectric material is inactive. Furthermore, the extent of deformation of the piezoelectric material is small.

An ink jet printhead having a parallel channel array and which utilizes piezoelectric materials to construct the sidewalls of the ink-carrying channels may be seen by reference to U.S. Patent No. 4,536,097 to Nilsson. In Nilsson, an ink jet channel matrix is formed by a series of strips of a piezoelectric material disposed in spaced parallel relationships and covered on opposite sides by first and second plates. One plate is constructed of a conductive material and forms a shared electrode for all of the strips of piezoelectric material. On the other side of the strips, electrical contacts are used to electrically connect channel defining pairs of the strips of piezoelectric material. When a voltage is applied to the two strips of piezoelectric material which define a channel, the strips become narrower and higher such that the enclosed cross-sectional area of the channel is enlarged and ink is drawn into the channel. When the voltage is removed, the strips return to their original shape, thereby reducing channel volume and ejecting ink therefrom.

An ink jet printhead having a parallel ink-carrying channel array and which utilizes piezoelectric material to form a shear mode actuator for the vertical walls of the channel has

also been disclosed. For example, U.S. Patent Nos. 4,879,568 to Bartky et al. and 4,887,100 to Michaelis et al. each disclose an ink jet printhead channel array in which a piezoelectric material is used as the vertical wall along the entire length of each channel forming the
5 array. In these configurations, the vertical channel walls are constructed of two oppositely poled pieces of piezoelectric material mounted next to each other and sandwiched between top and bottom walls to form the ink channels. Once the ink channels are formed, electrodes are then deposited along the entire height of the vertical channel
10 wall. When an electric field normal to the poling direction of the pieces of piezoelectric material is generated between the electrodes, the vertical channel wall distorts to compress the ink jet channel in a shear mode fashion.

SUMMARY OF THE INVENTION

15 The invention discloses an ink jet printhead, comprising:
a base section formed from a piezoelectric material, said base section having a plurality of generally parallel spaced projections extending longitudinally along said base section, each of said projections having a top side;
20 a plurality of intermediate sections, each said intermediate section having a top side and a bottom side and a conductive mounting for mounting said plurality of intermediate sections on said top side of a corresponding one of said plurality of base section projections, each of said intermediate sections formed from a piezoelectric
25 material; and
a top section having a conductive mounting for mounting said top section to said top side of each of said plurality of intermediate sections;
wherein said base section, said plurality of intermediate
30 sections and said top section define a plurality of generally parallel, axially extending ink-carrying channels from which ink may be ejected therefrom.



The invention further discloses an ink jet printhead comprising:
a generally U-shaped actuator having first and second top walls;
a first side actuator having a bottom wall conductively mounted
to said first top wall of said generally U-shaped actuator and a top
5 wall;

a second side actuator having a bottom wall conductively mounted
to said second top wall of said generally U-shaped actuator and a top
wall; and

a top section having a bottom wall conductively mounted to said
10 top walls of said first and second side actuators;

wherein said generally U-shaped actuator, said first side
actuator, said second side actuator and said top section define an
elongated liquid confining channel.

The invention yet further discloses an ink jet printhead
15 comprising:

a base comprising:

a plurality of generally U-shaped actuators having first and
second top walls;

a plurality of first side actuators, each said first side
20 actuator having a bottom wall conductively mounted to said first top
wall of one of said generally U-shaped actuators and a top wall;

a plurality of second side actuators, each said second side
actuator having a bottom wall conductively mounted to said second top
wall of one of said generally U-shaped actuators and a top wall; and

25 a top section having a bottom wall conductively mounted to said
top walls of said first and second side actuators;

wherein said generally U-shaped actuators, first side actuators,
second side actuators and top section define said elongated liquid
confining channels, i.e. it continues directly on said channels

30 terminating at said front side of said base;

a cover having a corresponding number of apertures formed therein mounted to said front side of said base, said apertures positioned on said cover to define first, second, and third generally parallel aperture rows of at least one aperture each, each one of said apertures
5 in communication with a corresponding one of said channels; and

means for simultaneously actuating said channels in communication with said apertures positioned in said first, second or third row, respectively.

BRIEF DESCRIPTION OF THE DRAWING

10 Embodiments of the invention will now be described with reference to the accompanying drawings, in which:

FIG. 1 is a schematic illustration of a continuous jet type ink jet printhead;

15 FIG. 2 is a schematic illustration of a drop on demand type ink jet printhead.

FIG. 3 is a perspective view of a schematically illustrated ink jet printhead constructed in accordance with the teachings of the present invention;

20 FIG. 4 is an enlarged partial cross-sectional view of the ink jet printhead of FIG. 3 taken along lines 4--4 and illustrating a parallel channel array of the ink jet printhead of FIG. 3;

FIG. 5 is a side elevational view of the ink jet printhead of FIG. 3;

25 FIG. 6a is an enlarged partial cross-sectional view of a rear portion of the ink jet printhead of FIG. 4 taken along lines 6a--6a;

FIG. 6b is an enlarged partial cross-sectional view of a rear portion of the ink jet printhead of FIG. 4 taken along lines 6b--6b;

30 FIG. 7 is an enlarged partial perspective view of the rear portion of the ink jet printhead of FIG. 3 with top body portion removed;

FIG. 8a is a front elevational view of a single, undeflected, actuator sidewall of the ink jet printhead of FIG. 3;

FIG. 8b is a front elevational view of the single actuator sidewall of FIG. 8a after deflection;

5 FIG. 9a is a front view of an alternate embodiment of the schematically illustrated ink jet printhead of FIG. 3 with front wall removed and after deflection of the actuator sidewalls of the parallel channel array;

10 FIG. 9b is an enlarged partial front view of the schematically illustrated ink jet printhead of FIG. 9a;

FIG. 9c is a graphically illustrated electrostatic field displacement analysis for the sidewall configuration of FIG. 9b;

15 FIG. 10a is a front elevational view of a second embodiment of the undeflected actuator sidewall illustrated in FIG. 8a; FIG. 10b is a front elevational view of the actuator sidewall of FIG. 10a after deflection;

20 FIG. 11a is a front elevational view of a third embodiment of the undeflected actuator sidewall illustrated in FIG. 8a;

FIG. 11b is a front elevational view of the actuator wall of FIG. 11a after deflection;

25 FIG. 12a is a front elevational view of a fourth embodiment of the undeflected actuator sidewall illustrated in FIG. 9a;

FIG. 12b is a front elevational view of the actuator wall of FIG. 12a after deflection;

30 FIG. 13a is a front elevational view of a fifth embodiment of the undeflected actuator wall illustrated in FIG. 8c;

FIG. 13b is a front elevational view of the actuator wall of FIG. 13c after deflection; and

35 FIG. 14 is a partial cross-sectional view of

another alternate embodiment of the ink jet printhead of FIG. 3 taken along lines 14--14;

5 FIG. 15a is an enlarged partial front view of yet another alternate embodiment of the ink jet printhead of FIG. 3;

10 FIG. 15b is a second front view of the ink jet printhead of FIG. 15a with front wall removed and after a first deflection of a deflection sequence for the actuator sidewalls of the parallel channel array;

FIG. 15c is the ink jet printhead of FIG. 16b after a second deflection of the deflection sequence; and

15 FIG. 15d is the ink jet printhead of FIG. 15b after a third deflection of the deflection sequence.

DETAILED DESCRIPTION OF A PREFERRED EMBODIMENT

20 While the numbering of elements in the following detailed description may appear to be in a somewhat unusual sequence, the sequence has been selected to provide, wherever possible, commonality in numbering between this application and the co-pending applications previously incorporated by reference.

25 Referring now to the drawing wherein thicknesses and other dimensions have been exaggerated in the various figures as deemed necessary for explanatory purposes and wherein like reference numerals designate the same or similar elements throughout the several views, in FIG. 3, 30 an ink jet printhead 10 constructed in accordance with the teachings of the present invention may now be seen. The ink jet printhead 10 includes a main body portion 12 which is aligned, mated and bonded to an intermediate body portion 14 which, in turn, 35

is aligned, mated and bonded to a top body portion 16. As will be better seen in FIG. 6a, in the embodiment of the invention illustrated herein, the main body portion 12 continues to extend rearwardly past the intermediate body portion 14 and the top body portion 16, thereby providing a surface on the ink jet printhead 10 on which a controller (not visible in FIG. 3) for the ink jet printhead 10 may be mounted. It is fully contemplated, however, that the main body portion 12, the intermediate body portion 14 and the top body portion 16 may all be of the same length, thereby requiring that the controller 50 be remotely positioned with respect to the ink jet printhead 10.

A plurality of vertical grooves of predetermined width and depth are formed through the intermediate body portion 14 and the main body portion 12 to form a plurality of pressure chambers or channels 18 (not visible in FIG. 3), thereby providing a channel array for the ink jet printhead 10. A manifold 22 (also not visible in FIG. 3) in communication with the channels 18 is formed near the rear portion of the ink jet printhead 10. Preferably, the manifold 22 is comprised of a channel extending through the intermediate body portion 14 and the top body portion 16 in a direction generally perpendicular to the channels 18. As to be more fully described below, the manifold 22 communicates with an external ink conduit 46 to provide means for supplying ink to the channels 18 from a source of ink 25 connected to the external ink conduit 46.

Continuing to refer to FIG. 3, the ink jet printhead 10 further includes a front wall 20 having a front side 20a, a back side 20b and a

5 plurality of tapered orifices 26 extending
therethrough. The back side 20b of the front wall
20 is aligned, mated and bonded with the main,
intermediate and top body portions 12, 14 and 16,
respectively, such that each orifice 26 is in
communication with a corresponding one of the
plurality of channels 18 formed in the intermediate
body portion 14, thereby providing ink ejection
nozzles for the channels 18. Preferably, each
10 orifice 26 should be positioned such that it is
located at the center of the end of the
corresponding channel 18, thereby providing ink
ejection nozzles for the channels 18. It is
contemplated, however, that the ends of each of the
15 channels 18 could function as orifices for the
ejection of drops of ink in the printing process
without the necessity of providing the front wall
20 and the orifice 26. It is further contemplated
that the dimensions of the orifice array 27
20 comprised of the orifices 26 could be varied to
cover various selected lengths along the front wall
20 depending on the channel requirements of the
particular ink jet printhead 10 envisioned. For
example, in one configuration, it is contemplated
25 that the orifice array 27 would be approximately
0.064 inches in height and approximately 0.193
inches in length and be comprised of about twenty-
eight orifices 26 provided in a staggered
configuration where the centers of adjacent
30 orifices 26 would be approximately 0.0068 inches
apart.

Referring next to FIG. 4, an enlarged partial
cross-sectional view of the ink jet printhead 10
taken along lines 4--4 of FIG. 3 may now be seen.
35 As may now be clearly seen, the ink jet printhead

5 10 includes a plurality of parallel spaced channels 18, each channel 18 vertically extending from the top body portion 16, along the intermediate body portion 14 and part of the main body portion 12 and extending lengthwise through the ink jet printhead 10. The main body portion 12 and the top body portion 16 are constructed of an inactive material, for example, unpolarized piezoelectric material. Separating adjacent channels 18 are sidewall actuators 28, each of which include a first sidewall section 30 and a second sidewall section 32. The first sidewall section 30 is constructed of an inactive material, for example unpolarized piezoelectric material, and, in the preferred embodiment of the invention, is integrally formed with the body portion 12. The second sidewall section 32, is formed of a piezoelectric material, for example, lead zirconate titante (or "PZT"), polarized in direction "P" perpendicular to the channels 18.

15 20 Mounted to the top side of each first sidewall section 30 is a metallized conductive surface 34, for example, a strip of metal. Similarly, metallized conductive surfaces 36 and 38, also formed of a strip of metal, are mounted to the top and bottom sides, respectively, of each second sidewall section 32. A first layer of a conductive adhesive 40, for example, an epoxy material, is provided to conductively attach the metallized conductive surface 34 mounted to the first sidewall section 30 and the metallized conductive surface 38 mounted to the second sidewall section 32. Finally, the bottom side of the top body portion 16 is provided with a metallized conductive surface 42 which, in turn, is conductively mounted to the

5 metallized conductive surfaces 36 of the second
sidewall section 32 by a second layer of a
conductive adhesive 44. In this manner, a series
of channels 18, each channel being defined by the
unpolarized piezoelectric material of the main body
portion 12 along its bottom, the layer of
conductive adhesive 44 along its top and a pair of
sidewall actuators 28 have been provided. Each
sidewall actuator 28 is shared between adjacent
10 channels 18. The first sidewall section 30 may be
formed having any number of various heights
relative to the second sidewall section 32. It has
been discovered, however, that a ratio of 1.3 to 1
between the first sidewall section 30 constructed
15 of unpolled piezoelectric material and the second
sidewall section 32 formed of polarized
piezoelectric material has proven quite
satisfactory in use. Furthermore, while the
embodiment of the invention illustrated in FIG. 4
20 includes the use of metallized conductive surfaces
34, 36, 38 and 42, it has been discovered that the
use of such surfaces may be omitted without
adversely affecting the practice of the invention.

Referring next to FIG. 5, a side elevational
25 view of the high density ink jet printhead 10 which
better illustrates the means for supplying ink to
the channels 18 from a source of ink 25 may now be
seen. Ink stored in the ink supply 25 is supplied
via the external ink conduit 46 to an internal ink
conduit 24 which extends vertically through the top
30 body portion 16. The internal ink conduit 24 may
be positioned anywhere in the top body portion 16
of the ink jet printhead 10 although, in the
preferred embodiment of the invention, the internal
35 ink conduit 24 extends through the general center

of the top body portion 16. Ink supplied through the internal ink conduit 24 is transmitted to a manifold 22 extending generally perpendicular to and in communication with each of the channels 18. The manifold 22 may be formed within the intermediate body portion 14 or the top body portion 16, although, in the printhead illustrated herein, the manifold 22 is formed within the top body portion 16. While the channels 18 extend across the entire length of the ink jet printhead 10, a block 48 of a composite material blocks the back end of the channels 18 so that ink supplied to the channels 18 shall, upon actuation of the channel 18, be propagated in the forward direction where it exits the ink jet printhead 10 through the corresponding one of the tapered orifices 26.

Referring next to FIG. 6a, a cross-sectional view of a rear portion of the ink jet printhead 10 taken along lines 6a--6a of FIG. 3 which illustrates a sidewall of the channel 18 may now be seen. Also visible here is the electrical connection of the ink jet printhead 10. A controller 50, for example, a microprocessor or other integrated circuit, is electrically connected to the metallized conductive surface 34 which separates the first and second sidewall actuator sections 30, 32. It should be further noted that while, in the embodiment illustrated in FIG. 6a, a remotely located controller is disclosed, it is contemplated that the controller may be mounted on the rearwardly extending portion 12' of the main body portion 12. Each metallized conductive surface 42 which separates the second sidewall section 32 and the top body portion 16, on the other hand, is connected to ground. While FIG. 6a

illustrates the electrical connection of a single
conductive strip 34 to the controller 50 and the
single conductive strip 42 to ground, it should be
clearly understood that each sidewall actuator 30
5 has a similarly constructed conductive strip 34
extending outwardly at the rear portion of the ink
jet printhead 10 for connection to the controller
50 and a similarly constructed conductive strip 42
connected to ground. As to be more fully described
10 below, the controller 50 operates the ink jet
printhead 10 by transmitting a series of positive
and/or negative charges to selected ones the
conductive strips 34. As the top body portion 16
and main body portion 12 are non-conductive and
15 layer of adhesive material 40, conductive
metallized surface 38, intermediate body portion
14, conductive metallized surface 36, layer of
adhesive material 44 and conductive metallized
surface 42 are all conductive, a voltage drop
20 across the intermediate body portions 14
corresponding to the selected metallized conductive
surfaces 34 will be produced. This will cause the
sidewalls which includes the intermediate body
portion 14 across which a voltage drop has been
25 placed to deform in a certain direction. Thus, by
selectively placing selected voltages on the
various sidewall actuators, the channels 18 may be
selectively "fired", i.e., caused to eject ink, in
a given pattern, thereby producing a desired image.

30 The exact configuration of a pulse sequence
for selectively firing the channels 18 may be
varied without departing from the teachings of the
present invention. For example, a suitable pulse
sequence may be seen by reference to the article to
35 Wallace, David B., entitled "A Method of

Characteristic Model of a Drop-on-Demand Ink-Jet Device Using an Integral Method Drop Formation Model", 89-WA/FE-4 (1989). In its most general sense, the pulse sequence for a sidewall actuator 28 consists of a positive (or "+") segment which imparts a pressure pulse into the channel 18 being fired by that sidewall actuator 28 and a negative (or "-") segment which imparts a complementary, additive pressure pulse into the channel 18 adjacent to the channel 18 being fired which shares the common sidewall 28 being actuated. For example, in one embodiment of the invention, each sidewall actuator 28 of the pair of adjacent sidewall actuators 28 which define a channel 18 has a pulse sequence which includes the aforementioned positive and negative voltage segments, but for which the positive and negative voltage segments are applied during opposing time intervals for respective ones of the pair, thereby forming a +, -, +, - voltage pattern which would cause every other channel 18 to eject a droplet of ink after the application of voltage. In a second embodiment of the invention, a first pair of adjacent sidewall actuators 28 which define a first channel may have a pulse sequence which includes the aforementioned positive and negative voltage segments applied during opposing time intervals for respective ones of the first pair, and a second pair of adjacent sidewall actuators 28 which define a second channel adjacent to the first channel may have no voltage applied thereto during these time intervals, thereby forming a +, -, 0, 0 voltage pattern in which every fourth channel 18 would fire after the application of voltage. As may be further seen, multiple patterns of channel actuations too

numerous to mention may be provided by the selective application of voltages to the first layer of conductive adhesive 40 corresponding to each sidewall actuator 28.

5 Referring next to FIG. 6b, a cross-sectional view of the rear portion of the ink jet printhead 10 taken along lines 6b--6b which better illustrates the ink supply path to the channel 18 via the internal ink conduit and the manifold 22. Also more clearly visible in FIG. 6b is the block 48, typically formed of an insulative composite material, which blocks the back end of the channel 18 so that ink supplied to the channel 18 will be propagated forward upon the activation of a pressure pulse in a manner more fully described elsewhere.

20 Referring next to FIG. 7, the rear portion of the ink jet printhead with the top body portion 16 and the block of composite material 48 removed is now illustrated to more clearly show the details of the structure of the high density ink jet printhead 10. As may be seen herein, in the forming of channels 18, preferably by sawing the main body portion 12 and attached intermediate body portion 14 in predetermined locations, portions of the metallized conductive surfaces 34 are removed, thereby permitting the metallized conductive surfaces 34 to function as individual electrical contact for each sidewall 30 and portions of metallized conductive surfaces 36 are permitted to function as individual ground connections for each sidewall 30.

30 Referring next to FIG. 8a, a single actuator wall of the ink jet printhead 10 may now be seen. The sidewall actuator 28 is comprised of a first

5 actuator sidewall section 30 and a second actuator
sidewall section 32, both of which extend along the
entire length of an adjacent channel 18. The first
sidewall section 30 is formed of unpolarized
piezoelectric material integrally formed with the
10 main body portion 12 of the ink jet printhead 10.
The second sidewall section 32 is formed of a
piezoelectric material poled in a direction
perpendicular to the adjacent channel 18 and is
conductively mounted to the top body portion 16 of
the high-density ink jet printhead 10 which, as
15 previously set forth, is also formed of an
unpolarized piezoelectric material. The first and
second actuator sidewall sections 30, 32 are
conductively mounted to each other. For example,
the first and second sidewall sections 30, 32 may
be provided with a layer of conductive material 34,
38, respectively, bonded together by a layer of a
20 conductive adhesive 40. Finally, the top side of
the second actuator sidewall 32 is conductively
mounted to the top body portion 16. by
conductively mounting the metallized conductive
surfaces 36, 42.

25 Referring next to FIG. 8b, the deformation of
the actuator wall illustrated in FIG. 8a when an
electric field is applied between the metallized
conductive surfaces 34 and 42, shall now be
described in detail. When a selected voltage is
supplied to the metallized conductive surface 34,
30 an electric field normal to the direction of
polarization is produced. The second sidewall
section 32 will then attempt to undergo shear
deformation. However, as the metallized conductive
surface 36 of the second sidewall section 32 is
35 restrained, the metallized conductive surface 38

will move in a shear motion while the metallized
conductive surface 36 remains fixed. The first
sidewall section 30, being formed of an inactive
material, is unaffected by the electric field.
5 However, since the first sidewall section 30 is
mounted to the second sidewall section 32
undergoing shear deformation, the first sidewall
section 30 will be pulled by the second sidewall
section 32, thereby forcing the first sidewall
10 section 30 to bend in what is hereby defined as a
"shear-like motion". This motion by the sidewall
28 produces a pressure pulse which increases the
pressure in one of the adjacent channels 18
partially defined thereby to cause the ejection of
15 a droplet of ink from that channel 18 shortly
thereafter and a reinforcing pressure pulse in the
other one of the adjacent channels 18.

Referring next to FIG. 9a, the typical
operation of an alternate embodiment of the channel
array of the high density ink jet printhead 10
subject of the present application will now be
described. In this embodiment of the invention,
20 the metallized conductive surfaces 34 and 38 and
the layer of conductive adhesive 40 have been
replaced by a single layer of conductive adhesive
51. Similarly, the metallized conductive surfaces
36 and 42 and the layer of conductive adhesive 44
25 have been replaced by a single layer of conductive
adhesive 52. However, in order to eliminate the
aforementioned metallized conductive surfaces while
30 maintaining satisfactory operation of the high
density ink jet printhead 10, a surface 14b of the
intermediate body portion 14 and a surface 12a of
the main body portion 12 must be conductively
35 mounted together in a manner such that a voltage

5 may be readily applied to the single layer of
conductive adhesive 51 and a surface 14a of the
intermediate body portion 14 and a surface 16a of
the top body portion 16 must be conductively
mounted together in a manner such that the single
layer of conductive adhesive 52 therebetween may be
readily connected to ground.

10 To activate the ink jet printhead 10, the
controller 51 (not shown in FIG. 9a) responds to an
input image signal representative of the image
desired to be printed and applies voltages of
predetermined magnitude and polarity to selected
layers of conductive adhesive 51 which correspond
15 to certain ones of the actuator sidewalls 28 on
each side of the channels 18 to be activated. For
example, if a positive voltage is applied to a
layer of conductive adhesive 51, then an electric
field E perpendicular to the direction of
polarization is established in the direction from
20 the layer of conductive adhesive 51 towards the
layer of conductive adhesive 52 and the second
sidewall section 32 will distort in a shear motion
in a first direction normal to the channel 18 while
carrying the first sidewall section 30, thereby
25 cause the sidewall to undergo a shear-like
distortion. On the other hand, by applying a
negative voltage at the contact 34, the direction
of the electric field E is reversed and the second
sidewall section 32 will deflect in a shear motion
30 in a second direction, opposite to the first
direction, and normal to the channel 18. Thus, by
placing equal charges of opposite polarity on
adjacent sidewalls which define a channel 18
therebetween, a positive pressure wave is created
35 in the channel 18 between the two adjacent

sidewalls and a drop of ink is expelled, either through the open end 28 of the pressure chamber 18 or through the tapered orifice 26.

5 Referring next to FIG. 9b, an enlarged view of a pair of sidewall actuators 28 and a single channel 18 of the channel array of FIG. 9a in an unactivated mode may now be seen. As the sidewall actuators 28 illustrated here are identical in construction to those described with respect to
10 FIG. 9a, further description is not necessary. Prior to activation of the sidewall actuators 28, the channels 18 were filled with a nonconductive ink. The piezoelectric material used to form the sidewall actuators had a relative permittivity of
15 3300 and the nonconductive ink a relative permittivity of 1. Two separate tests were conducted using this embodiment of the invention, the first test having every fourth channel 18 activated by applying a voltage pattern of (plus, minus, zero, zero,...) and the second test having
20 every other channel 18 activated by applying a voltage pattern of (plus, minus, plus, minus....). As no significant differences were produced between the two tests, only the results of the second test is described below. In this test, the layer of
25 conductive material 52 was held at zero volts, the layer of conductive material 51a was held at plus 1.0 volts, and the layer of conductive material 51b was held at minus 1.0 volts. Such a voltage configuration would cause the center channel 18' to
30 compress.

Referring next to FIG. 9c, a graphical analysis of the electrostatic field generated during activation of the sidewall actuators 28 in
35 accordance with the parameters of the second test

5 may now be seen. As may be seen here, the displacement in the polarized piezoelectric material was of a magnitude such that tooth-to-tooth and jet-to-jet cross talk effects are negligible for nonconductive inks. One unexpected result was that the magnitude electric field in the unpolarized piezoelectric material was over sixty percent of that of the poled piezoelectric material. This phenomena occurred because the flow
10 of charge is dominated by the high permittivity of the piezoelectric material. In addition, the direction of the field in the unpolarized piezoelectric material is such that, if this material were polarized, the displacement of the tooth would increase by greater than sixty percent due to the unpolarized section of the tooth being longer than the polarized section. Thus, if the longer, piezoelectric material piece were polarized, the displacement would be still greater.

15
20 Although not illustrated herein, similar tests were performed using a conductive inks. In such a test, the conductive ink would short the layers of conductive material 51, 52 unless the sidewall actuators 28 are insulated by a thin layer of conductive material along the surface of the
25 sidewall actuators adjacent the channels filled with conductive ink. It is contemplated, therefore, that the interior of the channel be coated with a layer of dielectric material having a generally uniform thickness of between approximately 2 and 10 micrometers when the use of a conductive ink is contemplated. Apart from the requirement of a layer of dielectric material, the operation of the ink jet printhead 10 did not
30 differ significantly when a conductive ink was
35

utilized.

Referring next to FIG. 10a, a second embodiment of the sidewall actuator 28 may now be seen. This embodiment is comprised of a first sidewall section 30 formed of unpolarized piezoelectric material and integrally formed with and extending from the main body portion 12, a second sidewall section 54 formed of a piezoelectric material and a third sidewall section 56 also constructed of a piezoelectric material. The second and third sidewall sections 54, 56 should be bonded together such that the poling directions are rotated 180 degrees from each other. Each poled piezoelectric material sidewall section 54, 56 should have top and bottom metal layers of metallized material 57 and 58, 60 and 62, respectively. The first metallized conductive surface 57 of the second sidewall section 54 is mounted to the metallized conductive surface 34 of the first sidewall section 30 by the first layer of conductive adhesive 40 and the second metallized conductive surface 58 of the second sidewall section 54 is mounted to the first metallized conductive surface 60 of the third sidewall section 56 by a third layer of conductive adhesive 64. Finally, the second metallized conductive surface 62 of the third sidewall section 56 is mounted to the top body portion 16 by the second layer of conductive adhesive 44. Conductive surface 58 and conductive surface 38 should be interconnected and held at common potential, common i.e., ground. An electric field is created by applying a voltage to the conductive surface between the second and third sidewall sections 54, 56. As may be seen in FIG. 10b, the deformation of the sidewall actuator does

not differ significantly from that previously described except that each section 54, 56 undergo individual shear deformations.

5 Referring next to FIG. 11a, the third embodiment of the sidewall actuator 28 shall now be described in greater detail. More specifically, in this embodiment, the first and second sidewall sections are both constructed of poled piezoelectric materials such that the direction of
10 poling are aligned. An electric field is created by applying a voltage to the surface between the two poled piezoelectric material sections 30, 32. The electric field vector for the top sidewall section 32 is 180 degrees relative to that of the
15 first sidewall section 30. Accordingly, the top and bottom sidewall sections shear in opposite directions. However, less than half the voltage should be needed to achieve the same displacement. Here, the sidewall actuator is again comprised of
20 a pair of sidewall sections, but here, the first and second sidewall sections 66, 68, having first and second metallized conductive surfaces 70 and 72, 74 and 76, respectively, are both formed of an active material. Here, the first layer of
25 conductive adhesive 40 conductively mounts the first metallized conductive surface 34 of the main body portion 12 to the first metallized conductive surface 70 of the first sidewall section 66, a fourth layer of conductive adhesive 78 conductively
30 mounts the second metallized conductive surface 72 of the first sidewall section 66 and the first metallized conductive surface 74 of the second sidewall section 68, and the second layer of
35 conductive adhesive 44 conductively mounts the second metallized conductive surface 76 of the

second sidewall section 68 and the metallized
conductive surface 42 of the top body portion 16.
As illustrated in FIG. 11b, however, in this
embodiment of the invention, both sidewall sections
5 68, 70 undergo individual shear deformations.

Referring next to FIG. 12a, the fourth
embodiment of the sidewall actuator 28 shall now be
described in greater detail. Here, the sidewall
actuator 28 is comprised of a first sidewall
10 section 30 formed from an inactive material and
second, third, and fourth sidewall sections 80, 82
and 84 formed from an active material. Each active
sidewall section 80, 82 and 84 has first and second
metallized conductive surfaces 86 and 88, 90 and
15 92, and 94 and 96, respectively. In this
embodiment, the first layer of conductive adhesive
layer 40 conductively mounts the metallized
conductive surfaces 34 and 86, a third conductive
adhesive layer 98 conductively mounts metallized
20 conductive surfaces 88 and 90, a fourth conductive
adhesive layer 100 conductively mounts metallized
conductive surfaces 92 and 94, and the second
conductive adhesive layer 44 conductively mounts
metallized conductive surfaces 96 and 42. As may
25 be seen in FIG. 12b, the deformation is similar to
that illustrated and described with respect to FIG.
8b.

Referring next to FIG. 13a, the fifth
embodiment of the sidewall actuator 28 shall now be
described in greater detail. Here, the sidewall
actuator 28 is comprised of first, second, third,
30 fourth, fifth, and sixth sidewall sections 104,
106, 108, 110, 112, and 114, each formed of an
active material and each having first and second
metallized conductive surfaces 116 and 118, 120 and
35

124, 126 and 128, 130 and 132, 134 and 136, 138 and 140, respectively attached thereto. The first
conductive adhesive layer 40 conductively mounts
metallized conductive surfaces 34 and 116, a third
5 conductive adhesive layer 142 conductively mounts
metallized conductive surfaces layers 118 and 120,
a fourth conductive adhesive layer 144 conductively
mounts metallized conductive surfaces 124 and 126,
a fifth conductive adhesive layer 146 conductively
10 mounts metallized conductive surfaces 128 and 130,
a sixth conductive adhesive layer 148 conductively
mounts metallized conductive surfaces 132 and 134,
a seventh conductive adhesive layer 150
conductively mounts layers 136 and 138, and the
15 second conductive adhesive layer 44 conductively
mounts the metallized conductive surfaces 140 and
42. As may be seen in FIG. 13b, the deformation of
the sidewall actuator 28 set forth in this
embodiment of the invention is similar to that
20 described and illustrated in FIG. 11b.

Referring next to FIG. 14, yet another
embodiment of the invention may now be seen. In
this embodiment of the invention, the ink jet
printhead 410 is formed from an intermediate body
25 portion 414 constructed identically to the
intermediate body portion 14 mated and bonded to a
main body portion 412. As before, the intermediate
body portion 414 is constructed of piezoelectric
material polarized in direction P and has
30 metallized conductive surfaces 436, 438 provided on
surfaces 414b, 414a, respectively. In this
embodiment of the invention, however, the main body
portion 412 is also formed of a piezoelectric
material polarized in direction P and has a surface
35 412a upon which a layer of conductive material 434

is deposited thereon. The intermediate body portion 414 and the main body portion 412 are bonded together by a layer of conductive adhesive 440 which conductively mounts the metallized
5 conductive surface 434 of the main body portion 412 and the metallized conductive surface 438 of the intermediate body portion 414 together. Alternately, bonding between the metallized
10 conductive surface 434 of the main body portion 412 and the metallized conductive surface 438 of the intermediate body portion 414 may be achieved by soldering the metallized conductive surfaces 434,
15 438 to each other. It is further contemplated that, in accordance with one aspect of the invention, one or both of the metallized conductive surfaces 434 and/or 438 may be eliminated while maintaining satisfactory operation of the invention.

After the main body portion 412 and the
20 intermediate body portion 414 are conductively mounted together, a machining process is then utilized to form a channel array for the ink jet printhead 410. As may be seen in FIG. 14, a series
25 of axially extending, substantially parallel channels 418 are formed by machining grooves which extend through the intermediate body portion 414 and the main body portion 412. Preferably, the
30 machining process should be performed such that each channel 418 formed thereby should extend downwardly such that the metallized conductive surface 436, the intermediate body portion 414 of polarized piezoelectric material, the metallized
35 conductive surface 438, the layer of conductive adhesive 440, the metallized conductive surface 434 and a portion of the main body portion 412 of

polarized piezoelectric material are removed.

5 In this manner, the channels 418 which
comprise the channel array for the ink jet
printhead and sidewall actuators 428, each having
a first, sidewall actuator section 430 and a second
sidewall actuator section 432, which define the
sides of the channels 418 are formed. As to be
more fully described below, by forming the parallel
channel array in the manner herein described, a
10 generally U-shaped sidewall actuator 450
(illustrated in phantom in FIG. 14) which comprises
the first sidewall actuator sections 430 on
opposite sides of a channel 418 and a part of the
main body portion 412 which interconnects the first
sidewall actuator sections 430 on opposite sides of
15 the channel 418 is provided for each of the
channels 418.

Continuing to refer to FIG. 14, the channel
array for the ink jet printhead is formed by
20 conductively mounting a third block 416 of
unpolarized piezoelectric material, or other
inactive material, having a single layer of
metallized conductive surface 442 formed on the
bottom surface 416a thereof to the metallized
conductive surface 436 of the intermediate body
25 portion 414. The third block 416, which hereafter
shall be referred to as the top body portion 416 of
the ink jet printhead, may be constructed in a
manner similar to that previously described with
respect to the top body portion 16. To complete
30 assembly of the channel array for the ink jet
printhead, the metallized conductive surface 442 of
the top body portion 416 is conductively mounted to
the metallized conductive surface 436 of the second
sidewall section 432 by a second layer of
35

5 conductive adhesive 444. Preferably, the layer of
conductive adhesive 444 should be spread over the
metallized conductive surface 42 and the top body
portion 416 then be placed onto the metallized
conductive surface 436. As before, it is
contemplated that, in one embodiment of the
invention, either one or both of the metallized
conductive surfaces 436 or 442 may be eliminated
while maintaining satisfactory operation of the
10 high density ink jet printhead.

 To electrically connect the parallel channel
array illustrated in FIG. 14 such that a generally
U-shaped actuator 450 is provided for each of said
channels 418, a electrical contact 452, which, in
15 alternate embodiments of the invention may be the
metallized conductive surfaces 436 and 438
conductively mounted to each other by the
conductive adhesive 440, the metallized conductive
surfaces 436 and 438 soldered to each other, or a
20 single layer of conductive adhesive which attaches
surfaces 412a and 414a to each other, on one side
of the channel 418 is connected to +1 V. voltage
source (not shown). A second electrical contact
454 is then connected to a -1 V. voltage source.
25 To complete the electrical connections for the
parallel channel array, the layer of conductive
adhesive 444 is connected to ground. In this
manner, the channel 18 shall have a generally U-
shaped actuator 450 having a 2 V. voltage drop
30 between the contact 452 and the contact 454, a
first sidewall actuator having a +1 V. voltage drop
between the contact 452 and ground, and a second
sidewall actuator having a -1 V. voltage drop
between the contact 454 and ground. Once
35 constructed in this manner, when a +, -, +, -

5 voltage pattern is applied to the contacts 405 to cause every other channel 418 to eject a droplet of ink upon the application of voltage, significantly greater compressive and/or expansive forces on the channel 418 are produced by the combination U-shaped actuator 450 and the pair of sidewall actuators 432 that border the channel 418 than that exerted on the channel 18 by the sidewall actuators 28.

10 While the dimensions of a high density ink jet printhead having a parallel channel array with a U-shaped actuator for each channel may be readily varied without departing from the scope of the present invention, it is specifically contemplated that an ink jet printhead which embodies the present invention may be constructed to have the following dimensions:

15	Orifice Diameter:	40 um
	PZT length:	15 mm
20	PZT height:	120 um
	Channel height:	356 um
	Channel width:	91 um
	Sidewall width:	81 um

25 In the embodiments of the invention described above, each sidewall actuator 30 is shared between a pair of adjacent channels 18 and may be used, therefore, to cause the ejection of ink from either one of the channel pair. For example, in FIG. 9a, every other channel 18a is being fired by displacing both sidewall actuators 30 which form the sidewalls for the fired channels 18a such that those channels are compressed. The channels 18b adjacent to the fired channels 18a remain unfired. However, as each sidewall actuator 30 is shared between a fired channel 18a and an unfired channel

30

35

18b, the sidewall actuators 30 which form the sidewalls for the unfired channels 18b, are also displaced, although not in a manner which would cause the ejection of ink therefrom. The pressure pulse produced in the unfired channels 18b by the displacement of the sidewall actuators 30 necessary to actuate the fired channels 18a is commonly referred to as "cross-talk." Under certain conditions such as the use of low ink viscosity and low surface tension ink, the cross-talk produced by the sidewall actuators 30 in the unfired channels 18b located adjacent to the fired channels 18a may result in an unwanted actuation of the unfired channel 18b.

Referring next to FIG. 15a, a schematic illustration of an alternate embodiment of the front wall portion 20' of the ink jet printhead 10 of FIG. 3 which may be utilized to eliminate or reduce cross-talk produced during the operation of the ink jet printhead 10 of FIG. 9a shall now be described in greater detail. In this embodiment of the invention, an orifice array 27' is comprised of orifices 26-1, 26-2, 26-3, 26-4, 26-5, 26-6, 26-7 and 26-8 disposed in a slanted array configuration. More specifically, each of the orifices 26-1 through 26-8 extends through the cover 20' to communicate with a corresponding channel 18-1, 18-2, 18-3, 18-4, 18-5, 18-6, 18-7, 18-8, respectively, of the ink jet printhead 10 and are grouped together such that each orifice 26-1 through 26-8 in a particular group is positioned a distance "d", which, in one embodiment of the invention, is approximately equal to 1/3 pixel, in motion direction "A" from the adjacent orifice also included in that particular group. For example, in

the orifice array 27 illustrated in FIG. 15a, the orifices 26-1 and 26-2; 26-3, 26-4 and 26-5; and 26-6, 26-7 and 26-8 form first, second and third orifice groups, respectively. During the operation of the ink jet printhead 10 constructed in accordance with the present invention and having an orifice array such as that illustrated in FIG. 15a, orifices 26-1, 26-4 and 26-7, which are positioned in a first row, would be fired together, 26-2, 26-5 and 26-8, which are positioned in a second row, would be fired together, and 26-3, 26-6 and 26-9, which are positioned in a third row, would be fired together, by compressing the sidewall actuators 28 (not shown in FIG. 15) which define the sidewalls of the fired channels. By firing the orifices 26-1 through 26-8 in this manner, cross-talk effects are minimized. Specifically, at $t=1$ (see FIG. 15b), both sidewalls 28 which define the channels 18-3, 18-6 and 18-9 (which correspond to a first row of orifices 26-3, 26-6 and 26-9) are actuated simultaneously by placing a positive voltage drop across the second sidewall sections 32 in the manner previously described with respect to FIG. 9a. In response thereto, the channels 18-3, 18-6, 18-9 are compressed, thereby imparting a pressure pulse to the ink within the channels to cause the ejection of a drop of ink therefrom. The likelihood of unwanted actuation of adjacent channels 18-2, 18-4, 18-5, 18-7 and 18-8 is reduced as only one of the sidewalls 28 defining these channels have been activated, thereby reducing the magnitude of the pressure pulse imparted to the unactuated channels by one-half.

At $t=2$ (see FIG. 15c), the paper has travelled approximately $1/3$ pixel in the direction "A" and

the channels 18-1, 18-4 and 18-7 (which correspond to a second row of orifices 26-1, 26-4 and 26-7) located in the second row should now be activated in a similar manner. As before, the likelihood of unwanted actuation of the channels 18-2, 18-3, 18-5, 18-6 and 18-8 is reduced due to the reduction by one-half of the magnitude of the pressure pulse imparted to the unactuated channels. Finally, at $t=3$ (see FIG. 15d), the paper has travelled about another $1/3$ pixel in the direction "A" and the channels 18-2, 18-5 and 18-8 (which correspond to a third row of orifices 26-2, 26-5 and 26-8) located in the third row should now be activated, again in a similar manner. As before, the likelihood of unwanted actuation of the adjacent channels 18-1, 18-3, 18-4, 18-6, 18-7 and 18-9 is reduced in view of the reduction of the magnitude of the pressure pulse imparted to the unactuated channels.

Thus, there has been described and illustrated herein, a high density ink jet printhead having multiple ink-carrying channels extending therethrough and sidewall actuators constructed of an active material and shared between adjacent ones of the multiple channels. However, those skilled in the art will recognize that many modifications and variations besides those specifically mentioned may be made in the techniques described herein without departing substantially from the concept of the present invention. Accordingly, it should be clearly understood that the form of the invention as described herein is exemplary only and is not intended as a limitation on the scope of the invention.

The claims defining the invention are as follows:

1. An ink jet printhead, comprising:

a base section formed from a piezoelectric material, said base section having a plurality of generally parallel spaced projections extending longitudinally along said base section, each of said projections having a top side;

a plurality of intermediate sections, each said intermediate section having a top side and a bottom side and a conductive mounting for mounting said plurality of intermediate sections on said top side of a corresponding one of said plurality of base section projections, each of said intermediate sections formed from a piezoelectric material; and

a top section having a conductive mounting for mounting said top section to said top side of each of said plurality of intermediate sections;

wherein said base section, said plurality of intermediate sections and said top section define a plurality of generally parallel, axially extending ink-carrying channels from which ink may be ejected therefrom.

2. An ink jet printhead according to claim 1 wherein said base section projections and said intermediate sections define first and second sidewalls for each one of said plurality of ink-carrying channels and wherein said ink jet printhead further comprises means for imparting voltages of opposite polarity to said first and second sidewalls, respectively, defining each of said ink-carrying channels.

3. An ink jet printhead according to claim 2 wherein said means for imparting voltages of opposite polarity to said first and second sidewalls, respectively, further comprises:

means for selectively applying positive



voltage to said conductive mounting connecting said projection and said intermediate section of each of said plurality of first sidewalls; and

5

means for selectively applying a negative voltage to said conductive mounting connecting said projection and said intermediate section of each of said plurality of second sidewalls.

4. An ink jet printhead according to claim 3 and further comprising means for connecting said conductive mounting connecting said top cover and said plurality of intermediate sections to ground.

5. An ink jet printhead according to claim 4 wherein each of said plurality of intermediate sections are poled in a direction generally perpendicular to the direction of the axial extension of said plurality of parallel channels.

6. An ink jet printhead according to claim 5 wherein said base section is also poled in said direction generally perpendicular to the direction of the axial extension of said plurality of channels.

5

7. An ink jet printhead according to claim 6 wherein said means for selectively applying positive voltage and said means for selectively applying negative voltage generates an electric field across each of said plurality of intermediate sections in a direction perpendicular to said direction of poling and generates an electric field generally perpendicular to said direction of poling along a first portion of said base section and generally parallel to said direction of poling along a second portion of said base section.

10

8. An ink jet printhead comprising:
a generally U-shaped actuator having first and second top walls;

a first side actuator having a bottom wall conductively mounted to said first top wall of said generally U-shaped actuator and a top wall;

5 a second side actuator having a bottom wall conductively mounted to said second top wall of said generally U-shaped actuator and a top wall; and

10 a top section having a bottom wall conductively mounted to said top walls of said first and second side actuators;

wherein said generally U-shaped actuator, said first side actuator, said second side actuator and said top section define a elongated liquid confining channel.

9. An ink jet printhead according to claim 8 and further comprising means for electrically connecting said generally U-shaped actuator for the selective application of a first pressure pulse to said elongated liquid confining channel.

10. An ink jet printhead according to claim 9 and further comprising:

5 means for selectively applying a positive voltage to said conductive mounting connecting said first side actuator and said first top side of said generally U-shaped actuator; and

10 means for selectively applying a negative voltage to said conductive mounting connecting said second side actuator and said second top side of said generally U-shaped actuator.

11. An ink jet printhead according to claim 9 and further comprising means for electrically connecting said first side actuator for the selective application of a second pressure pulse to said elongated liquid confining channel.

12. An ink jet printhead according to claim 11 and further comprising means for electrically connecting said second side actuator for the selective application of a third pressure pulse to said elongated liquid confining channel.

13. An ink jet printhead according to claim 12 and further comprising:

means for selectively applying a positive voltage to said conductive mounting connecting said first side actuator and said first top side of said generally U-shaped actuator; and

means for selectively applying a negative voltage to said conductive mounting connecting said second side actuator and said second top side of said generally U-shaped actuator;

means for connecting said conductive mounting connecting said top side to said first and second side actuators to ground.

14. An ink jet printhead comprising:

a base comprising:

plurality of generally U-shaped actuators having first and second top walls;

a plurality of first side actuators, each said first side actuator having a bottom wall conductively mounted to said first top wall of one of said generally U-shaped actuators and a top wall;

a plurality of second side actuators, each said second side actuator having a bottom wall conductively mounted to said second top wall of one of said generally U-shaped actuators and a top wall; and

a top section having a bottom wall conductively mounted to said top walls of said first and second side actuators;

wherein said generally U-shaped actuators, first side actuators, second side actuators and top section define said elongated liquid confining channels, said channels terminating at said front side of said base;

a cover having a corresponding number of apertures formed therein mounted to said front side of said base, said apertures positioned on said cover to define first, second, and third generally parallel aperture rows of at least one aperture each, each one of said apertures in communication with a corresponding one of said channels; and



means for simultaneously actuating said channels in communication with said apertures positioned in said first, second or third row, respectively.

15. An ink jet printhead according to claim 14 wherein said apertures are positioned in groups of up to three apertures per group, each said aperture in a group vertically separated from the remaining apertures in said group and separated from adjacent apertures in said group by a selected distance.

16. An ink jet printhead according to claim 15 wherein said selected distance is about 1/3 pixel.

DATED this THIRTIETH day of NOVEMBER 1993

Compaq Computer Corporation

Patent Attorneys for the Applicant
SPRUSON & FERGUSON

High Density Ink Jet Printhead

Abstract of the Disclosure

An ink jet printhead for a drop-on-demand type ink jet printing system is disclosed. The printhead includes a base section (12) having a series of generally parallel spaced projections (30) extending longitudinally therealong, a series of intermediate sections (14) conductively mounted on a top side of a corresponding one of the series of base section projections (30) and a top section (16) conductively mounted to a top side of each of the series of intermediate sections (14).

(Figure 4)



21025/92

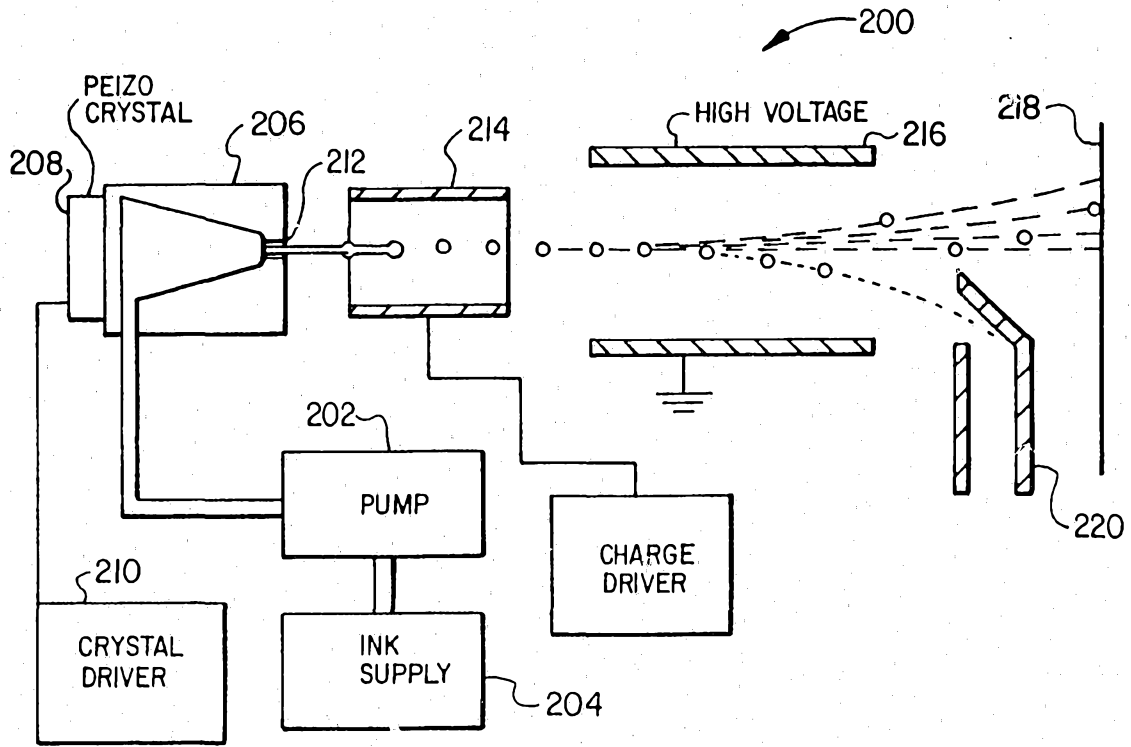

FIG. 1

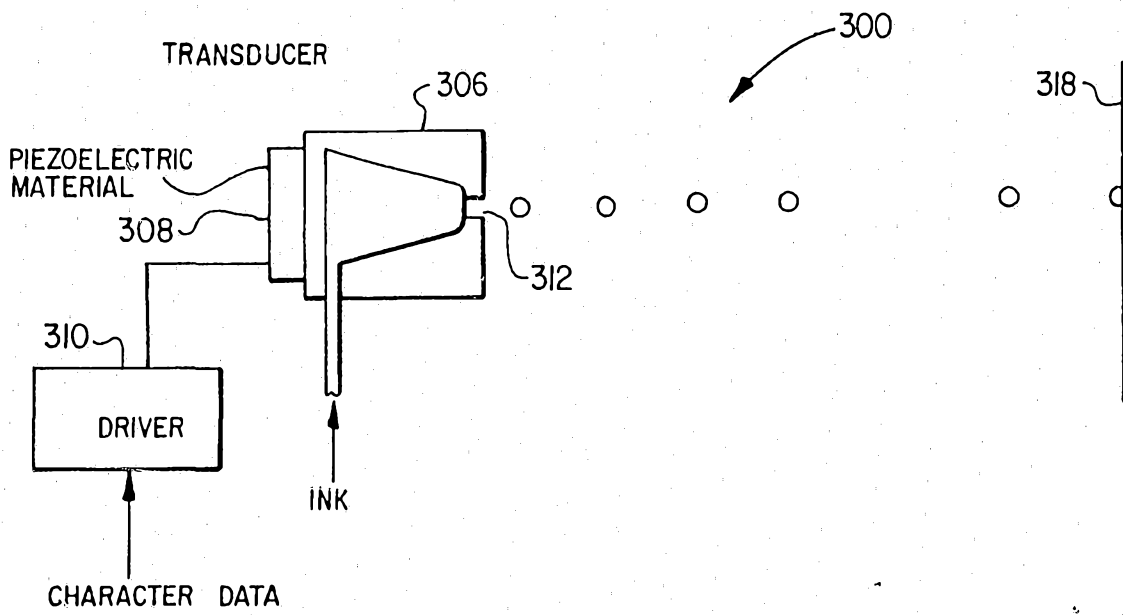
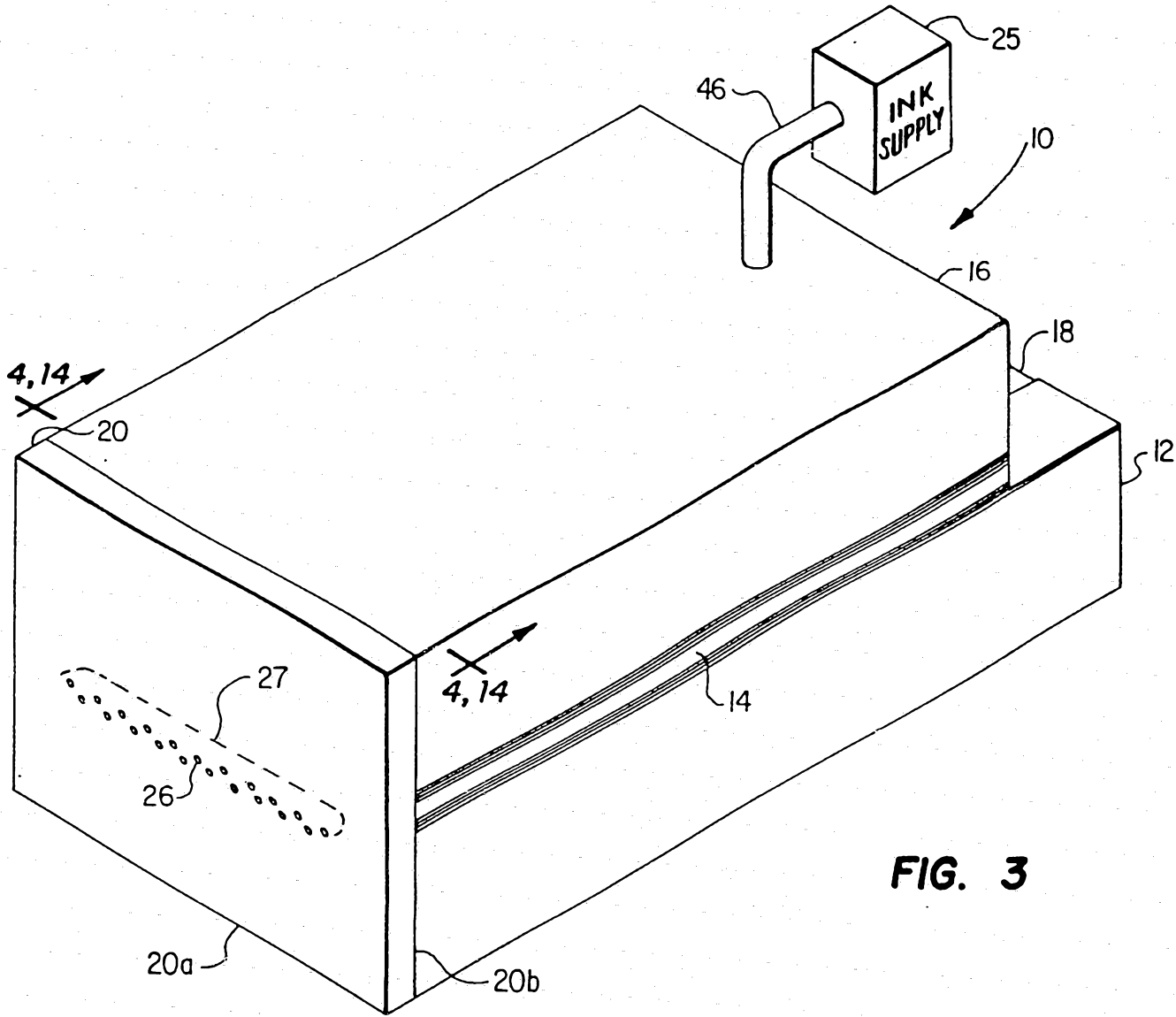

FIG. 2



21025/92

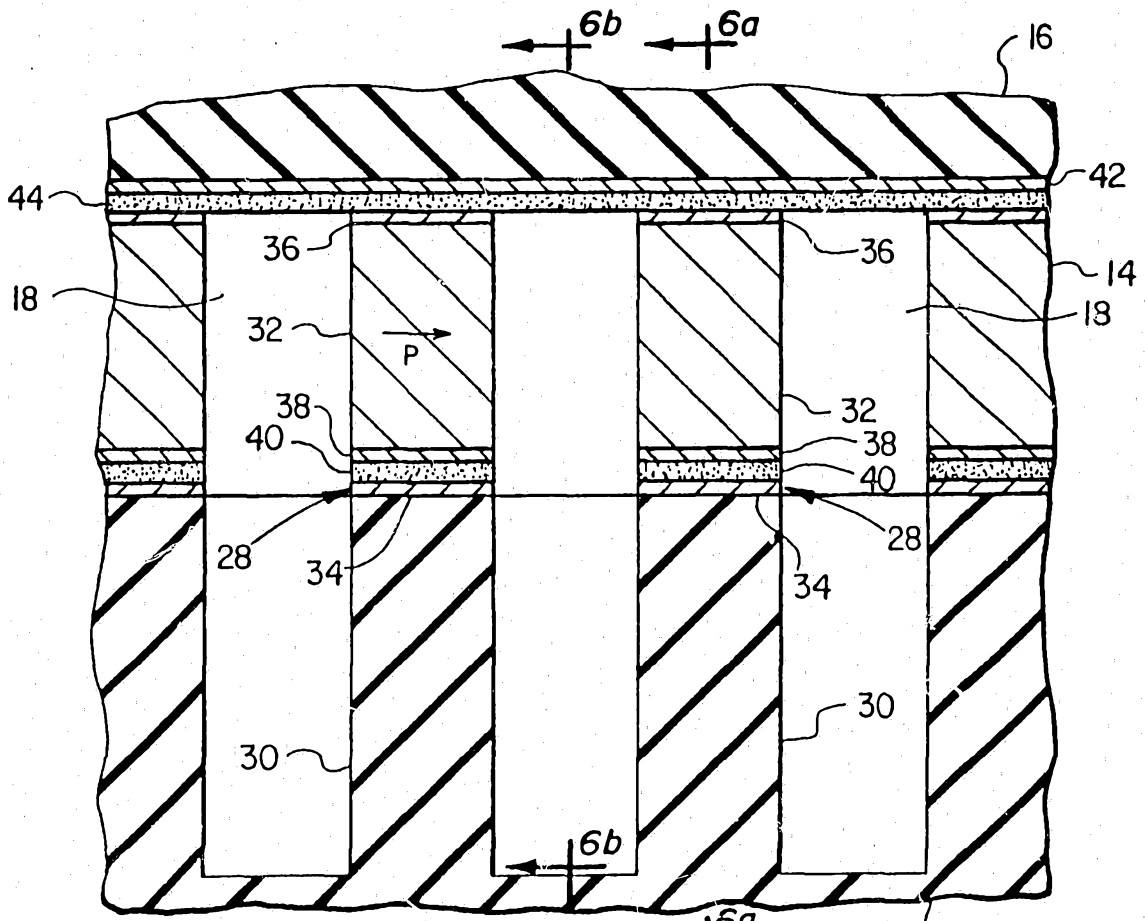

FIG. 4

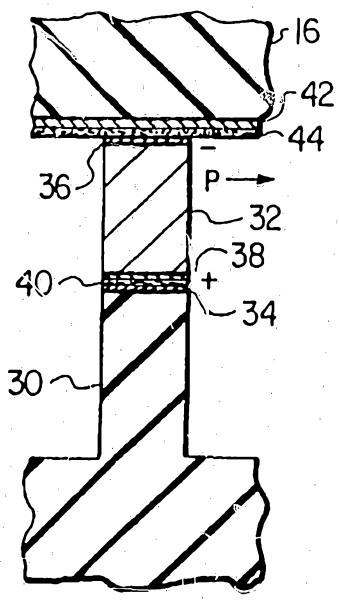

FIG. 8A

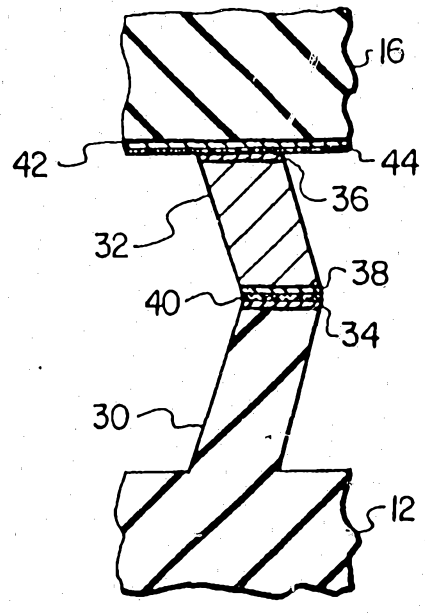

FIG. 8B

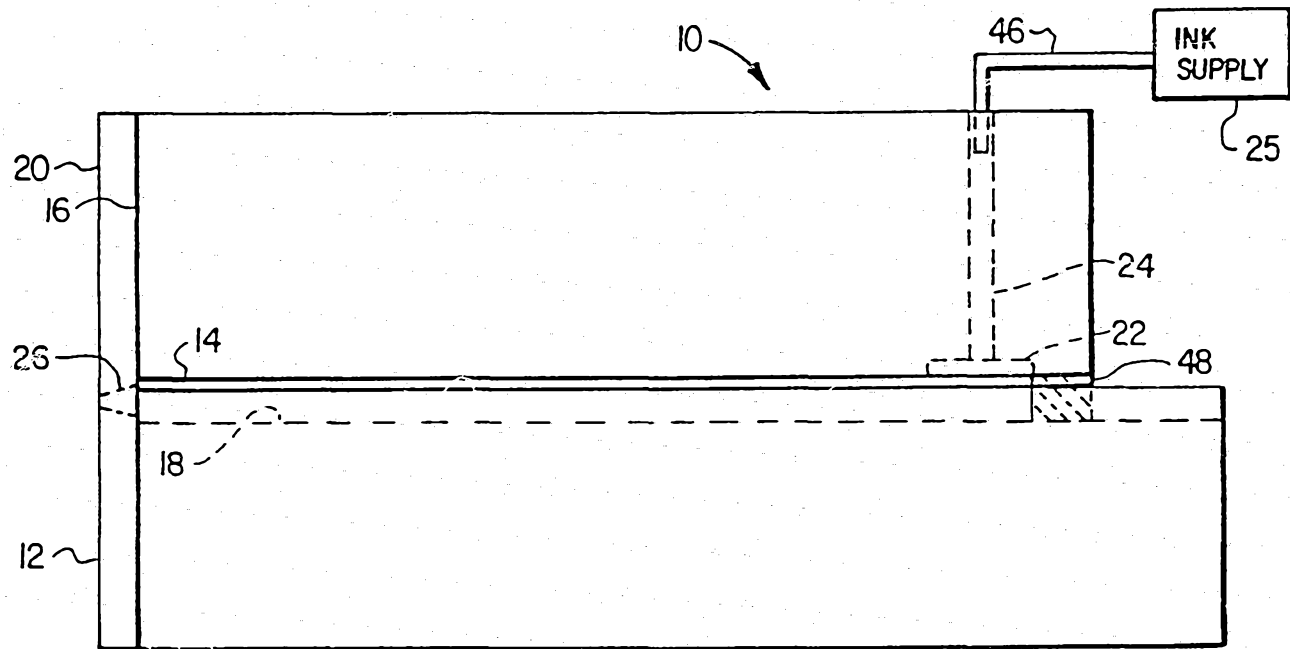

FIG. 5

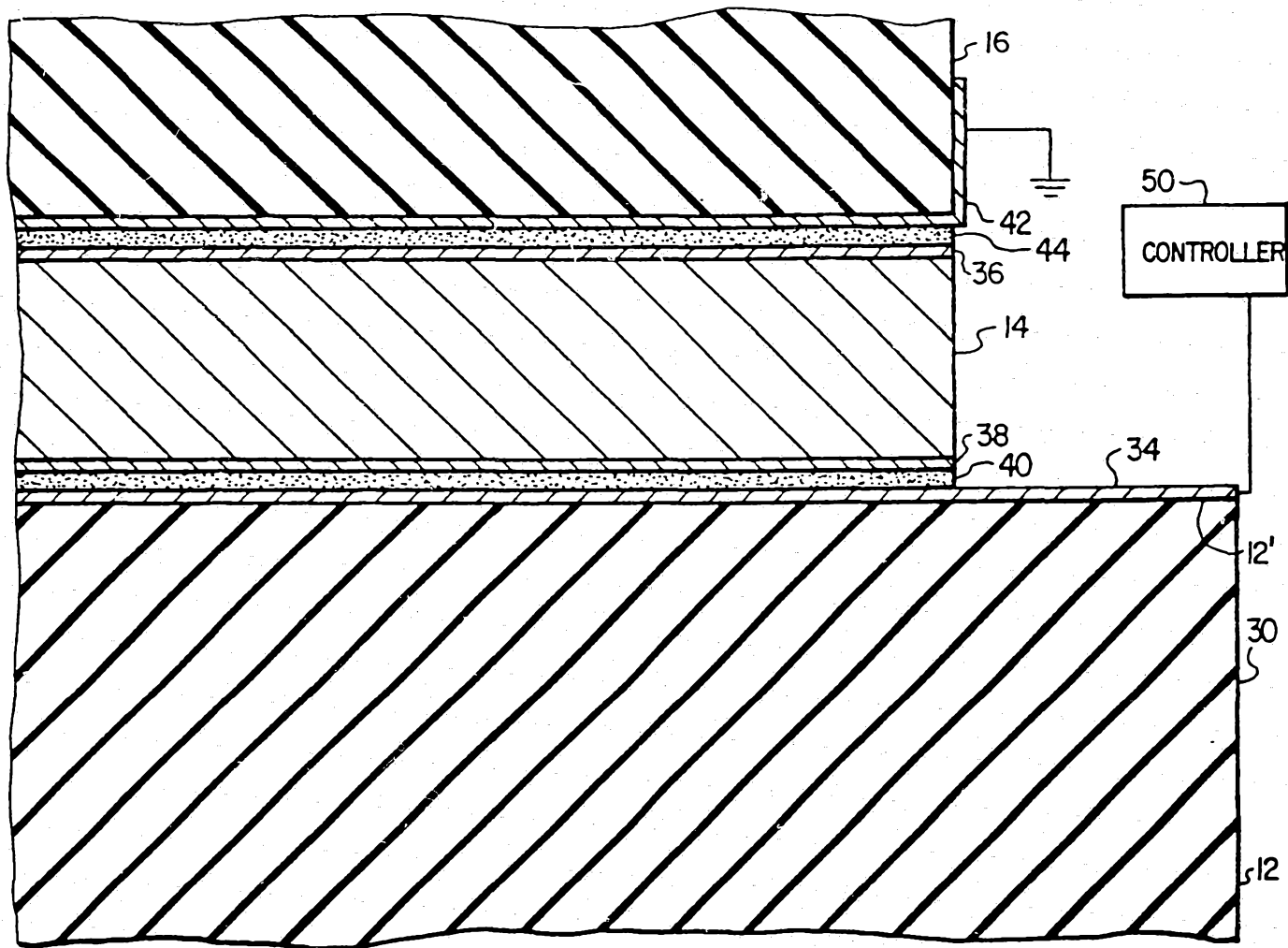

FIG. 6A

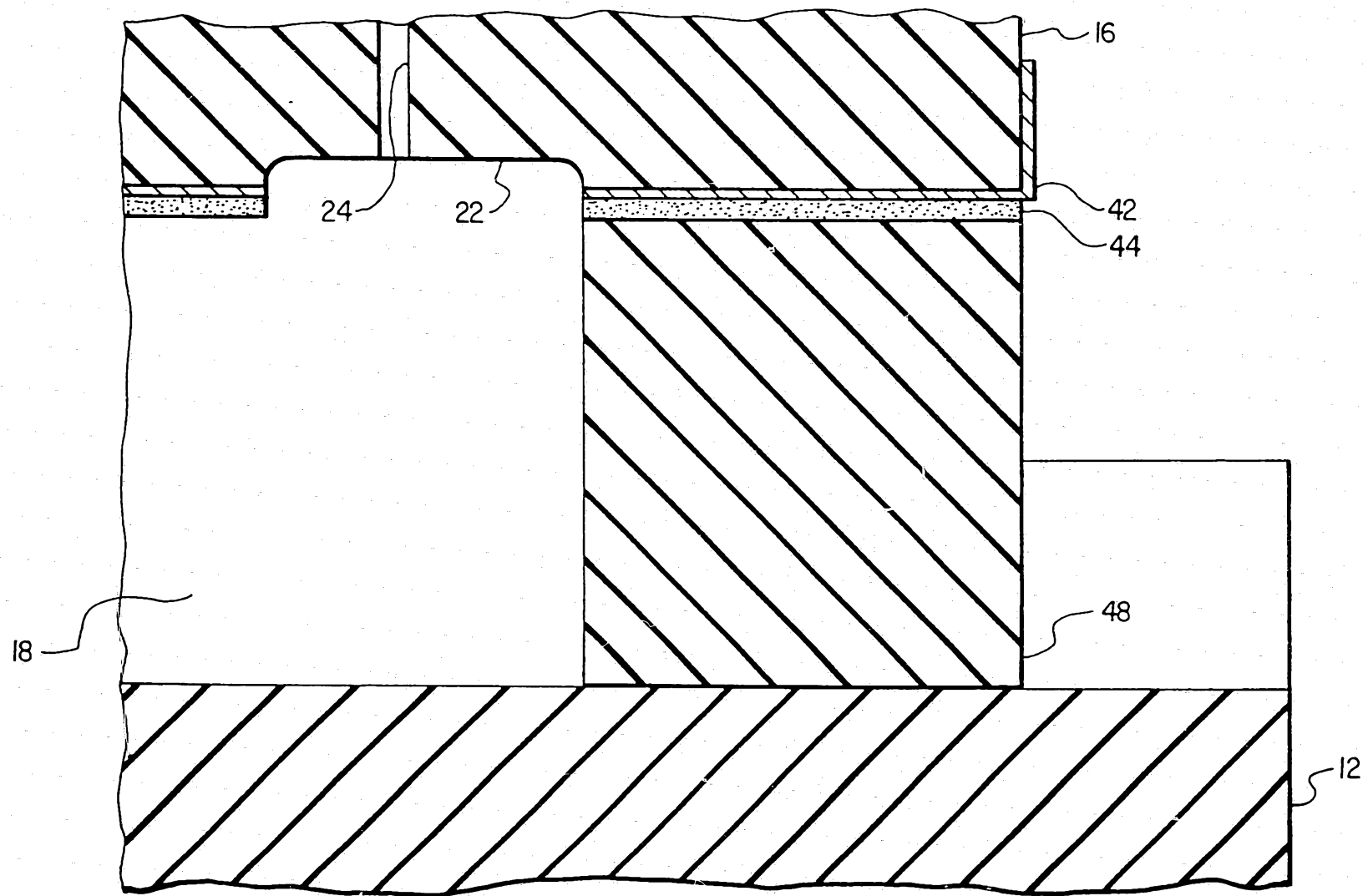

FIG. 6B

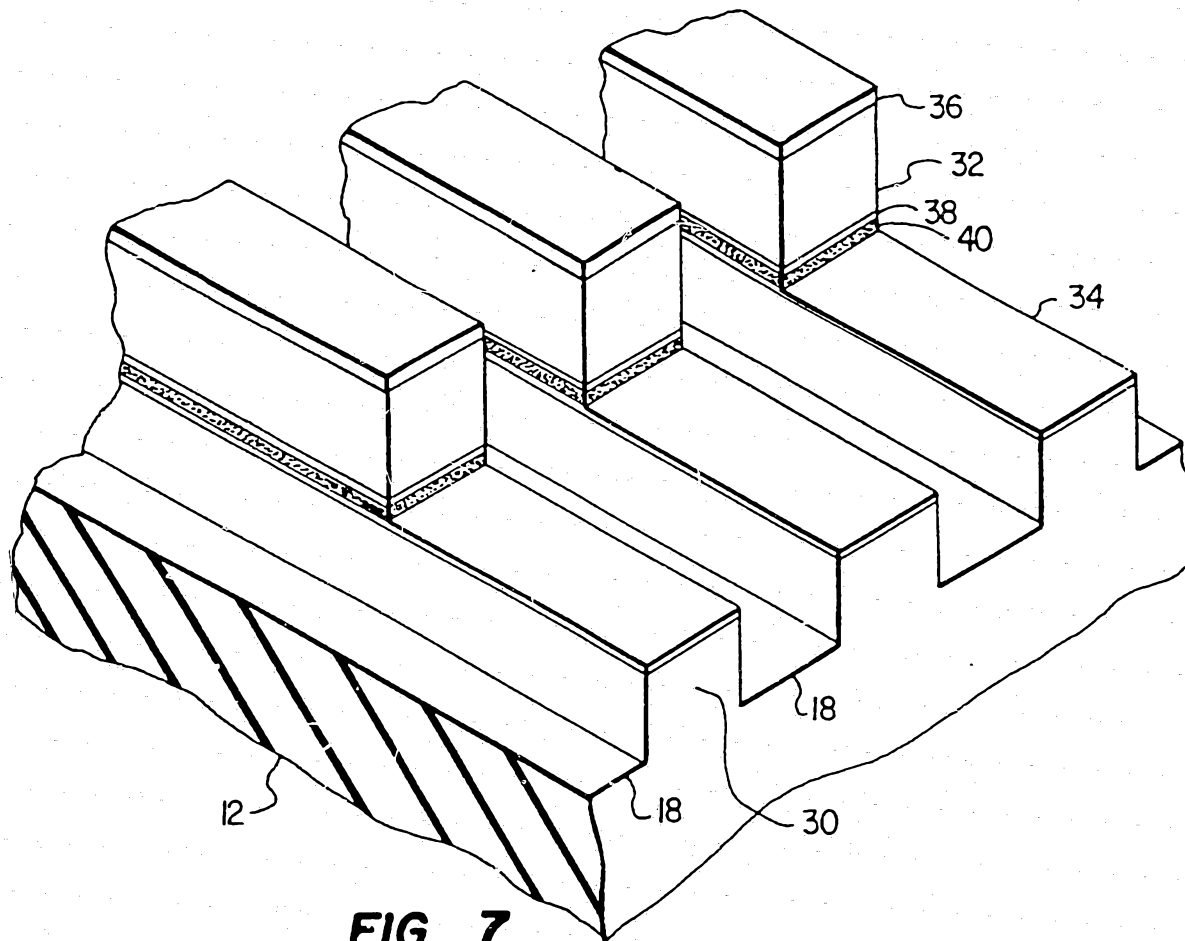

FIG. 7

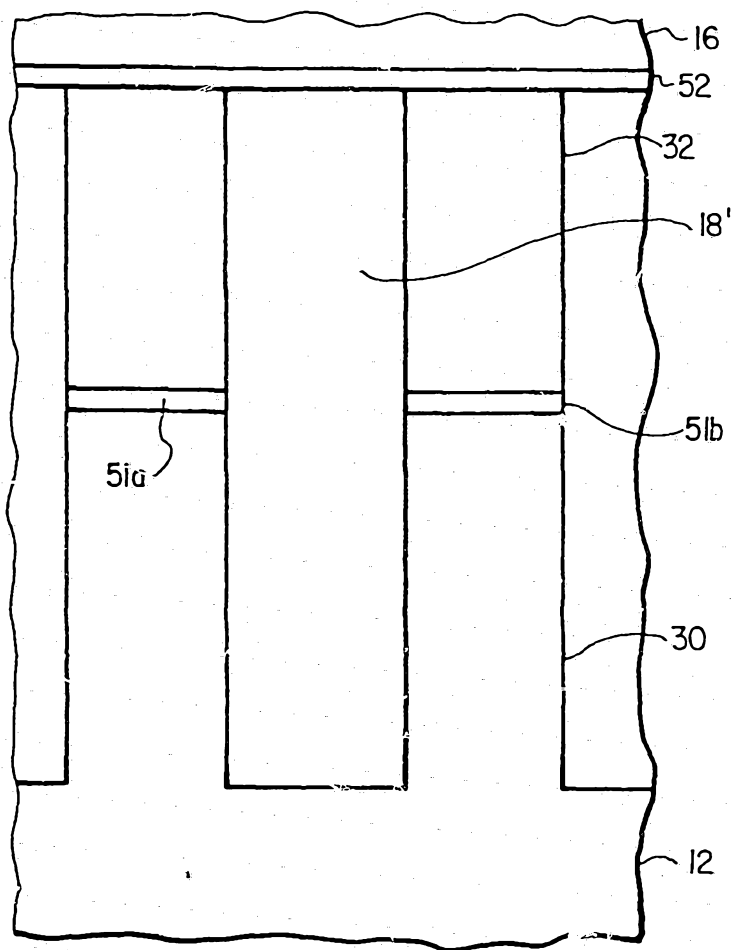

FIG. 9B

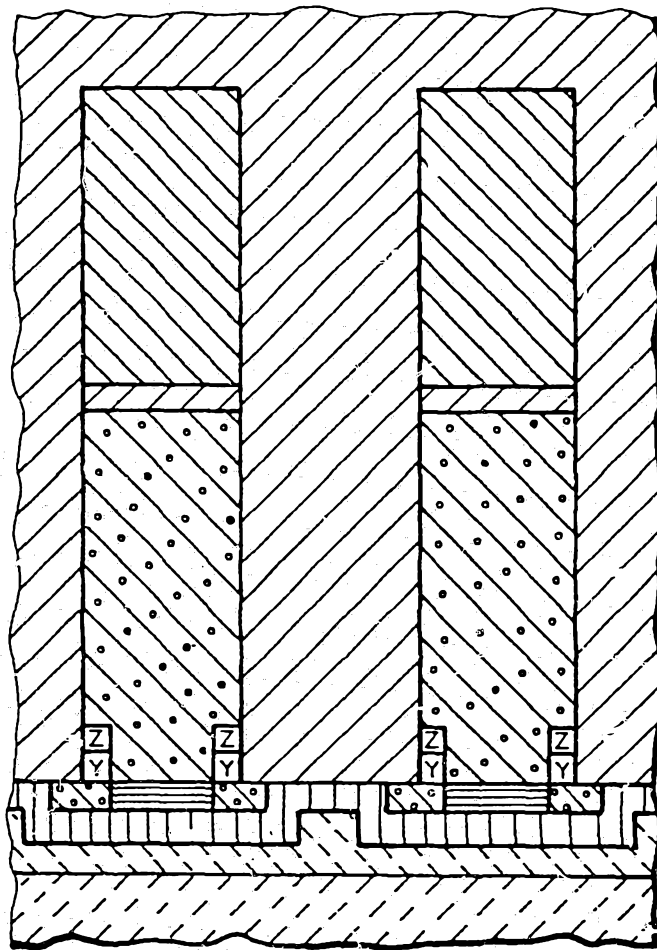











FIG. 9C

-  = 0.242×10^7
-  = 0.483×10^7
-  = 0.725×10^7
-  = 0.966×10^7
-  = 0.121×10^8
-  = 0.145×10^8
-  = 0.169×10^8
-  = 0.193×10^8
-  = 0.217×10^8

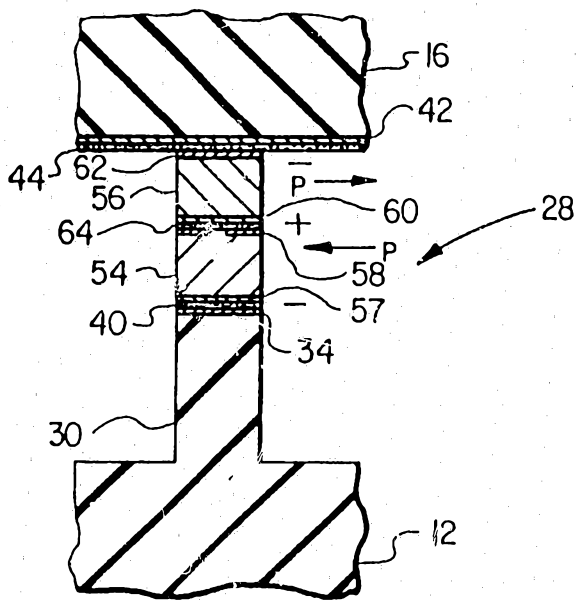

FIG. 10A

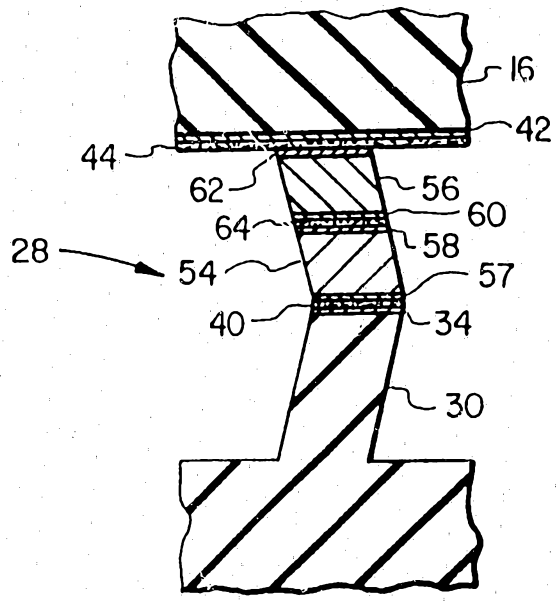

FIG. 10B

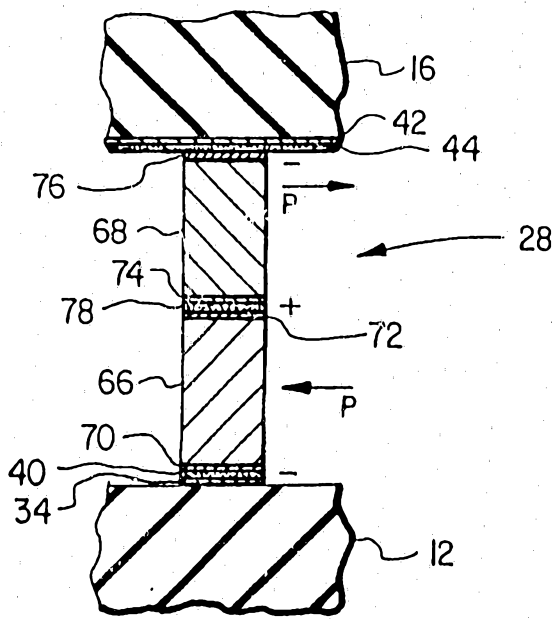

FIG. 11A

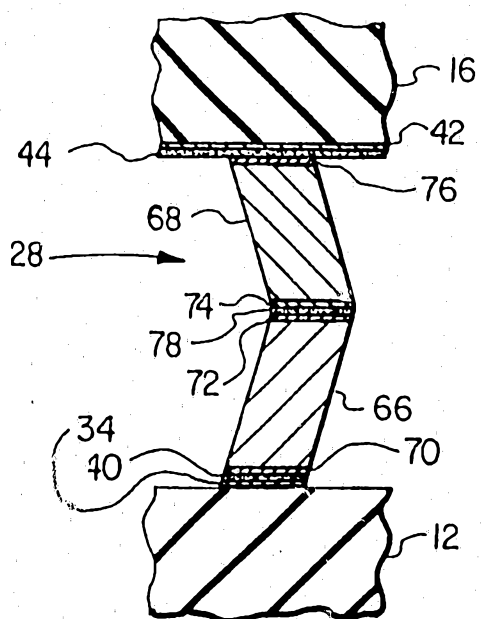

FIG. 11B

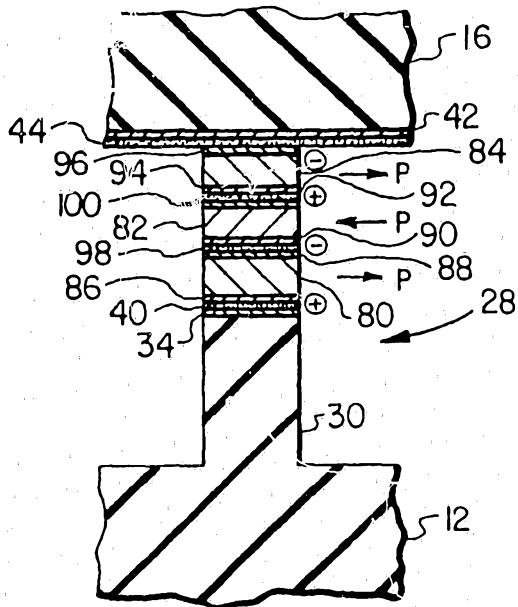

FIG. 12A

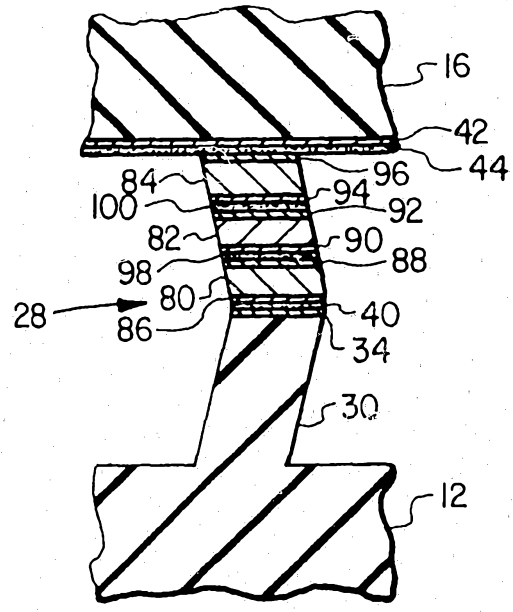

FIG. 12B

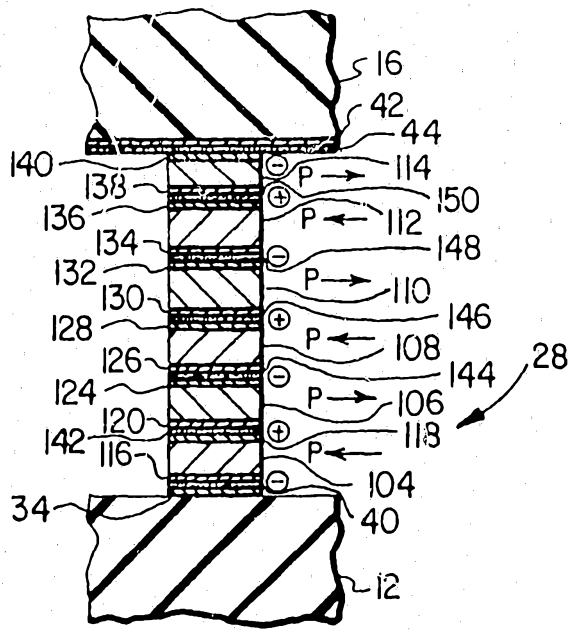

FIG. 13A

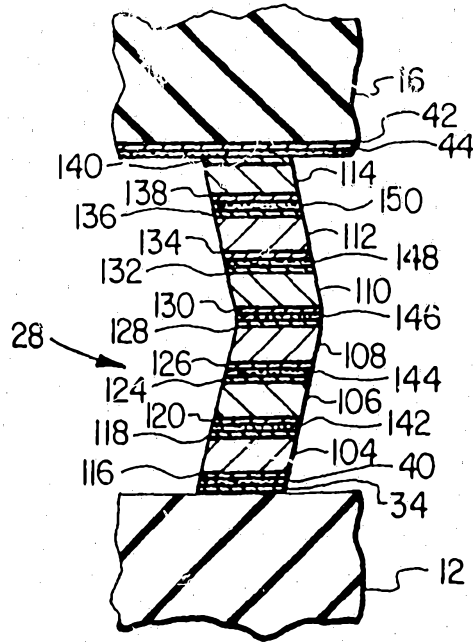

FIG. 13B

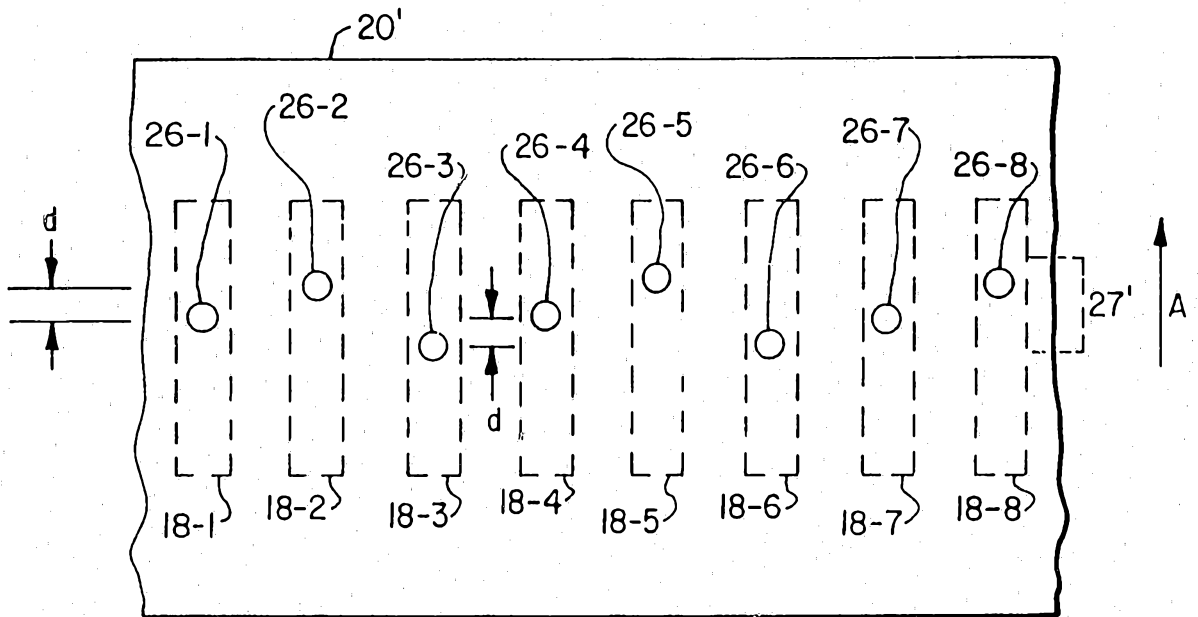

FIG. 15A

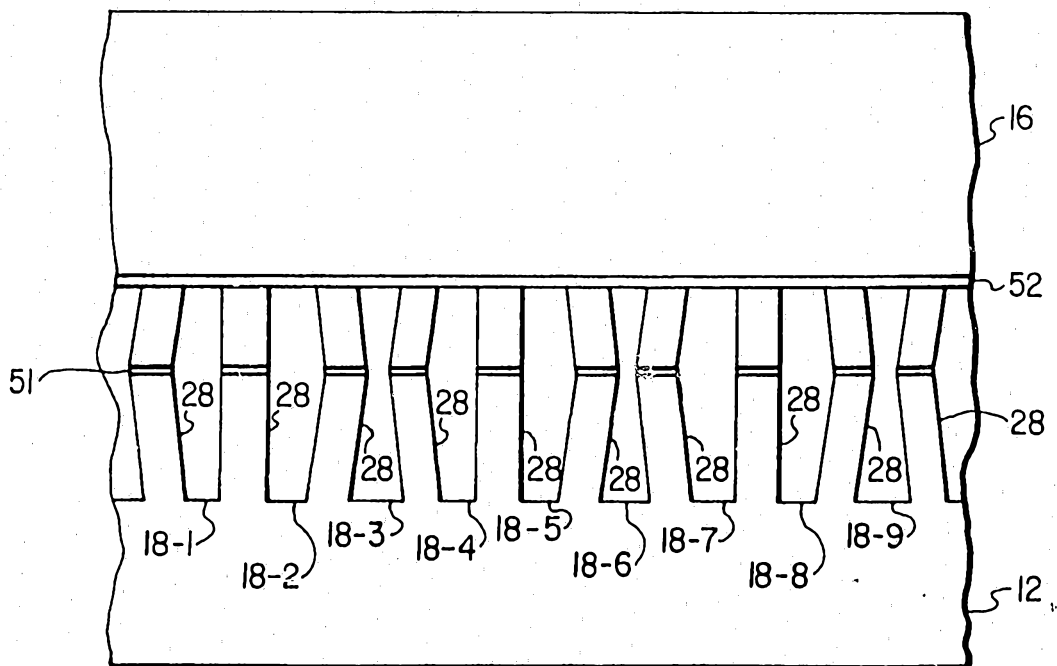

FIG. 15B

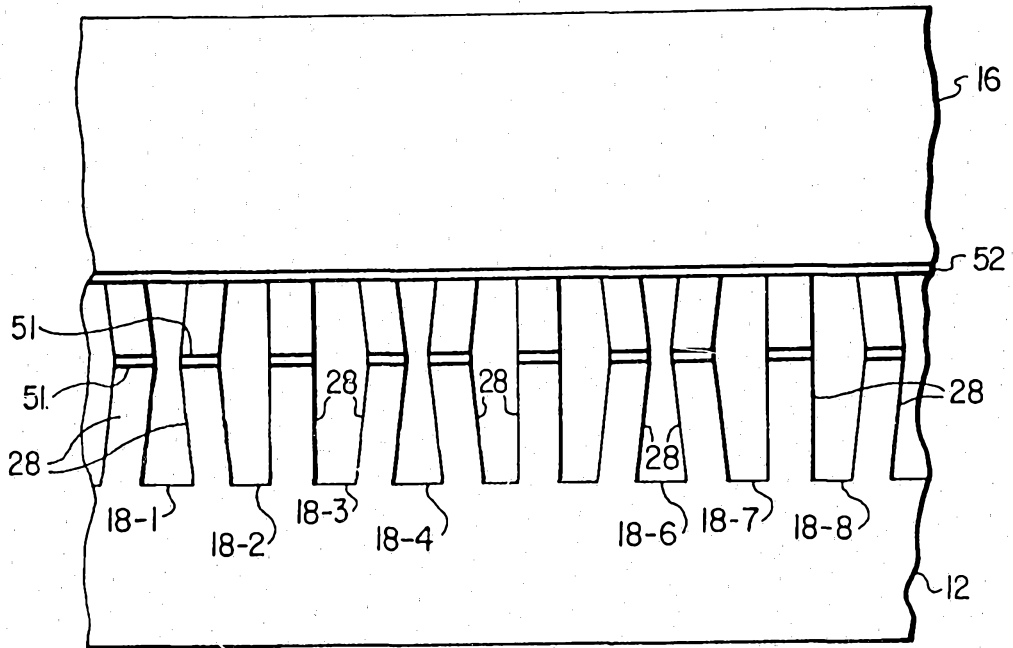

FIG. 15C

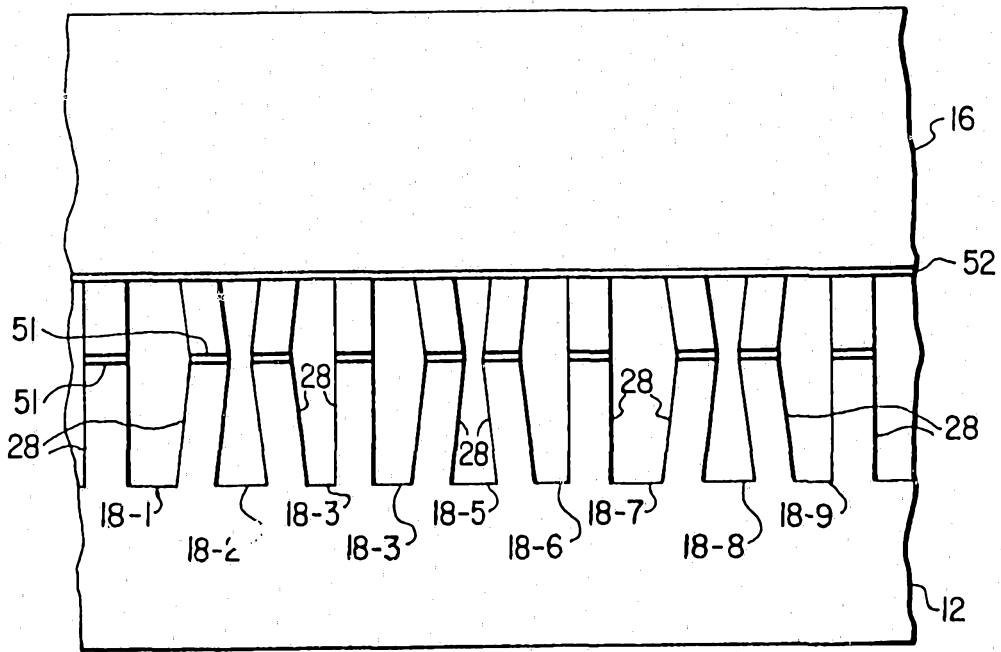

FIG. 15D