

(19)



(11)

EP 3 838 089 B1

(12)

EUROPEAN PATENT SPECIFICATION

(45) Date of publication and mention of the grant of the patent:
18.09.2024 Bulletin 2024/38

(51) International Patent Classification (IPC):
A47K 10/28^(2006.01)

(21) Application number: **19218314.3**

(52) Cooperative Patent Classification (CPC):
A47K 10/28; A47K 2010/3668; A47K 2010/3675

(22) Date of filing: **19.12.2019**

(54) DISPENSER, RETROFIT KIT FOR A DISPENSER, A METHOD FOR PROVISION OF PORTIONS OF A TISSUE WEB AND A METHOD FOR UPGRADING A DISPENSER

SPENDER, NACHRÜSTSATZ FÜR EINEN SPENDER, VERFAHREN ZUR BEREITSTELLUNG VON PORTIONEN EINER TISSUEBAHN UND VERFAHREN ZUM AUFRÜSTEN EINES SPENDERS

DISTRIBUTEUR, KIT DE RATTRAPAGE POUR DISTRIBUTEUR, PROCÉDÉ DE FOURNITURE DE PARTIES D'UNE BANDE DE TISSU ET PROCÉDÉ DE MISE À NIVEAU D'UN DISTRIBUTEUR

(84) Designated Contracting States:
AL AT BE BG CH CY CZ DE DK EE ES FI FR GB GR HR HU IE IS IT LI LT LU LV MC MK MT NL NO PL PT RO RS SE SI SK SM TR

• **ZIMMERMANN, Christoph**
69488 Birkenau (Buchklingen) (DE)

(43) Date of publication of application:
23.06.2021 Bulletin 2021/25

(74) Representative: **Eisenführ Speiser**
Patentanwälte Rechtsanwälte PartGmbH
Johannes-Brahms-Platz 1
20355 Hamburg (DE)

(73) Proprietor: **CWS International GmbH**
47119 Duisburg (DE)

(56) References cited:
EP-A1- 2 036 479 DE-B- 1 172 019
US-A- 4 718 588 US-A1- 2003 167 893

(72) Inventors:
• **RÜCKHEIM, Markus**
64347 Griesheim (DE)

EP 3 838 089 B1

Note: Within nine months of the publication of the mention of the grant of the European patent in the European Patent Bulletin, any person may give notice to the European Patent Office of opposition to that patent, in accordance with the Implementing Regulations. Notice of opposition shall not be deemed to have been filed until the opposition fee has been paid. (Art. 99(1) European Patent Convention).

Description

[0001] The invention relates to a dispenser for provision of portions of a tissue web, a retrofit kit for a dispenser, a method for provision of portions of a tissue web and a method for upgrading a dispenser.

[0002] Dispensers and methods for provision of portions of a tissue web are known, for example, from EP1191872B1, EP2810259B1, EP0283554B1, EP0483314B1. Existing dispensers and methods, however, in practice still have room for improvement regarding reliability and trouble-free operation.

[0003] EP 2 036 479 A1 discloses a towel dispenser in which a sensor is included which allows at least one marking on or in the towel material to be read, while a control unit is provided which allows the towel dispenser to be set on the basis of at least one marking and in which control unit setting possibilities are provided for functionalities of the towel dispenser, such as loop length, waiting times, dispensing patterns and the like, in conjunction with markings on towel material.

[0004] Therefore, it is an object of the present invention to provide an improved dispenser for provision of portions of a tissue web, an improved retrofit kit for a dispenser, an improved method for provision of portions of a tissue web and an improved method for upgrading a dispenser. In particular, it is an object of the present invention to provide a dispenser for provision of portions of a tissue web, a retrofit kit for a dispenser, a method for provision of portions of a tissue web and a method for upgrading a dispenser, which are highly reliable and/or reduce troubles and/or faults during operation.

[0005] This object is solved by a dispenser according to claim 1, a retrofit kit according to claim 11, a method for provision of portions of a tissue web according to claim 13 and a method for upgrading a dispenser according to claim 14.

[0006] According to a first aspect, it is provided a dispenser for provision of portions of a tissue web, comprising a first transport arrangement for unused tissue and a second transport arrangement for used tissue, a housing with a dispensing opening through which a tissue portion located between the first transport arrangement and the second transport arrangement protrudes, a detection arrangement comprising at least one sensor unit, preferably comprising a first sensor and a second sensor, for detecting a user change, a control unit adapted to activate the second transport arrangement when a user change is detected, characterized in that the detection arrangement is in an energy-saving sleeping mode by default and is adapted to raise to an active mode upon activation of the first transport arrangement, wherein the at least one sensor unit comprises a first sensor and a second sensor, and preferably a third sensor for detecting a user change; wherein two of said first, second and/or third sensors are an infrared sensor and an acceleration sensor, said acceleration sensor continuously detecting whether a user pulls the tissue or not and switch-

ing the infrared sensor from an inactive, energy-saving sleeping mode, to an active mode, if it is detected that a user pulls a tissue.

[0007] The dispenser is preferably suitable for wash-rooms and other hygienic environments. The dispenser comprises a housing. The housing preferably comprises a back part and an openable housing cover with a front face. The housing further has a dispensing opening.

[0008] The tissue to be dispensed from the dispenser can be a multiuse tissue, such as a cloth towel or micro-fiber towel, or a single-use tissue, such as a paper tissue or a reinforced paper tissue, for example. The tissue is preferably provided as a continuous web, for example coiled up to a tissue roll or folded in a stack, e.g. concertina-like.

[0009] Portions of the tissue web, which preferably means a certain length of tissue to be used by a user, often for drying hands, are provided by the dispenser. The portion to be used by a user protrudes through dispensing opening in the housing, such that the user can access the portion. Preferably, the portion is provided as a, preferably hanging, loop of tissue web. For example, the dispensing opening may have a front and a back slot, preferably separated by an intermediate part of the housing. For example, a part of the tissue portion facing the user may protrude through the front slot and a part of the tissue portion facing the wall (in a wall-mounted dispenser) may protrude from the back slot.

[0010] Preferably, the dispensed and used portions of tissue can be retrieved and coiled, for example within the dispenser. Usually, the used multiuse tissue is removed by service personnel, washed and recycled, and then provided for a further use cycle. Once a tissue roll is empty, usually a new tissue roll, which also can be a recycled tissue roll, is inserted into the dispenser and received there by some form of holding arrangement.

[0011] The dispenser comprises a first transport arrangement for unused tissue and a second transport arrangement for used tissue. The tissue portion protruding through the dispensing opening is located between the first transport arrangement and the second transport arrangement. Preferably, the first transport arrangement is adapted to provide unused tissue in the form of a continuous web by uncoiling it from a roll of unused tissue. Further preferably, the second transport arrangement is adapted to retrieve used tissue, preferably by coiling it to a used tissue roll.

[0012] Dispensers with a first and second transport arrangement, in particular dispensers with a multiuse tissue web that is retrieved after use, can also be referred to as retracting dispensers.

[0013] The dispenser further comprises a control unit adapted to activate the second transport arrangement. Preferably, the control unit is further adapted to activate the first transport arrangement and/or to deactivate the first transport arrangement and/or to deactivate the second transport arrangement. Further preferably, the control unit can be adapted to control further elements of the

dispenser.

[0014] The dispenser further comprises a detection arrangement. The detection arrangement has at least one sensor unit for detecting a user change. In particular, the detection of a user change is meant as a detection of a change in the person using the dispenser. For example, the detection of a user change can comprise the detection of a change in the position of a person using the dispenser in combination with the detection of the end of a use and/or the beginning of a new use. Preferably, the detection of a user change can comprise the detection of the departure of a user, possibly including the departure speed of a user, and/or the approach of a user, possibly including an approach speed.

[0015] The sensor unit comprises a first sensor and a second sensor. In particular, the first sensor and the second sensor can be employed for together detecting a user change, for example having a first sensor detecting a change in the position of the person using the sensor and the second sensor detecting the end and/or beginning of a use.

[0016] The sensor unit comprises two or more sensors, e.g. a first and a second sensor and possibly further sensors like a third, fourth or further sensors. The sensor(s) of the sensor unit can be separate sensors. The sensor(s) of the sensor unit also can be integral and/or an integrated sensor and/or integrated into one single sensor element. For example, the sensor unit and/or one of its sensor(s) can be adapted to generate one or more sensor signals, e.g. based on one or more detection principles and/or one or more detection fields, wherein the detection principles may be the same or different ones and/or the detection fields may be the same or different ones.

[0017] The detection arrangement and/or the sensor unit, in particular the first sensor and a second sensor, is connected to further components of the dispenser, for example the control unit, in a wired or wireless way. The sensor(s) of the detection arrangement and/or the sensor unit can be connected to each other and/or to further components of the dispenser, for example the control unit, in a wired or wireless way.

[0018] The control unit of the dispenser is adapted to activate the second transport arrangement upon detection of a user change by the detection arrangement. In particular, it is preferred that such an activation of the second transport arrangement results in the at least partial retraction of the tissue portion protruding through the dispensing opening back into the housing of the dispenser, in particular by coiling the used tissue on a used tissue roll by the second transport arrangement.

[0019] The solution as described herein is based on the finding that existing dispensers and methods for providing portions of tissue have drawbacks in particular in high-frequency operating situations. High-frequency operating situations typically are situations where a high number of users intends to use the dispenser in quick succession. Existing dispensers, in particular retracting dispensers, may not be adapted for such a high-frequency

use. In particular, the retrieving of used tissue by a second transport arrangement may be too slow or too delayed for such a quick succession of uses. Typically, in retracting dispensers, the retrieval of used tissue by the second transport mechanism takes place after a certain time after unused tissue has been provided to the dispensing opening. The reason for this delay of the retrieval of the used tissue portion is to give a user sufficient time to use the portion of tissue protruding through the dispensing opening. The use of this tissue portion typically takes place by a user grabbing the tissue portion and moving it over his hands for drying hands. A retrieval of used tissue by the second transport arrangement directly after provision of the tissue portion by the first transport arrangement would result in the user not having a large enough portion protruding from the dispensing opening for actually accessing this tissue portion and using it for drying the hands.

[0020] While this operating principle has a number of advantages and make sense in a number of regular or low-frequency operating situations, it does have drawbacks in high-frequency operating situations. When a quick succession of users activates the provision of tissue portions from a reservoir of unused tissue, in particular via the first transport arrangement, to protrude through the dispensing opening in a higher frequency than the used tissue is retrieved by the second transport arrangement, the tissue portion protruding from the dispensing opening will get larger and larger over time. It often happens that the tissue portion protruding from the dispensing opening in such a situation gets too large and thus too heavy to be retrieved by the second transport arrangement. This can lead to so-called "floor loops", in which the tissue portion protruding from the dispensing opening becomes so large that it reaches the floor of a washroom.

[0021] The solution as described herein is based on the finding that such drawbacks can be avoided when the second transport arrangement is activated as soon as the person using the dispenser changes. Thus, the solution as described herein provides for a detection arrangement for detecting a user change and a control unit for activating the second transport arrangement upon such detection. When in a high-frequency operating situation the user takes shorter time to dry his or her hands than the usual delay for retrieving the used tissue, the solution described herein detects such a user change and activates the second transport arrangement. This has the advantage that as soon as a user change occurs, the retrieval of the used portion can be initiated. In this way, it can be avoided that two or even more times an unused tissue portion is provided through the dispensing opening before a used tissue portion is retrieved. Increasingly large loops, and even floor loops, can be avoided in this way.

[0022] The control unit preferably is connected to various components of the dispenser using a wired or wireless connection in order to transfer signals, e.g. sensor

signals, activation signals, deactivation signals, control signals and the like, and to generate and/or process and/or receive and/or transmits such signals. Further preferably, the control unit may, using either a wireless or wired connection, also be connected to external components, for example a washroom information system, an external communication unit and/or a backend unit.

[0023] The control unit preferably is adapted to communicate with an external communication unit and/or with a backend unit, preferably in a bidirectional way and/or in a wireless way. Preferably, information can be transferred from the control unit to the external communication unit and/or to the backend unit. Further preferably, information, such as software updates and/or settings and/or update of (operational) parameters, can be received from the external communication unit and/or from the backend unit by the control unit. It is further preferred that the external communication unit and/or the backend unit is adapted and arranged to communicate, preferably in a bidirectional way, with a plurality of arrangements and/or a plurality of dispensers. For example, the wireless communication can be realized by a Bluetooth connection. Further preferably, the external communication unit and/or the control unit is adapted and arranged to communicate, preferably in a wireless way, such as Bluetooth, to a backend unit, in particular in order to exchange client specific and/or process related information. Further preferably, the control unit and/or the external communication unit and/or the backend unit is adapted and arranged to communicate with one or more mobile devices like tablets and/or smart phones, preferably in a bidirectional way and/or in a wireless way.

[0024] Preferably, the dispenser can be part of a system further comprising an external communication unit and/or a backend unit and/or one or more mobile devices.

[0025] In a preferred embodiment, the control unit is adapted to activate the first transport arrangement when a user change is detected. In this embodiment, the event of a user change can also trigger the activation of the first transport arrangement, which preferably results in dispensing a further unused portion of tissue web through the dispensing opening. In this way, the new user does not need to activate, for example manually or via an automatic, e.g. non-touch, activation mechanism, the provision of a new portion of tissue web. Rather, by activating the first transport arrangement upon detection of a user change, the new user will be provided with an unused tissue portion without the need for further action from his or her side.

[0026] Preferably, the detection arrangement, in particular the sensor unit, comprises a third and/or fourth and/or further sensor(s) for detecting a user change. Preferably, also the third and/or fourth and/or further sensor(s) for detecting a user change can have the features, characteristics and advantages as described herein for the first and/or second sensor. Further, it is preferred that a combination of the sensors of the detection arrangement and/or the sensor unit or all sensors of the detection

arrangement and/or the sensor unit contribute to the detection of a user change. For example, some or all of the sensors of the detection arrangement and/or the sensor unit, in particular their individual sensor signals, may be used and/or assessed as a whole, and/or interdependently, in order to detect a user change. In particular, the detection arrangement and/or the sensor unit and/or the control unit can be adapted to detect a user change and/or to activate the second transport arrangement upon detection of a user change depending on a combination of signals from a plurality or all of the sensors of the detection arrangement and/or the sensor unit.

[0027] Preferably, the first sensor and/or the second sensor and/or the third sensor and/or the fourth sensor and/or the further sensor(s) can have the same or different detection principles. For example, the sensors can be of the same or different types. In this way, the accuracy and reliability of the detection of a user change can be improved.

[0028] Further preferably, the first sensor and/or the second sensor and/or the third sensor and/or the fourth sensor and/or the further sensor(s) can have the same or different detection fields. For example, the detection fields of the sensor(s) can vary, e.g. regarding their size and/or range and/or direction and/or sensibility. Again, in this way, the accuracy and reliability of the detection of a user change can be improved. Further preferably, a detection field can be directed upwards, downwards, sideward, forward, rearward or any combination thereof.

[0029] Preferably, the detection arrangement and/or the sensor unit and/or at least one of or all of the sensor(s) can be arranged such that the detection field can be adjusted. For example, the detection arrangement and/or the sensor unit and/or at least one of or all of the sensor(s) can be pivotable, e.g. about a horizontal and/or about a vertical pivot axis. This has the advantage that the detection arrangement can be adjusted, for example for different operating situations.

[0030] In particular, it can be preferred that at least one of the sensors and/or the sensor unit has a detection field in the direction of a user. A detection field in the direction of a user can be directed towards the torso of a user and/or towards the (likely) position of the user's hands during the drying process. For example, a detection field in the direction of a user can be substantially horizontal and/or angled downwards and/or angled upwards.

[0031] Further, it can be preferred that at least one of the sensors and/or the sensor unit has a detection field in the direction of the tissue web, in particular in the direction of the protruding portion of the tissue web, in particular its part facing the user.

[0032] In a preferred embodiment at least one of the sensors and/or the sensor unit is positioned on a front face of the dispenser, in particular on a lower part thereof. Preferably, at least one of the sensors and/or the sensor unit can be positioned adjacent or near the dispensing opening. Further preferably, at least one of the sensors and/or the sensor unit is positioned on an intermediate

part of the dispenser housing. Further preferably, at least one of the sensors and/or the sensor unit is positioned inside the housing and/or arranged at the housing, in particular on its outside or on its inside, and/or separate from the dispenser, e.g. next to the dispenser.

[0033] In particular, different combinations of the details of individual sensors can be preferred to create a detection arrangement and/or a sensor unit having a high speed and/or high accuracy and/or high reliability and/or short reaction time in detecting a user change while at the same time having a low energy consumption.

[0034] For example, the first sensor and/or the second sensor and/or the third sensor and/or the fourth sensor and/or the further sensor(s) can be chosen from the following group of sensors, comprising or consisting of: acceleration sensor, motion sensor, thermal sensor, infrared sensor, radiation sensor, in particular electromagnetic radiation sensor, optic sensor, time-of-flight sensor, capacitive sensor, image sensor, reflective sensor, pyroelectric (passive) infrared sensor, thermopile sensor.

[0035] In particular, sensors are preferred having sharp signals and/or low noise and/or fast response time and/or low energy consumption.

[0036] According to the invention the sensor unit has at least an infrared sensor and an acceleration sensor. As described above, these two sensors of the sensor unit can be separate sensors or implemented as an integrated sensor, providing for both infrared detection and acceleration detection, for example. An acceleration sensor with a low energy consumption is used for continuously detecting whether a user pulls the tissue or not. If it is detected that a user pulls a tissue, the infrared sensor (and possibly also a control unit) preferably is switched from an inactive, energy-saving mode, to an active mode. The infrared sensor then preferably detects whether a user approaches and/or leaves the dispenser. The infrared sensor and the control unit can be arranged on a single circuit board, for example.

[0037] In general, the sensor(s) and/or detection principles and/or detection fields used herein are preferably adapted to detect a user change independent from and/or despite possibly interfering factors such as light, e.g. sunlight, artificial light, UV light, and/or radiation, in particular electromagnetic radiation, and/or electromagnetic fields and/or reflective and/or colored surfaces and/or heat sources like radiators.

[0038] Further, it is preferred that the sensitivity and/or the detection field of the detection arrangement and/or the sensor/ and/or at least one of or all of the sensor(s) can be adjusted. For example, the detection field of a sensor, e.g. of an infrared sensor, can be enlarged or reduced. This can be realized, for example, by positioning a sensor, e.g. an infrared sensor, behind a plate with a hole, acting as an aperture. By varying the distance between the sensor and the plate with a hole, the sensitivity and/or the detection field can be varied.

[0039] Further preferably, at least two of the first sensor and/or the second sensor and/or the third sensor and/or

the fourth sensor or the further sensor(s), preferably three or more or all of the sensors, are arranged on a single circuit board, in particular a single printed circuit board.

[0040] Preferably, also the control unit can be arranged on the same single circuit board, in particular on the same single printed circuit board. Alternatively, the control unit can be provided on a separate (printed) circuit board. The provision of several components on a single circuit board has the advantage of a compact and solution which is easy to manufacture and/or to install and/or to exchange and/or to service. A single circuit board also has a cost advantage and can be less susceptible to interference than a cable connection, since unshielded cables may act as antennas and may emit interference signals.

[0041] In a further preferred embodiment, the second transport arrangement comprises a blocking element, wherein the activation of the second transport arrangement via control unit comprises the release of the blocking element. The blocking element of the second transport arrangement preferably is adapted to block the activation of the second transport arrangement, preferably for a certain time. In particular, it is preferred that the blocking element is adapted to block the second transport arrangement for a certain period of time after the activation of the first transport arrangement. Further preferably, the blocking element is adapted to be released after a certain period of time. Further preferably, the second transport arrangement is adapted to automatically, for example via a biasing mechanism, such as a spring or an electrically driven mechanism, to retrieve the used portion of tissue web once the blocking element is released.

[0042] When such a blocking element is present, it is particularly preferred that the activation of the second transport arrangement via the control unit comprises the release of the blocking element. In particular, in case the second transport arrangement is adapted to retrieve the used portion of tissue web once the blocking element is released, the activation of the second transport arrangement may consist simply in the release of the blocking element. Further preferably, the blocking element can be coupled with the activation of the first transport arrangement such that the second transport arrangement will automatically be blocked once the first transport arrangement has been activated.

[0043] In a preferred embodiment, the blocking element is a time controlled, preferably mechanical, blocking element. A time controlled blocking element preferably is released after a predetermined amount of time. The blocking element can be a mechanical and/or an electric blocking element and/or a blocking element based on a different blocking principle.

[0044] In a further preferred embodiment, the second transport arrangement comprises a release element adapted to release the blocking element.

[0045] In particular, the release element is adapted to release the blocking element before the predetermined time of a time controlled blocking element. The activation

of the second transport arrangement, for example, can comprise the activation of the release element, which then in turn releases the blocking element and thus enables the automatic retrieval of the used portion of tissue web by the second transport arrangement.

[0046] For example, the release element comprises a valve, in particular an electric valve and/or a solenoid valve, and/or a drive, in particular an electric drive.

[0047] For example, the release element can comprise an electrically driven solenoid valve which interacts with a, for example, pneumatic blocking element in order to release it. Preferably, the release element as a low energy consumption and/or is adapted to be battery-supplied.

[0048] The first transport arrangement can comprise a manual transport mechanism and/or an automatic transport mechanism, in particular a driven transport mechanism, preferably electrically driven, e.g. via a battery supply and/or other energy supply. A manual transport mechanism for the first transport arrangement preferably is operated by action of a user, only, e.g. by a user pulling the tissue, which preferably leads to a corresponding provision of tissue, e.g. by decoiling and possibly guiding the tissue via rolls to the dispensing opening. Preferably, a manual transport mechanism does not need any energy supply, e.g. in the form of batteries or a power line.

[0049] The second transport arrangement can comprise a manual transport mechanism and/or an automatic transport mechanism, in particular a driven transport mechanism, preferably electrically driven, e.g. via a battery supply and/or other energy supply. A manual transport mechanism for the second transport arrangement preferably is independent from, in particular electric, energy supply, e.g. in the form of batteries or a power line. Preferably, the manual transport mechanism for the second transport arrangement operates by tensioning and releasing a biasing element, such as a spring, and/or via a, preferably mechanical, coupling with the first transport mechanism.

[0050] For example, the dispenser can be a so-called "non-touch" dispenser where the activation of the first transport arrangement for dispensing a portion of unused tissue is realized without having the user making contact with the dispenser of the tissue. For example, a user's presence in front of the dispenser can be detected and the first transport arrangement can be activated thereupon. The detection of a user's presence can be detected, for example, via the detection arrangement described herein and/or via a separate detection unit, which may be specifically adapted for detecting whether a user holds his or her hand in front of a detection area of the dispenser, for example.

[0051] The detection arrangement is in an energy-saving sleeping mode by default and is adapted to raise to an active mode upon activation of the first transport arrangement. This is advantageous to save energy consumption. For example, the control unit can be adapted to raise the detection arrangement from the energy sav-

ing sleeping mode to an active mode upon activation of the first transport arrangement. Alternatively or additionally, a switch can be provided, for example a reed switch. Preferably, such a switch is switched upon activation of the first transport arrangement. The switching of the switch preferably results in raising the detection arrangement from energy savings sleeping mode to an active mode. For example, a reed switch can be positioned in the vicinity of the blocking element. A magnet can be positioned on the blocking element such that when the blocking element reaches its blocking position (in particular, when or after the first transport arrangement has been activated), the magnet on the blocking element switches the reed switch and thus initiates the raising of the detection arrangement to the active mode.

[0052] According to a further preferred embodiment the control unit is adapted to activate the second transport arrangement when a repeated activation of the first transport arrangement by a single user is detected. In practice, situations can arise where a user wants to use more than one portion of tissue web and thus repeatedly activates the first transport arrangement. In such a situation, it is preferred that increasingly large loops, in particular "floor loops", are avoided. Thus, it is advantageous to detect the repeated activation of the first transport arrangement by the same user, i.e. a repeated activation of the first transport arrangement without detecting a user change, and to activate the second transport arrangement, in particular for retrieval of the used tissue portion, in such a situation. In addition, maintenance and service calls and costs can be reduced, and the availability of the dispenser for the operator can be increased.

[0053] Increasingly large loops are heavy and harder to retrieve by the second transport arrangement and thus put additional wear on the second transport arrangement. By providing solutions for avoiding increasingly large loops, the lifespan and reliability of the second transport arrangement can be increased.

[0054] In a further preferred embodiment the control unit is adapted to activate the second transport arrangement when a departure speed of a user is detected that is above a threshold value, in particular in case such a departure speed is detected after a certain amount of time has elapsed after a manual activation of the first transport arrangement by a user.

[0055] When the first transport arrangement is a manual activation mechanism, such as in dispensers where the user actively pulls the tissue web, movements may occur right after the pulling of the tissue by the user that resemble a high departure speed. Therefore, the activation of the second transport arrangement in case of a high departure speed is particularly preferred only after a certain amount of time after a manual activation of the first transport arrangement.

[0056] Individual or all embodiments relating to the dispenser, in particular the detection arrangement and/or the control unit, can be combined and have particular advantages, also in the specific combinations.

[0057] According to a further aspect, it is provided a retrofit kit for a dispenser according to at least one of the preceding claims, the retrofit kit comprising a detection arrangement comprising at least a first sensor and a second sensor, for detecting a user change a control unit adapted to activate a second transport arrangement of the dispenser when a user change is detected.

[0058] It is particularly preferred that the retrofit kit comprises a release element adapted to release a blocking element of the second transport arrangement of the dispenser.

[0059] According to a further aspect, it is provided a method for provision of portions of a tissue web according to claim 13, the method comprising transporting unused tissue and transporting used tissue such that a tissue portion located between a first transport arrangement and a second transport arrangement protrudes through a dispensing opening in a housing of a dispenser, detecting a user change, in particular with a detection arrangement comprising at least one sensor unit, comprising a first sensor and a second sensor; activating the second transport arrangement when a user change is detected.

[0060] According to a further aspect, it is provided a method for upgrading a dispenser for provision of portions of a tissue web, the method comprising installing a retrofit kit as described herein in a dispenser for provision of portions of a tissue web, the dispenser comprising a first transport arrangement for unused tissue and a second transport arrangement for used tissue and a housing with a dispensing opening through which a tissue portion located between the first transport arrangement and the second transport arrangement protrudes. As to the advantages, preferred embodiments and details of these further aspects and their preferred embodiments, reference is made to the corresponding advantages, preferred embodiments and details described above.

[0061] Preferred embodiments shall now be described with reference to the attached drawings, in which

Fig. 1: shows an example of a wall-mounted dispenser with three users in a high-frequency operating situation;

Fig. 2: shows a side view of an example of a dispenser with first and second transport arrangements;

Fig. 3: shows examples of two dispensers with two different detection principles;

Fig. 4: shows examples of three sensors with three different detection principles;

Fig. 5: shows an example of a dispenser in different stages of use and a possible detection principle;

Fig. 6: shows a detail of a section of an example of a dispenser with a second transport arrangement and a front slot of a dispensing opening;

Fig. 7: shows side views of examples of three dis-

pensers with different positions of sensors having detection fields in different directions;

Fig. 8: shows an example of a dispenser over a washbasin;

Fig. 9: shows an example of a dispenser with a sensor having a detection field in the direction of a user;

Fig. 10a: shows a further example of a dispenser with a sensor having a detection field in the direction of a user;

Fig. 10b: shows an example of a dispenser with a sensor having a detection field in the direction of a user where three users queue in line;

Fig 11: shows an example of a dispenser with a sensor having a detection field in the direction of the hands of a user;

Fig 12: shows a further example of a dispenser with a sensor having a detection field in the direction of the hands of a user;

Fig 13: shows an example of a dispenser over a washbasin having a detection field in the direction of the hands of a user;

Fig 14: shows an example of a blocking element of a second transport arrangement and a release element;

Fig 15: shows an example of a first schematic set up of a detection arrangement and a control unit;

Fig 16: shows an example of a second schematic set up of a detection arrangement and a control unit;

Fig 17: shows an example of a schematic basic set up of sensors on a printed circuit board;

Fig 18: shows an example of a schematic flow diagram of an activation of the second transport arrangement;

Fig 19: shows two examples of a sensor output evaluation;

Fig 20: shows an example of an evaluation of sensor data of a first sensor;

Fig 21: shows an example of an evaluation of sensor data of a second sensor;

Fig 22: shows an example of a schematic flow diagram of a method for provision of portions of a tissue roll; and

Fig 23: shows an example of a schematic flow diagram of a method for upgrading a dispenser for provision of portions of a tissue web.

[0062] In the figures, elements with the same or comparable functions are indicated with the same reference numerals.

[0063] Figure 1 shows an example of a wall-mounted dispenser 1 with three users U in a high-frequency operating situation. Figure 2 shows a dispenser 1 in a side view.

[0064] The dispenser 1 for provision of portions of a

tissue web 30 has a first transport arrangement 41 and a second transport arrangement 42. In the figures, only schematic parts of the first and second transport arrangement 41, 42 are shown. Further, the dispenser 1 has a housing 10 with a back part 13, in particular for wall mounting the dispenser 1, and an openable housing cover 11 with a front face 12. The dispenser 1 further has a dispensing opening 20 comprising a front slot 21 and a back slot 22. The front slot 21 and the back slot 22 are separated by an intermediate part 14 of the housing 10.

[0065] A tissue portion 33 located between the first transport arrangement 41 and the second transport arrangement 42 protrudes through the dispensing opening 20. The tissue portion 33 protruding through the dispensing opening 20 has the form of a loop, as can be seen in Figure 1, for example. A part 33a of the tissue portion 33 faces the user U and a part 33b of the tissue portion 33 faces the wall or away from the user. Typically, the part 33a of the tissue portion 33 facing the user is unused. The part 33b of the tissue portion 33 facing the wall may be used.

[0066] Preferably, unused tissue 31 is provided in a coiled form as a roll and dispensed through the front slot 21 of the dispensing opening 20 by the first transport arrangement 41. Once a user U has dried his or her hands, the part 33b of the tissue portion 33 facing the wall is retracted through the back slot 22 of the dispensing opening 20 via the second transport arrangement 42 and coiled up to a roll of used tissue 32.

[0067] In the next dispensing cycle, when the first transport arrangement 41 is activated and provides tissue web 30 through the front slot 21 of the dispensing opening 20, the former part 33a of the tissue portion facing the user U, which has just been used, becomes the part 33b of the tissue portion facing the wall. In this way, the part 33a of the tissue portion 33 facing the user U is usually freshly dispensed from the unused tissue 31 through the front slot 21 of the dispensing opening 20 via the first transport arrangement 41. Once this part 33a of the tissue portion 33 has been used and the part 33b of the tissue portion 33b facing the wall has been retracted through the back slot 22 of the dispensing opening 20 by the second transport arrangement 42, the former user facing part 33a of the tissue portion 33 becomes the new wall facing part of the tissue portion 33b.

[0068] The dispenser 1 further comprises a detection arrangement 100 with a sensor unit 120 comprising a first sensor 101 and a second sensor 102 for detecting a user change. Preferably, the detection arrangement can comprise a third sensor 103 and possibly a fourth sensor and possibly further sensor(s). Further, a control unit 50 is provided, which is adapted to activate the second transport arrangement 42 when a user change is detected. Further preferably, the control unit 50 is also adapted to activate the first transport arrangement 41 when a user change is detected.

[0069] Figures 3, 4, and 5 show dispensers 1 with different detection arrangements 100 having at least a first

and a second sensor 101, 102, for detecting a user change. For example, the detection arrangement 100 in the left-hand dispenser 1 in figure 3 is arranged at the intermediate part 14 of the housing 10 of the dispenser 1 and adapted to detect movements of the hands H of a user U and the resulting movements of the portion 33 of tissue web 30 protruding from the dispensing opening 20. On the right-hand side of figure 3, the detection arrangement 100 of the dispenser 1 is adapted to detect the proximity of a user U or in his or her hand H in front of the sensor 1.

[0070] The left-hand dispenser 1 in figure 4 has a detection arrangement 100 comprising a first sensor 101 in the form of a passive infrared sensor for detecting the proximity of a user's U and H. In the middle of figure 4, a dispenser 1 is depicted comprising a second sensor 102 in the form of a capacitive sensor, which is also adapted to detect the presence of a user's U hands H. On the right-hand side of figure 4, a dispenser 1 is depicted with a detection arrangement 100 having a third sensor 103 in the form of a TOF sensor adapted for detecting a user's U presence, as well as his or her arrival and/or departure to or from the dispenser 1.

[0071] Figure 5 shows a dispenser 1 with different forms of the portions 33 of tissue web 30 protruding from the dispensing opening 20 during use. On the left-hand side of figure 5 the portion 33 protruding from the dispensing opening 20 of the dispenser 1 is small. In the second depiction of the dispenser 1 in figure 5 the first transport arrangement 42 has been activated by pulling the tissue and the portion 33 protruding from the dispensing opening 20 has increased and clearly shows a user facing part 33a and a wall facing part 33b. In the third depiction of the dispenser 1 in figure 5, the loop of the portion 33 of tissue web is hanging freely from the dispensing opening 20. The right-hand side depiction of the dispenser 1 in figure 5 shows a situation similar to the second depiction of the dispenser 1 in figure 5, whether loop of the portion 33 of the tissue web is tilted towards the right-hand side, which means in the direction towards the user U. In particular, when a user U uses a dispenser 1, he would draw the loop of the portion 33 of tissue web, in particular the part 33a towards him or her, leading to a situation as depicted in the second and fourth depiction of the dispenser 1 in figure 5. For the detection of the movement of the tissue, a sensor can be deployed, for example, detecting the varying distance between the user facing part 33a of the portion 33 protruding from the dispensing opening 20 and the intermediate portion 14 of the housing, as indicated in the second and third depiction of the dispenser 1 in figure 5. Alternatively or additionally, the detection arrangement 100 may comprise a sensor 104 depicted on the right-hand side in figure 5, adapted to detect the position of the wall facing part 33b of the tissue portion 33 protruding from the dispensing opening.

[0072] The individual sensors and detection principles shown herein are preferably combined in a detection ar-

rangement and/or in a sensor unit 120 having at least a first and a second sensor 101, 102, which together produce a combination of sensor signals based on which a change user can be detected.

[0073] Figure 6 shows a detailed of a section of an example of the dispenser 1 with a roll 41a of a first transport arrangement 41 and a front slot 21 of a dispensing opening 20. The front face 12 of the housing cover 10 is positioned a first sensor 101 of a detection arrangement 100. In figure 6, two different positions of the user facing part 33a of the tissue web is shown. 33a' schematically shows the position when a user pulls the user facing part 33a of the tissue web. 33a" indicates a situation where the loop of tissue web can hang freely and the front facing part 33a" hangs downward through the front such 21 of the dispensing opening 20.

[0074] Figure 7 shows three dispenses 1 with different positions of sensors 101 having different detection fields 110 oriented in different directions. On the left-hand side, the sensor 101 is positioned at a lower end of the intermediate housing part 14 and has a detection field 110 directed to the lower end of the user facing part 33a of the portion 33 of tissue web protruding from the dispensing opening 20. In the middle of figure 7, the sensor 101 is positioned at an upper end of the intermediate housing part 14 and has a detection field 110 directed to the inner side of the loop of the tissue portion 33. On the right side of figure 7, the sensor 101 is located at a lower part of the front face 12 of the housing 10 and has a detection field 110 directed towards a likely position of a user's U hands H during use of the dispenser 1.

[0075] Figure 8 shows a dispenser 1 with a sensor having a similar detection field 110 as on the right-hand side of figure 7 in a situation where a dispenser 1 is wall-mounted over a washbasin 2.

[0076] Figure 9 shows it is one with a detection arrangement having at least one sensor with a detection field 110 in a substantially horizontal direction towards a user U.

[0077] Figure 10a shows a dispenser 1 having a detection arrangement with at least one sensor having a detection field 110 in the direction of a user U. Figure 10b shows a similar situation as figure 8 but with a queue of three users U, i.e. a high-frequency situation.

[0078] Figure 11 shows a dispenser 1 with a detection arrangement having at least one sensor with a detection field 110 directed towards the likely position of the hands H of a user U during use of the dispenser 1.

[0079] Figure 12 shows a dispenser 1 similar to the dispenser depicted in figure 11 in a top view.

[0080] Figure 13 shows a dispenser 1 similar to the dispenser depicted in figure 11. In figure 13, additional washroom components are shown, which are common in practice and often pose challenges to the correct detection of a user change, in particular a washbasin 2 with metallic surface, ceiling mounted elements 3 like heat radiators, light bulbs, or heaters and underfloor heating 4.

[0081] Figure 14 shows an example of a blocking ele-

ment 210 of a second transport arrangement 42 and a release element 220. The blocking element 210 is in the form of a time controlled, mechanical blocking element having a spring 211 and a pneumatic component 212 controlled by a time controlled valve 215.

[0082] When the first transport arrangement 41 is activated, the blocking element 210 is moved against the force of spring 211 into its blocking position, where the pneumatic element 212 is brought against the wall 213 having a hole 214. The pneumatic element 212 is sucked there against and will be released only after a certain amount of time, which is defined by the time controlled valve 215. For example, the certain amount of time, after which the pneumatic element 212 will be released, can be changed by adjusting or exchanging the time controlled valve 215.

[0083] On the other side of the wall 213, the opening 214 it is closed by a closure element 222 connected to a release valve 221 in the form of a solenoid valve. This release element 220 is adapted to release the blocking element 210 by moving the closure element 222 away from the hole 214. In this way, the pneumatic element 212 relaxes prematurely, i.e. before the determined time of the time controlled valve 215 of the blocking element 210 is over.

[0084] Once the pneumatic element 212 is released (either after a certain time via the time controlled valve 215 or prematurely via the release valve 221), the blocking element 210 moves back into its unblocked position shown on the left-hand side in figure 14 via the force of spring 211. The detail on the right-hand side on figure 14 shows the blocking element 210 in its blocking position.

[0085] Figures 15 and 16 show examples of schematic setups of a detection arrangement 100 and a control unit 50. In principle, a retrofit kit 300 as described herein can comprise or consist of such a detection arrangement and a control unit. For example, in figure 15, a first printed circuit board 51 as well as a second and third printed circuit board 52 and 53 are provided. The first printed circuit board 51 is the main board comprising the CPU and the batteries and is connected via for spring connectors 54 to the third printed circuit board 53 the which the release valve 221 of the release element 220 and a switch, preferably a magnetic switch 230 are connected to activate the release element. Further, the first printed circuit board 51 is connected to a second printed circuit board 52 housing a sensor 101, for example a time of flight sensor, and having a detection field 110.

[0086] Figure 16 shows an example, where a first sensor 101, for example a time of flight (TOF) sensor having a detection field 110, a second sensor 102, for example an infrared sensor having a detection field 110, and a third sensor 103, for example an acceleration sensor, are all located on one single printed circuit board 51 together with the control unit 50. In this case, on the main printed circuit board also the CPU and the battery are positioned. H having a detection field 110. The release valve 221 of the release element is connected to this

single printed circuit board 51.

[0087] Figure 17 shows a further example of a printed circuit board with a first sensor, for example a time of flight sensor 101 with a detection field 110, a second sensor 102, for example in the form of an infrared sensor with a detection field 110 a third sensor 103 in the form of an accelerometer.

[0088] Figure 18 shows a schematic flow diagram of an example activation of the second transport arrangement. On the right-hand side, the steps related to the blocking element 210 are shown, on the left-hand side the steps related to the detection arrangement 100 are shown. Step 401 depicts the start, which can be the activation of the first transport arrangement. This moves the blocking elements 210 in the blocking position and thereby switches the switch 230. This leads to the raising of the detection arrangement 100 from energy-saving sleeping mode to an active mode in step 403. In the following steps, the sensors of the detection arrangement 100 are detecting whether the user change takes place or not. Firstly, in step 404 it is detected whether a user is present in front of the dispenser. In step 408 the value is stored in case a user is present in front of the sensor. In step 406 it is determined whether the user moves away from the sensor. This is done as long as the user does not move away. As soon as the user does move away, the release element is activated in step 407 and the blocking element 210 is released. Subsequently, in step 408, the detection arrangement goes back into energy-saving sleeping mode.

[0089] Further, after step 403 and parallel to step 404, a timer countdown is started in step 409, wherein in step 410 a time value can be set for this timer countdown. This timer countdown preferably corresponds to the predetermined time of the time controlled locking element 210. Step 411 checks whether the timer has counted down to zero. Once the timer is counted down to zero, the detection arrangement 100 is also put into energy-saving sleeping mode again, possibly without activating the release element in step 407, in case the timer has counted down to zero before a user change has been detected in steps 404, 406 and 408.

[0090] Figure 19 shows an example of two different sensor outputs over time. For the reliability and accuracy of the detection of a user change it is advantageous when the sensor output gives a clear indication, of an event to be detected. In the left-hand example of figure 19, the sensor signal indicates the use of the dispenser when the sensor output is larger than a threshold for certain period of time. On the right-hand side of figure 19, a use is detected when the sensor output, for example resembling a proximity of a user, is below a certain threshold for certain period of time. Sensors are preferred, which produce a reliable sensor signal allowing to indicate an event in a very short amount of time, i.e. having a short response time.

[0091] Figures 20 and 21 show examples on how sensor signals can be interpreted for further assessment, in

particular in order to have the control unit act upon detected events. In Figure 20, the line S shows the sensor signal indicating the end of usage, and line I shows the interpretation thereof that the user is out of range. Figure 21 shows with S1 a peak in the sensor signal indicating that a new tissue portion is released and a second peak S2 that the tissue portion is swinging. The vertical portion in dashed line I shows the interpretation of the end of usage.

[0092] Figure 22 and 23, finally, show schematic flow diagrams of the following methods.

[0093] Figure 22 shows a method 1000 for provision of portions of a tissue web, the method comprising transporting 1001 unused tissue and transporting used tissue such that a tissue portion located between a first transport arrangement and a second transport arrangement protrudes through a dispensing opening in a housing of a dispenser, detecting 1002 a user change; activating 1003 the second transport arrangement when a user change is detected.

[0094] The method 2000 for upgrading a dispenser for provision of portions of a tissue web, depicted in Figure 23 comprises installing 2001 a retrofit kit 300 in a dispenser for provision of portions of a tissue web, the dispenser comprising a first transport arrangement for unused tissue and a second transport arrangement for used tissue and a housing with a dispensing opening through which a tissue portion located between the first transport arrangement and the second transport arrangement protrudes.

LIST OF REFERENCE SIGNS

[0095]

1	dispenser
2	washbasin
3	ceiling mounted elements
4	underfloor heating
10	housing
11	openable housing cover
12	front face
13	back part of housing
14	intermediate part of housing
20	dispensing opening
21	front slot
22	back slot
30	tissue web
31	unused tissue
32	used tissue
33	tissue portion protruding through dispensing opening
33a	part of tissue portion facing the user
33b	part of tissue portion facing the wall
41	first transport arrangement
41a	roll of first transport arrangement
42	second transport arrangement
50	control unit

51	first printed circuit board	
52	second printed circuit board	
53	third printed circuit board	
54	spring connectors	
100	detection arrangement	5
120	sensor unit	
101	first sensor	
102	second sensor	
103	third sensor	
104	fourth sensor	10
110	detection field	
210	blocking element	
211	spring	
212	pneumatic element	
213	wall	15
214	hole	
215	time controlled valve	
220	release element	
221	release valve	
222	closure element	20
230	switch	
300	retrofit kit	
401	start	
402	switching of switch	
403	raising the detection arrangement from the energy saving sleeping mode to an active mode	25
404	detecting presence of user in front of dispenser	
405	storing the value for presence of user in front of dispenser	
406	detecting whether the user moves away from the sensor	30
407	activation of release element	
408	detection arrangement goes back to energy saving sleeping mode	
409	starting timer countdown	35
410	setting time value	
411	checking whether the timer has counted down to zero	
1000	method for dispensing provision of portions of a tissue web	40
1001	transporting unused and used tissue such that a tissue portion protrudes through a dispensing opening	
1002	detecting a user change	
1003	activating the second transport arrangement	45
2000	method for upgrading a dispenser for provision of portions of a tissue web	
2001	installing a retrofit kit in a dispenser	
U	user	50

Claims

1. A dispenser (1) for provision of portions of a tissue web (30), comprising
 - a first transport arrangement (41) for unused tissue (31) and a second transport arrangement

(42) for used tissue (32),

- a housing (10) with a dispensing opening (20) through which a tissue portion (33) located between the first transport arrangement (41) and the second transport arrangement (42) protrudes,

- a detection arrangement (100) comprising at least one sensor unit (120) for detecting a user change,

- a control unit (50) adapted to activate the second transport arrangement (42) when a user change is detected,

- **characterized in that** the detection arrangement (100) is in an energy-saving sleeping mode by default and is adapted to raise to an active mode upon activation of the first transport arrangement (41),

- wherein the at least one sensor unit (120) comprises a first sensor (101) and a second sensor (102), and preferably a third sensor (103) for detecting a user change;

- wherein two of said first, second and/or third sensors (101, 102, 103) are an infrared sensor and an acceleration sensor, said acceleration sensor continuously detecting whether a user pulls the tissue or not and switching the infrared sensor from an inactive, energy-saving sleeping mode, to an active mode, if it is detected that a user pulls a tissue.

2. The dispenser (1) according to at least one of the preceding claims, wherein the control unit (50) is adapted to activate the first transport arrangement (41) when a user change is detected.

3. The dispenser (1) according to at least one of the preceding claims, wherein

- the first sensor (101) and/or the second sensor (102) and/or the third sensor (103) have the same or different detection principles, and/or

- the first sensor (101) and/or the second sensor (102) and/or the third sensor (103) have the same or different detection fields, and/or

- at least one of the sensors (101, 102, 103) and/or the sensor unit (120) has a detection field in the direction of a user (U), and/or

- at least one of the sensors (101, 102, 103) and/or the sensor unit (120) has a detection field in the direction of the tissue web (30), and/or

- at least one of the sensors (101, 102, 103) and/or the sensor unit (120) is positioned on a front face of the dispenser (1), and/or at least one of the sensors (101, 102, 103) is positioned adjacent the dispensing opening (20), and/or at least one of the sensors (101, 102, 103) and/or the sensor unit (120) is positioned on an intermediate part (14) of the dispenser housing (10).

4. The dispenser (1) according to at least one of the preceding claims, wherein the first sensor (101) and/or the second sensor (102) and/or the third sensor (103) is chosen from the following group of sensors, comprising or consisting of:
- acceleration sensor,
 - motion sensor,
 - thermal sensor,
 - infrared sensor,
 - radiation sensor, in particular electromagnetic radiation sensor,
 - optic sensor,
 - time-of-flight sensor,
 - capacitive sensor,
 - an image sensor,
 - reflective sensor,
 - pyroelectric (passive) infrared sensor,
 - thermopile sensor.
5. The dispenser (1) according to at least one of the preceding claims, wherein at least two of the first sensor (101) and/or the second sensor (102) and/or the third sensor (103) are arranged on a single circuit board.
6. The dispenser (1) according to at least one of the preceding claims, wherein the second transport arrangement (42) comprises a blocking element (210), wherein the activation of the second transport arrangement (41) via control unit (50) comprises the release of the blocking element.
7. The dispenser (1) according to at least one of the preceding claims,
- wherein the blocking element (210) is a time controlled, preferably mechanical, blocking element, and/or
 - wherein the second transport arrangement (42) comprises a release element (220) adapted to release the blocking element (210).
8. The dispenser (1) according to at least one of the preceding claims, wherein the release element (220) comprises a valve (221), in particular an electric valve and/or a solenoid valve, and/or a drive, in particular an electric drive.
9. The dispenser (1) according to at least one of the preceding claims, wherein
- the first transport arrangement (41) comprises a manual transport mechanism and/or an automatic transport mechanism, and/or
 - the second transport arrangement (42) comprises a manual transport mechanism and/or an automatic transport mechanism.
10. The dispenser (1) according to at least one of the preceding claims,
- wherein the control unit (50) is adapted to activate the second transport arrangement (42) when a repeated activation of the first transport arrangement (41) by a single user is detected, and/or
 - wherein the control unit (50) is adapted to activate the second transport arrangement (42) when a departure speed of a user is detected that is above a threshold value.
11. A retrofit kit (300) for a dispenser (1) according to at least one of the preceding claims, the retrofit kit comprising
- a detection arrangement (100) comprising at least one sensor unit (120), preferably comprising a first sensor (101) and a second sensor (102), for detecting a user change
 - a control unit (50) adapted to activate a second transport arrangement (42) of the dispenser when a user change is detected,
 - **characterized in that** the detection arrangement (100) is in an energy-saving sleeping mode by default and is adapted to raise to an active mode upon activation of the first transport arrangement (42),
 - wherein the at least one sensor unit (120) comprises a first sensor (101) and a second sensor (102), and preferably a third sensor (103) for detecting a user change;
 - wherein two of said first, second and/or third sensors (101, 102, 103) are an infrared sensor and an acceleration sensor, said acceleration sensor continuously detecting whether a user pulls the tissue or not and switching the infrared sensor from an inactive, energy-saving sleeping mode, to an active mode, if it is detected that a user pulls a tissue.
12. The retrofit kit (300) according to the preceding claim, comprising
- a release element (220) adapted to release a blocking element (210) of the second transport arrangement (42) of the dispenser (1).
13. A method (1000) for provision of portions of a tissue web (20), the method comprising
- transporting (1001) unused tissue (21) and transporting used tissue (32) such that a tissue portion (33) located between a first transport arrangement (41) and a second transport arrangement (42) protrudes through a dispensing opening (20) in a housing (10) of a dispenser (1),

- detecting (1002) a user change;
- activating (1003) the second transport arrangement (42) when a user change is detected,
- raising the detection arrangement (100) from a default energy-saving sleeping mode to an active mode upon activation of the first transport arrangement (41),
- wherein the at least one sensor unit (120) comprises a first sensor (101) and a second sensor (102), and preferably a third sensor (103) for detecting a user change;
- wherein two of said first, second and/or third sensors (101, 102, 103) are an infrared sensor and an acceleration sensor, said acceleration sensor continuously detecting whether a user pulls the tissue or not and switching the infrared sensor from an inactive, energy-saving sleeping mode, to an active mode, if it is detected that a user pulls a tissue.

14. A method (2000) for upgrading a dispenser (1) for provision of portions of a tissue web, the method comprising

- installing (2001) a retrofit kit according to at least one of the preceding claims 12-13 in a dispenser for provision of portions of a tissue web (30),
- the dispenser comprising a first transport arrangement (41) for unused tissue (31) and a second transport arrangement (42) for used tissue (32) and a housing (10) with a dispensing opening (20) through which a tissue portion (33) located between the first transport arrangement (41) and the second transport arrangement (42) protrudes.

Patentansprüche

1. Spender (1) zur Bereitstellung von Abschnitten einer Tuchbahn (30), umfassend

- eine erste Transportanordnung (41) für unbenutztes Tuch (31) und eine zweite Transportanordnung (42) für benutztes Tuch (32),
- ein Gehäuse (10) mit einer Ausgabeöffnung (20), durch die ein zwischen der ersten Transportanordnung (41) und der zweiten Transportanordnung (42) angeordneter Tuchabschnitt (33) herausragt,
- eine Detektionsanordnung (100), umfassend mindestens eine Sensoreinheit (120) zur Detektion einer Benutzeränderung,
- eine Steuereinheit (50), die dazu ausgebildet ist, die zweite Transportanordnung (42) zu aktivieren, wenn eine Benutzeränderung detektiert wird,

- **dadurch gekennzeichnet, dass** sich die Detektionsanordnung (100) standardmäßig in einem energiesparenden Schlafmodus befindet und so ausgebildet ist, dass sie bei Aktivierung der ersten Transportanordnung (41) in einen aktiven Modus übergeht,
- wobei die mindestens eine Sensoreinheit (120) einen ersten Sensor (101) und einen zweiten Sensor (102) und vorzugsweise einen dritten Sensor (103) zur Detektion einer Benutzeränderung umfasst;
- wobei zwei der ersten, zweiten und/oder dritten Sensoren (101, 102, 103) ein Infrarotsensor und ein Beschleunigungssensor sind, wobei der Beschleunigungssensor kontinuierlich detektiert, ob ein Benutzer an dem Tuch zieht oder nicht, und den Infrarotsensor von einem inaktiven, energiesparenden Schlafmodus in einen aktiven Modus schaltet, wenn detektiert wird, dass ein Benutzer an einem Tuch zieht.

2. Spender (1) nach mindestens einem der vorhergehenden Ansprüche, wobei die Steuereinheit (50) ausgebildet ist, die erste Transportanordnung (41) zu aktivieren, wenn eine Benutzeränderung detektiert wird.

3. Spender (1) nach mindestens einem der vorhergehenden Ansprüche, wobei

- der erste Sensor (101) und/oder der zweite Sensor (102) und/oder der dritte Sensor (103) die gleichen oder unterschiedliche Detektionsprinzipien haben, und/oder
- der erste Sensor (101) und/oder der zweite Sensor (102) und/oder der dritte Sensor (103) die gleichen oder unterschiedliche Detektionsfelder haben, und/oder
- mindestens einer der Sensoren (101, 102, 103) und/oder die Sensoreinheit (120) ein Detektionsfeld in Richtung eines Benutzers (U) aufweist, und/oder
- mindestens einer der Sensoren (101, 102, 103) und/oder die Sensoreinheit (120) ein Detektionsfeld in Richtung der Tuchbahn (30) aufweist, und/oder
- mindestens einer der Sensoren (101, 102, 103) und/oder die Sensoreinheit (120) an einer Vorderseite des Spenders (1) positioniert ist, und/oder mindestens einer der Sensoren (101, 102, 103) neben der Ausgabeöffnung (20) positioniert ist, und/oder mindestens einer der Sensoren (101, 102, 103) und/oder die Sensoreinheit (120) an einem Zwischenteil (14) des Spendergehäuses (10) positioniert ist.

4. Spender (1) nach mindestens einem der vorhergehenden Ansprüche, wobei der erste Sensor (101)

- und/oder der zweite Sensor (102) und/oder der dritte Sensor (103) ausgewählt ist aus der folgenden Gruppe von Sensoren, umfassend oder bestehend aus:
- Beschleunigungssensor, 5
 - Bewegungssensor,
 - Wärmesensor,
 - Infrarotsensor,
 - Strahlungssensor, insbesondere elektromagnetischer Strahlungssensor, 10
 - optischer Sensor,
 - Laufzeitsensor,
 - kapazitiver Sensor,
 - ein Bildsensor,
 - Reflexionssensor, 15
 - pyroelektrischer (passiver) Infrarotsensor,
 - Thermosäulen-Sensor.
5. Spender (1) nach mindestens einem der vorhergehenden Ansprüche, wobei mindestens zwei der ersten Sensoren (101) und/oder der zweiten Sensoren (102) und/oder der dritten Sensoren (103) auf einer einzigen Leiterplatte angeordnet sind. 20
6. Spender (1) nach mindestens einem der vorhergehenden Ansprüche, wobei die zweite Transportanordnung (42) ein Sperrelement (210) aufweist, wobei die Aktivierung der zweiten Transportanordnung (41) über die Steuereinheit (50) die Freigabe des Sperrelements umfasst. 25
30
7. Spender (1) nach mindestens einem der vorhergehenden Ansprüche, 35
- wobei das Sperrelement (210) ein zeitgesteuertes, vorzugsweise mechanisches, Sperrelement ist, und/oder
 - wobei die zweite Transportanordnung (42) ein Auslöseelement (220) umfasst, das ausgebildet ist, das Sperrelement (210) zu lösen. 40
8. Spender (1) nach mindestens einem der vorhergehenden Ansprüche, wobei das Auslöseelement (220) ein Ventil (221), insbesondere ein elektrisches Ventil und/oder ein Magnetventil, und/oder einen Antrieb, insbesondere einen elektrischen Antrieb, umfasst. 45
9. Spender (1) nach mindestens einem der vorhergehenden Ansprüche, wobei 50
- die erste Transportanordnung (41) einen manuellen Transportmechanismus und/oder einen automatischen Transportmechanismus umfasst, und/oder 55
 - die zweite Transportanordnung (42) einen manuellen Transportmechanismus und/oder einen automatischen Transportmechanismus um-
- fasst.
10. Spender (1) nach mindestens einem der vorhergehenden Ansprüche, 5
- wobei die Steuereinheit (50) dazu ausgebildet ist, die zweite Transportanordnung (42) zu aktivieren, wenn eine wiederholte Aktivierung der ersten Transportanordnung (41) durch einen einzelnen Benutzer detektiert wird, und/oder
 - wobei die Steuereinheit (50) dazu ausgebildet ist, die zweite Transportanordnung (42) zu aktivieren, wenn eine Weggangsgeschwindigkeit eines Benutzers detektiert wird, die über einem Schwellenwert liegt.
11. Nachrüstatz (300) für einen Spender (1) nach mindestens einem der vorhergehenden Ansprüche, wobei der Nachrüstatz umfasst
- eine Detektionsanordnung (100) mit mindestens einer Sensoreinheit (120), vorzugsweise mit einem ersten Sensor (101) und einem zweiten Sensor (102), zur Detektion einer Benutzeränderung
 - eine Steuereinheit (50), die ausgebildet ist, eine zweite Transportanordnung (42) des Senders zu aktivieren, wenn eine Benutzeränderung detektiert wird,
 - **dadurch gekennzeichnet, dass** sich die Detektionsanordnung (100) standardmäßig in einem energiesparenden Schlafmodus befindet und so angepasst ist, dass sie bei Aktivierung der ersten Transportanordnung (42) in einen aktiven Modus übergeht,
 - wobei die mindestens eine Sensoreinheit (120) einen ersten Sensor (101) und einen zweiten Sensor (102) und vorzugsweise einen dritten Sensor (103) zur Detektion einer Benutzeränderung umfasst;
 - wobei zwei der ersten, zweiten und/oder dritten Sensoren (101, 102, 103) ein Infrarotsensor und ein Beschleunigungssensor sind, wobei der Beschleunigungssensor kontinuierlich detektiert, ob ein Benutzer an dem Tuch zieht oder nicht, und den Infrarotsensor von einem inaktiven, energiesparenden Schlafmodus in einen aktiven Modus schaltet, wenn detektiert wird, dass ein Benutzer an einem Tuch zieht.
12. Nachrüstatz (300) nach dem vorhergehenden Anspruch, umfassend
- ein Auslöseelement (220), das ausgebildet ist, ein Sperrelement (210) der zweiten Transportanordnung (42) des Senders (1) zu lösen.
13. Verfahren (1000) zur Bereitstellung von Abschnitten

einer Tuchbahn (20), das Verfahren umfassend

- Transportieren (1001) von unbenutztem Tuch (21) und Transportieren von benutztem Tuch (32), so dass ein Tuchabschnitt (33), der sich zwischen einer ersten Transportanordnung (41) und einer zweiten Transportanordnung (42) befindet, durch eine Ausgabeöffnung (20) in einem Gehäuse (10) eines Spenders (1) herausragt,
- Detektion (1002) einer Benutzeränderung;
- Aktivieren (1003) der zweiten Transportanordnung (42), wenn eine Benutzeränderung detektiert wird,
- Übergehen der Detektionsanordnung (100) aus einem standardmäßigen energiesparenden Schlafmodus in einen aktiven Modus bei Aktivierung der ersten Transportanordnung (41),
- wobei die mindestens eine Sensoreinheit (120) einen ersten Sensor (101) und einen zweiten Sensor (102) und vorzugsweise einen dritten Sensor (103) zur Detektion einer Benutzeränderung umfasst;
- wobei zwei der ersten, zweiten und/oder dritten Sensoren (101, 102, 103) ein Infrarotsensor und ein Beschleunigungssensor sind, wobei der Beschleunigungssensor kontinuierlich detektiert, ob ein Benutzer an dem Tuch zieht oder nicht, und den Infrarotsensor von einem inaktiven, energiesparenden Schlafmodus in einen aktiven Modus schaltet, wenn detektiert wird, dass ein Benutzer an einem Tuch zieht.

14. Verfahren (2000) zum Nachrüsten eines Spenders (1) zur Bereitstellung von Abschnitten einer Tuchbahn, wobei das Verfahren umfasst

- Einbau (2001) eines Nachrüstsatzes nach mindestens einem der vorhergehenden Ansprüche 12-13 in einen Spender zur Bereitstellung von Abschnitten einer Tuchbahn (30),
- der Spender umfassend eine erste Transportanordnung (41) für unbenutztes Tuch (31) und eine zweite Transportanordnung (42) für benutztes Tuch (32) sowie ein Gehäuse (10) mit einer Ausgabeöffnung (20), durch die ein zwischen der ersten Transportanordnung (41) und der zweiten Transportanordnung (42) befindlicher Tuchabschnitt (33) herausragt.

Revendications

1. Distributeur (1) pour la fourniture de portions d'une bande de tissu (30), comprenant

- un premier agencement de transport (41) pour tissu non utilisé (31) et un deuxième agencement de transport (42) pour tissu utilisé (32),

- un boîtier (10) avec une ouverture de distribution (20) à travers laquelle une portion de tissu (33) située entre le premier agencement de transport (41) et le deuxième agencement de transport (42) fait saillie,
- un agencement de détection (100) comprenant au moins une unité de capteurs (120) pour la détection d'un changement d'utilisateur,
- une unité de commande (50) adaptée pour activer le deuxième agencement de transport (42) lorsqu'un changement d'utilisateur est détecté,
- **caractérisé en ce que** l'agencement de détection (100) est dans un mode de veille à économie d'énergie par défaut et est adapté pour s'élever à un mode actif lors de l'activation du premier agencement de transport (41),
- dans lequel l'au moins une unité de capteurs (120) comprend un premier capteur (101) et un deuxième capteur (102), et de préférence un troisième capteur (103) pour la détection d'un changement d'utilisateur ;
- dans lequel deux desdits premier, deuxième et/ou troisième capteurs (101, 102, 103) sont un capteur infrarouge et un capteur d'accélération, ledit capteur d'accélération détectant en continu si un utilisateur tire sur le tissu ou non et commutant le capteur infrarouge d'un mode de veille à économie d'énergie, inactif à un mode actif, s'il est détecté qu'un utilisateur tire sur un tissu.

2. Distributeur (1) selon au moins l'une des revendications précédentes, dans lequel l'unité de commande (50) est adaptée pour activer le premier agencement de transport (41) lorsqu'un changement d'utilisateur est détecté.

3. Distributeur (1) selon au moins l'une des revendications précédentes, dans lequel

- le premier capteur (101) et/ou le deuxième capteur (102) et/ou le troisième capteur (103) ont les mêmes principes de détection ou des principes de détection différents, et/ou
- le premier capteur (101) et/ou le deuxième capteur (102) et/ou le troisième capteur (103) ont les mêmes champs de détection ou des champs de détection différents, et/ou
- au moins un des capteurs (101, 102, 103) et/ou l'unité de capteurs (120) a un champ de détection dans la direction d'un utilisateur (U), et/ou
- au moins un des capteurs (101, 102, 103) et/ou l'unité de capteurs (120) a un champ de détection dans la direction de la bande de tissu (30), et/ou
- au moins un des capteurs (101, 102, 103) et/ou l'unité de capteurs (120) est positionné sur une face avant du distributeur (1), et/ou au moins un des capteurs (101, 102, 103) est positionné de

- manière adjacente à l'ouverture de distribution (20), et/ou au moins un des capteurs (101, 102, 103) et/ou l'unité de capteurs (120) est positionné sur une partie intermédiaire (14) du boîtier de distributeur (10).
4. Distributeur (1) selon au moins l'une des revendications précédentes, dans lequel le premier capteur (101) et/ou le deuxième capteur (102) et/ou le troisième capteur (103) est choisi dans le groupe de capteurs suivant, comprenant ou constitué par :
- capteur d'accélération,
 - capteur de mouvement,
 - capteur thermique,
 - capteur infrarouge,
 - capteur de rayonnement, en particulier capteur de rayonnement électromagnétique,
 - capteur optique,
 - capteur à temps de vol,
 - capteur capacitif,
 - un capteur d'image,
 - capteur réflectif,
 - capteur infrarouge (passif) pyroélectrique,
 - capteur à thermopile.
5. Distributeur (1) selon au moins l'une des revendications précédentes, dans lequel au moins deux parmi le premier capteur (101) et/ou le deuxième capteur (102) et/ou le troisième capteur (103) sont agencés sur une carte de circuit imprimé unique.
6. Distributeur (1) selon au moins l'une des revendications précédentes, dans lequel le deuxième agencement de transport (42) comprend un élément de blocage (210), dans lequel l'activation du deuxième agencement de transport (41) via l'unité de commande (50) comprend la libération de l'élément de blocage.
7. Distributeur (1) selon au moins l'une des revendications précédentes,
- dans lequel l'élément de blocage (210) est un élément de blocage à commande temporelle, de préférence mécanique, et/ou
 - dans lequel le deuxième agencement de transport (42) comprend un élément de libération (220) adapté pour libérer l'élément de blocage (210).
8. Distributeur (1) selon au moins l'une des revendications précédentes, dans lequel l'élément de libération (220) comprend une soupape (221), en particulier une soupape électrique et/ou une électrovanne, et/ou un entraînement, en particulier un entraînement électrique.
9. Distributeur (1) selon au moins l'une des revendications précédentes, dans lequel
- le premier agencement de transport (41) comprend un mécanisme de transport manuel et/ou un mécanisme de transport automatique, et/ou
 - le deuxième agencement de transport (42) comprend un mécanisme de transport manuel et/ou un mécanisme de transport automatique.
10. Distributeur (1) selon au moins l'une des revendications précédentes,
- dans lequel l'unité de commande (50) est adaptée pour activer le deuxième agencement de transport (42) lorsqu'une activation répétée du premier agencement de transport (41) par un utilisateur unique est détectée, et/ou
 - dans lequel l'unité de commande (50) est adaptée pour activer le deuxième agencement de transport (42) lorsqu'une vitesse de départ d'un utilisateur est détectée qui est supérieure à une valeur seuil.
11. Kit de rattrapage (300) pour un distributeur (1) selon au moins l'une des revendications précédentes, le kit de rattrapage comprenant
- un agencement de détection (100) comprenant au moins une unité de capteurs (120), comprenant de préférence un premier capteur (101) et un deuxième capteur (102), pour la détection d'un changement d'utilisateur
 - une unité de commande (50) adaptée pour activer un deuxième agencement de transport (42) du distributeur lorsqu'un changement d'utilisateur est détecté,
 - **caractérisé en ce que** l'agencement de détection (100) est dans un mode de veille à économie d'énergie par défaut et est adapté pour s'élever à un mode actif lors de l'activation du premier agencement de transport (42),
 - dans lequel l'au moins une unité de capteurs (120) comprend un premier capteur (101) et un deuxième capteur (102), et de préférence un troisième capteur (103) pour la détection d'un changement d'utilisateur ;
 - dans lequel deux desdits premier, deuxième et/ou troisième capteurs (101, 102, 103) sont un capteur infrarouge et un capteur d'accélération, ledit capteur d'accélération détectant en continu si un utilisateur tire sur le tissu ou non et commutant le capteur infrarouge d'un mode de veille à économie d'énergie, inactif à un mode actif, s'il est détecté qu'un utilisateur tire sur un tissu.
12. Kit de rattrapage (300) selon la revendication précédente, comprenant

- un élément de libération (220) adapté pour libérer un élément de blocage (210) du deuxième agencement de transport (42) du distributeur (1).

5

13. Procédé (1000) de fourniture de portions d'une bande de tissu (20), le procédé comprenant

- le transport (1001) de tissu non utilisé (21) et le transport de tissu utilisé (32) de telle sorte qu'une portion de tissu (33) située entre un premier agencement de transport (41) et un deuxième agencement de transport (42) fait saillie à travers une ouverture de distribution (20) dans un boîtier (10) d'un distributeur (1), 10
 - la détection (1002) d'un changement d'utilisateur ; 15
 - l'activation (1003) du deuxième agencement de transport (42) lorsqu'un changement d'utilisateur est détecté, 20
 - l'élévation de l'agencement de détection (100) d'un mode de veille à économie d'énergie par défaut à un mode actif lors de l'activation du premier agencement de transport (41),
 - dans lequel l'au moins une unité de capteurs (120) comprend un premier capteur (101) et un deuxième capteur (102), et de préférence un troisième capteur (103) pour la détection d'un changement d'utilisateur ; 25
 - dans lequel deux desdits premier, deuxième et/ou troisième capteurs (101, 102, 103) sont un capteur infrarouge et un capteur d'accélération, ledit capteur d'accélération détectant en continu si un utilisateur tire sur le tissu ou non et commutant le capteur infrarouge d'un mode de veille à économie d'énergie, inactif à un mode actif, s'il est détecté qu'un utilisateur tire sur un tissu. 30
 35

14. Procédé (2000) de mise à niveau d'un distributeur (1) pour la fourniture de portions d'une bande de tissu, le procédé comprenant 40

- l'installation (2001) d'un kit de rattrapage selon au moins l'une des revendications précédentes 12-13 dans un distributeur pour la fourniture de portions d'une bande de tissu (30), 45
 - le distributeur comprenant un premier agencement de transport (41) pour tissu non utilisé (31) et un deuxième agencement de transport (42) pour tissu utilisé (32) et un boîtier (10) avec une ouverture de distribution (20) à travers laquelle une portion de tissu (33) située entre le premier agencement de transport (41) et le deuxième agencement de transport (42) fait saillie. 50
 55

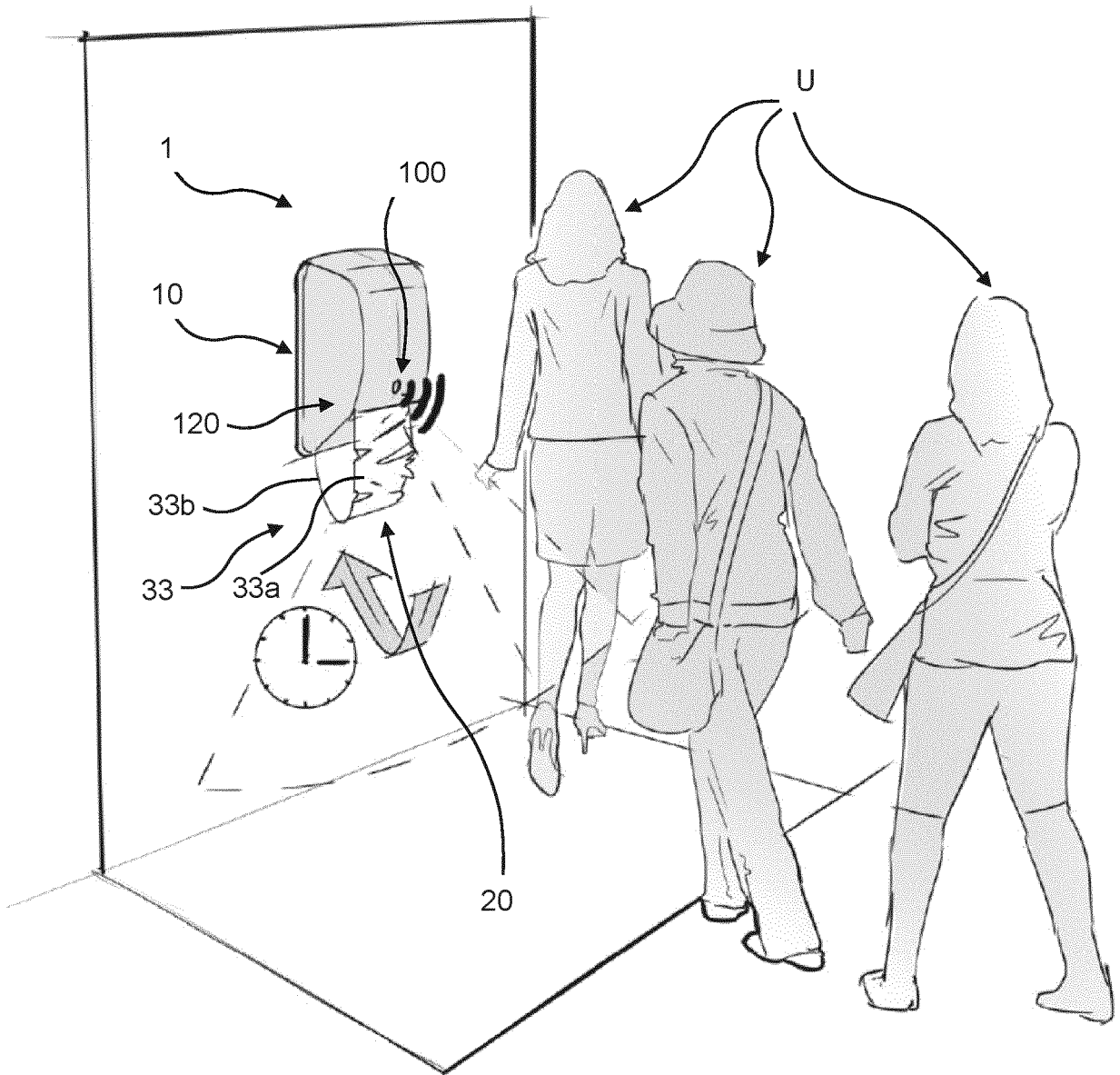

Fig. 1

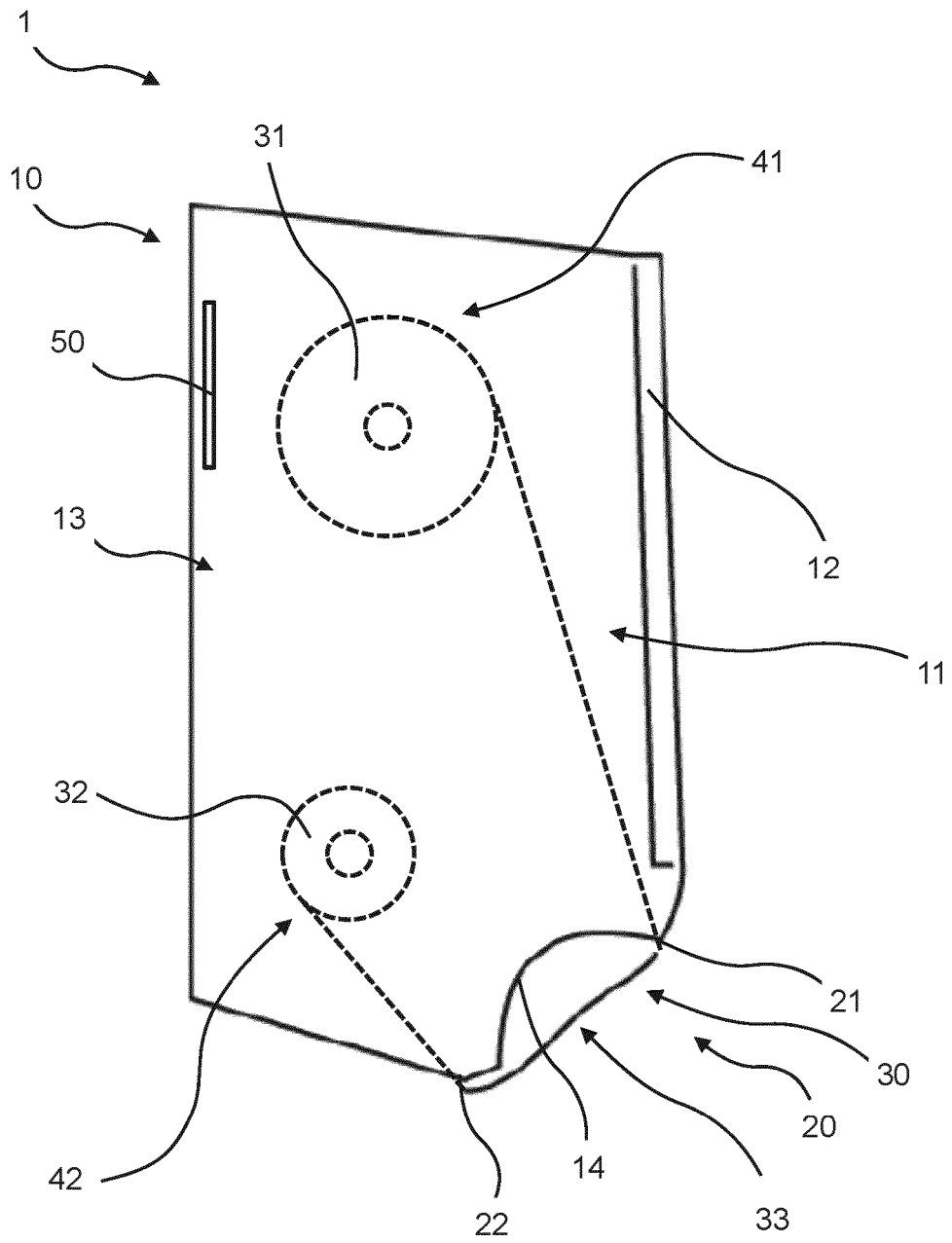

Fig. 2

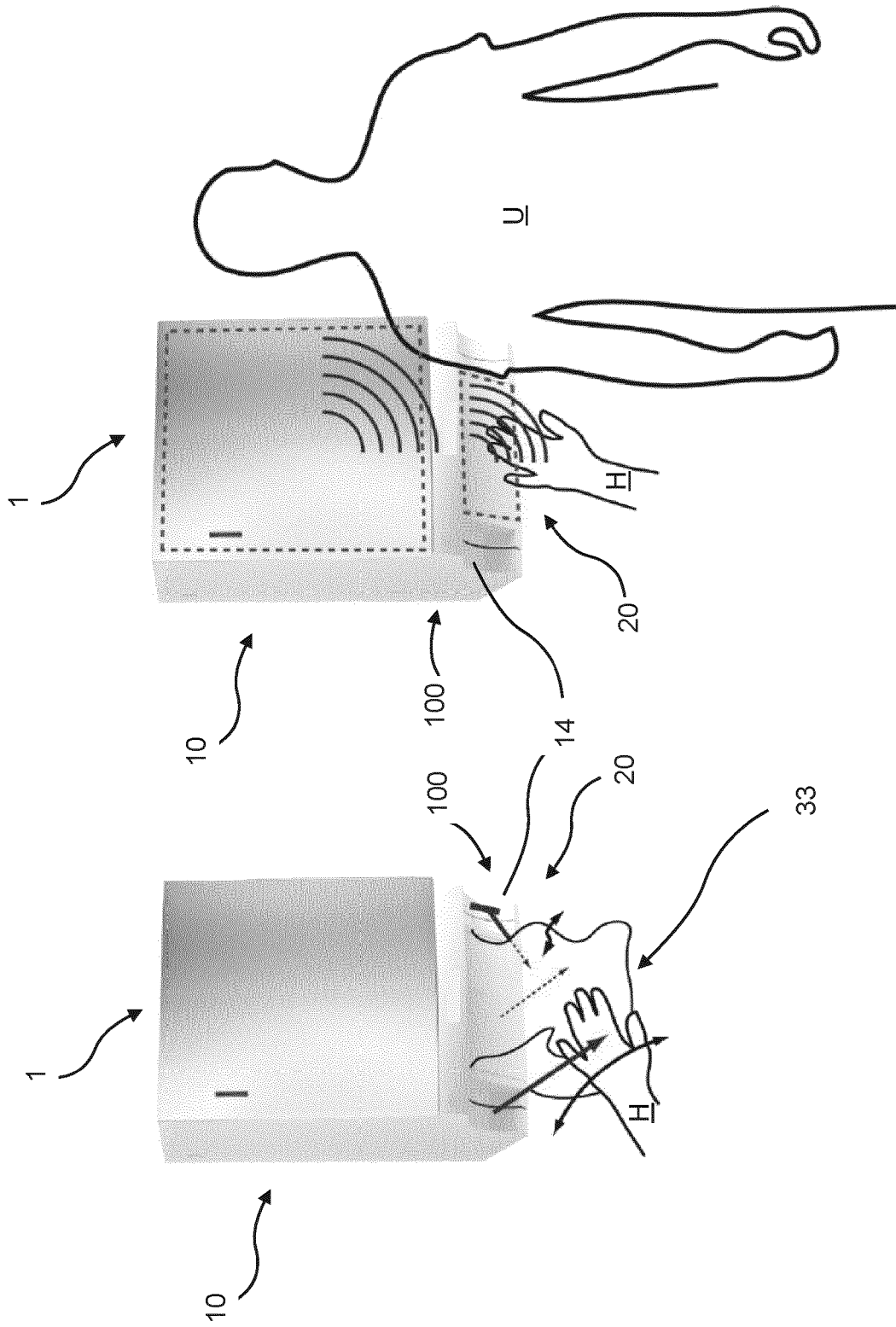

Fig. 3

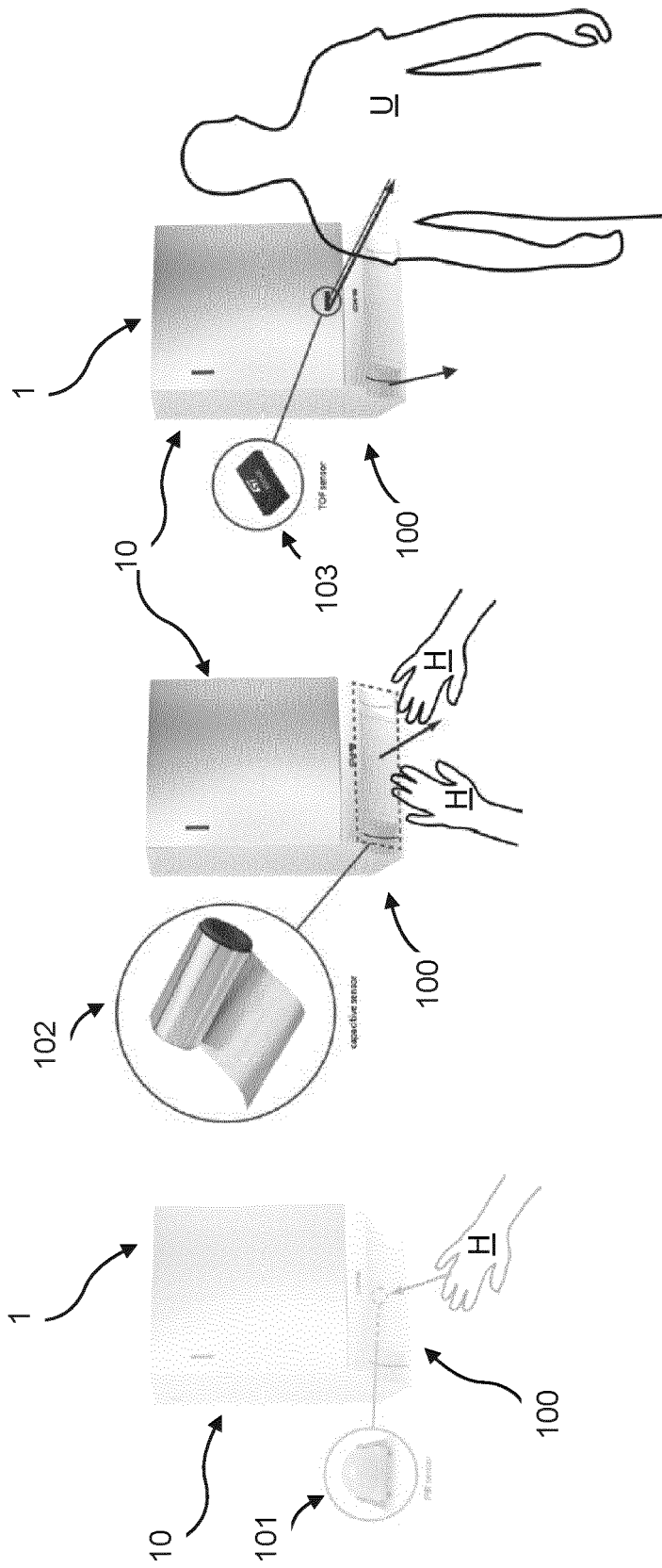

Fig. 4

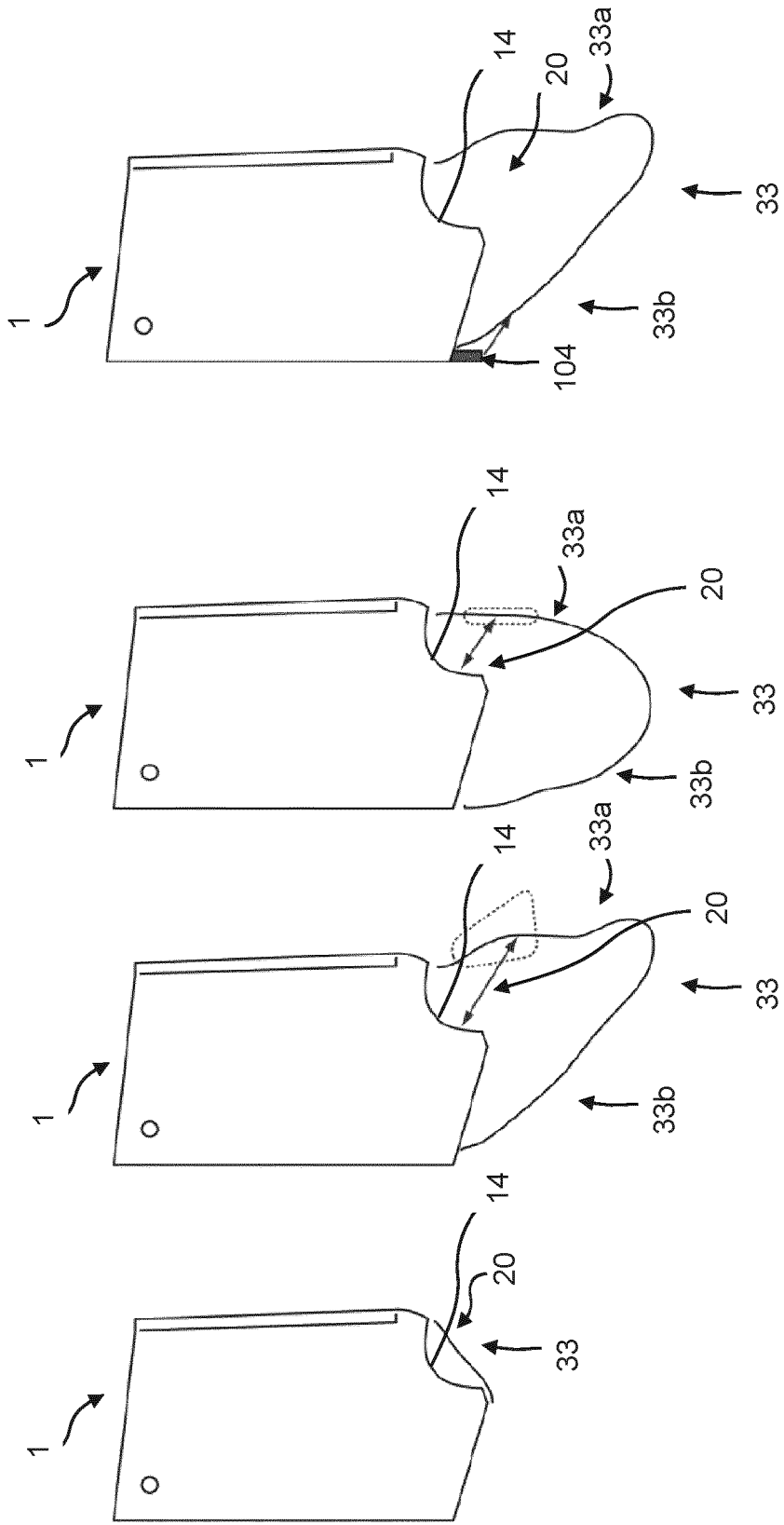
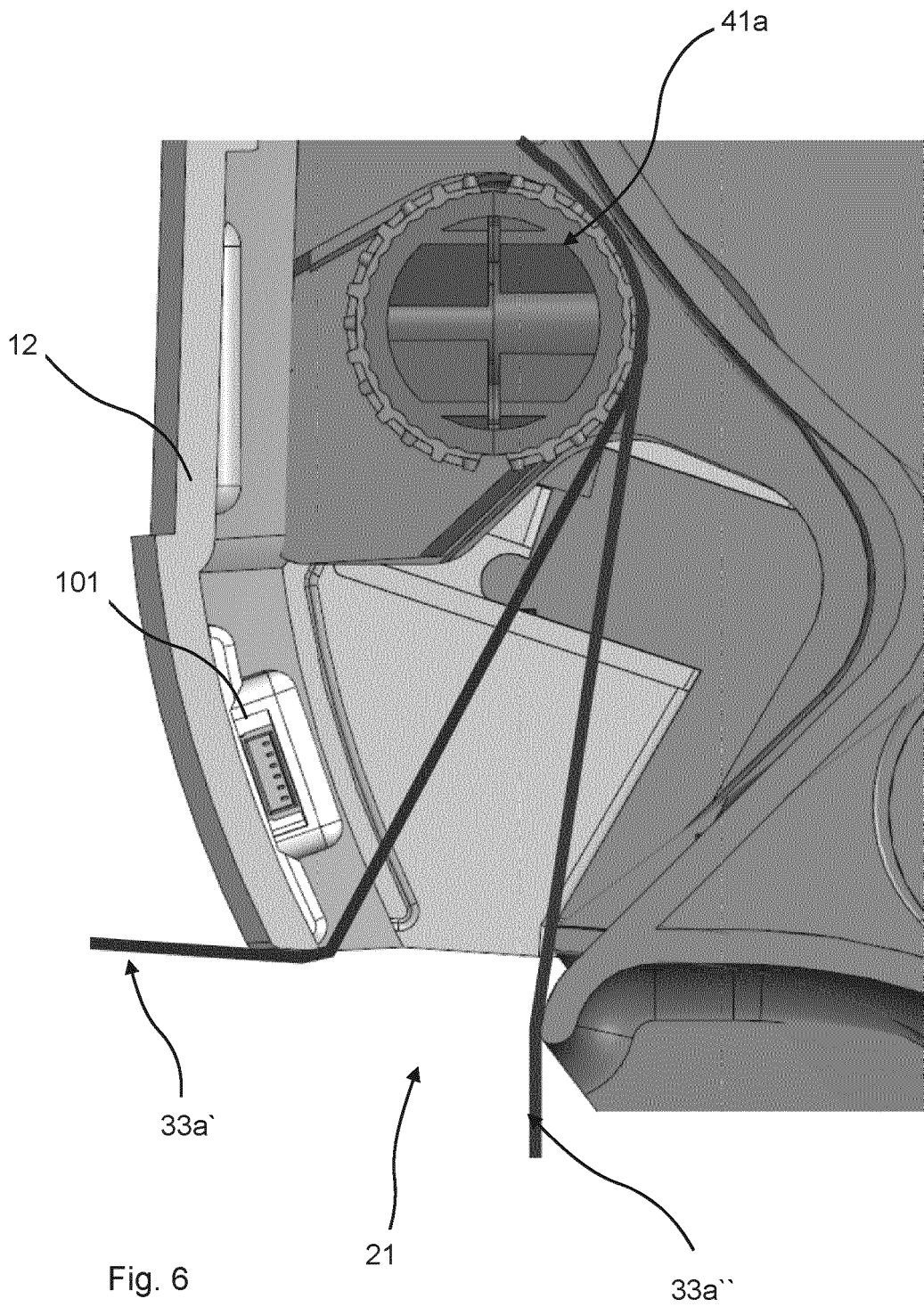

Fig. 5



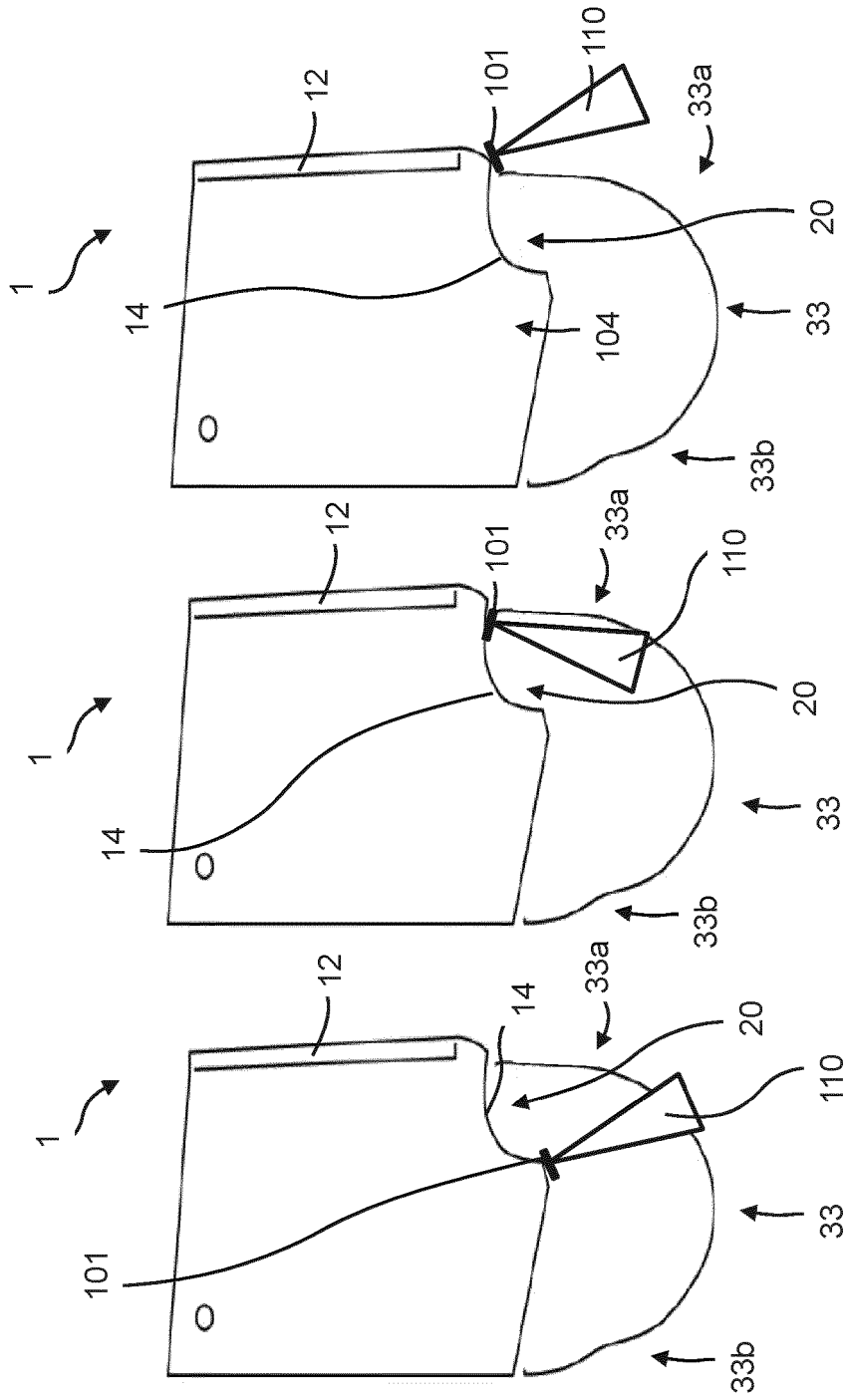

Fig. 7

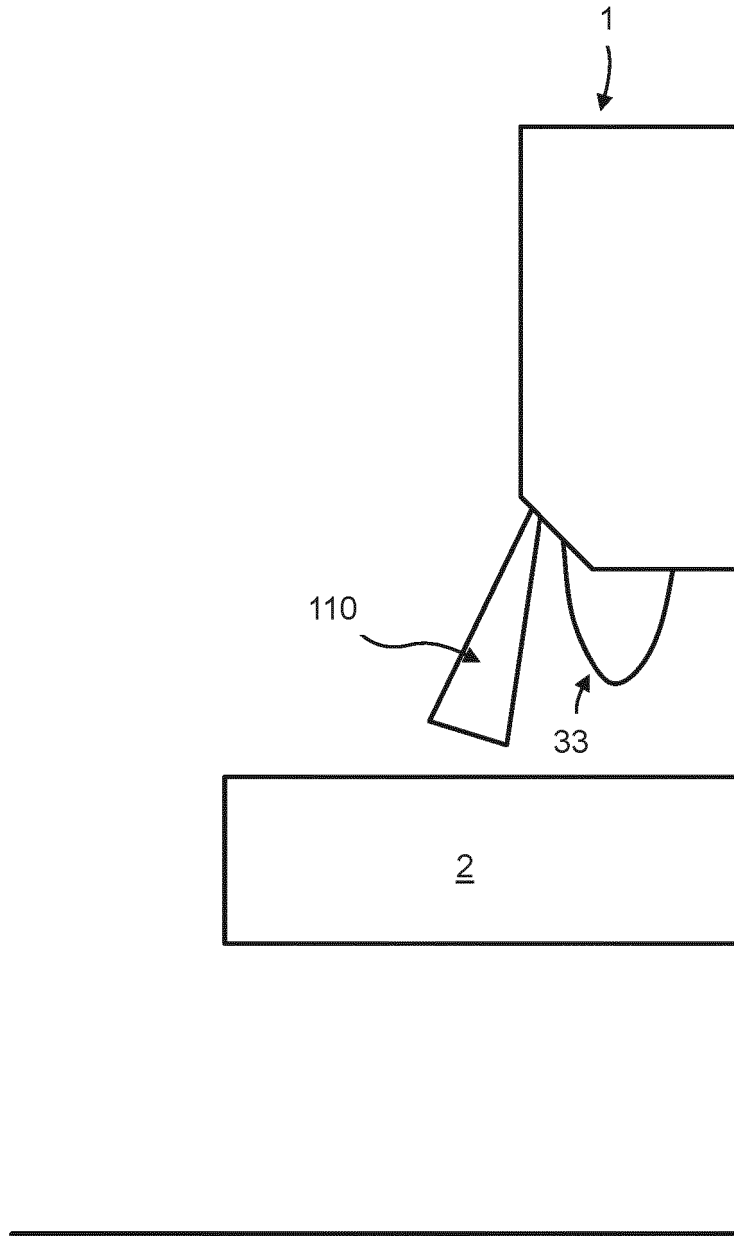

Fig. 8

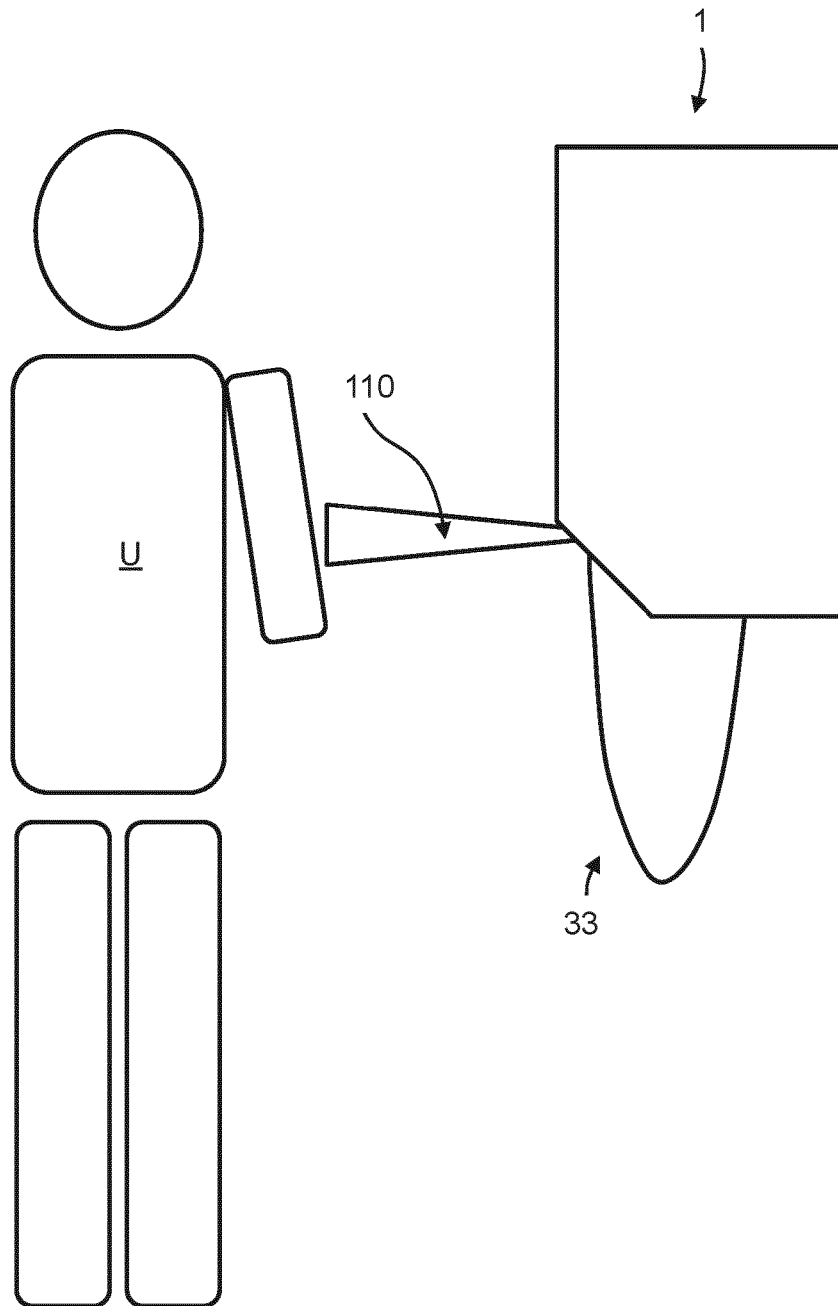

Fig. 9

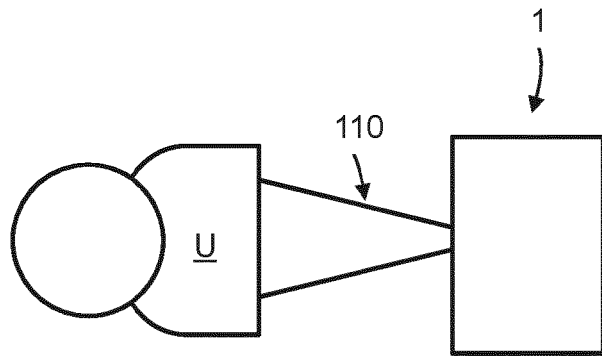

Fig. 10a

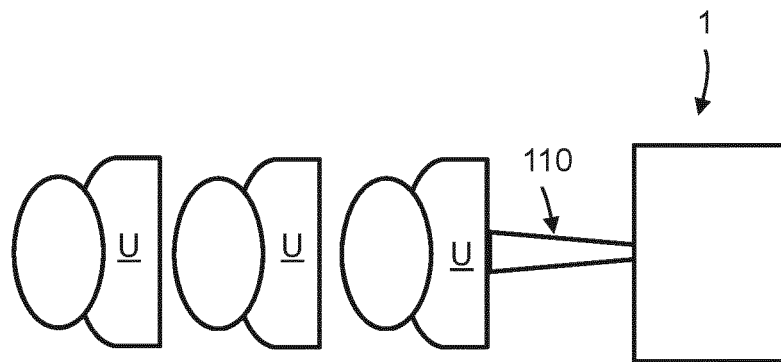

Fig. 10b

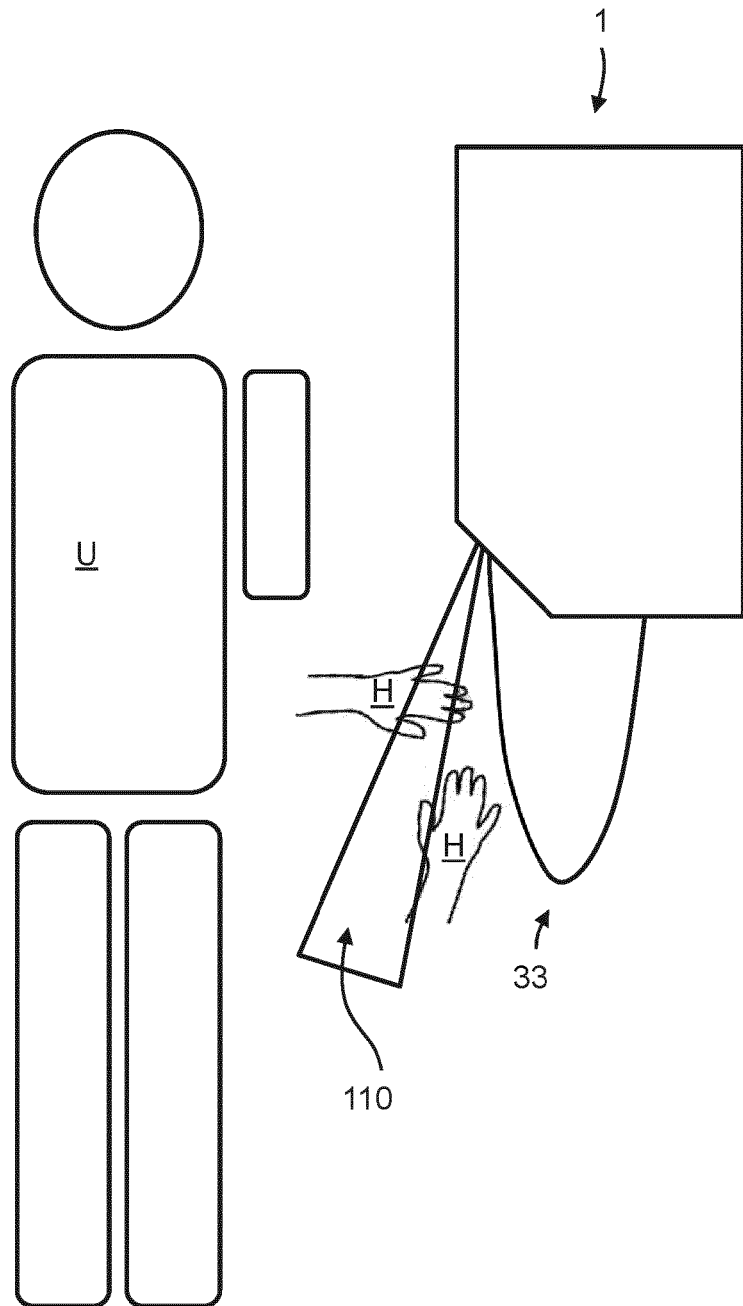

Fig. 11

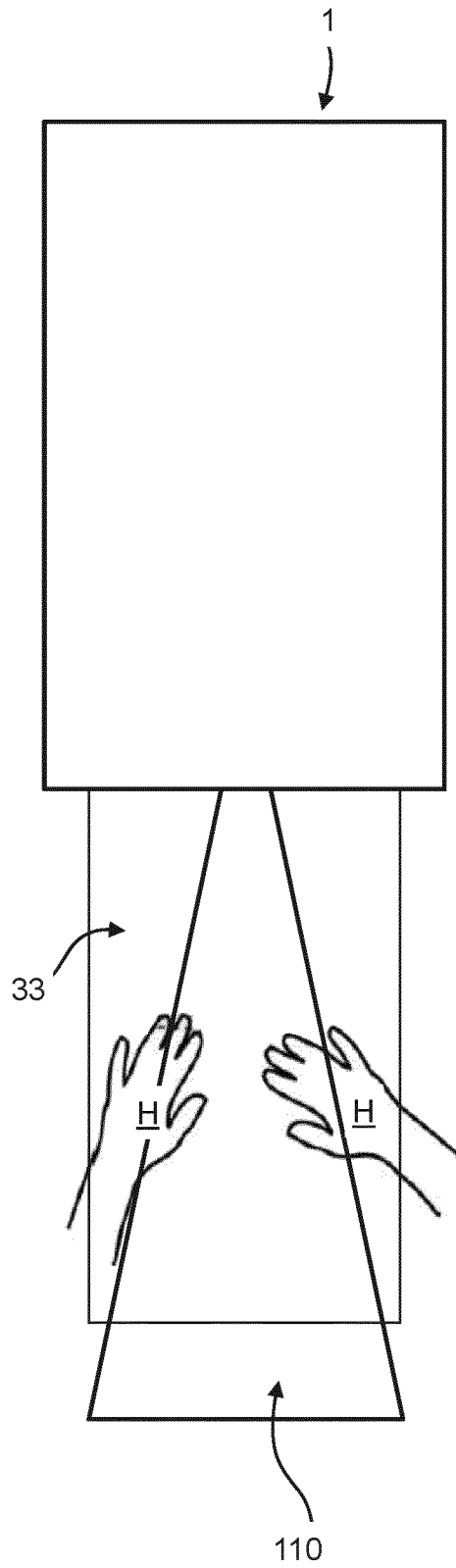

Fig. 12

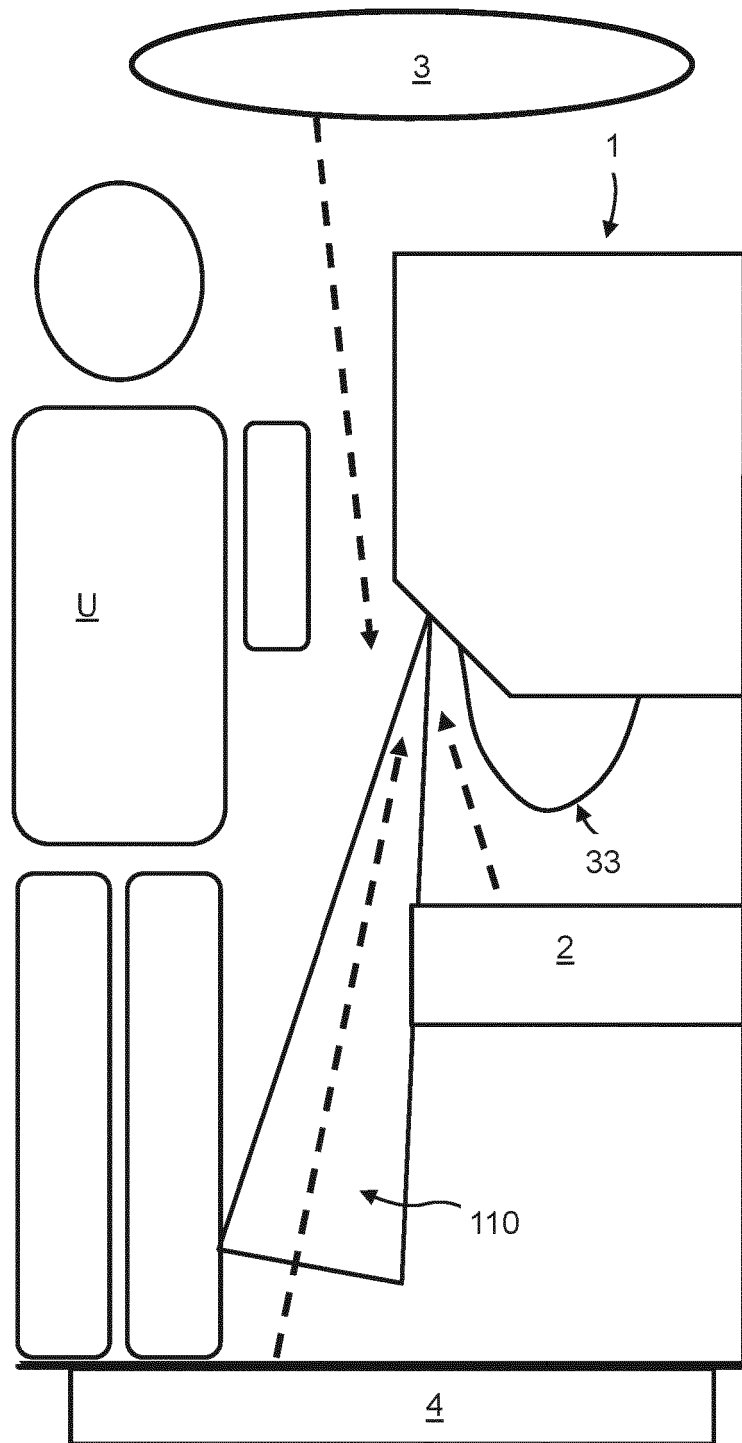

Fig. 13

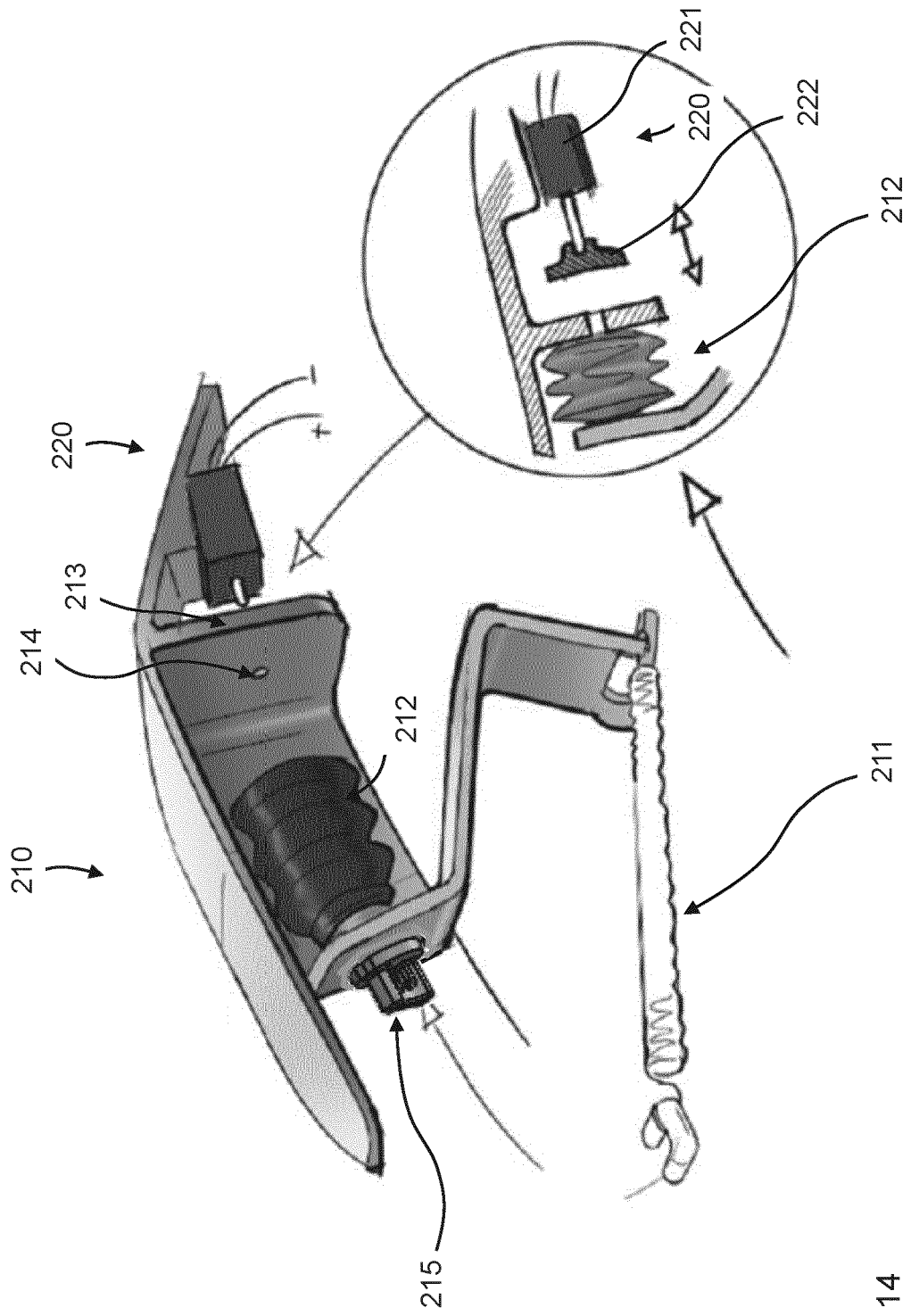

Fig. 14

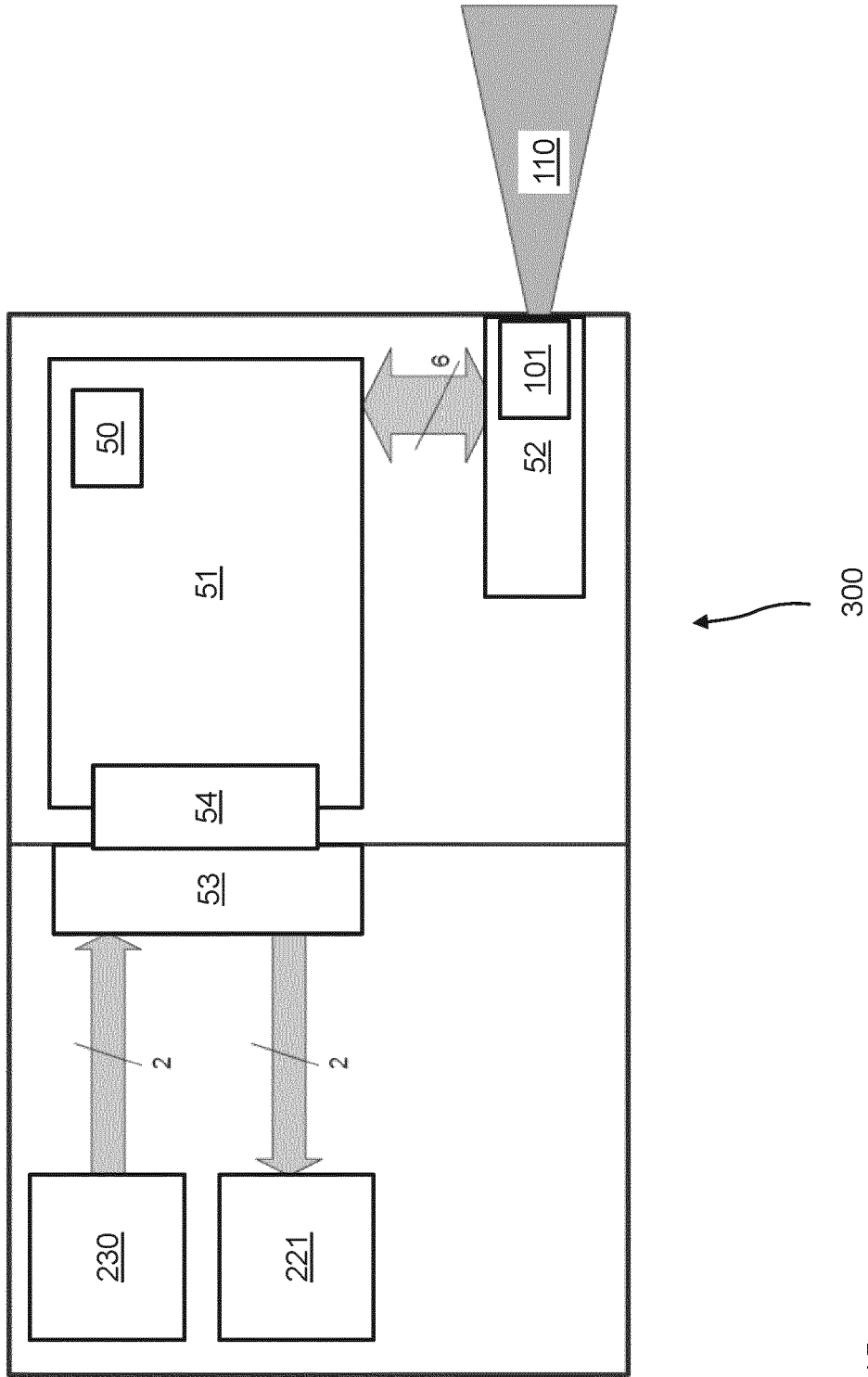

Fig. 15

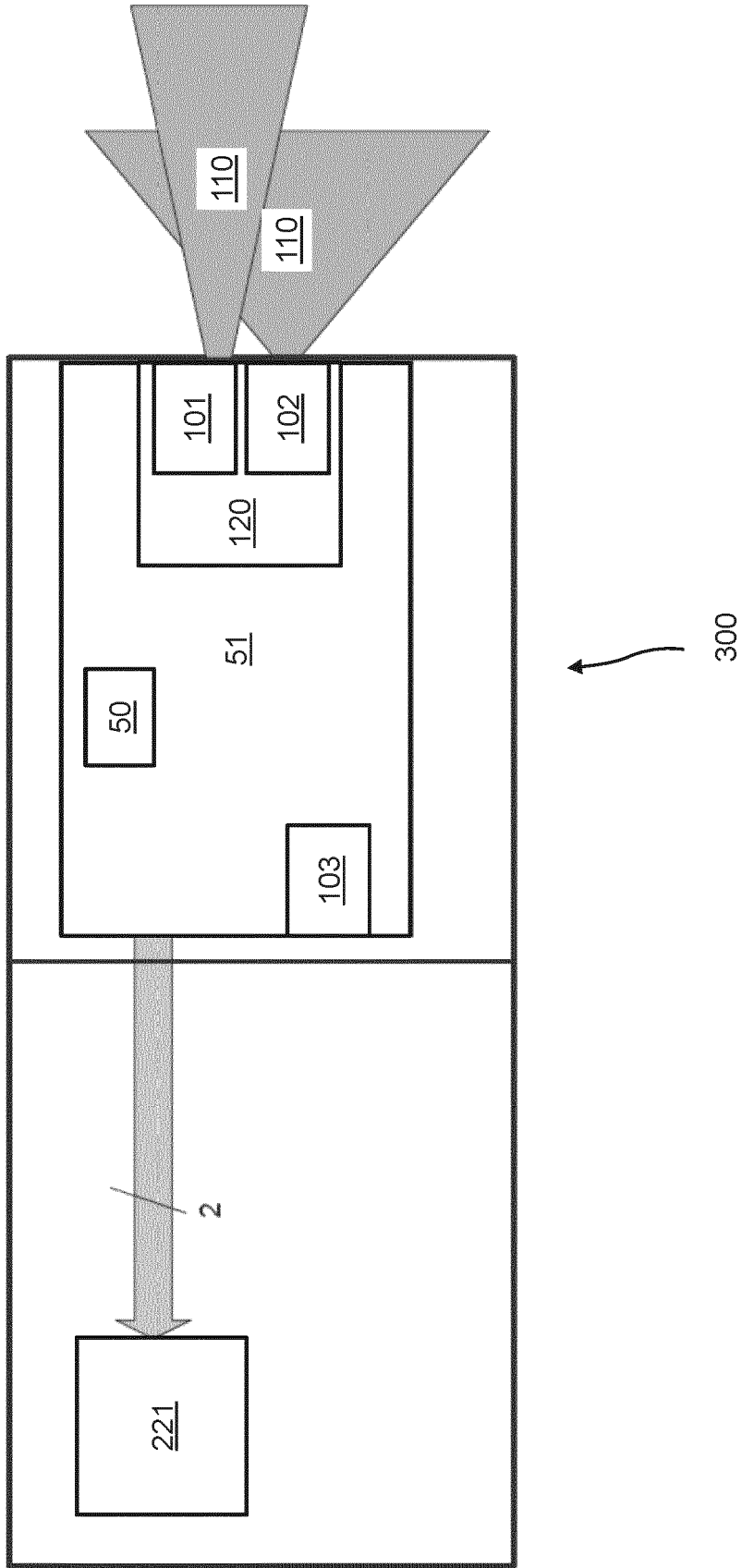

Fig. 16

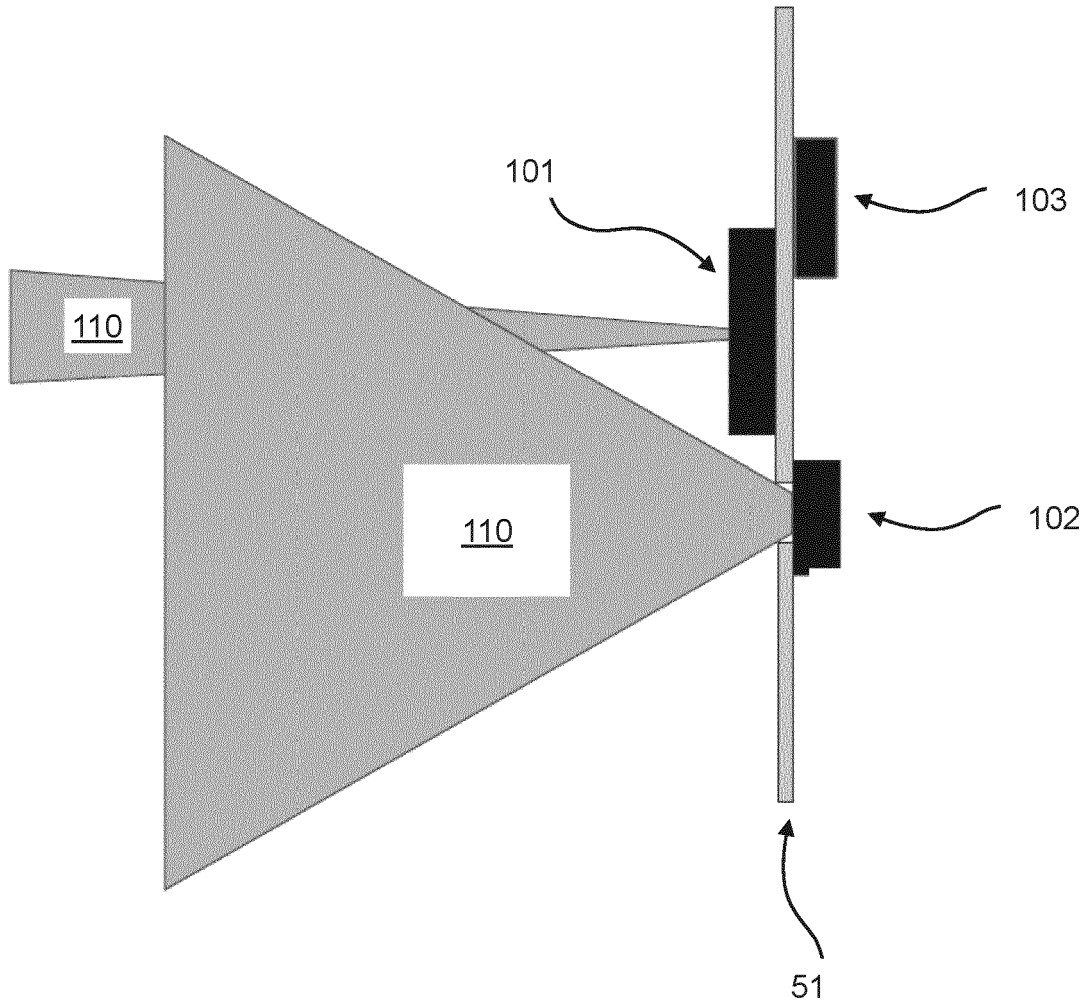

Fig. 17

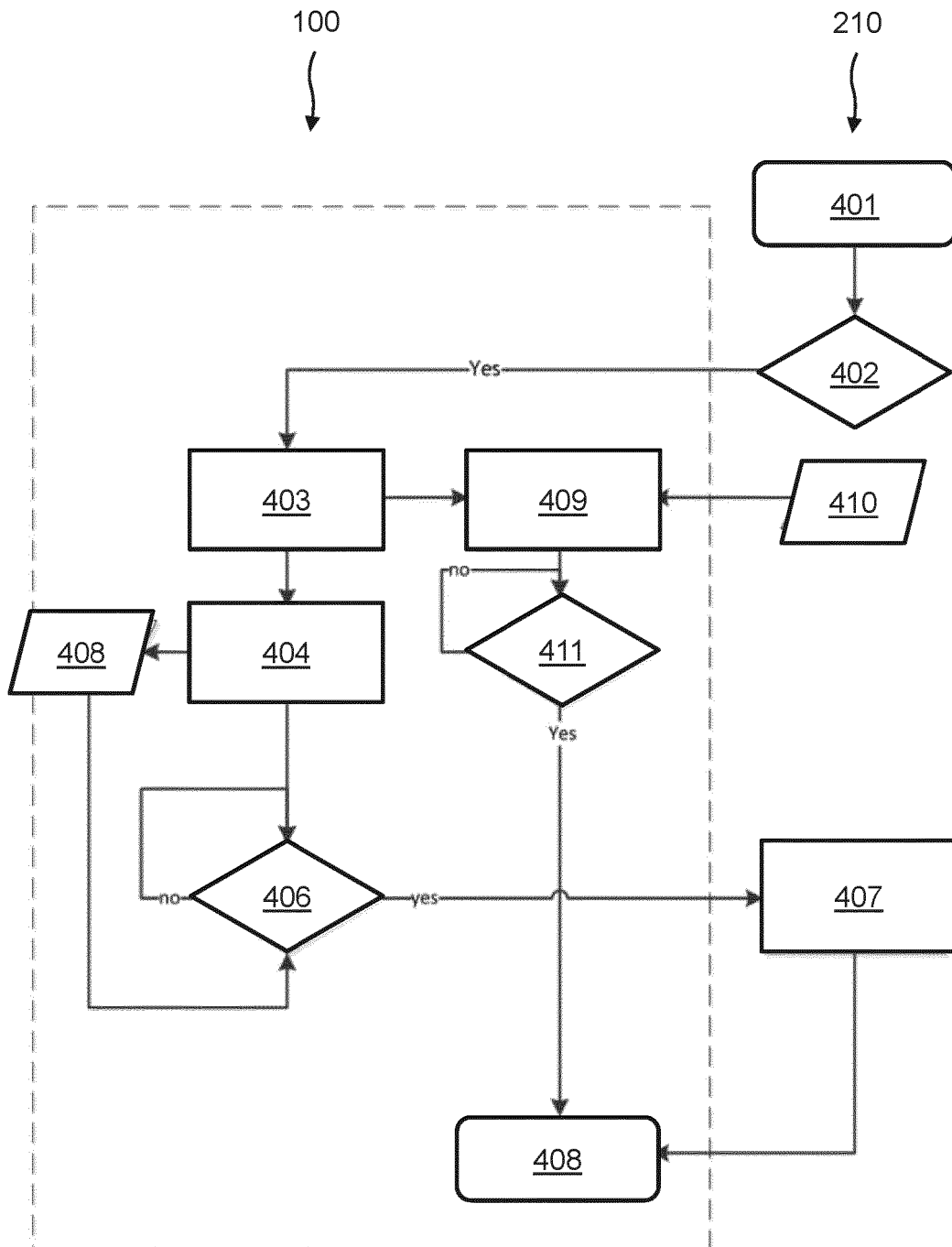

Fig. 18

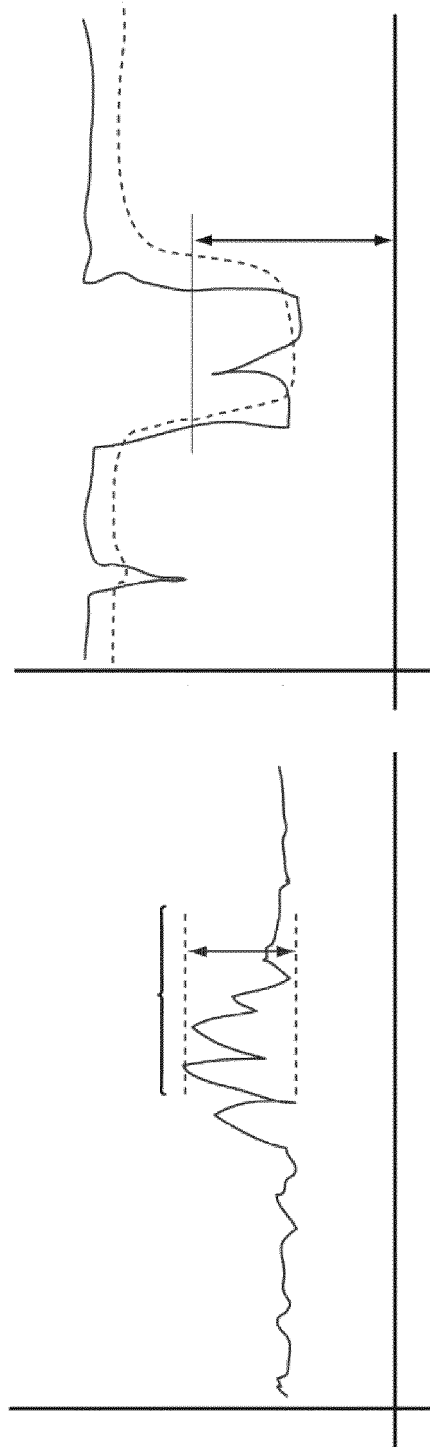

Fig. 19

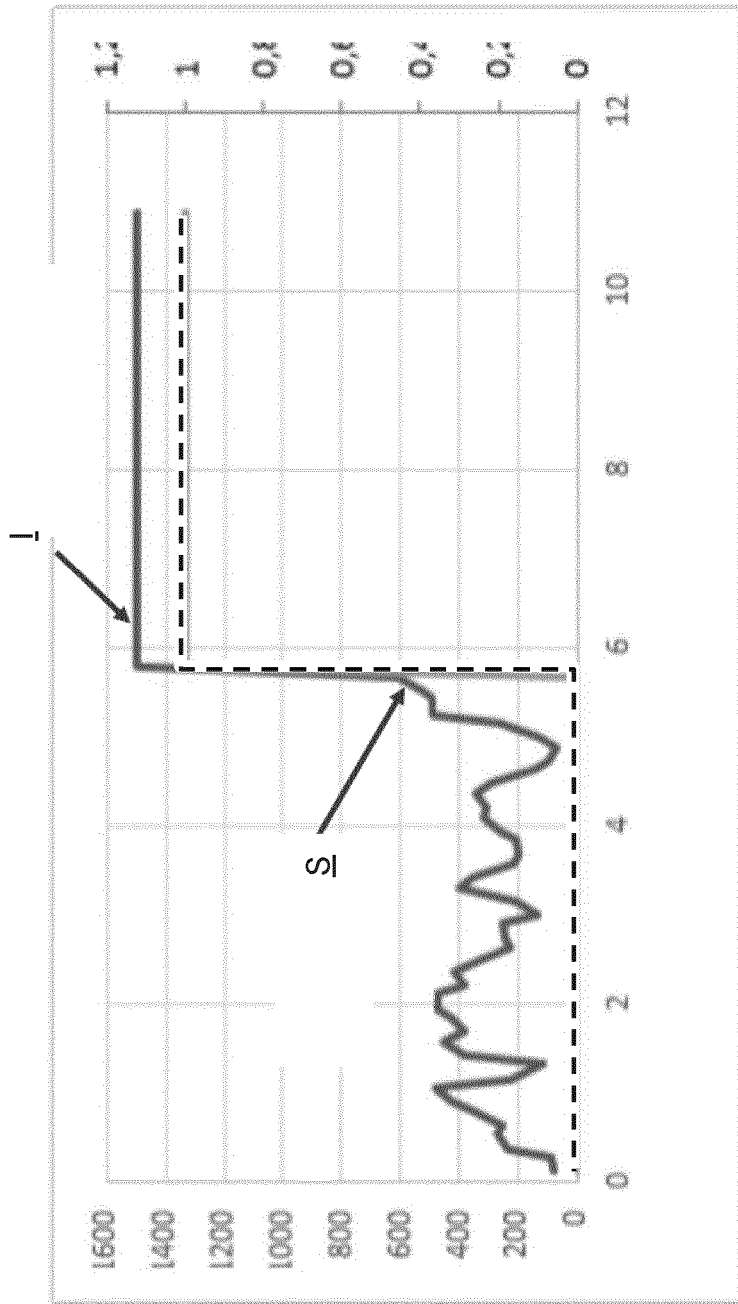

Fig. 20

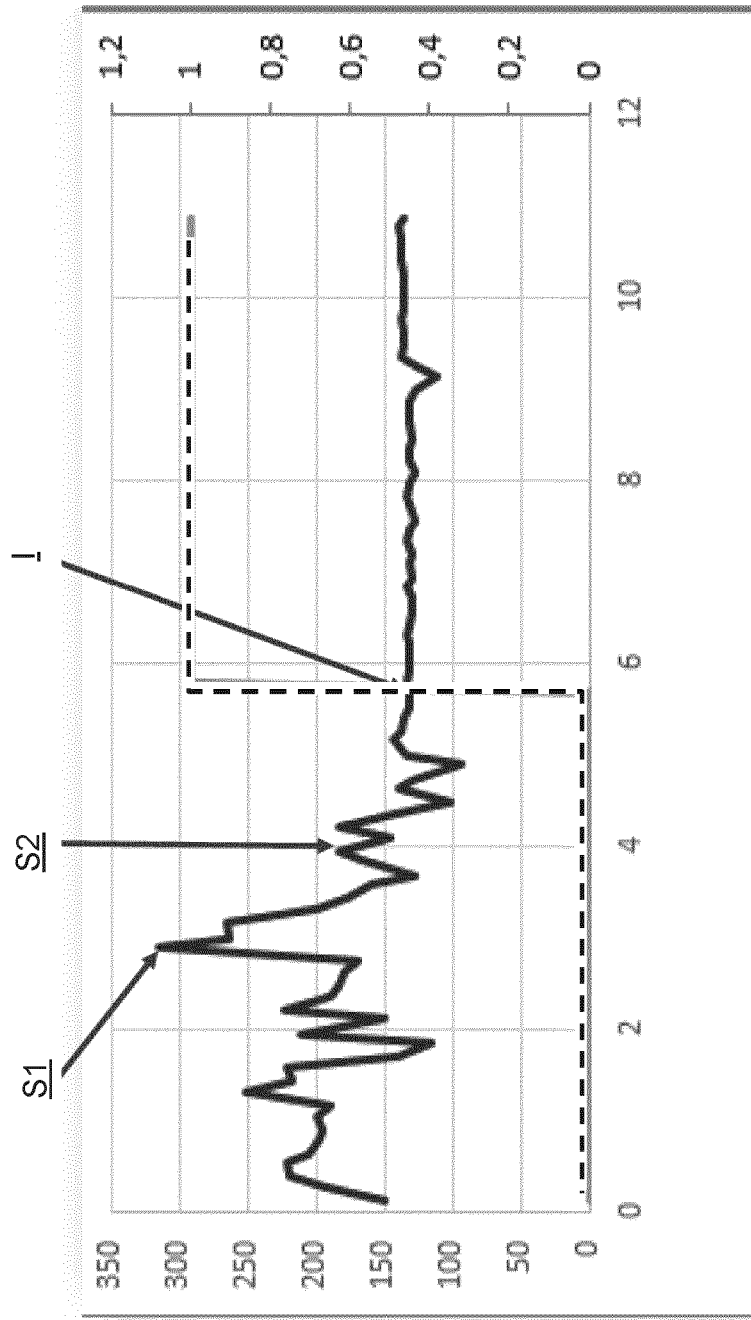

Fig. 21

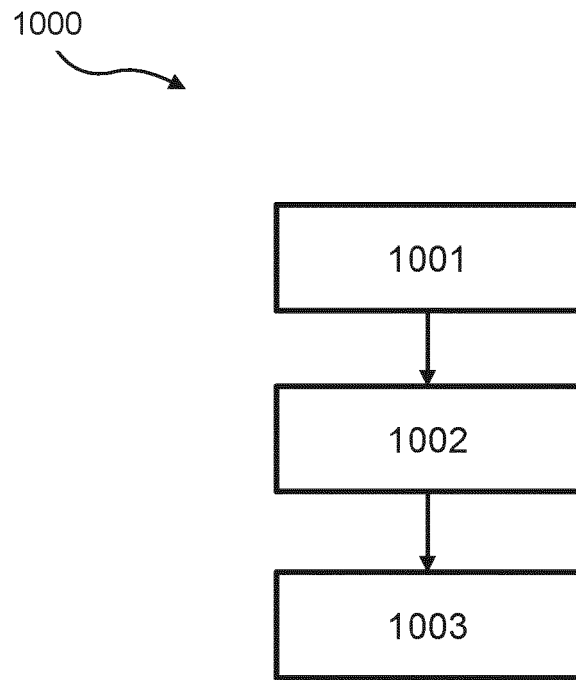

Fig. 22

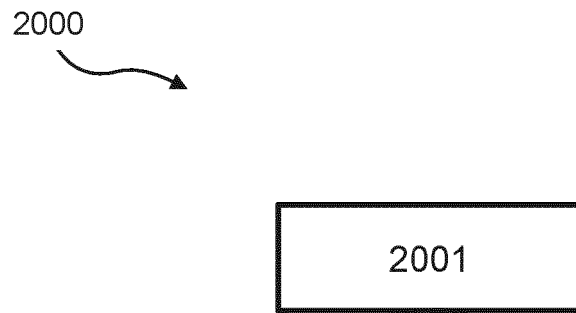

Fig. 23

REFERENCES CITED IN THE DESCRIPTION

This list of references cited by the applicant is for the reader's convenience only. It does not form part of the European patent document. Even though great care has been taken in compiling the references, errors or omissions cannot be excluded and the EPO disclaims all liability in this regard.

Patent documents cited in the description

- EP 1191872 B1 [0002]
- EP 2810259 B1 [0002]
- EP 0283554 B1 [0002]
- EP 0483314 B1 [0002]
- EP 2036479 A1 [0003]