

July 12, 1960

F. W. B. SMEATON

2,944,708

RETAINER FOR USE ON COLLAPSIBLE SQUEEZE TYPE CONTAINER

Filed Aug. 11, 1958

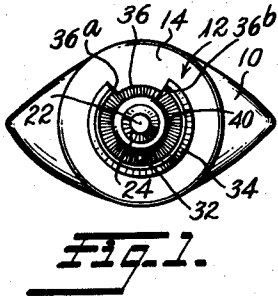

Fig. 1.

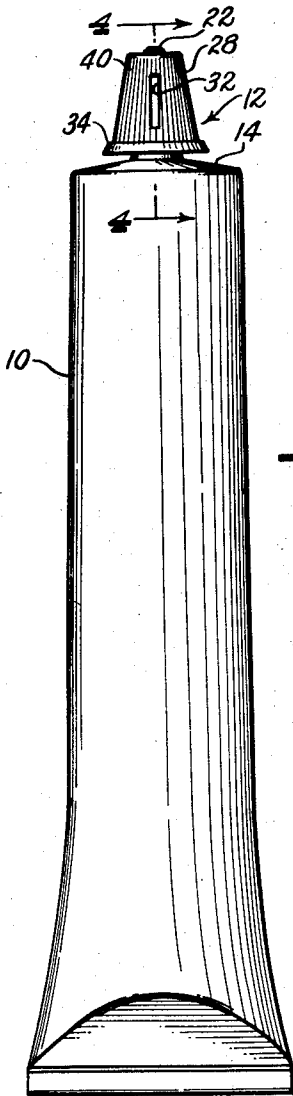

Fig. 2.

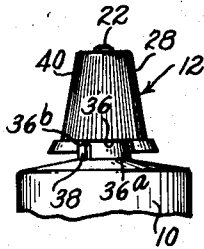

Fig. 3.

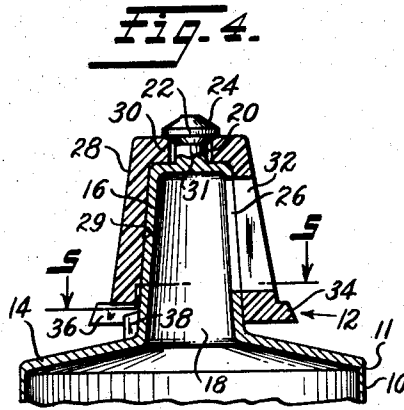

Fig. 4.

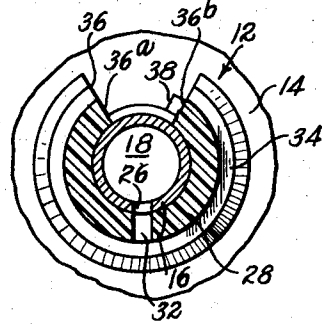

Fig. 5.

Fig. 6.

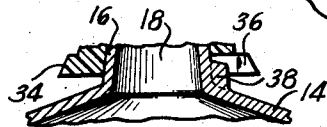
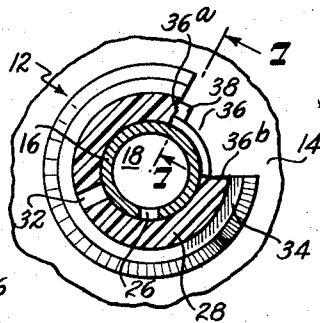

Fig. 7.

INVENTOR.
Frederick W. B. Smeaton

BY
Racon & Thomas

ATTORNEYS

1

2,944,708

RETAINER FOR USE ON COLLAPSIBLE SQUEEZE TYPE CONTAINER

Frederick W. B. Smeaton, 29 Sudbury St., St. John's, Newfoundland, Canada

Filed Aug. 11, 1958, Ser. No. 754,291

1 Claim. (Cl. 222-553)

This invention relates to a closure cap for a fluid container, and more particularly to a closure cap having a novel form of dispensing device adapted to be used with a collapsible container for tooth paste.

It is an object of this invention to provide a combination closure and dispensing cap, especially adapted for use with a collapsible squeeze-type, tube container, which can be manufactured easily, quickly and economically.

It is a further object of the invention to provide a closure cap assembly for the purpose described, which can be made of few parts of low-priced materials and which can be quickly and easily combined with a container.

It is a still further object of the invention to provide a closure cap assembly for the purpose described having a cap in the form of a movable sleeve valve and a cooperating member including a tubular portion having a movable sleeve valve serving to open or close a dispensing orifice in the tubular portion for dispensing a fluid, such as tooth paste.

Still another object is to provide a container closure including a rotatable cap, but wherein said cap can be rotatably mounted upon a discharge member for the container in permanent relation thereto without requiring the use of tools or riveting equipment.

With these and other objects in view, which will become apparent from a study of the description which follows, reference is made to the accompanying drawing of a preferred embodiment in which:

Fig. 1 is a top plan view of the collapsible tube and closure cap;

Fig. 2 is a front elevational view;

Fig. 3 is a fragmentary rear elevational view;

Fig. 4 is an enlarged fragmentary vertical sectional view substantially on the line 4-4 of Fig. 2;

Fig. 5 is a fragmentary horizontal sectional view substantially on the line 5-5 of Fig. 4, with the view as a whole turned 90° clockwise and showing the cap in open position;

Fig. 6 is a fragmentary horizontal sectional view similar to Fig. 5 but showing the cap in its closed position; and

Fig. 7 is a fragmentary vertical sectional view substantially on the line 7-7 of Fig. 6.

As shown in Fig. 2, a collapsible tube 10, made of heavy foil, such as lead, aluminum, tin, or other readily deformable material, contains a fluid material such as tooth paste, which may be dispensed therefrom by squeezing the tube, as is well known in the art. The upper end of the tube 10 is closed by a closure cap assembly designated in its entirety by the reference numeral 12.

The closure cap assembly 12 comprises a base member which may be made of the same metal as the tube 10, and a plastic cap or sleeve 28. The base 14 is of generally frusto-conical form and is conventionally secured at 11 to the tube 10 and merges into an elongated tubular portion or extension 16 which is open at its lower end and closed at its upper end. A passage 18 extends

2

through the base 14 into extension 16, communicating at its lower end with collapsible tube 10. The extension 16 is tapered, as shown, to form a frustum of a cone.

The closed upper end of the extension 16 is provided with an annular recess 20 spaced slightly below the upper end thereof, as shown in Fig. 4, leaving the extreme upper end in the form of a button 22 having an upper tapering or frusto-conical surface 24, for a purpose appearing hereinafter. The annular recess 20 has an axially extending bottom wall, a radially extending lower side wall, and an outwardly extending upper side wall, whereby the recess diverges away from the bottom wall, as clearly seen in Figure 4. An elongated, vertical, slot 26 is provided in the side wall of extension 16 in longitudinally spaced relation to the button 22 for the purpose of dispensing the contents of tube 10.

The cap or sleeve 28 has a cavity complementary to the extension 16 including an inner surface 29 conforming generally to the outer side surface of extension 16 and serves as a valving device for slot 26. The lower end of cap 28 is open to readily pass over the upper end of extension 16. The extreme upper end of cap 28 is provided with an internal flange 30 having an axial length intermediate the maximum and minimum axial length of annular recess 20 as shown in Figure 4, of annular recess 20, and an inner diameter slightly greater than the diameter of the neck portion 31 formed by said recess, but slightly smaller than that of the largest diameter of button 22. The cap 28 is made of a material having inherent resilient characteristics, such as those found in plastics, for example, any suitable known polyethylene material, for a purpose to be set forth hereinafter. A wall of the sleeve is provided with a slot 32 of substantially the same dimensions as slot 26 in extension 16. The lower end of cap 28 has a flanged base 34, a portion of which is cut away at 36 to form an arcuate recess, having abutments 36a and 36b at its ends, which cooperate with a fixed stop 38 carried by and preferably formed integral with the base 14. Referring to Fig. 7, it will be seen that stop 38 is made integral with the base 14 of the closure cap.

In assembling the device, the cap 28 is forced over the head or button 22 of the tubular extension 16, either manually or by mechanical means. The inherent resilient and flexible nature of the plastic material of which the cap 28 is made permits the internal flange 30 to distend or spread as it is forced over the frusto-conical or inclined surface 24 of button 22 until flange 30 slips into recess 20, as shown in Fig. 4. In pressing the cap 28 over tubular extension 16, the cap is first positioned on the extension 16 so that the stop 38 comes within the arcuate recess provided by cut away section 36. The engagement of the internal flange 30 in annular recess 20 positively retains the cap 28 against axial movement on extension 16 and frictionally retains the cap in any adjusted angular position, yet permits easy turning of said cap within the limits permitted by stop 38 striking the end walls or abutments 36a and 36b of cut away portion 36. In order to facilitate manual rotary movement of cap 28, its external surface is roughened by vertical serrations, as shown at 40, Figs. 1 and 3.

In operation, cap 28 is turned to one extreme position with abutment 36b in engagement with stop 38, as shown in Figs. 4 and 5, to bring the slots 26 and 32 in registry. Squeezing the sides of tube 10 will force the tooth paste therein through slots 26 and 32 in the form of a wide ribbon, which can easily be deposited on a tooth brush. In order to close dispensing slot 26, cap 28 may be turned clockwise to the position shown in Fig. 6, in which position stop 38 engages the opposite abutment 36a of cut away portion 36. Slot 26 is thereby closed to prevent further dispensing or accidental discharge of the tooth

paste. As pointed out above, the frictional fit between the internal flange 30 and the side walls of annular recess is effective to retain the cap 28 in its opened, closed, or any intermediate position.

While, in the description above, reference has been made to the use of the present closure cap with a container for the purpose of dispensing tooth paste, it is obvious that the cap could be used with collapsible or non-collapsible containers for dispensing other fluids, such as liquids, semi-liquids, or powders.

I claim:

A dispensing device, comprising: a metallic member of frusto-conical form adapted to serve as an outlet means for a container, said member including a tubular portion open at one end and closed at the other end, the closed end having an axial extension provided with an external annular recess adjacent the closed end, said annular recess defined by an axially extending bottom wall, a lower, radially extending, side wall, and an upper wall of frusto-conical form whereby the annular recess diverges radially outward from the bottom, the outer end of the extension beyond the recess being in the form of a button having an upper frusto-conical surface and a cylindrical surface between said frusto-conical surface and said annular recess, said tubular portion having a longitudinally extending opening in the wall thereof; and a hollow frusto-conical closure cap, of a plastic material having inherent resilient characteristics, including a frusto-conical skirt having an unbroken internal flange at its smaller diameter end, said internal flange being fitted within the annular recess, and having parallel inner and outer side walls and a thickness intermediate the minimum and maximum axial extent of said annular recess, whereby upon pressing engagement of the internal flange of the cap over the button, said frusto-conical surface facilitates enlargement and slipping of the internal flange of the cap over said button during positioning of the cap on the tubular portion, and whereby the internal flange resiliently engages only the side walls of the annular recess to frictionally retain the cap in any adjusted angular position and to positively retain the cap against axial movement, the

opening defined by said internal flange having a diameter slightly smaller than the cylindrical portion of the button-form extension and slightly larger than the diameter of the bottom wall of said annular recess to be expanded sufficiently to pass over the button-form extension and to be received in the annular recess with a clearance between the inner edge of the internal flange and the bottom wall of the recess, the inner surface of said frusto-conical skirt, throughout its axial length, frictionally engaging the outer tubular portion of said metallic member, a longitudinal opening through said frusto-conical skirt adapted to be placed in registration with the opening in the wall of the tubular portion upon rotation of said cap relative to the tubular portion to allow dispensing of the contents of the container, an external flange on the larger diameter end of said frusto-conical skirt, an arcuate recess, having radially extending side walls, in said flange, said recess being located in a position which is opposite that of the elongated opening in the skirt, and a fixed stop member, formed integrally with the tubular portion of the metallic member at its base adjacent the region of attachment to the container, said fixed stop extending into the arcuate recess to cooperate with the radially extending side walls to define the limits of rotation of the hollow cap relative to the metallic member, whereby the cap may be rotated within definite angular limits about said tubular portion to open and close the opening therein, while being frictionally retained in any position to which it may be rotated against angular movement, and positively retained against axial movement relative to said tubular portion.

References Cited in the file of this patent

UNITED STATES PATENTS

1,042,448	Kane	Oct. 29, 1912
1,764,973	Ohmart	June 17, 1930
1,951,544	Burrell	Mar. 20, 1934
2,197,052	Lowen	Apr. 16, 1940
2,765,954	Wohlbiel	Oct. 9, 1956
2,817,451	Giles et al.	Dec. 24, 1956