

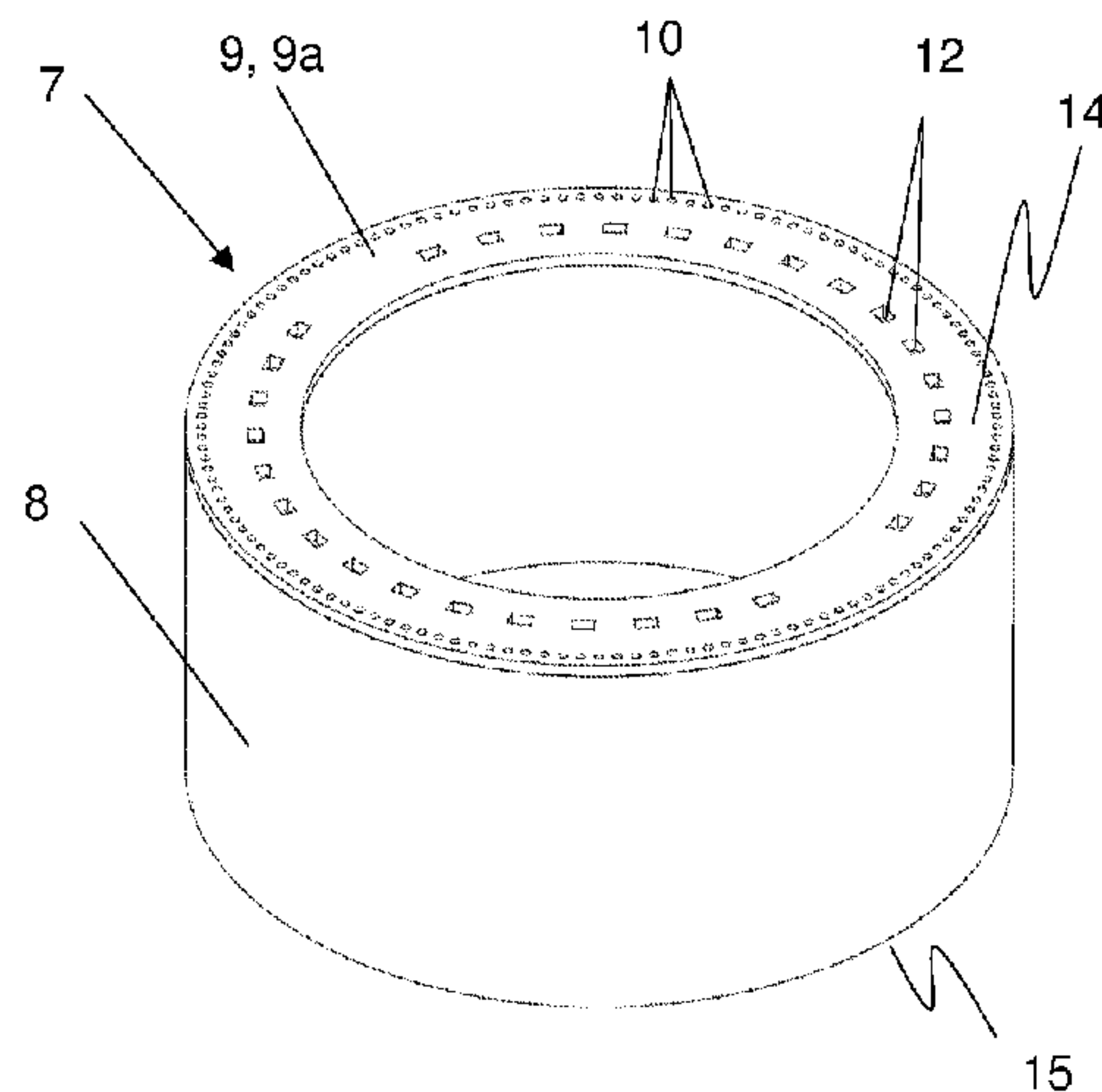

(86) Date de dépôt PCT/PCT Filing Date: 2011/05/04
(87) Date publication PCT/PCT Publication Date: 2011/12/22
(45) Date de délivrance/Issue Date: 2019/05/21
(85) Entrée phase nationale/National Entry: 2012/12/12
(86) N° demande PCT/PCT Application No.: EP 2011/057088
(87) N° publication PCT/PCT Publication No.: 2011/157476
(30) Priorités/Priorities: 2010/06/14 (DE10 2010 030 047.0);
2010/08/26 (DE10 2010 039 796.2)

(51) Cl.Int./Int.Cl. *E04H 12/00* (2006.01),
E04H 12/12 (2006.01), *F03D 1/00* (2006.01),
F03D 13/20 (2016.01)
(72) Inventeurs/Inventors:
BOGL, STEFAN, DE;
HIERL, MARTIN, DE;
KNITL, JOSEF, DE
(73) Propriétaire/Owner:
MAX BOGL BAUUNTERNEHMUNG GMBH & CO. KG,
DE
(74) Agent: NORTON ROSE FULBRIGHT CANADA
LLP/S.E.N.C.R.L., S.R.L.

(54) Titre : MAT COMPRENANT UNE PIECE ADAPTATRICE ET PROCEDE DE FABRICATION D'UN MAT
COMPRENANT UNE PIECE ADAPTATRICE
(54) Title: TOWER WITH AN ADAPTER PIECE AND METHOD FOR BUILDING A TOWER WITH AN ADAPTER PIECE



(57) **Abrégé/Abstract:**

The invention relates to a tower (1) comprising a lower tubular tower section (2) made of concrete, an upper tubular tower section (3) made of steel and an adapter piece (7) for connecting the two tower sections (2, 3). The adapter piece (7) consists of an annular concrete element (8) and a steel element (9), the steel element (9) containing at least one annular flange (9a) that covers preferably entirely a surface of the concrete element (8), said surface being at the top in the installed state. The steel element (9) is directly cast together with the concrete element (8), wherein the annular flange (9a) is completely underpoured, essentially without air inclusions. In a method for producing a tower (1) comprising an adapter piece (7), a steel element (9) having an annular flange (9a) is placed head down into an annular formwork in order to produce said adapter piece (7). A concrete material is then introduced into the formwork in order to produce an annular concrete element (8) of the adapter piece (7), whereby the concrete material is directly applied onto the subsequent bottom side of the flange (9a).

(12) NACH DEM VERTRAG ÜBER DIE INTERNATIONALE ZUSAMMENARBEIT AUF DEM GEBIET DES PATENTWESENS (PCT) VERÖFFENTLICHTE INTERNATIONALE ANMELDUNG

(19) Weltorganisation für geistiges Eigentum
Internationales Büro(43) Internationales Veröffentlichungsdatum
22. Dezember 2011 (22.12.2011)(10) Internationale Veröffentlichungsnummer
WO 2011/157476 A3

(51) Internationale Patentklassifikation:

E04H 12/00 (2006.01) *F03D 11/00* (2006.01)
E04H 12/12 (2006.01) *F03D 11/04* (2006.01)
F03D 1/00 (2006.01)

92318 Neumarkt (DE). **KNITL, Josef** [DE/DE]; Appianstrasse 44, 92342 Freystadt (DE).

(21) Internationales Aktenzeichen: PCT/EP2011/057088

(74) **Anwalt: BERGMEIER, Werner**; Friedrich-Ebert-Straße 84, 85055 Ingolstadt (DE).(22) Internationales Anmeldedatum:
4. Mai 2011 (04.05.2011)(81) **Bestimmungsstaaten** (soweit nicht anders angegeben, für jede verfügbare nationale Schutzrechtsart): AE, AG, AL, AM, AO, AT, AU, AZ, BA, BB, BG, BH, BR, BW, BY, BZ, CA, CH, CL, CN, CO, CR, CU, CZ, DE, DK, DM, DO, DZ, EC, EE, EG, ES, FI, GB, GD, GE, GH, GM, GT, HN, HR, HU, ID, IL, IN, IS, JP, KE, KG, KM, KN, KP, KR, KZ, LA, LC, LK, LR, LS, LT, LU, LY, MA, MD, ME, MG, MK, MN, MW, MX, MY, MZ, NA, NG, NI, NO, NZ, OM, PE, PG, PH, PL, PT, RO, RS, RU, SC, SD, SE, SG, SK, SL, SM, ST, SV, SY, TH, TJ, TM, TN, TR, TT, TZ, UA, UG, US, UZ, VC, VN, ZA, ZM, ZW.

(25) Einreichungssprache: Deutsch

(26) Veröffentlichungssprache: Deutsch

(30) **Angaben zur Priorität:**
10 2010 030 047.0 14. Juni 2010 (14.06.2010) DE
10 2010 039 796.2
26. August 2010 (26.08.2010) DE(71) **Anmelder** (für alle Bestimmungsstaaten mit Ausnahme von US): **MAX BÖGL BAUNTERNEHMUNG GMBH & CO. KG** [DE/DE]; Max-Bögl-Straße 1, 92369 Sengenthal (DE).(84) **Bestimmungsstaaten** (soweit nicht anders angegeben, für jede verfügbare regionale Schutzrechtsart): ARIPO (BW, GH, GM, KE, LR, LS, MW, MZ, NA, SD, SL, SZ, TZ, UG, ZM, ZW), eurasisches (AM, AZ, BY, KG, KZ, MD, RU, TJ, TM), europäisches (AL, AT, BE, BG, CH, CY, CZ, DE, DK, EE, ES, FI, FR, GB, GR, HR, HU, IE, IS, IT, LT, LU, LV, MC, MK, MT, NL, NO, PL, PT, RO, RS, SE, SI, SK, SM, TR), OAPI (BF, BJ, CF, CG, CI, CM, GA, GN, GQ, GW, ML, MR, NE, SN, TD, TG).(72) **Erfinder; und**(75) **Erfinder/Anmelder** (nur für US): **BÖGL, Stefan** [DE/DE]; Sportheimstraße 20, 92369 Sengenthal (DE).
HIERL, Martin [DE/DE]; Maria-Ferdinanda-Straße 8,

[Fortsetzung auf der nächsten Seite]

(54) **Title:** TOWER COMPRISING AN ADAPTER PIECE AND METHOD FOR PRODUCING A TOWER COMPRISING AN ADAPTER PIECE(54) **Bezeichnung :** TURM MIT EINEM ADAPTERSTÜCK SOWIE VERFAHREN ZUR HERSTELLUNG EINES TURMS MIT EINEM ADAPTERSTÜCK

Fig. 2

(57) **Abstract:** The invention relates to a tower (1) comprising a lower tubular tower section (2) made of concrete, an upper tubular tower section (3) made of steel and an adapter piece (7) for connecting the two tower sections (2, 3). The adapter piece (7) consists of an annular concrete element (8) and a steel element (9), the steel element (9) containing at least one annular flange (9a) that covers preferably entirely a surface of the concrete element (8), said surface being at the top in the installed state. The steel element (9) is directly cast together with the concrete element (8), wherein the annular flange (9a) is completely underpoured, essentially without air inclusions. In a method for producing a tower (1) comprising an adapter piece (7), a steel element (9) having an annular flange (9a) is placed head down into an annular formwork in order to produce said adapter piece (7). A concrete material is then introduced into the formwork in order to produce an annular concrete element (8) of the adapter piece (7), whereby the concrete material is directly applied onto the subsequent bottom side of the flange (9a).(57) **Zusammenfassung:**

[Fortsetzung auf der nächsten Seite]

WO 2011/157476 A3**Erklärungen gemäß Regel 4.17:**

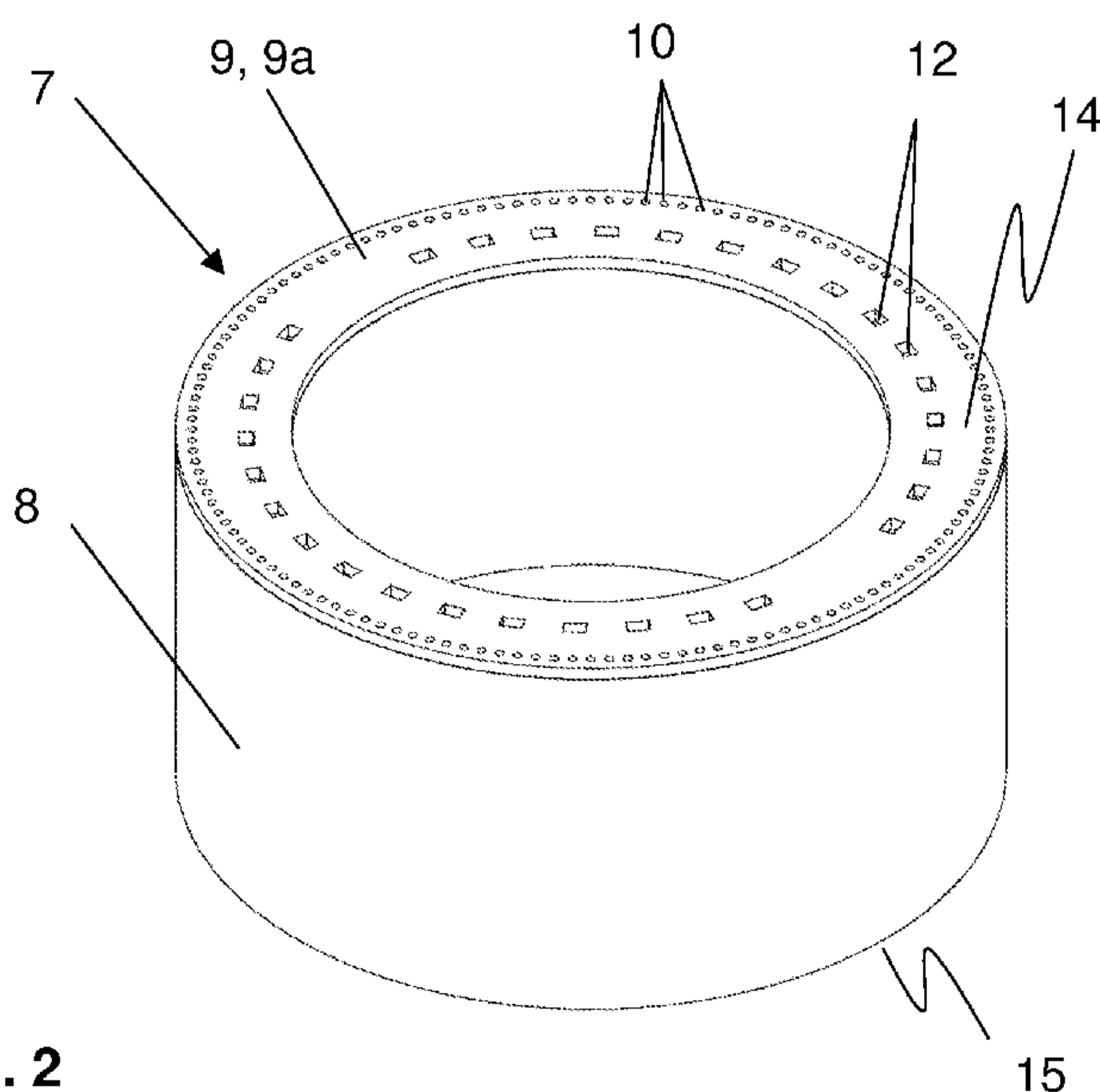
— *Erfindererklärung (Regel 4.17 Ziffer iv)*

— *vor Ablauf der für Änderungen der Ansprüche geltenden Frist; Veröffentlichung wird wiederholt, falls Änderungen eingehen (Regel 48 Absatz 2 Buchstabe h)*

Veröffentlicht:

— *mit internationalem Recherchenbericht (Artikel 21 Absatz 3)*

(88) Veröffentlichungsdatum des internationalen Recherchenberichts:

16. Februar 2012

Ein Turm (1) weist einen unteren rohrförmigen Turmabschnitt (2) aus Beton und einen oberen rohrförmigen Turmabschnitt (3) aus Stahl sowie ein Adapterstück (7) zur Verbindung der beiden Turmabschnitte (2, 3) auf. Das Adapterstück (7) besteht aus einem ringförmigen Betonelement (8) und einem Stahlelement (9), wobei das Stahlelement (9) zumindest einen ringförmigen Flansch (9a) beinhaltet, der eine in Einbaulage obere Oberfläche des Betonelements (8) vorzugsweise vollständig bedeckt. Das Stahlelement (9) ist mit dem Betonelement (8) direkt vergossen, wobei der ringförmige Flansch (9a) vollständig und im Wesentlichen ohne Lufteinschlüsse untergossen ist. Bei einem Verfahren zur Herstellung eines Turms (1) mit einem Adapterstück (7) wird zur Herstellung des Adapterstücks (7) ein Stahlelement (9) mit einem ringförmigen Flansch (9a) kopfüber in eine ringförmige Schalung eingelegt. Anschließend wird ein Betonmaterial in die Schalung eingebracht, um ein ringförmiges Betonelement (8) des Adapterstücks (7) herzustellen, wobei das Betonmaterial direkt auf die spätere Unterseite des Flansches (9a) aufgebracht wird.

Tower with an Adapter Piece and Method for Building a Tower with an Adapter Piece

This invention refers to a tower, especially a tower for a wind power plant, comprising a lower tubular section made of concrete and an upper tubular tower section made of steel, as well as an adapter piece for connecting the two tower sections. Furthermore, the invention refers to a method for building a tower.

Towers for wind power plants, especially if they are very high, are very often built as so-called hybrid towers, in which a lower tower section made of concrete and an upper tower section made of steel are placed on top of the tower section made of concrete. This hybrid construction method makes it also possible to erect towers with a considerable hub height, which would require a very large wall thickness in the foot if built purely of steel, applying a relatively easy construction method because the diameter of a tubular steel tower is limited owing to transportation reasons. In this context, connecting the tower section made of steel with the tower section made of concrete is extremely important because an optimal bearing load in the concrete must be ensured and damage to the concrete caused by stresses bearing on it must be prevented. Various options have been made known in the state of the art for connecting the steel section with the concrete section.

EP 1 654 460 B1 provides for casting a lower area of the tower section made of steel directly in the tower section made of concrete. To achieve this, the cast terminal area of the tower section made of steel has anchoring elements that protrude radially from the wall of the tower section. Several anchoring elements are provided along the height of the cast terminal area so that the applied loads can be distributed across the entire embedding area.

DE 20 2006 009 554 U1 provides a special adapter element made of steel that is largely ring-shaped and in which, in turn, anchoring elements extending in radial direction are arranged on the inner surface area of the annular steel adapter element. As a result of this, a direct deviation of traction forces without deflection should be allowed in the concrete body.

The disadvantage in connecting the steel tower with the concrete tower lies in the fact that when building the tower section of concrete, the steel tower with its especially developed terminal area or at least the especially developed adapter element must already be available so it can be cast in the tower section made of concrete.

The task of the present invention is to suggest a tower with an adapter element to allow a simple and flexible building of the tower with a good bearing load. Furthermore, a corresponding method should be suggested.

The task is solved with the features of the independent claims.

A tower, especially a tower for a wind power plant, has a lower tubular section made of concrete and an upper tubular tower section made of steel. Furthermore, the tower has an adapter piece for connecting the two tower sections. According to the invention, the adapter piece comprises an annular concrete element and a steel element that has at least one annular flange. In this case, the flange covers an upper surface of the concrete element in

installation position, preferably fully. Consequently, the adapter piece according to the invention consists of concrete and steel, in which case the steel element is cast directly with the concrete element. Here, the annular flange of the steel element is fully grouted in the concrete without air inclusions. In a method for building a tower, a steel element with an annular flange is initially provided for building the adapter piece, which is installed headlong in a ring-shaped formwork. Afterwards, concrete is placed in the formwork and as a result of that, the inner annular concrete element of the adapter piece can be made. Here, the concrete is placed directly on the underside of the flange so that, in the finished adapter element, the flange is fully grouted and there is a good connection between the concrete element and the steel element.

Since the adapter piece according to the invention contains one concrete element and one steel element, it can be easily built independently from the tower section made of steel and the tower section made of concrete and only afterwards be connected to the two tower sections because the critical connection between steel and concrete is achieved by the direct pouring in of the steel element into the concrete element. The headlong pouring of the concrete element with the steel element can achieve that the annular flange be fully grouted largely without air inclusions. As a result of this, a high, dense concrete quality is achieved directly under the flange, so that the highly stressed contact surface between steel and concrete is especially suitable for the load bearing and force resistance of the forces transferred by the steel tower. In this case, the use of concrete grout is not necessary. As a result of this, the adapter piece according to the invention can be used both for towers built with prefabricated parts and for fabrication at the place of installation. Moreover, the flange of the steel element facilitates the erection and assembly of the tower because the latter can serve simultaneously for connection with the upper tower section made of steel and attachment or fixation of tension elements and can additionally fulfill other functions, as described below.

According to an advantageous further innovation of the invention, the adapter piece has an inner annular concrete element and an outer annular steel element that contains the annular flange in its upper end. The annular steel element located outside makes it possible to greatly improve the sealing between the concrete section and the steel section and protect the upper area of the concrete element, especially from waterlogging. Likewise, reinforcements and anchoring elements cast in the concrete are protected from corrosion. Furthermore, this can increase the load-bearing capacity of the concrete element.

When producing the adapter piece, it is especially advantageous to use the steel element at least partially as formwork for the inner concrete element. The effort needed for producing such formwork can be reduced, thus facilitating the stripping too depending on execution.

The load-bearing capacity of the adapter piece is furthermore improved when the microstructure of the concrete elements has the highest density in the upper end of the concrete element in installation position because the exertion of force in one place takes place with an especially dense microstructure without air inclusions. This can also be ensured by the fabrication of the adapter element according to the invention, which is done rotated by 180°.

Especially advantageous is furthermore for the adapter piece made of steel and concrete according to the invention to be made independently from the tower sections. If the adapter piece is made as prefabricated part, it is available at the desired point in time and can be

connected at any time to one of the two tower sections or to both of them regardless of the production method and production site.

According to an especially advantageous further innovation of the invention, the steel element can have a largely U-shaped cross section encompassing an upper area of the concrete element. Apart from good sealing and protection of the reinforcements, an adapter piece with an especially high load-bearing capacity can be made as a result of this. In this case, the concrete element is surrounded by the steel element, so that a three-axial tensioning state can be achieved in the concrete element.

If the concrete element of the adapter piece is made from high-performance concrete, particularly one having a quality of C 50/60 or higher, it is especially suitable for connection to both tower sections and absorbing the force from the tower section made of steel. Especially if used with a steel element that encompasses the concrete element in U-shape, a concrete quality of C 50/60 can already be achieved for utilization.

It is furthermore advantageous for the flange of the adapter piece to preferably have many bore holes distributed over its external circumference so the fastening elements for fixing the tower section made of steel in place can be inserted through them. It is furthermore advantageous for the flange to preferably have many bore holes distributed over its inner circumference so the pre-stressing tendons for bracing the tower section made of concrete can be inserted through them and also fastened on the upper side of the flange. Thus, the flange of the steel element serves not only for protecting the concrete element with its reinforcements and the force exertion coming from the steel tower but also for fixing the pre-stressing tendons and the steel tower in place.

Jacket tubes are preferably cast in the concrete element so the pre-stressing tendons can be led through them and fixed in place on the steel element flange. The adapter piece can thus serve for connecting the two tower sections and simultaneously for placing an initial stress on the tower section made of concrete and anchoring the pre-stressing tendons. Especially advantageous here is to fasten the tower section made of steel independently from anchoring the pre-stressing tendons, so that the assembly or disassembly of individual elements is made possible independent from one another.

It is also particularly advantageous to embed numerous anchoring bolts in the concrete element of the adapter piece in a preferably perpendicular position so the tower section made of steel can be fixed in place with them. The exertion of force coming from the steel tower to the adapter element can take place advantageously as a result of this. In addition, this allows the tower section made of steel to be easily mounted. In this case, the tower section made of steel can be fastened directly on the embedded anchoring bolts or be connected to them with other fastening elements.

It is furthermore advantageous if the anchoring bolts extend through and beyond the steel element flange across the upper side of the flange. For mounting the tower section made of steel, it must be merely placed on the flange with its corresponding bore holes and can be fixed in place with nuts, for example. By fixing the tower section made of steel in place with the anchoring bolts, an initial stress can be simultaneously and advantageously placed on the concrete element of the adapter piece to further improve the latter's load-bearing

capacity. To allow subsequent bracing, the anchoring bolts have a separating layer or are set in concrete in a jacket tube.

According to a particularly advantageous further innovation of the invention, the pre-stressing tendons can be fixed in place without anchoring bolts directly on the steel element flange. The especially good connection of the steel flange to the concrete element allows the steel flange to directly take over the load distribution function, so that no additional elements are needed. This facilitates assembly even more.

An advantageous execution of the invention provides that at least one lower surface of the adapter piece is smoothed or milled over after the concrete has hardened, preferably parallel to the upper surface of the flange in installation position. The parallelism of the lower contact surface of the adapter piece with regard to the upper flange surface can be easily ensured as a result of this. A refinishing of the upper flange surface of the steel flange before or after casting can also be provided for to achieve the highest possible parallel position and even surface.

Regardless of – or also in combination with – the adapter piece described above, it is advantageous for a tower having a lower annular tower section made of concrete and an upper tubular section made of steel that its lower tower section be made of annular- or annular segment-shaped prefabricated concrete parts. This especially facilitates the flexible building of the tower, as the prefabricated concrete parts can be fully manufactured in advance and put together upon arrival at the assembly site.

Preferably, the prefabricated concrete parts are braced dry against one another to facilitate the assembly of the tower section made of concrete even further. The high-quality execution of the contact surfaces makes a sealing of the joints unnecessary.

To seal a horizontal contact joint between the prefabricated concrete parts, however, a sealing profile can also be provided. To achieve this, the prefabricated concrete parts can have a nut for the sealing profile. Additionally, the sealing can be done with epoxy resin.

Especially advantageous here is when the prefabricated concrete parts are braced by means of external pre-stressing tendons running inside the tower. In this case, at least two pre-stressing tendons extend between one foot section of the tower and the upper adapter piece. Additional pre-stressing tendons can either be braced between the foot of the tower and the upper adapter piece or only up to partial heights of the tower. For example, every second tensioning element can extend all the way to the adapter piece while the other half of the pre-stressing tendons is anchored at one-half of the height or another partial height.

In order to also allow the horizontal contact surfaces of the prefabricated concrete parts to be parallel in the tower section made of concrete and therefore facilitate simple onsite assembly, at least one of the two horizontal contact surfaces is processed in a way to remove material, for example by regrinding it or milling it over. During onsite assembly, the individual prefabricated concrete parts must therefore be placed only on top of one another without needing additional adjusting or leveling work. To process the horizontal contact surfaces, it is especially advantageous if both horizontal surfaces are processed in a clamping fixture. In this case, the annular- or annular segment-shaped prefabricated concrete parts are rotated around their own axis during processing. If need be, a leveling

layer (such as an epoxy resin) can be applied on the contact surfaces to smoothen out uneven patches.

If the annular prefabricated concrete parts consist of two or more annular segments, then it is furthermore advantageous if vertical contact joints are also executed dry between the contact surfaces of the annular segment-shaped prefabricated concrete parts. Here, the ring segments are braced in horizontal direction, preferably with diagonally arranged pre-stressing tendons with screws, for example. However, the joint can also be made without screw connections, in which case the vertical joint is held together only by the vertical tension of the tower section made of concrete. On successive rings, the ring segments of a ring are in each case arranged in a twisted position with respect to one another.

According to another advantageous further innovation of the invention, the prefabricated concrete parts have at least one recess on their contact surfaces, preferably at least one bore hole, so one element can be inserted in it in each case for securing the position or twisted position. This element can be a plastic dowel. Preferably, several bore holes are distributed evenly across the perimeter in this case.

Further advantages of the invention are described with the help of the embodiments shown below, which show:

- Fig. 1** an overview of the tower according to the invention with a concrete section, a steel section and an adapter piece,
- Fig. 2** a perspective view of an adapter piece according to the invention,
- Fig. 3** a cross section of an adapter piece according to the invention,
- Fig. 4** a view of an annular prefabricated concrete part for a tower according to the invention, and
- Fig. 5** a cross section of an adapter piece according to the invention with an alternate fastening of the tower section made of steel.

Fig. 1 shows a perspective view of a tower 1, for a wind power plant, for example. The tower 1 has been executed as a hybrid tower, for which a lower tubular tower section 2 made of concrete and an upper tubular tower section 3 made of steel have been provided. Furthermore, the tower 1 has a foot section 4 or a foundation. On the tower section made of steel 3, a nacelle and rotor are arranged in a known way, but are not shown here.

Here, the tower section 2 made of concrete is made of individual, annular pre-fabricated concrete parts 5, which consist in each case, in turn, of two ring segments 6, as can be seen in Fig. 4. As a result of this, huge towers with very large diameters in their foot areas can be favorably built using the prefabricated construction method because the individual prefabricated parts can be easily transported. The tower section 3 made of steel can be prefabricated as one single part and brought to the assembly site or likewise be made of several parts put together at the assembly site or already earlier in a production site. To easily and flexibly connect the tower section 2 made of concrete and the tower section 3 made of steel, an adapter piece 7 is provided.

The adapter piece 7 according to the invention (Fig. 2) consists of an annular concrete element 8 and a steel element 9, executed here in the shape of an annular flange 9a. As can be seen here, the flange 9a fully covers the upper surface of the concrete element 8 in installed position to protect it well against the penetration of humidity. Thus, flange 9a is a seal between the tower section 2 made of concrete and the tower section 3 made of steel. The steel element 9 has in this case numerous bore holes 10 distributed on its external perimeter for insertion by bolts 11 (see Fig. 3) to fasten the tower section 3 on it. Furthermore, the steel element 9 has openings 12 on the internal perimeter of the flange 9a through which pre-stressing tendons 13 (see Fig. 3) can be inserted and fastened to the flange 9a while the tower is assembled.

The adapter piece 7 according to the invention is made by placing the steel element 9 headlong (i.e. with the subsequent upper side 14 downwards) into an annular formwork (not shown here). Afterwards, the concrete is directly applied on the subsequent underside of the flange 9a. By manufacturing the adapter piece 7 rotated by 180° for later installation position, the concrete element 8 can be made from particularly high quality in the upper head area of the concrete element 8 that will subsequently rest above it. Thus, the concrete element 8 has in its head area a very dense concrete microstructure with few air inclusions. By directly covering the subsequent lower side of flange 9a with concrete, it can be fully grouted, thus making the highly stressed contact surface of high quality and largely without air inclusions. In this case, it is advantageous for steel element 9 to be directly a part of the formwork (not shown); here, the flange 9a forms an underside of the formwork. After removing the formwork, the adapter piece 7 can remain stored headlong until final solidification of the concrete so that the highly stressed head area of the adapter piece can be made of high quality. After formwork removal and adapter piece 7 solidification, the lower surface 15 of the adapter piece 7 and, if necessary, the upper side 14 of the flange 9a, are processed for removing material in order to ensure parallelism. As a result of this, no more adjustment work is necessary during subsequent assembly.

Owing to the design according to the invention, the adapter piece 7 can be manufactured favorably as a prefabricated part with a concrete element 8 and a steel element 9, thus allowing its full production independently from the manufacturing of the tower sections 2 and 3 out of concrete and steel. By means of the adapter piece 7 according to the invention, it is therefore possible to erect a tower 1 completely or partially with the prefabricated construction method at the assembly site. Here, it is particularly advantageous that the manufacturing of the tower sections 2 and 3 and of the adapter piece 7 can take place at different times and this increases the flexibility of the adapter piece 7 and the assembly options. Hence, the adapter piece 7 is also suitable for off-shore installations. So the adapter piece design can allow road transportation, its maximum height of 3.80 m and exterior diameter of 3 to 8 m is advantageous. If road transportation is not necessary, the adapter piece 7 can be manufactured with any dimensions.

Fig. 3 shows a section drawing of another design of an adapter piece 7 according to the invention. Contrary to the drawing of Fig. 2, the adapter piece 7 contains an inner annular concrete element 8 and an outer annular steel element 9 that in the upper end of its installation position has an annular flange 9a pointing inwards. It is particularly advantageous for the steel element 9 to be largely executed in a U-shape in a cross section (as shown here) so that it encompasses the upper area of the concrete element 8. As a

result of this, an especially good connection between the concrete element 8 and the steel element 9 as well as particularly good load-bearing capacity of the concrete element 8 can be ensured.

As can also be seen in Fig. 3, numerous perpendicularly oriented anchoring bolts 11 are embedded here in the concrete element 8 of the adapter piece 7. In this case, the anchoring bolts 11 are guided by the corresponding bore holes 10 of the flange 9a and protrude above the upper side 14 of the adapter piece. When subsequently assembling the tower 1, only the tower section 3 made of steel – which has a fastening flange 16 with numerous fastening bore holes 17 distributed over the circumference in its foot area – can be guided through the anchoring bolts and then fastened. The anchoring bolts 11 can be provided with a separating agent so they are not directly connected to the concrete element 8 and can be disassembled again. This makes it possible to disassemble the tower 1 or exchange the anchoring bolts 11 later during maintenance. Likewise, the anchoring bolts 11 can also be cast in a jacket tube to allow disassembly and exchange.

As can also be seen in Fig. 3, the flange 9a of the adapter piece 7 has numerous openings 12 for fixing the pre-stressing tendons 13 in place. In addition jacket tubes 19 are cast in the concrete element 8 of the adapter piece 7 to facilitate a subsequent advantageous bracing of the pre-fabricated concrete parts 6. To accomplish this, the pre-stressing tendons 13 are guided through the jacket tubes 19 in the concrete element 8 and the openings 12 in the flange 9a and fixed in place on the upper side 14 of the flange 9a. Here, the pre-stressing tendons 13 have been fastened directly on the flange 9a without anchoring plate. As shown here, a wedge plate 20 is merely placed under if the pre-stressing tendons 13 run obliquely. Thanks to the embodiment of the flange 9a according to the invention (which is very well connected with the concrete element 8), it can at the same time take over the function of a load-distributing plate.

In the installed position, the adapter element 7 has a recess 21 on the lower end so that the pre-stressing tendons are merely led within the wall of tower 1 in the area of the adapter piece 7 and otherwise extend along the interior of the tower outside the wall down to the foot section 4 of the tower 1, where they are also anchored. However, to guide the pre-stressing tendons 13, they could also be fastened or at least guided at certain distances along the height of the tower by means of suitable fastening or guidance elements. Instead of the initial stress accomplished with external pre-stressing tendons 13 shown here, initial stress can naturally also be exerted on the tower section made of concrete 2 with pre-stressing tendons 13 placed in the concrete cross-section.

The prefabricated concrete parts 5 of the tower section 2 made of concrete are placed dry on top of one another during the assembly of the tower section 2 and braced against one another. The prefabricated concrete parts 5 (see Fig. 4) – which in this case consist of two ring segments 6 each – have one upper and one lower horizontal contact surface 21. At least one of the contact surfaces 21 of the prefabricated concrete parts 5 is processed to remove the material (i.e. smoothed). As a result of this, it is possible to create an even contact surface 21 that allows the easy build-up of the tower section 2 without time-consuming adjustment work. Furthermore, by polishing the contact surfaces 21, a smooth and even contact surface 21 is achieved, so that the prefabricated concrete pieces 5 can be braced. This simplifies assembly and allows a disassembly to take place at any time.

If the annular prefabricated concrete parts 5 consist of two or several ring segments 6 (as is shown here), then vertical contact joints 23 are provided in every ring 5 of the tower 1. These are also preferably executed dry as well. So the individual ring segments 6 can be fixed against one another, diagonally arranged threaded joints (not shown) can be provided in the area of the vertical contact joints 23. However, a fixation of the ring segments 6 with respect to each other can also be accomplished solely through the preload force of the prestressing tendons 13 and offsetting the individual ring segments 6 in every ring 5. Here, the vertical contact joints 23 of the following ring 5 are offset by 90° in each case (see Fig. 1).

As additionally shown in Fig. 4, the prefabricated concrete parts 5, 6 can have one or several recesses 24 – in this case, bore holes – on their contact surfaces 21. A plastic dowel, for example, can be placed in them (not shown) for engaging in the prefabricated concrete part 5, 6 lying on top in order to prevent the prefabricated concrete parts 5, 6 from being twisted or horizontally displaced. Instead of a plastic dowel, another element from the most varied materials can be used for securing the position and preventing twisting. An especially good fixation of the individual prefabricated concrete parts 5, 6 with respect to one another can be achieved if – as shown here – several dowels or recesses 24 are arranged so they are distributed over the circumference of the prefabricated concrete part 5, 6.

The schematic cross-section diagram of Fig. 5 shows an alternative embodiment of an adapter piece 7 for connecting a tower section made of concrete 2 with a tower section made of steel 3. Contrary to the drawing of Fig. 3, the anchoring bolts 11 set in the concrete element 8 of the adapter piece 7 do not extend beyond the upper side 14 of the adapter piece, but just below the upper side 14. In addition, a threaded socket 25 has been cast on the upper side 14 of the adapter piece 7 or of the concrete element 8 that is screwed onto the cast anchoring bolt 11. Here, the threaded socket 25 is also shown in section. The flange 9a of the steel element 9 also has a corresponding number of bore holes 10 through which additional fastening elements 26 for fastening the tower section 3 made of steel can be inserted. Here, the tower section 3 made of steel is fastened with several threaded bolts, which can be inserted through the fastening flange 16 of the tower section made of steel 3 and the flange 9a for subsequent screwing onto the cast socket 25. As a result of this, the adapter piece 7 can be made and transported in an especially favorable way because no protruding parts exist. Even in this embodiment, a disassembly of the tower section made of steel 3 is easily possible. So the cast anchoring bolts 11 can be exchanged, they can also be provided with a separating agent or be cast in a jacket tube. Furthermore, the anchoring bolts 11 can, at the same time, be advantageously used for exerting a preload on the adapter piece 7. A lower anchoring plate and – if need be – a fastening nut are in this case securely embedded in the concrete element 8.

Additionally, in Fig. 5 the fastening flange 16 of the tower section made of steel 3 is executed somewhat smaller than the adapter piece 7, so that it can be arranged offset towards the inside on the adapter piece 7. This makes it possible to achieve a favorable load of the concrete element 8 and an improved absorption of compression stress forces.

The invention is not limited to the embodiments shown. Modifications and combinations also fall within the scope of the invention.

Patent Claims

1. Tower with a lower tubular tower section made of concrete and an upper tubular tower section made of steel, as well as an adapter piece for connecting the two tower sections, characterized in that the adapter piece consists of an annular concrete element and of a steel element, wherein the steel element contains at least one annular flange that fully covers an upper surface of the concrete element in installed position, and that the steel element is directly cast with the concrete element, in which case the annular flange is fully grouted and largely without air inclusions, a microstructure of the concrete element having the highest density on the upper end of the concrete element in installed position.
2. Tower according to claim 1, characterized in that the adapter piece contains an inner annular concrete element and an outer annular steel element, which in its upper end in installation position has an annular flange pointing inwards that covers the upper surface of the concrete element in installation position.
3. Tower according to any one of claims 1 to 2, characterized in that the flange has over its external circumference numerous bore holes, through which fastening elements are inserted for fixing the tower section made of steel in place.
4. Tower according to claim 3, wherein the fastening elements are anchoring bolts.
5. Tower according to any one of claims 1 to 4, characterized in that the flange has numerous openings through which pre-stressing tendons for bracing the tower section made of concrete can be inserted and can be fastened on the upper side of the flange.
6. Tower according to claim 5, wherein the numerous openings in the flange are distributed over its inner circumference.
7. Tower according to any one of claims 1 to 6, characterized in that the steel element has a largely U-shaped cross-section and encompasses an upper area of the concrete element in installation position.
8. Tower according to any one of claims 1 to 7, characterized in that the adapter piece is executed as prefabricated part.
9. Tower according to any one of claims 1 to 8, characterized in that numerous anchoring bolts are poured in the concrete element of the adapter piece on which the tower section made of steel can be fixed in place.
10. Tower according to claim 9, wherein the anchoring bolts are oriented perpendicularly in installed position.
11. Tower according to any one of claims 1 to 10, characterized in that the anchoring bolts protrude through the flange of the steel element over the upper side of the flange.
12. Tower according to any one of claims 1 to 11, characterized in that at least one lower surface of the adapter piece in installation position is smoothed or milled.
13. Tower according to any one of claims 1 to 12, characterized in that the concrete element of the adapter piece is made of high-performance concrete.

14. Tower according to claim 13, wherein the high-performance concrete is concrete of C 50/60 or higher quality.
15. Tower according to claim 5, characterized in that the pre-stressing tendons can be fastened without anchoring plates directly onto the flange of the steel element.
16. Tower according to any one of claims 1-15, characterized in that the lower tower section is executed from annular prefabricated concrete parts, which are braced dry against one another.
17. Tower according to claim 16, characterized in that the annular prefabricated concrete parts are braced with the help of external pre-stressing tendons running inside the tower, in which case at least two pre-stressing tendons extend between one foot section of the tower and the adapter piece.
18. Tower according to any one of claims 16 and 17, characterized in that a horizontal contact joint is sealed between the annular prefabricated concrete parts by means of a sealing profile, wherein the prefabricated concrete parts have a groove for the sealing profile.
19. Tower according to claim 18, characterized in that the horizontal contact joint is additionally sealed with an epoxy resin.
20. Tower according to any one of claims 16 to 19, characterized in that the annular prefabricated concrete parts consist of two or several ring segments, in which case a vertical contact joint is executed dry between the contact surfaces of the ring segments.
21. Tower according to claim 20, characterized in that the ring segments are pre-stressed in horizontal direction by means of diagonally arranged tensioning elements.
22. Tower according to claim 21, wherein the diagonally arranged tensioning elements, are screws.
23. Tower according to any one of claims 16 to 22, characterized in that the prefabricated concrete parts have on their contact surfaces at least one recess in which an element for securing the position and preventing torsion can be inserted.
24. Tower according to claim 23, wherein the at least one recess is at least one bore hole and the element for securing the position and preventing torsion is a plastic dowel.
25. Tower according to any one of claims 1 to 24, characterized in that the tower is a wind power plant tower.
26. Method for building a tower in which a lower tower section made of concrete and an upper tower section made of steel are connected with an adapter piece, characterized in that for manufacturing the adapter piece, a steel element is provided that has at least one annular flange so the steel element is inserted headlong in an annular formwork and afterwards concrete is placed in the formwork in order to make an annular concrete element of the adapter piece, in which case the concrete is directly applied on the later underside of the flange.

27. Method according to claim 26, characterized in that the steel element is at least partially utilized as formwork for the inner concrete element.
28. Method according to any one of claims 26 to 27, characterized in that the adapter piece is made as prefabricated part independently from the manufacturing of the tower sections.
29. Method according to any one of claims 26 to 28, characterized in that at least one lower surface of the adapter piece in installation position is smoothed or milled after the concrete has hardened.
30. Method according to claim 29, wherein the at least one lower surface is parallel to the upper surface of the flange in installation position.
31. Method according to any one of claims 26 to 30, characterized in that the lower tower section is made of annular prefabricated concrete parts, wherein in each case at least one of the horizontal contact surfaces of the prefabricated concrete parts is processed for removing material.
32. Method according to claim 31, wherein the at least one of the horizontal contact surfaces of the prefabricated concrete parts is smoothed or milled.
33. Method according to any one of claims 31 and 32, characterized in that both horizontal contact surfaces of the prefabricated concrete parts are machined in a clamping fixture, in which case the annular prefabricated concrete parts are turned around their axis during processing.
34. Method according to any one of claims 26 to 33, wherein the method is for building a tower of a wind power plant.
35. Method according to claim 34, characterized in that the lower tower section is made from annular prefabricated concrete parts, which are braced dry against one another while the tower is being assembled.

1 / 4

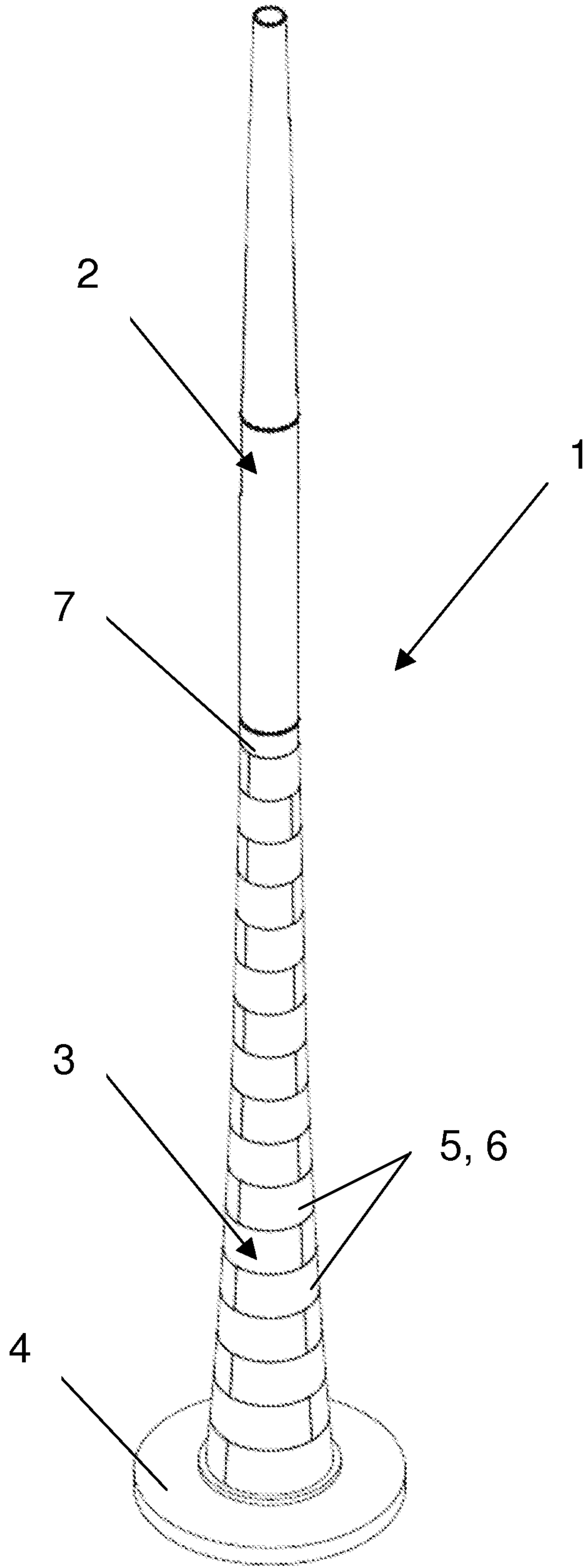

Fig. 1

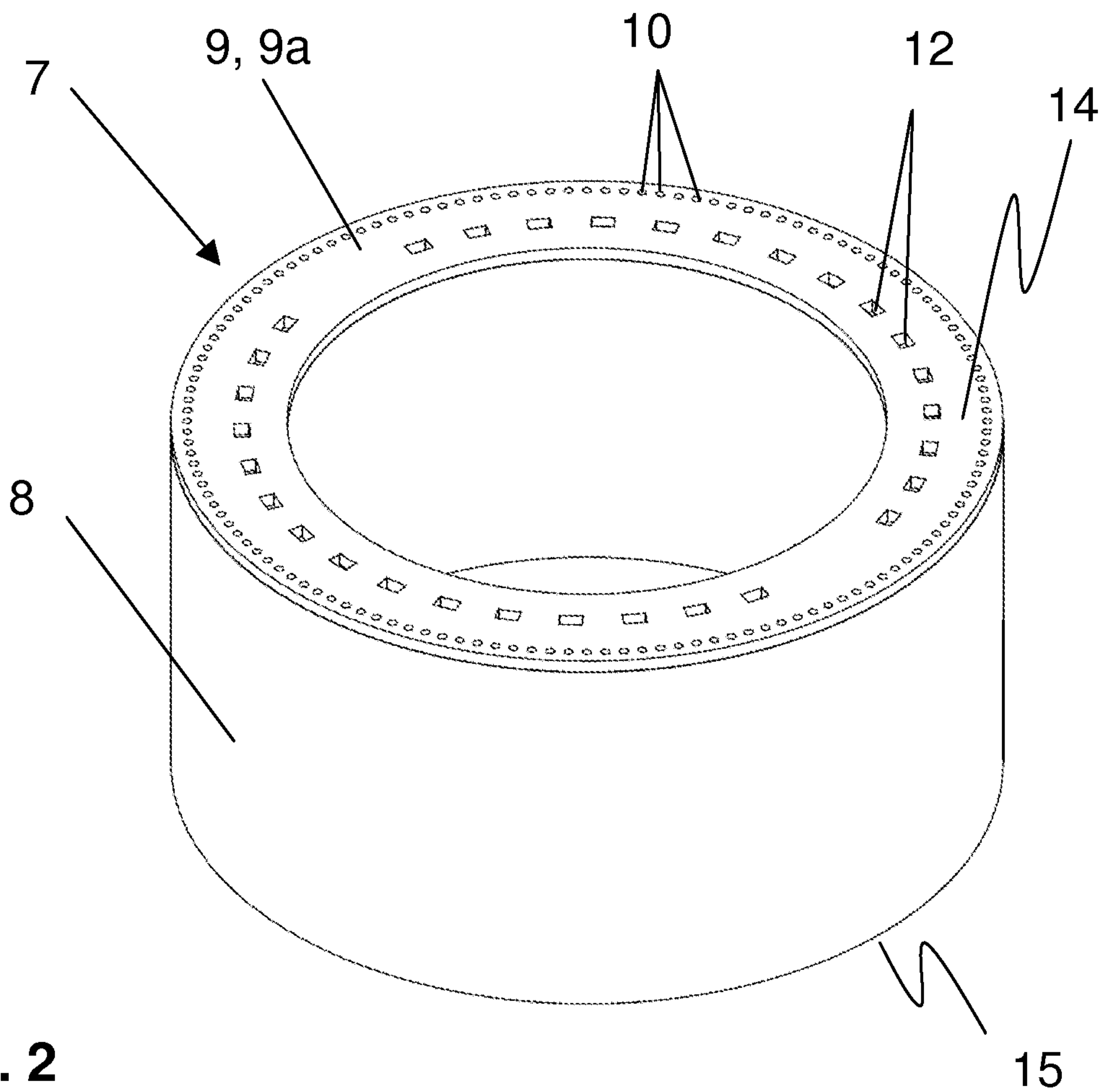

Fig. 2

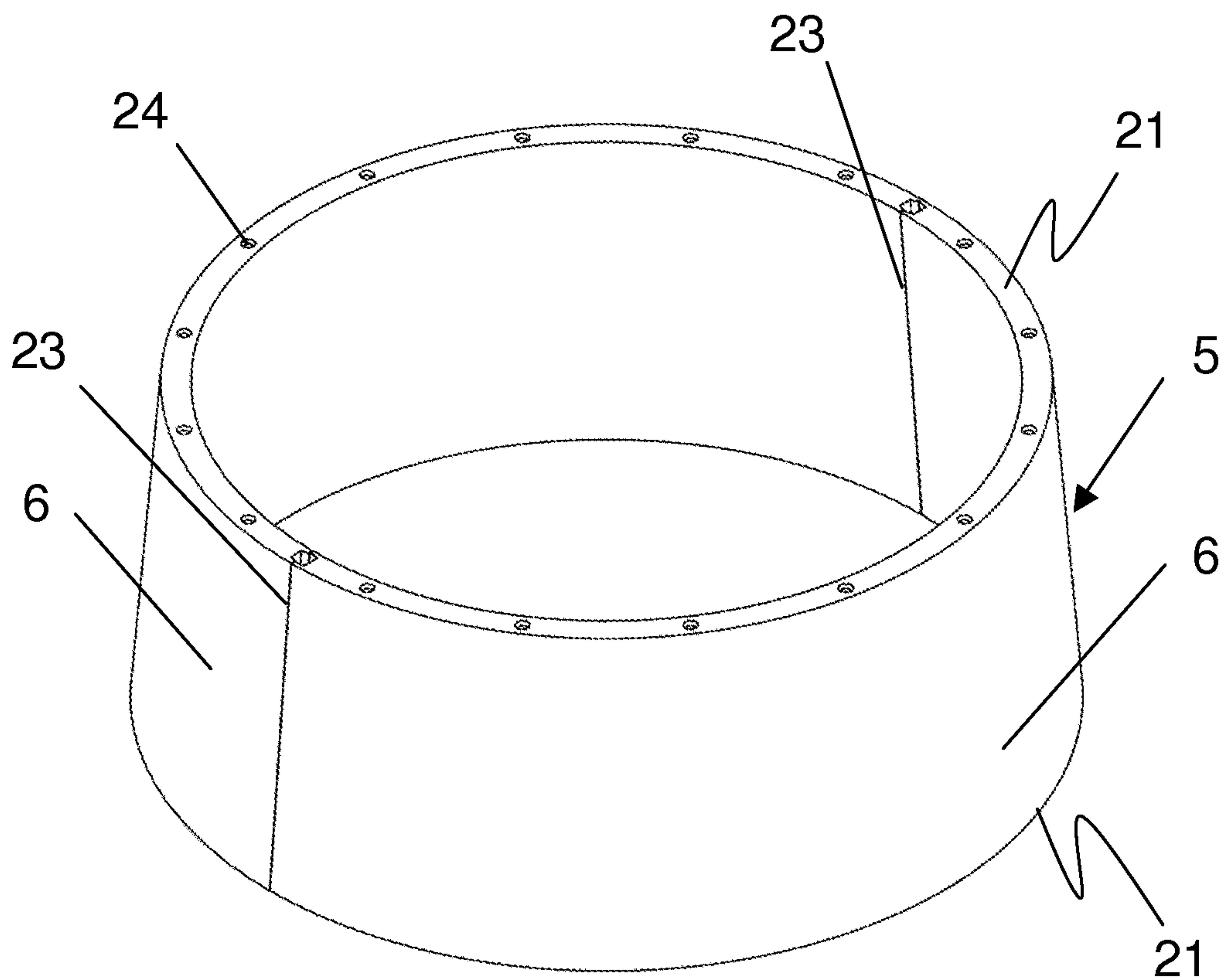

Fig. 4

