

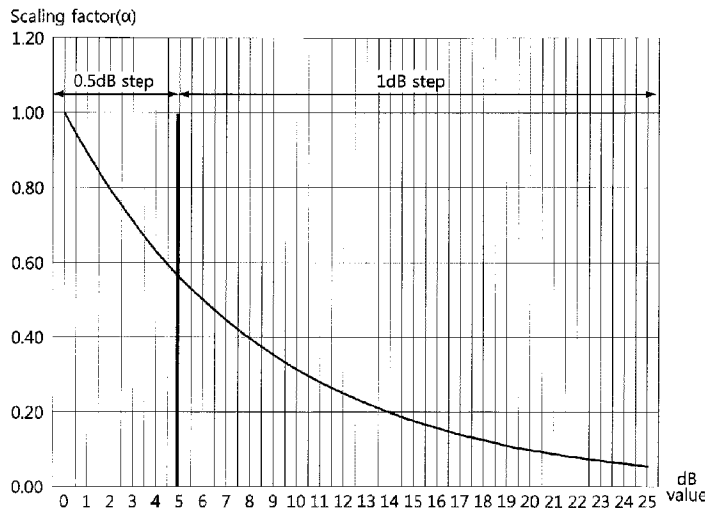

(86) **Date de dépôt PCT/PCT Filing Date:** 2016/11/01
 (87) **Date publication PCT/PCT Publication Date:** 2017/05/11
 (45) **Date de délivrance/Issue Date:** 2020/04/28
 (85) **Entrée phase nationale/National Entry:** 2018/04/10
 (86) **N° demande PCT/PCT Application No.:** KR 2016/012477
 (87) **N° publication PCT/PCT Publication No.:** 2017/078376
 (30) **Priorités/Priorities:** 2015/11/02 (KR10-2015-0153211);
 2015/11/17 (KR10-2015-0160895);
 2016/10/25 (KR10-2016-0139443)

(51) **Cl.Int./Int.Cl. H04L 1/00** (2006.01)
 (72) **Inventeurs/Inventors:**
 PARK, SUNG-IK, KR;
 LEE, JAE-YOUNG, KR;
 KWON, SUN-HYOUNG, KR;
 KIM, HEUNG-MOOK, KR
 (73) **Propriétaire/Owner:**
 ELECTRONICS AND TELECOMMUNICATIONS
 RESEARCH INSTITUTE, KR
 (74) **Agent:** SMART & BIGGAR LLP

(54) **Titre : APPAREIL ET PROCÉDE POUR GÉNÉRER UNE TRAME DE SIGNAL DE DIFFUSION QUI COMPREND UN PREAMBULE AFIN DE SIGNALER DES INFORMATIONS DE NIVEAU D'INJECTION**
 (54) **Title: APPARATUS AND METHOD FOR GENERATING BROADCASTING SIGNAL FRAME THAT INCLUDES PREAMBLE FOR SIGNALLING INJECTION LEVEL INFORMATION**



(57) **Abrégé/Abstract:**

An apparatus and method for generating a broadcast signal frame including preamble for signaling injection level information. An apparatus for generating broadcast signal frame according to an embodiment of the present invention includes an injection level controller configured to generate a power reduced enhanced layer signal by reducing a power of an enhanced layer signal; a combiner configured to generate a multiplexed signal by combining a core layer signal and the power reduced enhanced layer signal; a power normalizer configured to reduce the power of the multiplexed signal to a power level corresponding to the core layer signal; a time interleaver configured to generate a time-interleaved signal by performing interleaving that is applied to both the core layer signal and the enhanced layer signal; and a frame builder configured to generate a broadcast signal frame including a preamble for signaling injection level information corresponding to the injection level controller.

ABSTRACT

An apparatus and method for generating a broadcast signal frame including preamble for signaling injection level information. An apparatus for generating broadcast signal frame according to an embodiment of the present invention includes an injection level controller configured to generate a power reduced enhanced layer signal by reducing a power of an enhanced layer signal; a combiner configured to generate a multiplexed signal by combining a core layer signal and the power reduced enhanced layer signal; a power normalizer configured to reduce the power of the multiplexed signal to a power level corresponding to the core layer signal; a time interleaver configured to generate a time-interleaved signal by performing interleaving that is applied to both the core layer signal and the enhanced layer signal; and a frame builder configured to generate a broadcast signal frame including a preamble for signaling injection level information corresponding to the injection level controller.

15

DESCRIPTION

APPARATUS AND METHOD FOR GENERATING BROADCASTING SIGNAL FRAME THAT INCLUDES PREAMBLE FOR SIGNALLING INJECTION LEVEL INFORMATION

5

Technical Field

[0001] The present invention relates to broadcast signal transmission/reception technology that is used in a broadcasting system and, more particularly, to a broadcast signal transmission/reception system that multiplexes/demultiplexes and then transmits/receives two or more signals.

10

Background Art

[0002] Bit-Interleaved Coded Modulation (BICM) is bandwidth-efficient transmission technology, and is implemented in such a manner that an error-correction coder, a bit-by-bit interleaver and a high-order modulator are combined with one another.

15

[0003] BICM can provide excellent performance using a simple structure because it uses a low-density parity check (LDPC) coder or a Turbo coder as the error-correction coder. Furthermore, BICM can provide high-level flexibility because it can select modulation order and the length and code rate of an error correction code in various forms. Due to these advantages, BICM has been used in broadcasting standards, such as DVB-T2 and DVB-NGH, and has a strong possibility of being used in other next-generation broadcasting systems.

20

[0004] To support multiple services at the same time, multiplexing, i.e., the process of mixing a plurality of signals, is required. Of multiplexing techniques, currently widely used techniques include Time Division Multiplexing (TDM) adapted to divide and use time resources and Frequency Division Multiplexing (FDM) adapted to divide and use frequency resources. That is, TDM is a method of assigning time segments to respective services, and FDM is a technique for assigning frequency resource segments to respective services and then using them. Recently, there is an urgent need for new multiplexing technology that is applicable to a next generation broadcasting system and provides greater flexibility and performance than TDM and FDM.

25

30

Disclosure**Technical Problem**

5 [0005] An object of the present invention is to provide a broadcast signal frame structure in which new signal multiplexing technologies capable of providing greater flexibility and performance than TDM and FDM are applied.

10 [0006] Furthermore, an object of the present invention is to enable a broadcast signal frame for the broadcast signal in which the Layered Division Multiplexing is applied, to efficiently signal the injection level information by using different step sizes in consideration of the amount of change of the scaling factor.

[0007] Furthermore, an object of the present invention is to signal injection level information in consideration of various service environments such as local service.

Technical Solution

15 [0008] In order to accomplish the above objects, the present invention provides an apparatus for generating broadcast signal frame, including: an injection level controller configured to generate a power reduced enhanced layer signal by reducing a power of an enhanced layer signal; a combiner configured to generate a multiplexed signal by combining a core layer signal and the power reduced enhanced layer signal; a power normalizer configured to reduce the power of the multiplexed signal to a power level corresponding to the core layer signal; a time interleaver configured to generate a time-interleaved signal by performing interleaving that is applied to both the core layer signal and the enhanced layer signal; and a frame builder configured to generate a broadcast signal frame including a preamble for signaling injection level information corresponding to the injection level controller.

20

25

[0009] In this case, the injection level information may be signaled by using 31 values which are identified using a 5 bit-field.

30 [0010] In this case, the power normalizer may correspond to a normalizing factor which increases as a power reduction corresponding to the injection level controller becomes larger, and the injection level controller may correspond to a scaling factor which decreases as the power reduction corresponding to the injection level controller becomes larger.

35 [0011] In this case, the 31 values may be matched with 5 bit field values belonging to any one of a first section corresponding to a first step size and a

second section corresponding to a second step size, the second step size being different from the first step size.

5 [0012] In this case, the first section may correspond to a first rate of change of the scaling factor and the second section may correspond to a second rate of change of the scaling factor, the second rate of change being less than the first rate of change.

[0013] In this case, the first section may correspond to a section from 0 dB to 5 dB and the second section may correspond to a section from 6 dB to 25 dB.

10 [0014] In this case, the first step size may be 0.5 dB and the second step size may be 1 dB.

[0015] In this case, the first section may include 5 bit-field values belonging to a section of 0 dB (inclusive) ~ 3 dB (exclusive) and the second section may include 5 bit-field values belonging to a section of 10 dB (exclusive) ~ 25 dB (inclusive).

15 [0016] In this case, the preamble may include layer identification information for identifying layers corresponding to a hierarchical division.

[0017] In this case, the preamble may selectively include the injection level information according to a result of comparing the layer identification information with a predetermined value for each of Physical Layer Pipes (PLPs).

20 [0018] Furthermore, an embodiment of the present invention provides a method of generating broadcast signal frame, including: generating a power reduced enhanced layer signal by reducing a power of an enhanced layer signal; generating a multiplexed signal by combining a core layer signal and the power reduced enhanced layer signal; reducing the power of the multiplexed signal to a power level corresponding to the core layer signal; generating a time-interleaved signal by performing interleaving that is applied to both the core layer signal and the enhanced layer signal; and generating a broadcast signal frame including a preamble for signaling injection level information corresponding to the power reduced enhanced layer signal.

30 [0019] In this case, the injection level information may be signaled by using 31 values which are identified using a 5 bit-field.

[0020] In this case, the reducing power of the multiplexed signal may correspond to a normalizing factor which increases as a power reduction corresponding to the power reduced enhanced layer signal becomes larger, and the generating the power reduced enhanced layer signal may correspond to a scaling factor which decreases as the power reduction corresponding to the power reduced enhanced layer signal becomes larger.

[0021] In this case, wherein the 31 values may be matched with 5 bit field values belonging to any one of a first section corresponding to a first step size and a second section corresponding to a second step size, the second step size being different from the first step size.

5 [0022] In this case, the first section may correspond to a first rate of change of the scaling factor and the second section may correspond to a second rate of change of the scaling factor, the second rate of change being less than the first rate of change.

10 [0023] In this case, the first section may correspond to a section from 0 dB to 5 dB and the second section may correspond to a section from 6 dB to 25 dB.

[0024] In this case, the first step size may be 0.5 dB and the second step size may be 1 dB.

15 [0025] In this case, the first section may include 5 bit-field values belonging to a section of 0 dB (inclusive) ~ 3 dB (exclusive) and the second section may include 5 bit-field values belonging to a section of 10 dB (exclusive) ~ 25 dB (inclusive).

[0026] In this case, the preamble may include layer identification information for identifying layers corresponding to a hierarchical division.

20 [0027] In this case, the preamble may selectively include the injection level information according to a result of comparing the layer identification information with a predetermined value for each of Physical Layer Pipes (PLPs).

Advantageous Effects

25 [0028] According to the present invention, a frame structure in which new signal multiplexing technologies capable of providing greater flexibility and performance than TDM and FDM is provided.

[0029] Furthermore, according to the present invention, a broadcast signal frame for the broadcast signal in which the Layered Division Multiplexing is applied can efficiently signal the injection level information by using different step sizes in consideration of the amount of change of the scaling factor.

30 [0030] Furthermore, according to the present invention, injection level information can be signaled in consideration of various service environments such as local service.

Description of Drawings

[0031] FIG. 1 is a block diagram showing a broadcast signal transmission/reception system according to an embodiment of the present invention;

5 [0032] FIG. 2 is an operation flowchart showing a broadcast signal transmission/reception method according to an embodiment of the present invention;

[0033] FIG. 3 is a block diagram showing an example of the apparatus for generating broadcast signal frame in FIG. 1;

10 [0034] FIG. 4 is a diagram showing an example of the structure of a broadcast signal frame;

[0035] FIG. 5 is a diagram showing an example of the receiving process of the broadcast signal frame shown in FIG. 4;

[0036] FIG. 6 is a diagram showing another example of the receiving process of the broadcast signal frame shown in FIG. 4;

15 [0037] FIG. 7 is a block diagram showing another example of the apparatus for generating broadcast signal frame shown in FIG. 1;

[0038] FIG. 8 is a block diagram showing an example of the signal demultiplexer shown in FIG. 1;

20 [0039] FIG. 9 is a block diagram showing an example of the core layer BICM decoder and the enhanced layer symbol extractor shown in FIG. 8;

[0040] FIG. 10 is a block diagram showing another example of the core layer BICM decoder and the enhanced layer symbol extractor shown in FIG. 8;

[0041] FIG. 11 is a block diagram showing still another example of the core layer BICM decoder and the enhanced layer symbol extractor shown in FIG. 8;

25 [0042] FIG. 12 is a block diagram showing another example of the signal demultiplexer shown in FIG. 1;

[0043] FIG. 13 is a diagram showing an increase in power attributable to the combination of a core layer signal and an enhanced layer signal;

30 [0044] FIG. 14 is an operation flowchart showing a method of generating broadcast signal frame according to an embodiment of the present invention;

[0045] FIG. 15 is a diagram showing a structure of a super-frame which includes broadcast signal frames according to an embodiment of the present invention;

35 [0046] FIG. 16 is a diagram showing an example of a LDM frame including multiple-physical layer pipes and using LDM of two layers;

[0047] FIG. 17 is a diagram showing another example of a LDM frame including multiple-physical layer pipes and using LDM of two layers;

- [0048] FIG. 18 is a diagram showing an application example of a LDM frame using multiple-physical layer pipes and LDM of two layers;
- [0049] FIG. 19 is a diagram showing another application example of a LDM frame using multiple-physical layer pipes and LDM of two layers;
- 5 [0050] FIG. 20 is a diagram showing an example in which a convolutional time interleaver is used;
- [0051] FIG. 21 is a diagram showing another example in which a convolutional time interleaver is used;
- [0052] FIG. 22 is a diagram showing an example in which a hybrid time interleaver is used;
- 10 [0053] FIG. 23 is a diagram showing time interleaver groups in the example of FIG. 22;
- [0054] FIGS 24-26 are diagrams showing a process for calculating a size of the incomplete FEC block in the example of FIG. 23;
- 15 [0055] FIG. 27 is a diagram for explaining the number of bits required for L1D_plp_fec_block_start when L1D_plp_TI_mode = "00" ;
- [0056] FIGS. 28 and 29 are diagrams for explaining the number of bits required for L1D_plp_CTI_fec_block_start when L1D_plp_TI_mode="01";
- [0057] FIG. 30 is a diagram showing a core layer signal and an enhanced layer signal in case of the example of Table 4;
- 20 [0058] FIG. 31 is a diagram showing a core layer signal and an enhanced layer signal in case of the example of Table 5;
- [0059] FIG. 32 is a diagram showing a core layer signal and an enhanced layer signal in case of the example of Table 6; and
- 25 [0060] FIG. 33 is a graph showing a scaling factor according to the change of the LDM injection level value (dB).

Mode for Invention

- [0061] The present invention will be described in detail below with reference to the accompanying drawings. In the description, redundant descriptions and descriptions of well-known functions and configurations that
- 30 have been deemed to make the gist of the present invention unnecessarily obscure will be omitted below. The embodiments of the present invention are provided to fully describe the present invention to persons having ordinary knowledge in the art to which the present invention pertains. Accordingly, the shapes, sizes, etc. of components in the drawings may be exaggerated to make the description
- 35 obvious.

[0062] Preferred embodiments of the present invention are described in detail below with reference to the accompanying drawings.

5 [0063] FIG. 1 is a block diagram showing a broadcast signal transmission/reception system according to an embodiment of the present invention.

[0064] Referring to FIG. 1, a broadcast signal transmission/reception system according to the embodiment of the present invention includes a broadcast signal transmission apparatus 110, a wireless channel 120, and a broadcast signal reception apparatus 130.

10 [0065] The broadcast signal transmission apparatus 110 includes an apparatus for generating broadcast signal frame 111 which generate the broadcast signal frame by multiplexing core layer data and enhanced layer data, and an OFDM transmitter 113.

15 [0066] The apparatus 111 combines a core layer signal corresponding to core layer data and an enhanced layer signal corresponding to enhanced layer data at different power levels, and generates a multiplexed signal by performing interleaving that is applied to both the core layer signal and the enhanced layer signal. In this case, the apparatus 111 may generate a broadcast signal frame including a bootstrap and a preamble using a time-interleaved signal. In this case, the broadcast signal frame may be an ATSC 3.0 frame.

20 [0067] In this case, the time interleaving may use one of time interleaver groups, and a boundary between the time interleaver groups may be a boundary between Physical Layer Pipes (PLPs) of a core layer corresponding to the core layer signal. That is, one of the boundaries between the Physical Layer Pipes of the core layer may be the boundary between the time interleaver groups.

[0068] The OFDM transmitter 113 transmits the multiplexed signal using an OFDM communication method via an antenna 117, thereby allowing the transmitted OFDM signal to be received via the antenna 137 of the broadcast signal reception apparatus 130 over the wireless channel 120.

30 [0069] The broadcast signal reception apparatus 130 includes an OFDM receiver 133 and a signal demultiplexer 131. When the signal transmitted over the wireless channel 120 is received via the antenna 137, the OFDM receiver 133 receives an OFDM signal via synchronization, channel estimation and equalization.

35 [0070] In this case, the OFDM receiver 133 may detect and demodulate the bootstrap from the OFDM signal, demodulate the preamble using information

included in the bootstrap, and demodulate the super-imposed payload using information included in the preamble.

5 [0071] The signal demultiplexer 131 restores the core layer data from the signal (super-imposed payload) received via the OFDM receiver 133 first, and then restores the enhanced layer data via cancellation corresponding to the restored core layer data. In this case, the signal demultiplexer 131 may generate a broadcast signal frame first, may restore the bootstrap, may restore the preamble using the information included in the bootstrap, and may use the signaling information included in the preamble for the restoration of a data signal. In this case, the signaling information may be L1 signaling information and may include injection level information, normalizing factor information, etc.

10 [0072] In this case, the preamble may include a PLP identification information for identifying Physical Layer Pipes (PLPs); and a layer identification information for identifying layers corresponding to division of layers.

15 [0073] In this case, the PLP identification information and the layer identification information may be included in the preamble as fields different from each other.

20 [0074] In this case, the time interleaver information may be included in the preamble on the basis of the core layer.

[0075] In this case, the preamble may selectively include an injection level information corresponding to the injection level controller for each of the Physical Layer Pipes (PLPs) based on a result of comparing the layer identification information with a predetermined value.

25 [0076] In this case, the injection level information may be signaled by using 31 values which are identified using a 5 bit-field.

[0077] In this case, the power normalizer may correspond to a normalizing factor which increases as a power reduction corresponding to the injection level controller becomes larger, and the injection level controller may correspond to a scaling factor which decreases as the power reduction corresponding to the injection level controller becomes larger.

30 [0078] In this case, the 31 values may be matched with 5 bit field values belonging to any one of a first section corresponding to a first step size and a second section corresponding to a second step size, the second step size being different from the first step size.

35 [0079] In this case, the first section may correspond to a first rate of change of the scaling factor and the second section may correspond to a second rate of

change of the scaling factor, the second rate of change being less than the first rate of change.

[0080] In this case, the first section may correspond to a section from 0 dB to 5 dB and the second section may correspond to a section from 6 dB to 25 dB.

5 **[0081]** In this case, the first step size may be 0.5 dB and the second step size may be 1 dB.

[0082] In this case, the first section may include 5 bit-field values belonging to a section of 0 dB (inclusive) ~ 3 dB (exclusive) and the second section may include 5 bit-field values belonging to a section of 10 dB (exclusive) ~ 25 dB
10 (inclusive).

[0083] In this case, the preamble may include layer identification information for identifying layers corresponding to a hierarchical division.

[0084] In this case, the preamble may selectively include the injection level information according to a result of comparing the layer identification
15 information with a predetermined value for each of Physical Layer Pipes (PLPs).

[0085] In this case, the preamble may include type information, start position information and size information of the Physical Layer Pipes

[0086] In this case, the type information may be for identifying one among
20 a first type corresponding to a non-dispersed physical layer pipe and a second type corresponding to a dispersed physical layer pipe.

[0087] In this case, the non-dispersed physical layer pipe may be assigned for contiguous data cell indices, and the dispersed physical layer pipe may include two or more subslices.

[0088] In this case, the type information may be selectively signaled according to a result of comparing the layer identification information with a
25 predetermined value for each of the Physical Layer Pipes (PLPs).

[0089] In this case, the type information may be signaled only for the core layer.

[0090] In this case, the start position information may be identical to an
30 index corresponding to the first data cell of the physical layer pipe.

[0091] In this case, the start position information may indicate the start position of the physical layer pipe using cell addressing scheme.

[0092] In this case, the start position information may be included in the preamble for each of the Physical Layer Pipes (PLPs) without checking a
35 condition of a conditional statement corresponding to the layer identification information.

[0093] In this case, the size information may be generated based on the number of data cells assigned to the physical layer pipe.

[0094] In this case, the size information may be included in the preamble for each of the Physical Layer Pipes (PLPs) without checking a condition of a conditional statement corresponding to the layer identification information.

[0095] In this case, the time interleaver information may be signaled on the basis of the core layer.

[0096] In this case, the time interleaver may correspond to a hybrid time interleaver. In this case, Physical Layer Pipes (PLPs) of a core layer and an enhanced layer may include only complete FEC blocks.

[0097] In this case, the preamble may be for signaling information for identifying a part of a FEC block in the enhanced layer in case that the boundary between the time interleaver groups does not correspond to a boundary between FEC blocks in the enhanced layer, the FEC block corresponding to the boundary between the time interleaver groups.

[0098] In this case, the information for identifying the part of the FEC block may include at least one of start position information of a Physical Layer Pipe (PLP) in the core layer, start position information of a Physical Layer Pipe (PLP) in the enhanced layer, modulation information corresponding to the enhanced layer, and FEC type information corresponding to the enhanced layer.

[0099] In this case, the start position information of the Physical Layer Pipe (PLP) may correspond to an index of a first data cell of the Physical Layer Pipe (PLP).

[00100] In this case, the modulation information may be signaled only if the FEC type information satisfies a predetermined condition.

[00101] In this case, the enhanced layer signal may correspond to enhanced layer data that is restored based on cancellation corresponding to restoration of core layer data corresponding to the core layer signal.

[00102] In this case, the time interleaver may correspond to a convolutional time interleaver, the time interleaver groups may include the Physical Layer Pipe (PLP) which includes an incomplete FEC block, and the preamble may be for signaling start position information of a first complete FEC block in the Physical Layer Pipe (PLP).

[00103] In this case, the time interleaver may perform the interleaving by using one of a plurality of operation modes.

[00104] In this case, the operation modes may include a first mode corresponding to no time interleaving, a second mode for performing a

Convolutional time interleaving and a third mode for performing a Hybrid time interleaving.

5 [00105] In this case, the preamble may include a field indicating a start position of a first complete FEC block corresponding to a current Physical Layer Pipe for the first mode and the second mode, and may not include the field indicating the start position of the first FEC block for the third mode. In this case, the field indicating the start position may indicate the start position of the first FEC block starting in a current Physical Layer Pipe during a current subframe.

10 [00106] In this case, the field indicating the start position of the first FEC block may be one of a first field used in the first mode and a second field used in the second mode, and the first field and the second field may have different lengths.

15 [00107] In this case, the length of the second field may be longer than the length of the first field.

[00108] In this case, the length of the first field may be determined based on a length of a LDPC codeword and a modulation order and the length of the second field may be determined not only by the length of the LDPC codeword and the modulation order but also by further considering a depth of a Convolutional time interleaver.

20

[00109] In this case, the length of the first field may be 15 bits and the length of the second field may be 22 bits.

[00110] In this case, the first field and the second field may be separately signaled for each of a core layer corresponding to the core layer signal and an enhanced layer corresponding to the enhanced layer signal.

25

[00111] As will be described in detail later, the apparatus 111 shown in FIG. 1 may include an injection level controller configured to generate a power reduced enhanced layer signal by reducing a power of an enhanced layer signal; a combiner configured to generate a multiplexed signal by combining a core layer signal and the power reduced enhanced layer signal; a power normalizer configured to reduce the power of the multiplexed signal to a power level corresponding to the core layer signal; a time interleaver configured to generate a time-interleaved signal by performing interleaving that is applied to both the core layer signal and the enhanced layer signal; and a frame builder configured to generate a broadcast signal frame including a preamble for signaling injection level information corresponding to the injection level controller. In this case, the time interleaver may perform the interleaving by using one of a plurality of

30

35

operation modes. In this case, the broadcast signal transmission apparatus 110 shown in FIG. 1 may be viewed as including: an injection level controller configured to generate a power reduced enhanced layer signal by reducing a power of an enhanced layer signal; a combiner configured to generate a multiplexed signal by combining a core layer signal and the power reduced enhanced layer signal; a power normalizer configured to reduce the power of the multiplexed signal to a power level corresponding to the core layer signal; a time interleaver configured to generate a time-interleaved signal by performing interleaving that is applied to both the core layer signal and the enhanced layer signal; a frame builder configured to generate a broadcast signal frame including a preamble for signaling injection level information corresponding to the injection level controller; and an OFDM transmitter configured to transmit the broadcast signal frame using OFDM communication scheme through an antenna. In this case, the time interleaver may perform the interleaving by using one of a plurality of operation modes.

[00112] As will be described in detail later, the signal demultiplexer shown in FIG. 1 may include a time deinterleaver configured to generate a time-deinterleaved signal by applying time deinterleaving to a received signal corresponding to a broadcast signal frame; a de-normalizer configured to increase the power of the received signal or the time-deinterleaved signal by a level corresponding to a reduction in power by the power normalizer of the transmitter; a core layer BICM decoder configured to restore core layer data from the signal power-adjusted by the de-normalizer; an enhanced layer symbol extractor configured to extract an enhanced layer signal by performing cancellation corresponding to the core layer data on the signal power-adjusted by the de-normalizer using the output signal of the core layer FEC decoder of the core layer BICM decoder; a de-injection level controller configured to increase the power of the enhanced layer signal by a level corresponding to a reduction in power by the injection level controller of the transmitter; and an enhanced layer BICM decoder configured to restore enhanced layer data using the output signal of the de-injection level controller. In this case, the broadcast signal reception apparatus 130 shown in FIG. 1 may be viewed as including: an OFDM receiver configured to generate a received signal by performing any one or more of synchronization, channel estimation and equalization on a transmitted signal corresponding to a broadcast signal frame; a time deinterleaver configured to generate a time-deinterleaved signal by applying time deinterleaving to the received signal; a de-normalizer configured to increase the power of the received signal or the time-

deinterleaved signal by a level corresponding to a reduction in power by the power normalizer of the transmitter; a core layer BICM decoder configured to restore core layer data from the signal power-adjusted by the de-normalizer; an enhanced layer symbol extractor configured to extract an enhanced layer signal by performing cancellation corresponding to the core layer data on the signal power-adjusted by the de-normalizer using the output signal of the core layer FEC decoder of the core layer BICM decoder; a de-injection level controller configured to increase the power of the enhanced layer signal by a level corresponding to a reduction in power by the injection level controller of the transmitter; and an enhanced layer BICM decoder configured to restore enhanced layer data using the output signal of the de-injection level controller.

[00113] In this case, the time deinterleaver may perform the deinterleaving by using one of a plurality of operation modes. That is, the time deinterleaver may be operated corresponding to the time interleaver performing the interleaving by using one of a plurality of operation modes.

[00114] Although not explicitly shown in FIG. 1, a broadcast signal transmission/reception system according to an embodiment of the present invention may multiplex/demultiplex one or more pieces of extension layer data in addition to the core layer data and the enhanced layer data. In this case, the extension layer data may be multiplexed at a power level lower than that of the core layer data and the enhanced layer data. Furthermore, when two or more extension layers are included, the injection power level of a second extension layer may be lower than the injection power level of a first extension layer, and the injection power level of a third extension layer may be lower than the injection power level of the second extension layer.

[00115] FIG. 2 is an operation flowchart showing a broadcast signal transmission/reception method according to an embodiment of the present invention.

[00116] Referring to FIG. 2, in the broadcast signal transmission/reception method according to the embodiment of the present invention, a core layer signal and an enhanced layer signal are combined at different power levels and then multiplexed to generate a broadcast signal frame including time interleaver information shared by the core layer signal and the enhanced layer signal and a preamble for signaling the time interleaver information at step S210.

[00117] In this case, the broadcast signal frame generated at step S210 may include the bootstrap, the preamble and a super-imposed payload. In this case, at least of the bootstrap and the preamble may include L1 signaling information.

In this case, the L1 signaling information may include injection level information and normalizing factor information.

[00118] In this case, the injection level information may be signaled by using 31 values which are identified using a 5 bit-field.

5 **[00119]** In this case, the reducing power of the multiplexed signal may correspond to a normalizing factor which increases as a power reduction corresponding to the power reduced enhanced layer signal becomes larger, and the generating the power reduced enhanced layer signal may correspond to a scaling factor which decreases as the power reduction corresponding to the power reduced enhanced layer signal becomes larger.

10 **[00120]** In this case, wherein the 31 values may be matched with 5 bit field values belonging to any one of a first section corresponding to a first step size and a second section corresponding to a second step size, the second step size being different from the first step size.

15 **[00121]** In this case, the first section may correspond to a first rate of change of the scaling factor and the second section may correspond to a second rate of change of the scaling factor, the second rate of change being less than the first rate of change.

20 **[00122]** In this case, the first section may correspond to a section from 0 dB to 5 dB and the second section may correspond to a section from 6 dB to 25 dB.

[00123] In this case, the first step size may be 0.5 dB and the second step size may be 1 dB.

25 **[00124]** In this case, the first section may include 5 bit-field values belonging to a section of 0 dB (inclusive) ~ 3 dB (exclusive) and the second section may include 5 bit-field values belonging to a section of 10 dB (exclusive) ~ 25 dB (inclusive).

[00125] In this case, the preamble may include layer identification information for identifying layers corresponding to a hierarchical division.

30 **[00126]** In this case, the preamble may selectively include the injection level information according to a result of comparing the layer identification information with a predetermined value for each of Physical Layer Pipes (PLPs).

35 **[00127]** In this case, the preamble may include a PLP identification information for identifying Physical Layer Pipes (PLPs); and a layer identification information for identifying layers corresponding to division of layers.

[00128] In this case, the PLP identification information and the layer identification information may be included in the preamble as fields different from each other.

5 **[00129]** In this case, the time interleaver information may be included in the preamble on the basis of a core layer.

[00130] In this case, the preamble may selectively include an injection level information corresponding to the injection level controller for each of the Physical Layer Pipes (PLPs) based on a result of comparing the layer identification information with a predetermined value.

10 **[00131]** In this case, the preamble may include type information, start position information and size information of the Physical Layer Pipes

[00132] In this case, the type information may be for identifying one among a first type corresponding to a non-dispersed physical layer pipe and a second type corresponding to a dispersed physical layer pipe.

15 **[00133]** In this case, the non-dispersed physical layer pipe may be assigned for contiguous data cell indices, and the dispersed physical layer pipe may include two or more subslices.

[00134] In this case, the type information may be selectively signaled according to a result of comparing the layer identification information with a predetermined value for each of the Physical Layer Pipes (PLPs).

20 **[00135]** In this case, the type information may be signaled only for the core layer.

[00136] In this case, the start position information may be identical to an index corresponding to the first data cell of the physical layer pipe.

25 **[00137]** In this case, the start position information may indicate the start position of the physical layer pipe using cell addressing scheme.

[00138] In this case, the start position information may be included in the preamble for each of the Physical Layer Pipes (PLPs) without checking a condition of a conditional statement corresponding to the layer identification information.

30 **[00139]** In this case, the size information may be generated based on the number of data cells assigned to the physical layer pipe.

[00140] In this case, the size information may be included in the preamble for each of the Physical Layer Pipes (PLPs) without checking a condition of a conditional statement corresponding to the layer identification information.

35 **[00141]** In this case, the time interleaver information may be signaled on the basis of the core layer.

[00142] In this case, the generating the time-interleaved signal may use a hybrid time interleaver for performing the interleaving.

[00143] In this case, the Physical Layer Pipes (PLPs) of a core layer and an enhanced layer may include only complete FEC blocks.

5 **[00144]** In this case, the preamble may be for signaling information for identifying a part of a FEC block of the enhanced layer in case that the boundary between the time interleaver groups does not correspond to a boundary between FEC blocks of the enhanced layer, the FEC block corresponding to the boundary between the time interleaver groups.

10 **[00145]** In this case, the information for identifying the part of the FEC block may include at least one of start position information of a Physical Layer Pipe (PLP) in the core layer, start position information of a Physical Layer Pipe (PLP) in the enhanced layer, modulation information corresponding to the enhanced layer, and FEC type information corresponding to the enhanced layer.

15 **[00146]** In this case, the start position information of the Physical Layer Pipe (PLP) may correspond to an index of a first data cell of the Physical Layer Pipe (PLP).

[00147] In this case, the modulation information may be signaled only if the FEC type information satisfies a predetermined condition.

20 **[00148]** In this case, the enhanced layer signal corresponds to enhanced layer data that may be restored based on cancellation corresponding to restoration of core layer data corresponding to the core layer signal.

[00149] In this case, the generating the time-interleaved signal may use a convolutional time interleaver for performing the interleaving, the time interleaver groups may include the Physical Layer Pipe (PLP) which includes an incomplete FEC block, and the preamble may be for signaling start position information of a first complete FEC block in the Physical Layer Pipe (PLP).

25 **[00150]** In this case, the interleaving may be performed by using one of a plurality of operation modes.

30 **[00151]** In this case, the operation modes may include a first mode corresponding to no time interleaving, a second mode for performing a Convolutional time interleaving and a third mode for performing a Hybrid time interleaving.

35 **[00152]** In this case, the preamble may include a field indicating a start position of a first complete FEC block corresponding to a current Physical Layer Pipe for the first mode and the second mode, and may not include the field indicating the start position of the first FEC block for the third mode.

[00153] In this case, the field indicating the start position of the first FEC block may be one of a first field used in the first mode and a second field used in the second mode, and the first field and the second field may have different lengths.

5 [00154] In this case, the length of the second field may be longer than the length of the first field.

[00155] In this case, the length of the first field may be determined based on a length of a LDPC codeword and a modulation order and the length of the second field may be determined not only by the length of the LDPC codeword and the modulation order but also by further considering a depth of a Convolutional time interleaver.

[00156] In this case, the length of the first field may be 15 bits and the length of the second field may be 22 bits.

15 [00157] In this case, the first field and the second field may be separately signaled for each of a core layer corresponding to the core layer signal and an enhanced layer corresponding to the enhanced layer signal.

[00158] Furthermore, in the broadcast signal transmission/reception method according to the embodiment of the present invention, the broadcast signal frame is OFDM transmitted at step S220.

20 [00159] Furthermore, in the broadcast signal transmission/reception method according to the embodiment of the present invention, the transmitted signal is OFDM received at step S230.

[00160] In this case, at step S230, synchronization, channel estimation and equalization may be performed.

25 [00161] In this case, the bootstrap may be restored, the preamble may be restored using a signal included in the restored bootstrap, and the data signal may be restored using the signaling information included in the preamble at step S230.

[00162] Furthermore, in the broadcast signal transmission/reception method according to the embodiment of the present invention, core layer data is restored from the received signal at step S240.

[00163] Furthermore, in the broadcast signal transmission/reception method according to the embodiment of the present invention, enhanced layer data is restored via the cancellation of the core layer signal at step S250.

30 [00164] In particular, steps S240 and S250 shown in FIG. 2 may correspond to demultiplexing operations corresponding to step S210.

[00165] As will be described in detail later, step S210 shown in FIG. 2 may include generating a multiplexed signal by combining a core layer signal and an

enhanced layer signal at different power levels; reducing the power of the multiplexed signal to a power level corresponding to the core layer signal; generating a time-interleaved signal by performing interleaving that is applied to both the core layer signal and the enhanced layer signal; and generating a broadcast signal frame including a preamble for signaling time interleaver information corresponding to the interleaving. In this case, the interleaving may be performed by using one of a plurality of operation modes. In this case, the broadcast signal transmission method of steps S210 and S220 may be viewed as including generating a multiplexed signal by combining a core layer signal and an enhanced layer signal at different power levels; reducing the power of the multiplexed signal to a power level corresponding to the core layer signal; generating a time-interleaved signal by performing interleaving that is applied to both the core layer signal and the enhanced layer signal; generating a broadcast signal frame including a preamble for signaling time interleaver information corresponding to the interleaving; and transmitting the broadcast signal frame using an OFDM communication scheme through an antenna. In this case, the interleaving may be performed by using one of a plurality of operation modes.

[00166] As will be described in detail later, steps S240 and S250 shown in FIG. 2 may include generating a time-deinterleaved signal by applying time deinterleaving to a received signal corresponding to a broadcast signal frame; increasing the power of the received signal or the time-deinterleaved signal by a level corresponding to a reduction in power by the power normalizer of the transmitter; restoring core layer data from the power-adjusted signal; extracting an enhanced layer signal by performing cancellation corresponding to the core layer data on the power-adjusted signal; increasing the power of the enhanced layer signal by a level corresponding to a reduction in power by the injection level controller of the transmitter; and restoring enhanced layer data using the power-adjusted enhanced signal. In this case, a broadcast signal reception method according to an embodiment of the present invention may be viewed as including: generating a received signal by performing any one or more of synchronization, channel estimation and equalization on a transmitted signal corresponding to a broadcast signal frame; generating a time-deinterleaved signal by applying time deinterleaving to the received signal; increasing the power of the received signal or the time-deinterleaved signal by a level corresponding to a reduction in power by the power normalizer of the transmitter; restoring core layer data from the power-adjusted signal; extracting an enhanced layer signal by performing cancellation corresponding to the core layer data on the power-

adjusted signal; increasing the power of the enhanced layer signal by a level corresponding to a reduction in power by the injection level controller of the transmitter; and restoring enhanced layer data using the power-adjusted enhanced layer signal.

5 [00167] In this case, the time deinterleaving may perform the deinterleaving by using one of a plurality of operation modes.

[00168] FIG. 3 is a block diagram showing an example of the apparatus for generating broadcast signal frame in FIG. 1.

10 [00169] Referring to FIG. 3, the apparatus for generating broadcast signal frame according to an embodiment of the present invention may include a core layer BICM unit 310, an enhanced layer BICM unit 320, an injection level controller 330, a combiner 340, a power normalizer 345, and a time interleaver 350, a signaling generation unit 360, and a frame builder 370.

15 [00170] Generally, a BICM device includes an error correction encoder, a bit interleaver, and a symbol mapper. Each of the core layer BICM unit 310 and the enhanced layer BICM unit 320 shown in FIG. 3 may include an error correction encoder, a bit interleaver, and a symbol mapper. In particular, each of the error correction encoders (the core layer FEC encoder, and the enhanced layer FEC encoder) shown in FIG. 3 may be formed by connecting a BCH encoder and an LDPC encoder in series. In this case, the input of the error correction encoder is input to the BCH encoder, the output of the BCH encoder is input to the LDPC encoder, and the output of the LDPC encoder may be the output of the error correction encoder.

20 [00171] As shown in FIG. 3, core layer data and enhanced layer data pass through respective different BICM units, and are then combined by the combiner 340. That is, the term “Layered Division Multiplexing (LDM)” used herein may refer to combining the pieces of data of a plurality of layers into a single piece of data using differences in power and then transmitting the combined data.

25 [00172] That is, the core layer data passes through the core layer BICM unit 310, the enhanced layer data passes through the enhanced layer BICM unit 320 and then the injection level controller 330, and the core layer data and the enhanced layer data are combined by the combiner 340. In this case, the enhanced layer BICM unit 320 may perform BICM encoding different from that of the core layer BICM unit 310. That is, the enhanced layer BICM unit 320 may perform higher bit rate error correction encoding or symbol mapping than
30
35 the core layer BICM unit 310. Furthermore, the enhanced layer BICM unit 320

may perform less robust error correction encoding or symbol mapping than the core layer BICM unit 310.

5 [00173] For example, the core layer error correction encoder may exhibit a lower bit rate than the enhanced layer error correction encoder. In this case, the enhanced layer symbol mapper may be less robust than the core layer symbol mapper.

10 [00174] The combiner 340 may be viewed as functioning to combine the core layer signal and the enhanced layer signal at different power levels. In an embodiment, power level adjustment may be performed on the core layer signal rather than the enhanced layer signal. In this case, the power of the core layer signal may be adjusted to be higher than the power of the enhanced layer signal.

15 [00175] The core layer data may use forward error correction (FEC) code having a low code rate in order to perform robust reception, while the enhanced layer data may use FEC code having a high code rate in order to achieve a high data transmission rate.

[00176] That is, the core layer data may have a broader coverage than the enhanced layer data in the same reception environment.

20 [00177] The enhanced layer data having passed through the enhanced layer BICM unit 320 is adjusted in gain (or power) by the injection level controller 330, and is combined with the core layer data by the combiner 340.

25 [00178] That is, the injection level controller 330 generates a power-reduced enhanced layer signal by reducing the power of the enhanced layer signal. In this case, the magnitude of the signal adjusted by the injection level controller 330 may be determined based on an injection level. In this case, an injection level in the case where signal B is inserted into signal A may be defined by Equation 1 below:

$$\text{Injection level (dB)} = -10 \log_{10} \left(\frac{\text{Signal power of B}}{\text{Signal power of A}} \right) \quad (1)$$

30 [00179] For example, assuming that the injection level is 3 dB when the enhanced layer signal is inserted into the core layer signal, Equation 1 means that the enhanced layer signal has power corresponding to half of the power of the core layer signal.

[00180] In this case, the injection level controller 330 may adjust the power level of the enhanced layer signal from 0 dB to 25.0 dB in steps of 0.5 dB or 1 dB.

[00181] In general, transmission power that is assigned to the core layer is higher than transmission power that is assigned to the enhanced layer, which enables the receiver to decode core layer data first.

5 [00182] In this case, the combiner 340 may be viewed as generating a multiplexed signal by combining the core layer signal with the power-reduced enhanced layer signal.

10 [00183] The signal obtained by the combination of the combiner 340 is provided to the power normalizer 345 so that the power of the signal can be reduced by a power level corresponding to an increase in power caused by the combination of the core layer signal and the enhanced layer signal, and then power adjustment is performed. That is, the power normalizer 345 reduces the power of the signal, obtained by the multiplexing of the combiner 340, to a power level corresponding to the core layer signal. Since the level of the combined signal is higher than the level of one layer signal, the power normalizing of the power normalizer 345 is required in order to prevent amplitude clipping, etc. in the remaining portion of a broadcast signal transmission/reception system.

15 [00184] In this case, the power normalizer 345 may adjust the magnitude of the combined signal to an appropriate value by multiplying the magnitude of the combined signal by the normalizing factor of Equation 2 below. Injection level information used to calculate Equation 2 below may be transferred to the power normalizer 345 via a signaling flow:

$$\text{Normalizing factor} = \left(\sqrt{(1 + 10^{-\text{Injection level (dB)} / 10})} \right)^{-1} \quad (2)$$

20 [00185] Assuming that the power levels of the core layer signal and the enhanced layer signal are normalized to 1 when an enhanced layer signal S_E is injected into a core layer signal S_C at a preset injection level, a combined signal may be expressed by $S_C + \alpha S_E$.

[00186] In this case, α is scaling factors corresponding to various injection levels. That is, the injection level controller 330 may correspond to the scaling factor.

30 [00187] For example, when the injection level of an enhanced layer is 3 dB, a combined signal may be expressed by $S_C + \sqrt{\frac{1}{2}} S_E$.

[00188] Since the power of a combined signal (a multiplexed signal) increases compared to a core layer signal, the power normalizer 345 needs to mitigate the increase in power.

[00189] The output of the power normalizer 345 may be expressed by $\beta(S_C + \alpha S_E)$.

[00190] In this case, β is normalizing factors based on various injection levels of the enhanced layer.

5 [00191] When the injection level of the enhanced layer is 3 dB, the power of the combined signal is increased by 50% compared to that of the core layer signal. Accordingly, the output of the power normalizer 345 may be expressed by $\sqrt{\frac{2}{3}}(S_C + \sqrt{\frac{1}{2}}S_E)$.

10 [00192] Table 1 below lists scaling factors α and normalizing factors β for various injection levels (CL: Core Layer, EL: Enhanced Layer). The relationships among the injection level, the scaling factor α and the normalizing factor β may be defined by Equation 3 below:

$$\begin{cases} \alpha = 10^{\left(\frac{-\text{Injection level}}{20}\right)} \\ \beta = \frac{1}{\sqrt{1 + \alpha^2}} \end{cases} \quad (3)$$

Table 1

EL Injection level relative to CL	Scaling factor α	Normalizing factor β
3.0 dB	0.7079458	0.8161736
3.5 dB	0.6683439	0.8314061
4.0 dB	0.6309573	0.8457262
4.5 dB	0.5956621	0.8591327
5.0 dB	0.5623413	0.8716346
5.5 dB	0.5308844	0.8832495
6.0 dB	0.5011872	0.8940022
6.5 dB	0.4731513	0.9039241
7.0 dB	0.4466836	0.9130512
7.5 dB	0.4216965	0.9214231
8.0 dB	0.3981072	0.9290819
8.5 dB	0.3758374	0.9360712
9.0 dB	0.3548134	0.9424353
9.5 dB	0.3349654	0.9482180
10.0 dB	0.3162278	0.9534626

15 [00193] That is, the power normalizer 345 corresponds to the normalizing factor, and reduces the power of the multiplexed signal by a level by which the combiner 340 has increased the power.

[00194] In this case, each of the normalizing factor and the scaling factor may be a rational number that is larger than 0 and smaller than 1.

5 [00195] In this case, the scaling factor may decrease as a reduction in power corresponding to the injection level controller 330 becomes larger, and the normalizing factor may increase as a reduction in power corresponding to the injection level controller 330 becomes larger.

[00196] The power normalized signal passes through the time interleaver 350 for distributing burst errors occurring over a channel.

10 [00197] In this case, the time interleaver 350 may be viewed as performing interleaving that is applied to both the core layer signal and the enhanced layer signal. That is, the core layer and the enhanced layer share the time interleaver, thereby preventing the unnecessary use of memory and also reducing latency at the receiver.

15 [00198] Although will be described later in greater detail, the enhanced layer signal may correspond to enhanced layer data restored based on cancellation corresponding to the restoration of core layer data corresponding to the core layer signal. The combiner 340 may combine one or more extension layer signals having power levels lower than those of the core layer signal and the enhanced layer signal with the core layer signal and the enhanced layer signal.

20 [00199] Meanwhile, L1 signaling information including injection level information is encoded by the signaling generation unit 360 including signaling-dedicated BICM. In this case, the signaling generation unit 360 may receive injection level information IL INFO from the injection level controller 330, and may generate an L1 signaling signal.

25 [00200] In L1 signaling, L1 refers to Layer-1 in the lowest layer of the ISO 7 layer model. In this case, the L1 signaling may be included in a preamble.

30 [00201] In general, the L1 signaling may include an FFT size, a guard interval size, etc., i.e., the important parameters of the OFDM transmitter, a channel code rate, modulation information, etc., i.e., BICM important parameters. This L1 signaling signal is combined with data signal into a broadcast signal frame.

35 [00202] The frame builder 370 generates a broadcast signal frame by combining the L1 signaling signal with a data signal. In this case, the frame builder 370 may generate the broadcast signal frame including a preamble for signaling size information of Physical Layer Pipes (PLPs) and time interleaver information shared by the core layer signal and the enhanced layer signal, using

the time interleaved signal. In this case, the broadcast signal frame may further include a bootstrap.

5 [00203] In this case, the frame builder 370 may generate the broadcast signal frame which includes a preamble for signaling time interleaver information corresponding to the time interleaver 350.

10 [00204] In this case, the time interleaver 350 may use one of time interleaver groups, a boundary between the time interleaver groups may be a boundary between Physical Layer Pipes (PLPs) of a core layer corresponding to the core layer signal. That is, one of boundaries between Physical Layer Pipes (PLPs) of the core layer may be a boundary between the time interleaver groups.

[00205] In this case, the time interleaver information may be signaled on the basis of the core layer.

15 [00206] According to an embodiment, a part of the time interleaver information may be signaled on the basis of the core layer, and the other part of the time interleaver information may be signaled regardless of the layers.

[00207] That is, the time interleaver information may be signaled based on the layer identification information corresponding to the core layer.

20 [00208] In this case, the time interleaver 350 may correspond to a hybrid time interleaver. In this case, the Physical Layer Pipes (PLPs) of a core layer and an enhanced layer may include only complete FEC blocks.

25 [00209] In this case, the preamble may be for signaling information for identifying a part of a FEC block in the enhanced layer in case that the boundary between the time interleaver groups does not correspond to a boundary between FEC blocks in the enhanced layer, the FEC block corresponding to the boundary between the time interleaver groups.

30 [00210] In this case, the information for identifying the part of the FEC block may include at least one of start position information of a Physical Layer Pipe (PLP) in the core layer, start position information of a Physical Layer Pipe (PLP) in the enhanced layer, modulation information corresponding to the enhanced layer, and FEC type information corresponding to the enhanced layer.

[00211] In this case, the start position information of the Physical Layer Pipe (PLP) may correspond to an index of a first data cell of the Physical Layer Pipe (PLP).

35 [00212] In this case, the modulation information may be signaled only if the FEC type information satisfies a predetermined condition.

[00213] In this case, the enhanced layer signal may correspond to enhanced layer data that is restored based on cancellation corresponding to restoration of core layer data corresponding to the core layer signal.

5 **[00214]** In this case, the time interleaver 350 may correspond to a convolutional time interleaver, the time interleaver groups may include the Physical Layer Pipe (PLP) which includes an incomplete FEC block, and the preamble may be for signaling start position information of a first complete FEC block in the Physical Layer Pipe (PLP).

10 **[00215]** In this case, the time interleaver 350 may perform the interleaving by using one of a plurality of operation modes.

[00216] In this case, the operations modes may include a first mode (L1D_plp_TI_mode=00) corresponding to no time interleaving, a second mode (L1D_plp_TI_mode=01) for performing a Convolutional time interleaving and a third mode (L1D_plp_TI_mode=10) for performing a Hybrid time interleaving.

15 **[00217]** In this case, the preamble may include a field indicating a start position of a first complete FEC block corresponding to a current Physical Layer Pipe for the first mode and the second mode, and may not include the field indicating the start position of the first FEC block for the third mode.

20 **[00218]** In this case, the field indicating the start position of the first FEC block may be one of a first field (L1D_plp_fec_block_start) used in the first mode (L1D_plp_TI_mode=00) and a second field (L1D_plp_CTI_fec_block_start) used in the second mode (L1D_plp_TI_mode=01), and the first field and the second field may have different lengths. In this case, the first field (L1D_plp_fec_block_start) may indicate a start position of a first FEC block starting in a current Physical Layer Pipe during a current subframe and the second field (L1D_plp_CTI_fec_block_start) may indicate a start position of a first complete FEC block of a current Physical Layer Pipe leaving a Convolutional time interleaver in current or subsequent subframes. In this case, both the first field (L1D_plp_fec_block_start) and the second field (L1D_plp_CTI_fec_block_start) may be signaled based on after interleaving. In particular, in the case of the second field (L1D_plp_CTI_fec_block_start), the number of bits required for signaling may increase when the signaling is performed based on after interleaving.

35 **[00219]** In this case, the length of the second field may be longer than the length of the first field.

5 [00220] In this case, the length of the first field may be determined based on a length of a LDPC codeword and a modulation order and the length of the second field may be determined not only by the length of the LDPC codeword and the modulation order but also by further considering a depth of a Convolutional time interleaver.

[00221] In this case, the length of the first field may be 15 bits and the length of the second field may be 22 bits.

10 [00222] In this case, the first field and the second field may be separately signaled for each of a core layer corresponding to the core layer signal and an enhanced layer corresponding to the enhanced layer signal.

[00223] In this case, the frame builder 370 may include a bootstrap generator configured to generate the bootstrap, a preamble generator configured to generate the preamble, and a super-imposed payload generator configured to generate a super-imposed payload corresponding to the time-interleaved signal.

15 [00224] In this case, the bootstrap may be shorter than the preamble, and have a fixed-length.

[00225] In this case, the bootstrap may include a symbol representing a structure of the preamble, the symbol corresponding to a fixed-length bit string representing a combination of a modulation scheme/code rate, a FFT size, a guard interval length and a pilot pattern of the preamble.

20

[00226] In this case, the symbol may correspond to a lookup table in which a preamble structure corresponding to a second FFT size is allocated prior to a preamble structure corresponding to a first FFT size, the second FFT size being less than the first FFT size when the modulation scheme/code rates are the same, and a preamble structure corresponding to a second guard interval length is allocated prior to a preamble structure corresponding to a first guard interval length, the second guard interval length being longer than the first guard interval length when the modulation scheme/code rates are the same and the FFT sizes are the same.

25

30 [00227] The broadcast signal frame may be transmitted via the OFDM transmitter that is robust to a multi-path and the Doppler phenomenon. In this case, the OFDM transmitter may be viewed as being responsible for the transmission signal generation of the next generation broadcasting system.

35 [00228] In this case, the preamble may include a PLP identification information for identifying Physical Layer Pipes (PLPs); and a layer identification information for identifying layers corresponding to division of layers.

[00229] In this case, the PLP identification information and the layer identification information may be included in the preamble as fields different from each other.

5 **[00230]** In this case, the time interleaver information may be included in the preamble on the basis of a core layer.

[00231] In this case, the preamble may selectively include an injection level information corresponding to the injection level controller for each of the Physical Layer Pipes (PLPs) based on a result of comparing (IF($j>0$)) the layer identification information with a predetermined value.

10 **[00232]** In this case, the injection level information may be signaled by using 31 values which are identified using a 5 bit-field.

[00233] In this case, the power normalizer may correspond to a normalizing factor which increases as a power reduction corresponding to the injection level controller becomes larger, and the injection level controller may correspond to a scaling factor which decreases as the power reduction corresponding to the injection level controller becomes larger.

15 **[00234]** In this case, the 31 values may be matched with 5 bit field values belonging to any one of a first section corresponding to a first step size and a second section corresponding to a second step size, the second step size being different from the first step size.

[00235] In this case, the first section may correspond to a first rate of change of the scaling factor and the second section may correspond to a second rate of change of the scaling factor, the second rate of change being less than the first rate of change.

20 **[00236]** In this case, the first section may correspond to a section from 0 dB to 5 dB and the second section may correspond to a section from 6 dB to 25 dB.

[00237] In this case, the first step size may be 0.5 dB and the second step size may be 1 dB.

[00238] In this case, the first section may include 5 bit-field values belonging to a section of 0 dB (inclusive) ~ 3 dB (exclusive) and the second section may include 5 bit-field values belonging to a section of 10 dB (exclusive) ~ 25 dB (inclusive).

[00239] In this case, the preamble may include layer identification information for identifying layers corresponding to a hierarchical division.

35 **[00240]** In this case, the preamble may selectively include the injection level information according to a result of comparing the layer identification information with a predetermined value for each of Physical Layer Pipes (PLPs).

[00241] In this case, the preamble may include type information, start position information and size information of the Physical Layer Pipes

[00242] In this case, the type information may be for identifying one among a first type corresponding to a non-dispersed physical layer pipe and a second type corresponding to a dispersed physical layer pipe.

[00243] In this case, the non-dispersed physical layer pipe may be assigned for contiguous data cell indices, and the dispersed physical layer pipe may include two or more subslices.

[00244] In this case, the type information may be selectively signaled according to a result of comparing the layer identification information with a predetermined value for each of the Physical Layer Pipes (PLPs).

[00245] In this case, the type information may be signaled only for the core layer.

[00246] In this case, the start position information may be identical to an index corresponding to the first data cell of the physical layer pipe.

[00247] In this case, the start position information may indicate the start position of the physical layer pipe using cell addressing scheme.

[00248] In this case, the start position information may be included in the preamble for each of the Physical Layer Pipes (PLPs) without checking a condition of a conditional statement corresponding to the layer identification information.

[00249] In this case, the size information may be generated based on the number of data cells assigned to the physical layer pipe.

[00250] In this case, the size information may be included in the preamble for each of the Physical Layer Pipes (PLPs) without checking a condition of a conditional statement corresponding to the layer identification information.

[00251] FIG. 4 is a diagram showing an example of the structure of a broadcast signal frame.

[00252] Referring to FIG. 4, a broadcast signal frame includes the bootstrap 411, the preamble 421 and the super-imposed payload 431.

[00253] The frame shown in FIG. 4, may be included in the super-frame.

[00254] In this case, the broadcast signal frame may include at least one of OFDM symbols. The broadcast signal frame may include a reference symbol or a pilot symbol.

[00255] The frame structure in which the Layered Division Multiplexing (LDM) is applied includes the bootstrap 411, the preamble 421 and the super-imposed payload 431 as shown in FIG. 4.

[00256] In this case, the bootstrap 411 and the preamble 421 may be seen as the two hierarchical preambles.

[00257] In this case, the bootstrap 411 may have a shorter length than the preamble 421 for the fast acquisition and detection. In this case, the bootstrap 411 may have a fixed-length. In this case, the bootstrap may include a fixed-length symbol. For example, the bootstrap 411 may consist of four OFDM symbols each of which has 0.5ms length so that the bootstrap 411 may correspond to the fixed time length of 2ms.

[00258] In this case, the bootstrap 411 may have a fixed bandwidth, and the preamble 421 and the super-imposed payload 431 may have a variable bandwidth wider than the bootstrap 411.

[00259] The preamble 421 may transmit detailed signaling information using a robust LDPC code. In this case, the length of the preamble 421 can be varied according to the signaling information.

[00260] In this case, both the bootstrap 411 and the payload 431 may be seen as a common signal which is shared by a plurality of layers.

[00261] The super-imposed payload 431 may correspond to a multiplexed signal of at least two layer signals. In this case, the super-imposed payload 431 may be generated by combining a core layer payload and an enhanced layer payload at different power levels. In this case, the core layer payload may include an in-band signaling section. In this case, the in-band signaling section may include signaling information for the enhanced layer service.

[00262] In this case, the bootstrap 411 may include a symbol representing a preamble structure.

[00263] In this case, the symbol which included in the bootstrap for representing the preamble structure may be set as shown in the Table 2 below.

Table 2

preamble_structure	L1-Basic Mode	FFT Size	GI Length (samples)	Pilot Pattern (DX)
0	L1-Basic Mode 1	8192	2048	3
1	L1-Basic Mode 1	8192	1536	4
2	L1-Basic Mode 1	8192	1024	3
3	L1-Basic Mode 1	8192	768	4
4	L1-Basic Mode 1	16384	4096	3
5	L1-Basic Mode 1	16384	3648	4
6	L1-Basic Mode 1	16384	2432	3
7	L1-Basic Mode 1	16384	1536	4
8	L1-Basic Mode 1	16384	1024	6

preamble_structure	L1-Basic Mode	FFT Size	GI Length (samples)	Pilot Pattern (DX)
9	L1-Basic Mode 1	16384	768	8
10	L1-Basic Mode 1	32768	4864	3
11	L1-Basic Mode 1	32768	3648	3
12	L1-Basic Mode 1	32768	3648	8
13	L1-Basic Mode 1	32768	2432	6
14	L1-Basic Mode 1	32768	1536	8
15	L1-Basic Mode 1	32768	1024	12
16	L1-Basic Mode 1	32768	768	16
17	L1-Basic Mode 2	8192	2048	3
18	L1-Basic Mode 2	8192	1536	4
19	L1-Basic Mode 2	8192	1024	3
20	L1-Basic Mode 2	8192	768	4
21	L1-Basic Mode 2	16384	4096	3
22	L1-Basic Mode 2	16384	3648	4
23	L1-Basic Mode 2	16384	2432	3
24	L1-Basic Mode 2	16384	1536	4
25	L1-Basic Mode 2	16384	1024	6
26	L1-Basic Mode 2	16384	768	8
27	L1-Basic Mode 2	32768	4864	3
28	L1-Basic Mode 2	32768	3648	3
29	L1-Basic Mode 2	32768	3648	8
30	L1-Basic Mode 2	32768	2432	6
31	L1-Basic Mode 2	32768	1536	8
32	L1-Basic Mode 2	32768	1024	12
33	L1-Basic Mode 2	32768	768	16
34	L1-Basic Mode 3	8192	2048	3
35	L1-Basic Mode 3	8192	1536	4
36	L1-Basic Mode 3	8192	1024	3
37	L1-Basic Mode 3	8192	768	4
38	L1-Basic Mode 3	16384	4096	3
39	L1-Basic Mode 3	16384	3648	4
40	L1-Basic Mode 3	16384	2432	3
41	L1-Basic Mode 3	16384	1536	4
42	L1-Basic Mode 3	16384	1024	6
43	L1-Basic Mode 3	16384	768	8
44	L1-Basic Mode 3	32768	4864	3
45	L1-Basic Mode 3	32768	3648	3
46	L1-Basic Mode 3	32768	3648	8
47	L1-Basic Mode 3	32768	2432	6
48	L1-Basic Mode 3	32768	1536	8

preamble_structure	L1-Basic Mode	FFT Size	GI Length (samples)	Pilot Pattern (DX)
49	L1-Basic Mode 3	32768	1024	12
50	L1-Basic Mode 3	32768	768	16
51	L1-Basic Mode 4	8192	2048	3
52	L1-Basic Mode 4	8192	1536	4
53	L1-Basic Mode 4	8192	1024	3
54	L1-Basic Mode 4	8192	768	4
55	L1-Basic Mode 4	16384	4096	3
56	L1-Basic Mode 4	16384	3648	4
57	L1-Basic Mode 4	16384	2432	3
58	L1-Basic Mode 4	16384	1536	4
59	L1-Basic Mode 4	16384	1024	6
60	L1-Basic Mode 4	16384	768	8
61	L1-Basic Mode 4	32768	4864	3
62	L1-Basic Mode 4	32768	3648	3
63	L1-Basic Mode 4	32768	3648	8
64	L1-Basic Mode 4	32768	2432	6
65	L1-Basic Mode 4	32768	1536	8
66	L1-Basic Mode 4	32768	1024	12
67	L1-Basic Mode 4	32768	768	16
68	L1-Basic Mode 5	8192	2048	3
69	L1-Basic Mode 5	8192	1536	4
70	L1-Basic Mode 5	8192	1024	3
71	L1-Basic Mode 5	8192	768	4
72	L1-Basic Mode 5	16384	4096	3
73	L1-Basic Mode 5	16384	3648	4
74	L1-Basic Mode 5	16384	2432	3
75	L1-Basic Mode 5	16384	1536	4
76	L1-Basic Mode 5	16384	1024	6
77	L1-Basic Mode 5	16384	768	8
78	L1-Basic Mode 5	32768	4864	3
79	L1-Basic Mode 5	32768	3648	3
80	L1-Basic Mode 5	32768	3648	8
81	L1-Basic Mode 5	32768	2432	6
82	L1-Basic Mode 5	32768	1536	8
83	L1-Basic Mode 5	32768	1024	12
84	L1-Basic Mode 5	32768	768	16
85	L1-Basic Mode 6	8192	2048	3
86	L1-Basic Mode 6	8192	1536	4
87	L1-Basic Mode 6	8192	1024	3
88	L1-Basic Mode 6	8192	768	4

preamble_structure	L1-Basic Mode	FFT Size	GI Length (samples)	Pilot Pattern (DX)
89	L1-Basic Mode 6	16384	4096	3
90	L1-Basic Mode 6	16384	3648	4
91	L1-Basic Mode 6	16384	2432	3
92	L1-Basic Mode 6	16384	1536	4
93	L1-Basic Mode 6	16384	1024	6
94	L1-Basic Mode 6	16384	768	8
95	L1-Basic Mode 6	32768	4864	3
96	L1-Basic Mode 6	32768	3648	3
97	L1-Basic Mode 6	32768	3648	8
98	L1-Basic Mode 6	32768	2432	6
99	L1-Basic Mode 6	32768	1536	8
100	L1-Basic Mode 6	32768	1024	12
101	L1-Basic Mode 6	32768	768	16
102	L1-Basic Mode 7	8192	2048	3
103	L1-Basic Mode 7	8192	1536	4
104	L1-Basic Mode 7	8192	1024	3
105	L1-Basic Mode 7	8192	768	4
106	L1-Basic Mode 7	16384	4096	3
107	L1-Basic Mode 7	16384	3648	4
108	L1-Basic Mode 7	16384	2432	3
109	L1-Basic Mode 7	16384	1536	4
110	L1-Basic Mode 7	16384	1024	6
111	L1-Basic Mode 7	16384	768	8
112	L1-Basic Mode 7	32768	4864	3
113	L1-Basic Mode 7	32768	3648	3
114	L1-Basic Mode 7	32768	3648	8
115	L1-Basic Mode 7	32768	2432	6
116	L1-Basic Mode 7	32768	1536	8
117	L1-Basic Mode 7	32768	1024	12
118	L1-Basic Mode 7	32768	768	16
119	Reserved	Reserved	Reserved	Reserved
120	Reserved	Reserved	Reserved	Reserved
121	Reserved	Reserved	Reserved	Reserved
122	Reserved	Reserved	Reserved	Reserved
123	Reserved	Reserved	Reserved	Reserved
124	Reserved	Reserved	Reserved	Reserved
125	Reserved	Reserved	Reserved	Reserved
126	Reserved	Reserved	Reserved	Reserved
127	Reserved	Reserved	Reserved	Reserved

- [00264] For example, a fixed-length symbol of 7-bit may be assigned for representing the preamble structure shown in the Table 2.
- [00265] The L1-Basic Mode 1, L1-Basic Mode 2 and L1-Basic Mode 3 in the Table 2 may correspond to QPSK and 3/15 LDPC.
- 5 [00266] The L1 Basic Mode 4 in the Table 2 may correspond to 16-NUC (Non Uniform Constellation) and 3/15 LDPC.
- [00267] The L1 Basic Mode 5 in the Table 2 may correspond to 64-NUC (Non Uniform Constellation) and 3/15 LDPC.
- 10 [00268] The L1-Basic Mode 6 and L1-Basic Mode 7 in the Table 2 may correspond to 256-NUC (Non Uniform Constellation) and 3/15 LDPC. Hereafter, the modulation scheme/code rate represents a combination of a modulation scheme and a code rate such as QPSK and 3/15 LDPC.
- [00269] The FFT size in the Table 2 may represent a size of Fast Fourier Transform.
- 15 [00270] The GI length in the Table 2 may represent the Guard Interval Length, may represent a length of the guard interval which is not data in a time domain. In this case, the guard interval is longer, the system is more robust.
- [00271] The Pilot Pattern in the Table 2 may represent D_x of the pilot pattern. Although it is not shown in the Table 2 explicitly, D_y may be all 1 in the example of Table 2. For example, $D_x = 3$ may mean that one pilot for channel estimation is included in x-axis direction in every three symbols. For example, $D_y = 1$ may mean the pilot is included every time in y-axis direction.
- 20 [00272] As shown in the Table 2, the preamble structure corresponding to a second modulation scheme/code rate which is more robust than a first modulation scheme/code rate may be allocated in the lookup table prior to the preamble structure corresponding to the first modulation scheme/code rate.
- [00273] In this case, the being allocated prior to other preamble structure may mean being stored in the lookup table corresponding to a serial number less than the serial number of the other preamble structure.
- 30 [00274] Furthermore, the preamble structure corresponding to a second FFT size which is shorter than a first FFT size may be allocated in the lookup table prior to the preamble structure corresponding to a first FFT size in case of the same modulation scheme/code rate.
- [00275] Furthermore, the preamble structure corresponding to a second guard interval which is longer than a first guard interval may be allocated in the lookup table prior to the preamble structure corresponding to the first guard interval in case of the same modulation scheme/code rate and the same FFT size.
- 35

[00276] As shown in the Table 2, the setting of the order in which the preamble structures are assigned in the lookup table may make the recognition of the preamble structure using the bootstrap more efficient.

5 [00277] FIG. 5 is a diagram showing an example of the receiving process of the broadcast signal frame shown in FIG. 4.

[00278] Referring to Fig. 5, the bootstrap 511 is detected and demodulated, and the signaling information is reconstructed by the demodulation of the preamble 521 using the demodulated information.

10 [00279] The core layer data 531 is demodulated using the signaling information and the enhanced layer payload 541 of the enhanced layer signal is demodulated through the cancellation process corresponding to the core layer data. In this case, the cancellation corresponding to the core layer data will be described in detail later.

15 [00280] FIG. 6 is a diagram showing another example of the receiving process of the broadcast signal frame shown in FIG. 4.

[00281] Referring to FIG. 6, the bootstrap 610 is detected and demodulated, and the signaling information is reconstructed by the demodulation of the preamble 620 using the demodulated information.

20 [00282] The core layer data 630 is demodulated using the signaling information. In this case, the core layer data 630 includes in-band signaling section 650. The in-band signaling section 650 includes signaling information for the enhanced layer payload 640 of the enhanced layer service. The bandwidth is used more efficiently through the in-band signaling section 650. In this case, the in-band signaling section 651 may be included in the core layer
25 which is more robust than the enhanced layer.

[00283] The basic signaling information and the information for the core layer service may be transferred through the preamble 620 and the signaling information for the enhanced layer service may be transferred through the in-band signaling section 650 in the example of the FIG. 6.

30 [00284] The enhanced layer signal is demodulated through the cancellation process corresponding to the core layer data.

[00285] In this case, the signaling information may be L1 (Layer-1) signaling information. The L1 signaling information may include information for physical layer parameters.

35 [00286] Referring to FIG. 4, a broadcast signal frame includes an L1 signaling signal and a data signal. For example, the broadcast signal frame may be an ATSC 3.0 frame.

[00288] Referring to FIG. 7, it can be seen that an apparatus for generating broadcast signal frame multiplexes data corresponding to N (N is a natural number that is equal to or larger than 1) extension layers together in addition to core layer data and enhanced layer data.

5 **[00289]** That is, the apparatus for generating the broadcast signal frame in FIG. 7 includes N extension layer BICM units 410,..., 430 and injection level controllers 440,..., 460 in addition to a core layer BICM unit 310, an enhanced layer BICM unit 320, an injection level controller 330, a combiner 340, a power normalizer 345, a time interleaver 350, a signaling generation unit 360, and a
10 frame builder 370.

[00290] The core layer BICM unit 310, enhanced layer BICM unit 320, injection level controller 330, combiner 340, power normalizer 345, time interleaver 350, signaling generation unit 360 and frame builder 370 shown in FIG. 7 have been described in detail with reference to FIG. 3.

15 **[00291]** Each of the N extension layer BICM units 410,..., 430 independently performs BICM encoding, and each of the injection level controllers 440,..., 460 performs power reduction corresponding to a corresponding extension layer, thereby enabling a power reduced extension layer signal to be combined with other layer signals via the combiner 340.

20 **[00292]** In this case, each of the error correction encoders of the extension layer BICM units 410,..., 430 may be formed by connecting a BCH encoder and an LDPC encoder in series.

[00293] In particular, it is preferred that a reduction in power corresponding to each of the injection level controllers 440,..., 460 be higher than the reduction
25 in power of the injection level controller 330. That is, a lower one of the injection level controllers 330, 440,..., 460 shown in FIG. 7 may correspond to a larger reduction in power.

[00294] Injection level information provided by the injection level controllers 330, 440 and 460 shown in FIG. 7 is included in the broadcast signal
30 frame of the frame builder 370 via the signaling generation unit 360, and is then transmitted to the receiver. That is, the injection level of each layer is contained in the L1 signaling information and then transferred to the receiver.

[00295] In the present invention, the adjustment of power may correspond to increasing or decreasing the power of an input signal, and may correspond to
35 increasing or decreasing the gain of an input signal.

[00296] The power normalizer 345 mitigates an increase in power caused by the combination of a plurality of layer signals by means of the combiner 340.

[00297] In the example shown in FIG. 7, the power normalizer 345 may adjust the power of a signal to appropriate magnitude by multiplying the magnitude of a signal, into which the signals of the respective layers are combined, by a normalizing factor by using Equation 4 below:

$$\text{Normalizing factor} = \left(\sqrt{1 + 10^{-\text{Injectionlevel}\#1(\text{dB})/10} + 10^{-\text{Injectionlevel}\#2(\text{dB})/10} + \Lambda + 10^{-\text{Injectionlevel}\#(N+1)(\text{dB})/10}} \right)^{-1} \quad (4)$$

[00298] The time interleaver 350 performs interleaving equally applied to the signals of the layers by interleaving the signals combined by the combiner 340.

[00299] FIG. 8 is a block diagram showing still an example of the signal demultiplexer shown in FIG. 1.

[00300] Referring to FIG. 8, a signal demultiplexer according to an embodiment of the present invention includes a time deinterleaver 510, a de-normalizer 1010, core layer BICM decoder 520, an enhanced layer symbol extractor 530, a de-injection level controller 1020, and an enhanced layer BICM decoder 540.

[00301] In this case, the signal demultiplexer shown in FIG. 8 may correspond to the apparatus for generating the broadcast signal frame shown in FIG. 3.

[00302] The time deinterleaver 510 receives a received signal from an OFDM receiver for performing operations, such as time/frequency synchronization, channel estimation and equalization, and performs an operation related to the distribution of burst errors occurring over a channel. In this case, the L1 signaling information is decoded by the OFDM receiver first, and is then used for the decoding of data. In particular, the injection level information of the L1 signaling information may be transferred to the de-normalizer 1010 and the de-injection level controller 1020. In this case, the OFDM receiver may decode the received signal in the form of a broadcast signal frame, for example, an ATSC 3.0 frame, may extract the data symbol part of the frame, and may provide the extracted data symbol part to the time deinterleaver 510. That is, the time deinterleaver 510 distributes burst errors occurring over a channel by performing deinterleaving while passing a data symbol therethrough.

[00303] In this case, the time deinterleaver 510 may perform an operation corresponding to the time interleaver. In this case, the time deinterleaver 510 may perform the deinterleaving by using one of a plurality of operation modes

and may perform the deinterleaving by using the time interleaver information signaled related to the operation of the time interleaver.

5 [00304] The de-normalizer 1010 corresponds to the power normalizer of the transmitter, and increases power by a level by which the power normalizer has decreased the power. That is, the de-normalizer 1010 divides the received signal by the normalizing factor of Equation 2.

10 [00305] Although the de-normalizer 1010 is illustrated as adjusting the power of the output signal of the time interleaver 510 in the example shown in FIG. 8, the de-normalizer 1010 may be located before the time interleaver 510 so that power adjustment is performed before interleaving in some embodiments.

[00306] That is, the de-normalizer 1010 may be viewed as being located before or after the time interleaver 510 and amplifying the magnitude of a signal for the purpose of the LLR calculation of the core layer symbol demapper.

15 [00307] The output of the time deinterleaver 510 (or the output of the de-normalizer 1010) is provided to the core layer BICM decoder 520, and the core layer BICM decoder 520 restores core layer data.

[00308] In this case, the core layer BICM decoder 520 includes a core layer symbol demapper, a core layer bit deinterleaver, and a core layer error correction decoder. The core layer symbol demapper calculates LLR values related to symbols, the core layer bit deinterleaver strongly mixes the calculated LLR values with burst errors, and the core layer error correction decoder corrects error occurring over a channel.

20 [00309] In this case, the core layer symbol demapper may calculate an LLR value for each bit using a predetermined constellation. In this case, the constellation used by the core layer symbol mapper may vary depending on the combination of the code rate and the modulation order that are used by the transmitter.

[00310] In this case, the core layer bit deinterleaver may perform deinterleaving on calculated LLR values on an LDPC code word basis.

30 [00311] In particular, the core layer error correction decoder may output only information bits, or may output all bits in which information bits have been mixed with parity bits. In this case, the core layer error correction decoder may output only information bits as core layer data, and may output all bits in which information bits have been mixed with parity bits to the enhanced layer symbol extractor 530.

35 [00312] The core layer error correction decoder may be formed by connecting a core layer LDPC decoder and a core layer BCH decoder in series.

That is, the input of the core layer error correction decoder may be input to the core layer LDPC decoder, the output of the core layer LDPC decoder may be input to the core layer BCH decoder, and the output of the core layer BCH decoder may become the output of the core layer error correction decoder. In this case, the LDPC decoder performs LDPC decoding, and the BCH decoder performs BCH decoding.

[00313] Furthermore, the enhanced layer error correction decoder may be formed by connecting an enhanced layer LDPC decoder and an enhanced layer BCH decoder in series. That is, the input of the enhanced layer error correction decoder may be input to the enhanced layer LDPC decoder, the output of the enhanced layer LDPC decoder may be input to the enhanced layer BCH decoder, and the output of the enhanced layer BCH decoder may become the output of the enhanced layer error correction decoder.

[00314] The enhanced layer symbol extractor 530 may receive all bits from the core layer error correction decoder of the core layer BICM decoder 520, may extract enhanced layer symbols from the output signal of the time deinterleaver 510 or de-normalizer 1010. In an embodiment, the enhanced layer symbol extractor 530 may not be provided with all bits by the error correction decoder of the core layer BICM decoder 520, but may be provided with LDPC information bits or BCH information bits by the error correction decoder of the core layer BICM decoder 520.

[00315] In this case, the enhanced layer symbol extractor 530 includes a buffer, a subtracter, a core layer symbol mapper, and a core layer bit interleaver. The buffer stores the output signal of the time deinterleaver 510 or de-normalizer 1010. The core layer bit interleaver receives the all bits (information bits + parity bits) of the core layer BICM decoder, and performs the same core layer bit interleaving as the transmitter. The core layer symbol mapper generates core layer symbols, which are the same as the transmitter, from the interleaved signal. The subtracter obtains enhanced layer symbols by subtracting the output signal of the core layer symbol mapper from the signal stored in the buffer, and transfers the enhanced layer symbols to the de-injection level controller 1020. In particular, when LDPC information bits are provided, the enhanced layer symbol extractor 530 may further include a core layer LDPC encoder. Furthermore, when BCH information bits are provided, the enhanced layer symbol extractor 530 may further include not only a core layer LDPC encoder but also a core layer BCH encoder.

5 [00316] In this case, the core layer LDPC encoder, core layer BCH encoder, core layer bit interleaver and core layer symbol mapper included in the enhanced layer symbol extractor 530 may be the same as the LDPC encoder, BCH encoder, bit interleaver and symbol mapper of the core layer described with reference to FIG. 3.

10 [00317] The de-injection level controller 1020 receives the enhanced layer symbols, and increases the power of the input signal by a level by which the injection level controller of the transmitter has decreased the power. That is, the de-injection level controller 1020 amplifies the input signal, and provides the amplified input signal to the enhanced layer BICM decoder 540. For example, if at the transmitter, the power used to combine the enhanced layer signal is lower than the power used to combine the core layer signal by 3 dB, the de-injection level controller 1020 functions to increase the power of the input signal by 3 dB.

15 [00318] In this case, the de-injection level controller 1020 may be viewed as receiving injection level information from the OFDM receiver and multiplying an extracted enhanced layer signal by the enhanced layer gain of Equation 5:

$$\text{Enhanced layer gain} = \left(\sqrt{10^{-\text{Injection level (dB)/10}}} \right)^{-1} \quad (5)$$

20 [00319] The enhanced layer BICM decoder 540 receives the enhanced layer symbol whose power has been increased by the de-injection level controller 1020, and restores the enhanced layer data.

25 [00320] In this case, the enhanced layer BICM decoder 540 may include an enhanced layer symbol demapper, an enhanced layer bit deinterleaver, and an enhanced layer error correction decoder. The enhanced layer symbol demapper calculates LLR values related to the enhanced layer symbols, the enhanced layer bit deinterleaver strongly mixes the calculated LLR values with burst errors, and the enhanced layer error correction decoder corrects error occurring over a channel.

30 [00321] Although the enhanced layer BICM decoder 540 performs a task similar to a task that is performed by the core layer BICM decoder 520, the enhanced layer LDPC decoder generally performs LDPC decoding related to a code rate equal to or higher than 6/15.

35 [00322] For example, the core layer may use LDPC code having a code rate equal to or higher than 5/15, and the enhanced layer may use LDPC code having a code rate equal to or higher than 6/15. In this case, in a reception environment in which enhanced layer data can be decoded, core layer data may be decoded using only a small number of LDPC decoding iterations. Using this

characteristic, in the hardware of the receiver, a single LDPC decoder is shared by the core layer and the enhanced layer, and thus the cost required to implement the hardware can be reduced. In this case, the core layer LDPC decoder may use only some time resources (LDPC decoding iterations), and the enhanced layer LDPC decoder may use most time resources.

[00323] That is, the signal demultiplexer shown in FIG. 8 restores core layer data first, leaves only the enhanced layer symbols by cancellation the core layer symbols in the received signal symbols, and then restores enhanced layer data by increasing the power of the enhanced layer symbols. As described with reference to FIGS. 3 and 5, signals corresponding to respective layers are combined at different power levels, and thus data restoration having the smallest error can be achieved only if restoration starts with a signal combined with the strongest power.

[00324] Accordingly, in the example shown in FIG. 8, the signal demultiplexer may include the time deinterleaver 510 configured to generate a time-deinterleaved signal by applying time deinterleaving to a received signal; a de-normalizer 1010 configured to increase the power of the received signal or the time-deinterleaved signal by a level corresponding to a reduction in power by the power normalizer of the transmitter; the core layer BICM decoder 520 configured to restore core layer data from the signal power-adjusted by the de-normalizer 1010; the enhanced layer symbol extractor 530 configured to extract an enhanced layer signal by performing cancellation, corresponding to the core layer data, on the signal power-adjusted by the de-normalizer 1010 using the output signal of the core layer FEC decoder of the core layer BICM decoder 520; a de-injection level controller 1020 configured to increase the power of the enhanced layer signal by a level corresponding to a reduction in power by the injection power level controller of the transmitter; and an enhanced layer BICM decoder 540 configured to restore enhanced layer data using the output signal of the de-injection level controller 1020.

[00325] In this case, the enhanced layer symbol extractor may receive all code words from the core layer LDPC decoder of the core layer BICM decoder, and may immediately perform bit interleaving on the all code words.

[00326] In this case, the enhanced layer symbol extractor may receive information bits from the core layer LDPC decoder of the core layer BICM decoder, and may perform core layer LDPC encoding and then bit interleaving on the information bits.

[00327] In this case, the enhanced layer symbol extractor may receive information bits from the core layer BCH decoder of the core layer BICM decoder, and may perform core layer BCH encoding and core layer LDPC encoding and then bit interleaving on the information bits.

5 [00328] In this case, the de-normalizer and the de-injection level controller may receive injection level information IL INFO provided based on L1 signaling, and may perform power control based on the injection level information.

[00329] In this case, the core layer BICM decoder may have a bit rate lower than that of the enhanced layer BICM decoder, and may be more robust than the
10 enhanced layer BICM decoder.

[00330] In this case, the de-normalizer may correspond to the reciprocal of the normalizing factor.

[00331] In this case, the de-injection level controller may correspond to the reciprocal of the scaling factor.

15 [00332] In this case, the enhanced layer data may be restored based on cancellation corresponding to the restoration of core layer data corresponding to the core layer signal.

[00333] In this case, the signal demultiplexer further may include one or more extension layer symbol extractors each configured to extract an extension
20 layer signal by performing cancellation corresponding to previous layer data; one or more de-injection level controllers each configured to increase the power of the extension layer signal by a level corresponding to a reduction in power by the injection level controller of the transmitter; and one or more extension layer BICM decoders configured to restore one or more pieces of extension layer data
25 using the output signals of the one or more de-injection level controllers.

[00334] From the configuration shown in FIG. 8, it can be seen that a signal demultiplexing method according to an embodiment of the present invention includes generating a time-deinterleaved signal by applying time deinterleaving to a received signal; increasing the power of the received signal or the time-deinterleaved signal by a level corresponding to a reduction in power by the
30 power normalizer of the transmitter; restoring core layer data from the power-adjusted signal; extracting an enhanced layer signal by performing cancellation, corresponding to the core layer data, on the power-adjusted signal; increasing the power of the enhanced layer signal by a level corresponding to a reduction in
35 power by the injection power level controller of the transmitter; and restoring enhanced layer data using the enhanced layer data.

[00335] In this case, extracting the enhanced layer signal may include receiving all code words from the core layer LDPC decoder of the core layer BICM decoder, and immediately performing bit interleaving on the all code words.

5 [00336] In this case, extracting the enhanced layer signal may include receiving information bits from the core layer LDPC decoder of the core layer BICM decoder, and performing core layer LDPC encoding and then bit interleaving on the information bits.

10 [00337] In this case, extracting the enhanced layer signal may include receiving information bits from the core layer BCH decoder of the core layer BICM decoder, and performing core layer BCH encoding and core layer LDPC encoding and then bit interleaving on the information bits.

15 [00338] FIG. 9 is a block diagram showing an example of the core layer BICM decoder 520 and the enhanced layer symbol extractor 530 shown in FIG. 8.

[00339] Referring to FIG. 9, the core layer BICM decoder 520 includes a core layer symbol demapper, a core layer bit deinterleaver, a core layer LDPC decoder, and a core layer BCH decoder.

20 [00340] That is, in the example shown in FIG. 9, the core layer error correction decoder includes the core layer LDPC decoder and the core layer BCH decoder.

[00341] Furthermore, in the example shown in FIG. 9, the core layer LDPC decoder provides all code words, including parity bits, to the enhanced layer symbol extractor 530. That is, although the LDPC decoder generally outputs only the information bits of all the LDPC code words, the LDPC decoder may output all the code words.

25 [00342] In this case, although the enhanced layer symbol extractor 530 may be easily implemented because it does not need to include a core layer LDPC encoder or a core layer BCH encoder, there is a possibility that a residual error may remain in the LDPC code parity part.

30 [00343] FIG. 10 is a block diagram showing another example of the core layer BICM decoder 520 and the enhanced layer symbol extractor 530 shown in FIG. 8.

35 [00344] Referring to FIG. 10, the core layer BICM decoder 520 includes a core layer symbol demapper, a core layer bit deinterleaver, a core layer LDPC decoder, and a core layer BCH decoder.

[00345] That is, in the example shown in FIG. 10, the core layer error correction decoder includes the core layer LDPC decoder and the core layer BCH decoder.

5 [00346] Furthermore, in the example shown in FIG. 10, the core layer LDPC decoder provides information bits, excluding parity bits, to the enhanced layer symbol extractor 530.

[00347] In this case, although the enhanced layer symbol extractor 530 does not need to include a core layer BCH encoder, it must include a core layer LDPC encoder.

10 [00348] A residual error that may remain in the LDPC code parity part may be eliminated more desirably in the example shown in FIG. 10 than in the example shown in FIG. 9.

15 [00349] FIG. 11 is a block diagram showing still another example of the core layer BICM decoder 520 and the enhanced layer symbol extractor 530 shown in FIG. 8.

[00350] Referring to FIG. 11, the core layer BICM decoder 520 includes a core layer symbol demapper, a core layer bit deinterleaver, a core layer LDPC decoder, and a core layer BCH decoder.

20 [00351] That is, in the example shown in FIG. 11, the core layer error correction decoder includes the core layer LDPC decoder and the core layer BCH decoder.

[00352] In the example shown in FIG. 11, the output of the core layer BCH decoder corresponding to core layer data is provided to the enhanced layer symbol extractor 530.

25 [00353] In this case, although the enhanced layer symbol extractor 530 has high complexity because it must include both a core layer LDPC encoder and a core layer BCH encoder, it guarantees higher performance than those in the examples of FIGS. 9 and 10.

30 [00354] FIG. 12 is a block diagram showing another example of the signal demultiplexer shown in FIG. 1.

35 [00355] Referring to FIG. 12, a signal demultiplexer according to an embodiment of the present invention includes a time deinterleaver 510, a de-normalizer 1010, a core layer BICM decoder 520, an enhanced layer symbol extractor 530, an enhanced layer BICM decoder 540, one or more extension layer symbol extractors 650 and 670, one or more extension layer BICM decoders 660 and 680, and de-injection level controllers 1020, 1150 and 1170.

[00356] In this case, the signal demultiplexer shown in FIG. 12 may correspond to the apparatus for generating broadcast signal frame shown in FIG. 7.

5 [00357] The time deinterleaver 510 receives a received signal from an OFDM receiver for performing operations, such as synchronization, channel estimation and equalization, and performs an operation related to the distribution of burst errors occurring over a channel. In this case, L1 signaling information may be decoded by the OFDM receiver first, and then may be used for data decoding. In particular, the injection level information of the L1 signaling information may be transferred to the de-normalizer 1010 and the de-injection level controllers 1020, 1150 and 1170.

[00358] In this case, the de-normalizer 1010 may obtain the injection level information of all layers, may obtain a de-normalizing factor using Equation 6 below, and may multiply the input signal with the de-normalizing factor:

$$15 \quad \text{De-normalizing factor} = (\text{normalizing factor})^{-1} = \frac{1}{\left(\sqrt{1 + 10^{-\text{InjectionLevel}\#1(\text{dB})/10} + 10^{-\text{InjectionLevel}\#2(\text{dB})/10} + \Lambda + 10^{-\text{InjectionLevel}\#(N+1)(\text{dB})/10}} \right)} \quad (6)$$

[00359] That is, the de-normalizing factor is the reciprocal of the normalizing factor expressed by Equation 4 above.

20 [00360] In an embodiment, when the N1 signaling includes not only injection level information but also normalizing factor information, the de-normalizer 1010 may simply obtain a de-normalizing factor by taking the reciprocal of a normalizing factor without the need to calculate the de-normalizing factor using an injection level.

25 [00361] The de-normalizer 1010 corresponds to the power normalizer of the transmitter, and increases power by a level by which the power normalizer has decreased the power.

[00362] Although the de-normalizer 1010 is illustrated as adjusting the power of the output signal of the time interleaver 510 in the example shown in FIG. 12, the de-normalizer 1010 may be located before the time interleaver 510 so that power adjustment can be performed before interleaving in an embodiment.

30 [00363] That is, the de-normalizer 1010 may be viewed as being located before or after the time interleaver 510 and amplifying the magnitude of a signal for the purpose of the LLR calculation of the core layer symbol demapper.

[00364] The output of the time deinterleaver 510 (or the output of the de-normalizer 1010) is provided to the core layer BICM decoder 520, and the core layer BICM decoder 520 restores core layer data.

5 [00365] In this case, the core layer BICM decoder 520 includes a core layer symbol demapper, a core layer bit deinterleaver, and a core layer error correction decoder. The core layer symbol demapper calculates LLR values related to symbols, the core layer bit deinterleaver strongly mixes the calculated LLR values with burst errors, and the core layer error correction decoder corrects error occurring over a channel.

10 [00366] In particular, the core layer error correction decoder may output only information bits, or may output all bits in which information bits have been combined with parity bits. In this case, the core layer error correction decoder may output only information bits as core layer data, and may output all bits in which information bits have been combined with parity bits to the enhanced layer symbol extractor 530.

15 [00367] The core layer error correction decoder may be formed by connecting a core layer LDPC decoder and a core layer BCH decoder in series. That is, the input of the core layer error correction decoder may be input to the core layer LDPC decoder, the output of the core layer LDPC decoder may be input to the core layer BCH decoder, and the output of the core layer BCH decoder may become the output of the core layer error correction decoder. In this case, the LDPC decoder performs LDPC decoding, and the BCH decoder performs BCH decoding.

20 [00368] The enhanced layer error correction decoder may be also formed by connecting an enhanced layer LDPC decoder and an enhanced layer BCH decoder in series. That is, the input of the enhanced layer error correction decoder may be input to the enhanced layer LDPC decoder, the output of the enhanced layer LDPC decoder may be input to the enhanced layer BCH decoder, and the output of the enhanced layer BCH decoder may become the output of the enhanced layer error correction decoder.

25 [00369] Moreover, the extension layer error correction decoder may be also formed by connecting an extension layer LDPC decoder and an extension layer BCH decoder in series. That is, the input of the extension layer error correction decoder may be input to the extension layer LDPC decoder, the output of the extension layer LDPC decoder may be input to the extension layer BCH decoder, and the output of the extension layer BCH decoder may become the output of the extension layer error correction decoder.

30 [00369] Moreover, the extension layer error correction decoder may be also formed by connecting an extension layer LDPC decoder and an extension layer BCH decoder in series. That is, the input of the extension layer error correction decoder may be input to the extension layer LDPC decoder, the output of the extension layer LDPC decoder may be input to the extension layer BCH decoder, and the output of the extension layer BCH decoder may become the output of the extension layer error correction decoder.

[00370] In particular, the tradeoff between the complexity of implementation, regarding which of the outputs of the error correction decoders will be used, which has been described with reference to FIGS. 9, 10 and 11, and performance is applied to not only the core layer BICM decoder 520 and enhanced layer symbol extractor 530 of FIG. 12 but also the extension layer symbol extractors 650 and 670 and the extension layer BICM decoders 660 and 680.

[00371] The enhanced layer symbol extractor 530 may receive the all bits from the core layer BICM decoder 520 of the core layer error correction decoder, and may extract enhanced layer symbols from the output signal of the time deinterleaver 510 or the denormalizer 1010. In an embodiment, the enhanced layer symbol extractor 530 may not receive all bits from the error correction decoder of the core layer BICM decoder 520, but may receive LDPC information bits or BCH information bits.

[00372] In this case, the enhanced layer symbol extractor 530 includes a buffer, a subtracter, a core layer symbol mapper, and a core layer bit interleaver. The buffer stores the output signal of the time deinterleaver 510 or de-normalizer 1010. The core layer bit interleaver receives the all bits (information bits + parity bits) of the core layer BICM decoder, and performs the same core layer bit interleaving as the transmitter. The core layer symbol mapper generates core layer symbols, which are the same as the transmitter, from the interleaved signal. The subtracter obtains enhanced layer symbols by subtracting the output signal of the core layer symbol mapper from the signal stored in the buffer, and transfers the enhanced layer symbols to the de-injection level controller 1020.

[00373] In this case, the core layer bit interleaver and core layer symbol mapper included in the enhanced layer symbol extractor 530 may be the same as the core layer bit interleaver and the core layer symbol mapper shown in FIG. 7.

[00374] The de-injection level controller 1020 receives the enhanced layer symbols, and increases the power of the input signal by a level by which the injection level controller of the transmitter has decreased the power. That is, the de-injection level controller 1020 amplifies the input signal, and provides the amplified input signal to the enhanced layer BICM decoder 540.

[00375] The enhanced layer BICM decoder 540 receives the enhanced layer symbol whose power has been increased by the de-injection level controller 1020, and restores the enhanced layer data.

[00376] In this case, the enhanced layer BICM decoder 540 may include an enhanced layer symbol demapper, an enhanced layer bit deinterleaver, and an

enhanced layer error correction decoder. The enhanced layer symbol demapper calculates LLR values related to the enhanced layer symbols, the enhanced layer bit deinterleaver strongly mixes the calculated LLR values with burst errors, and the enhanced layer error correction decoder corrects error occurring over a channel.

5
[00377] In particular, the enhanced layer error correction decoder may output only information bits, and may output all bits in which information bits have been combined with parity bits. In this case, the enhanced layer error correction decoder may output only information bits as enhanced layer data, and may output
10 all bits in which information bits have been mixed with parity bits to the extension layer symbol extractor 650.

[00378] The extension layer symbol extractor 650 receives all bits from the enhanced layer error correction decoder of the enhanced layer BICM decoder 540, and extracts extension layer symbols from the output signal of the de-injection level controller 1020.

15
[00379] In this case, the de-injection level controller 1020 may amplify the power of the output signal of the subtracter of the enhanced layer symbol extractor 530.

[00380] In this case, the extension layer symbol extractor 650 includes a
20 buffer, a subtracter, an enhanced layer symbol mapper, and an enhanced layer bit interleaver. The buffer stores the output signal of the de-injection level controller 1020. The enhanced layer bit interleaver receives the all bits information (bits + parity bits) of the enhanced layer BICM decoder, and performs enhanced layer bit interleaving that is the same as that of the transmitter.
25 The enhanced layer symbol mapper generates enhanced layer symbols, which are the same as those of the transmitter, from the interleaved signal. The subtracter obtains extension layer symbols by subtracting the output signal of the enhanced layer symbol mapper from the signal stored in the buffer, and transfers the extension layer symbols to the extension layer BICM decoder 660.

30
[00381] In this case, the enhanced layer bit interleaver and the enhanced layer symbol mapper included in the extension layer symbol extractor 650 may be the same as the enhanced layer bit interleaver and the enhanced layer symbol mapper shown in FIG. 7.

[00382] The de-injection level controller 1150 increases power by a level by
35 which the injection level controller of a corresponding layer has decreased the power at the transmitter.

[00383] In this case, the de-injection level controller may be viewed as performing the operation of multiplying the extension layer gain of Equation 7 below. In this case, a 0-th injection level may be considered to be 0 dB:

$$n\text{-th extension layer gain} = \frac{10^{-\text{Injection level \#(n-1)}(\text{dB})/10}}{10^{-\text{Injection level \#n}(\text{dB})/10}} \quad (7)$$

5 **[00384]** The extension layer BICM decoder 660 receives the extension layer symbols whose power has been increased by the de-injection level controller 1150, and restores extension layer data.

10 **[00385]** In this case, the extension layer BICM decoder 660 may include an extension layer symbol demapper, an extension layer bit deinterleaver, and an extension layer error correction decoder. The extension layer symbol demapper calculates LLR values related to the extension layer symbols, the extension layer bit deinterleaver strongly mixes the calculated LLR values with burst errors, and the extension layer error correction decoder corrects error occurring over a channel.

15 **[00386]** In particular, each of the extension layer symbol extractor and the extension layer BICM decoder may include two or more extractors or decoders if two or more extension layers are present.

20 **[00387]** That is, in the example shown in FIG. 12, the extension layer error correction decoder of the extension layer BICM decoder 660 may output only information bits, and may output all bits in which information bits have been combined with parity bits. In this case, the extension layer error correction decoder outputs only information bits as extension layer data, and may output all bits in which information bits have been mixed with parity bits to the subsequent extension layer symbol extractor 670.

25 **[00388]** The configuration and operation of the extension layer symbol extractor 670, the extension layer BICM decoder 680 and the de-injection level controller 1170 can be easily understood from the configuration and operation of the above-described extension layer symbol extractor 650, extension layer BICM decoder 660 and de-injection level controller 1150.

30 **[00389]** A lower one of the de-injection level controllers 1020, 1150 and 1170 shown in FIG. 12 may correspond to a larger increase in power. That is, the de-injection level controller 1150 may increase power more than the de-injection level controller 1020, and the de-injection level controller 1170 may increase power more than the de-injection level controller 1150.

[00390] It can be seen that the signal demultiplexer shown in FIG. 12 restores core layer data first, restores enhanced layer data using the cancellation of core layer symbols, and restores extension layer data using the cancellation of enhanced layer symbols. Two or more extension layers may be provided, in
5 which case restoration starts with an extension layer combined at a higher power level.

[00391] FIG. 13 is a diagram showing an increase in power attributable to the combination of a core layer signal and an enhanced layer signal.

[00392] Referring to FIG. 13, it can be seen that when a multiplexed signal is generated by combining a core layer signal with an enhanced layer signal whose power has been reduced by an injection level, the power level of the multiplexed signal is higher than the power level of the core layer signal or the enhanced layer signal.
10

[00393] In this case, the injection level that is adjusted by the injection level controllers shown in FIGS. 3 and 7 may be adjusted from 0 dB to 25.0 dB in steps of 0.5 dB or 1 dB. When the injection level is 3.0 dB, the power of the enhanced layer signal is lower than that of the core layer signal by 3 dB. When the injection level is 10.0 dB, the power of the enhanced layer signal is lower than that of the core layer signal by 10 dB. This relationship may be applied not only
15 between a core layer signal and an enhanced layer signal but also between an enhanced layer signal and an extension layer signal or between extension layer signals.
20

[00394] The power normalizers shown in FIGS. 3 and 7 may adjust the power level after the combination, thereby solving problems, such as the distortion of the signal, that may be caused by an increase in power attributable to the combination.
25

[00395] FIG. 14 is an operation flowchart showing a method of generating broadcast signal frame according to an embodiment of the present invention.

[00396] Referring to FIG. 14, in the method according to the embodiment of the present invention, BICM is applied to core layer data at step S1210.
30

[00397] Furthermore, in the method according to the embodiment of the present invention, BICM is applied to enhanced layer data at step S1220.

[00398] The BICM applied at step S1220 may be different from the BICM applied to step S1210. In this case, the BICM applied at step S1220 may be less robust than the BICM applied to step S1210. In this case, the bit rate of the BICM applied at step S1220 may be less robust than that of the BICM applied to step S1210.
35

[00399] In this case, an enhanced layer signal may correspond to the enhanced layer data that is restored based on cancellation corresponding to the restoration of the core layer data corresponding to a core layer signal.

5 [00400] Furthermore, in the method according to the embodiment of the present invention, a power-reduced enhanced layer signal is generated by reducing the power of the enhanced layer signal at step S1230.

[00401] In this case, at step S1230, an injection level may be changed from 00 dB to 25.0 dB in steps of 0.5 dB or 1 dB.

10 [00402] Furthermore, in the method according to the embodiment of the present invention, a multiplexed signal is generated by combining the core layer signal and the power-reduced enhanced layer signal at step S1240.

[00403] That is, at step S1240, the core layer signal and the enhanced layer signal are combined at different power levels so that the power level of the enhanced layer signal is lower than the power level of the core layer signal.

15 [00404] In this case, at step S1240, one or more extension layer signals having lower power levels than the core layer signal and the enhanced layer signal may be combined with the core layer signal and the enhanced layer signal.

[00405] Furthermore, in the method according to the embodiment of the present invention, the power of the multiplexed signal is reduced at step S1250.

20 [00406] In this case, at step S1250, the power of the multiplexed signal may be reduced to the power of the core layer signal. In this case, at step S1250, the power of the multiplexed signal may be reduced by a level by which the power has been increased at step S1240.

25 [00407] Furthermore, in the method according to the embodiment of the present invention, a time-interleaved signal is generated by performing time interleaving that is applied to both the core layer signal and the enhanced layer signal is performed at step S1260.

30 [00408] In this case, the step S1260 may use one of time interleaver groups, and a boundary between the time interleaver groups may be a boundary between Physical Layer Pipes (PLPs) of a core layer corresponding to the core layer signal.

[00409] In this case, the step S1260 may use a hybrid time interleaver for performing the interleaving. In this case, Physical Layer Pipes (PLPs) of a core layer and an enhanced layer may include only complete FEC blocks.

35 [00410] In this case, the step S1260 may use a convolutional time interleaver for performing the interleaving, the time interleaver groups may include the Physical Layer Pipe (PLP) which includes an incomplete FEC block, and the

preamble may be for signaling start position information of a first complete FEC block in the Physical Layer Pipe (PLP).

[00411] In this case, the step S1260 may be performed by using one of a plurality of operation modes.

5 [00412] In this case, the operation modes may include a first mode corresponding to no time interleaving, a second mode for performing a Convolutional time interleaving and a third mode for performing a Hybrid time interleaving.

10 [00413] Furthermore, in the method according to the embodiment of the present invention, a broadcast signal frame including a preamble for signaling time interleaver information corresponding to the interleaving is generated at step S1270.

[00414] In this case, the time interleaver information may be signaled on the basis of the core layer.

15 [00415] In this case, the preamble may be for signaling information for identifying a part of a FEC block of the enhanced layer in case that the boundary between the time interleaver groups does not correspond to a boundary between FEC blocks of the enhanced layer, the FEC block corresponding to the boundary between the time interleaver groups.

20 [00416] In this case, the information for identifying the part of the FEC block may include at least one of start position information of a Physical Layer Pipe (PLP) in the core layer, start position information of a Physical Layer Pipe (PLP) in the enhanced layer, modulation information corresponding to the enhanced layer, and FEC type information corresponding to the enhanced layer.

25 [00417] In this case, the start position information of the Physical Layer Pipe (PLP) may correspond to an index of a first data cell of the Physical Layer Pipe (PLP).

[00418] In this case, the modulation information may be signaled only if the FEC type information satisfies a predetermined condition.

30 [00419] In this case, the enhanced layer signal corresponds to enhanced layer data that may be restored based on cancellation corresponding to restoration of core layer data corresponding to the core layer signal.

[00420] In this case, the step S1270 may include generating the bootstrap; generating the preamble; and generating a super-imposed payload corresponding to the time-interleaved signal.

35 [00421] In this case, the preamble may include a PLP identification information for identifying Physical Layer Pipes (PLPs); and a layer

identification information for identifying layers corresponding to division of layers.

5 [00422] In this case, the PLP identification information and the layer identification information may be included in the preamble as fields different from each other.

[00423] In this case, the time interleaver information may be selectively included in the preamble for each of the Physical Layer Pipes (PLPs) based on a result of comparing (IF(j>0)) the layer identification information with a predetermined value.

10 [00424] In this case, the preamble may selectively include an injection level information corresponding to the injection level controller for each of the Physical Layer Pipes (PLPs) based on a result of comparing (IF(j>0)) the layer identification information with a predetermined value.

15 [00425] In this case, the bootstrap may be shorter than the preamble, and have a fixed-length.

[00426] In this case, the bootstrap may include a symbol representing a structure of the preamble, the symbol corresponding to a fixed-length bit string representing a combination of a modulation scheme/code rate, a FFT size, a guard interval length and a pilot pattern of the preamble.

20 [00427] In this case, the symbol may correspond to a lookup table in which a preamble structure corresponding to a second FFT size is allocated prior to a preamble structure corresponding to a first FFT size, the second FFT size being less than the first FFT size when the modulation scheme/code rates are the same, and a preamble structure corresponding to a second guard interval length is allocated prior to a preamble structure corresponding to a first guard interval length, the second guard interval length being longer than the first guard interval length when the modulation scheme/code rates are the same and the FFT sizes are the same.

[00428] In this case, the broadcast signal frame may be an ATSC 3.0 frame.

30 [00429] In this case, the L1 signaling information may include injection level information and/or normalizing factor information.

[00430] In this case, the preamble may include type information, start position information and size information of the Physical Layer Pipes

35 [00431] In this case, the type information may be for identifying one among a first type corresponding to a non-dispersed physical layer pipe and a second type corresponding to a dispersed physical layer pipe.

[00432] In this case, the non-dispersed physical layer pipe may be assigned for contiguous data cell indices, and the dispersed physical layer pipe may include two or more subslices.

5 [00433] In this case, the type information may be selectively signaled according to a result of comparing the layer identification information with a predetermined value for each of the Physical Layer Pipes (PLPs).

[00434] In this case, the type information may be signaled only for the core layer.

10 [00435] In this case, the start position information may be identical to an index corresponding to the first data cell of the physical layer pipe.

[00436] In this case, the start position information may indicate the start position of the physical layer pipe using cell addressing scheme.

15 [00437] In this case, the start position information may be included in the preamble for each of the Physical Layer Pipes (PLPs) without checking a condition of a conditional statement corresponding to the layer identification information.

[00438] In this case, the size information may be generated based on the number of data cells assigned to the physical layer pipe.

20 [00439] In this case, the size information may be included in the preamble for each of the Physical Layer Pipes (PLPs) without checking a condition of a conditional statement corresponding to the layer identification information.

25 [00440] In this case, the preamble may include a field indicating a start position of a first complete FEC block corresponding to a current Physical Layer Pipe for the first mode and the second mode, and may not include the field indicating the start position of the first FEC block for the third mode.

[00441] In this case, the field indicating the start position of the first FEC block may be one of a first field used in the first mode and a second field used in the second mode, and the first field and the second field may have different lengths.

30 [00442] In this case, the length of the second field may be longer than the length of the first field.

35 [00443] In this case, the length of the first field may be determined based on a length of a LDPC codeword and a modulation order and the length of the second field may be determined not only by the length of the LDPC codeword and the modulation order but also by further considering a depth of a Convolutional time interleaver.

[00444] In this case, the length of the first field may be 15 bits and the length of the second field may be 22 bits.

[00445] In this case, the first field and the second field may be separately signaled for each of a core layer corresponding to the core layer signal and an enhanced layer corresponding to the enhanced layer signal.

[00446] Although not explicitly shown in FIG. 14, the method may further include the step of generating signaling information including injection level information corresponding to step S1230. In this case, the signaling information may be L1 signaling information.

[00447] In this case, the injection level information may be signaled by using 31 values which are identified using a 5 bit-field.

[00448] In this case, step S1250 may correspond to a normalizing factor which increases as a power reduction corresponding to the power reduced enhanced layer signal becomes larger, and step S1230 may correspond to a scaling factor which decreases as the power reduction corresponding to the power reduced enhanced layer signal becomes larger.

[00449] In this case, the 31 values may be matched with 5 bit field values belonging to any one of a first section corresponding to a first step size and a second section corresponding to a second step size, the second step size being different from the first step size.

[00450] In this case, the first section may correspond to a first rate of change of the scaling factor and the second section may correspond to a second rate of change of the scaling factor, the second rate of change being less than the first rate of change.

[00451] In this case, the first section may correspond to a section from 0 dB to 5 dB and the second section may correspond to a section from 6 dB to 25 dB.

[00452] In this case, the first step size may be 0.5 dB and the second step size may be 1 dB.

[00453] In this case, the first section may include 5 bit-field values belonging to a section of 0 dB (inclusive) ~ 3 dB (exclusive) and the second section may include 5 bit-field values belonging to a section of 10 dB (exclusive) ~ 25 dB (inclusive).

[00454] In this case, the preamble may include layer identification information for identifying layers corresponding to a hierarchical division.

[00455] In this case, the preamble may selectively include the injection level information according to a result of comparing the layer identification information with a predetermined value for each of Physical Layer Pipes (PLPs).

[00456] The method of generating broadcast signal frame shown in FIG. 14 may correspond to step S210 shown in FIG. 2.

[00457] FIG. 15 is a diagram showing a structure of a super-frame which includes broadcast signal frames according to an embodiment of the present invention.

[00458] Referring to FIG. 15, the super-frame based on the Layered Division Multiplexing (LDM) configures at least one of frame, and each frame configures at least one of OFDM symbol.

[00459] In this case, each OFDM symbol may start with at least one preamble symbol. Moreover, the frame may include a reference symbol or a pilot symbol.

[00460] The super-frame 1510 illustrated in FIG. 15, may include a LDM frame 1520, a single layer frame without LDM 1530 and a Future Extension Frame (FEF) for future extensibility 1540 and may be configured using Time Division Multiplexing (TDM).

[00461] The LDM frame 1520 may include an Upper Layer (UL) 1553 and a Lower Layer (LL) 1555 when two layers are applied.

[00462] In this case, the upper layer 1553 may correspond to the core layer and the lower layer 1555 may correspond to the enhanced layer.

[00463] In this case, the LDM frame 1520 which includes the upper layer 1553 and the lower layer 1555 may include a bootstrap 1552 and a preamble 1551.

[00464] In this case, the upper layer data and the lower layer data may share the time interleaver for reducing complexity and memory size and may use the same frame length and FFT size.

[00465] Moreover, the single-layer frame 1530 may include the bootstrap 1562 and the preamble 1561.

[00466] In this case, the single-layer frame 1530 may use a FFT size, time interleaver and frame length different from the LDM frame 1520. In this case, the single-layer frame 1530 may be multiplexed with the LDM frame 1520 in the super-frame 1510 based on TDM scheme.

[00467] FIG. 16 is a diagram showing an example of a LDM frame using LDM of two layers and multiple-physical layer pipes.

[00468] Referring to FIG. 16, the LDM frame starts with a bootstrap signal including version information of the system or general signaling information. The L1 signaling signal which includes code rate, modulation information, number information of physical layer pipes may follow the bootstrap as a preamble.

[00469] The common Physical Layer Pipe (PLP) in a form of burst may be transferred following the preamble (L1 SIGNAL). In this case, the common physical layer pipe may transfer data which can be shared with other physical layer pipes in the frame.

5 **[00470]** The Multiple-Physical Layer Pipes for servicing broadcasting signals which are different from each other may be transferred using LDM scheme of two layers. In this case, the service (720p or 1080p HD, etc.) which needs robust reception performance such as indoor/mobile may use the core layer (upper layer) data physical layer pipes. In this case, the fixed reception service
10 (4K-UHD or multiple HD, etc.) which needs high transfer rate may use the enhanced layer (lower layer) data physical layer pipes.

[00471] If the multiple physical layer pipes are layer-division-multiplexed, it can be seen that the total number of physical layer pipes increases.

[00472] In this case, the core layer data physical layer pipe and the enhanced layer data physical layer pipe may share the time interleaver for reducing complexity and memory size. In this case, the core layer data physical layer pipe and the enhanced layer data physical layer pipe may have the same physical layer pipe size (PLP size), and may have physical layer pipe sizes different from each other.
15

20 **[00473]** In accordance with the embodiments, the layer-divided PLPs may have PLP sizes different from one another, and information for identifying the start position of the PLP or information for identifying the size of the PLP may be signaled.

[00474] FIG. 17 is a diagram showing another example of a LDM frame using LDM of two layers and multiple-physical layer pipes.
25

[00475] Referring to FIG. 17, the LDM frame may include the common physical layer pipe after the bootstrap and the preamble (L1 SIGNAL). The core layer data physical layer pipes and the enhanced layer data physical layer pipes may be transferred using two-layer LDM scheme after the common physical layer pipe.
30

[00476] In particular, the core layer data physical layer pipes and the enhanced layer data physical layer pipes of FIG. 17 may correspond to one type among type 1 and type 2. The type 1 and the type 2 may be defined as follows:

[00477] – Type 1 PLP

35 **[00478]** It is transferred after the common PLP if the common PLP exists

[00479] It is transferred in a form of burst (one slice) in the frame

[00480] – Type 2 PLP

[00481] It is transferred after the type 1 PLP if the type 1 PLP exists

[00482] It is transferred in a form of two or more sub-slices in the frame

[00483] The time diversity and the power consumption increase as the number of sub-slices increases

5 **[00484]** In this case, the type 1 PLP may correspond to a non-dispersed PLP, and the type 2 PLP may correspond to a dispersed PLP. In this case, the non-dispersed PLP may assigned for contiguous data cell indices. In this case, the dispersed PLP may assigned to two or more subslices.

10 **[00485]** FIG. 18 is a diagram showing an application example of LDM frame using LDM of two layers and multiple physical layer pipes.

[00486] Referring to FIG. 18, the common physical layer pipe (PLP(1,1)) may be included after the bootstrap and the preamble in the LDM frame. The data physical layer pipe (PLP(2,1)) for robust audio service may be included in the LDM frame using the time-division scheme.

15 **[00487]** Moreover, the core layer data physical layer pipe (PLP(3,1)) for mobile/indoor service (720p or 1080p HD) and the enhanced layer data physical layer pipe (PLP(3,2)) for high data rate service (4K-UHD or multiple HD) may be transferred using 2-layer LDM scheme.

20 **[00488]** FIG. 19 is a diagram showing another application example of a LDM frame using LDM of two layers and multiple physical layer pipes.

[00489] Referring to FIG. 19, the LDM frame may include the bootstrap, the preamble, the common physical layer pipe (PLP(1,1)). In this case, the robust audio service and mobile/indoor service (720p or 1080p HD) may be transferred using core layer data physical layer pipes (PLP(2,1),PLP(3,1)), and the high data rate service (4K-UHD or multiple HD) may be transferred using the enhanced layer data physical layer pipes (PLP(2,2),PLP(3,2)).

25 **[00490]** In this case, the core layer data physical layer pipe and the enhanced layer data physical layer pipe may use the same time interleaver.

30 **[00491]** In this case, the physical layer pipes (PLP(2,2),PLP(3,2)) which provide the same service may be identified using the PLP_GROUP_ID indicating the same PLP group.

[00492] In accordance with the embodiment, the service can be identified using the start position and the size of each physical layer pipe without PLP_GROUP_ID when the physical layer pipes which have sizes different from each other for different LDM layers are used.

35 **[00493]** Although multiple physical layer pipes and layers corresponding to the layer division multiplexing are identified by PLP(i,j) in FIG. 18 and FIG. 19,

the PLP identification information and the layer identification information may be signaled as fields different from each other.

[00494] In accordance with the embodiment, different layers may use PLPs having different sizes. In this case, each service may be identified using the PLP identifier.

[00495] The PLP start position and the PLP size may be signaled for each PLP when PLPs having different sizes are used for different layers.

[00496] The following pseudo code is for showing an example of fields included in the preamble according to an embodiment of the present invention. The following pseudo code may be included in the L1 signaling information of the preamble.

```

[00497] [Pseudo Code]
SUB_SLICES_PER_FRAME (15 bits)
NUM_PLP (8 bits)
15 NUM_AUX (4 bits)
AUX_CONFIG_RFU (8 bits)

for i=0.. NUM_RF-1 {
RF_IDX (3 bits)
20 FREQUENCY (32 bits)
}

IF S2=='xxx1' {
FEF_TYPE (4 bits)
25 FEF_LENGTH (22 bits)
FEF_INTERVAL (8 bits)
}

for i=0 .. NUM_PLP-1 {
30 NUM_LAYER (2~3 bits)
for j=0 .. NUM_LAYER-1{
/* Signaling for each layer */
PLP_ID (i, j) (8 bits)
PLP_GROUP_ID (8 bits)
35 PLP_TYPE (3 bits)
PLP_PAYLOAD_TYPE (5 bits)
PLP_COD (4 bits)
PLP_MOD (3 bits)
PLP_SSD (1 bit)
40 PLP_FEC_TYPE (2 bits)

```

```

    PLP_NUM_BLOCKS_MAX                (10 bits)
    IN_BAND_A_FLAG                    (1 bit)
    IN_BAND_B_FLAG                    (1 bit)
    PLP_MODE                          (2 bits)
5   STATIC_PADDING_FLAG              (1 bit)
    IF (j > 0)
        LL_INJECTION_LEVEL            (3-8 bits)
    } /* End of NUM_LAYER loop */

10  /* Common signaling for all layers */
    FF_FLAG                          (1 bit)
    FIRST_RF_IDX                      (3 bits)
    FIRST_FRAME_IDX                  (8 bits)
    FRAME_INTERVAL                   (8 bits)
15  TIME_IL_LENGTH                   (8 bits)
    TIME_IL_TYPE                     (1 bit)
    RESERVED_1                       (11 bits)
    STATIC_FLAG                      (1 bit)
    PLP_START                        (24 bits)
20  PLP_SIZE                         (24 bits)
    } /* End of NUM_PLP loop */

    FEF_LENGTH_MSB                  (2 bits)
    RESERVED_2                      (30 bits)
25
    for i=0 .. NUM_AUX-1 {
        AUX_STREAM_TYPE              (4 bits)
        AUX_PRIVATE_CONF             (28 bits)
    }
30  [00498]    The NUM_LAYER may correspond to two bits or three bits in the
    above pseudo code. In this case, the NUM_LAYER may be a field for
    identifying the number of layers in each PLP which is divided in time. In this
    case, the NUM_LAYER may be defined in the NUM_PLP loop so that the
    number of the layers can be different for each PLP which is divided in time.

35  [00499]    The LL_INJECTION_LEVEL may correspond to 3~8 bits. In this
    case, the LL_INJECTION_LEVEL may be a field for identifying the injection
    level of the lower layer (enhanced layer). In this case, the
    LL_INJECTION_LEVEL may correspond to the injection level information.

[00500]    In this case, the LL_INJECTION_LEVEL may be defined from the
40  second layer (j>0) when the number of layers is two or more.

```

5 [00501] The fields such as PLP_ID(i,j), PLP_GROUP_ID, PLP_TYPE, PLP_PAYLOAD_TYPE, PLP_COD, PLP_MOD, PLP_SSD, PLP_FEC_TYPE, PLP_NUM_BLOCKS_MAX, IN_BAND_A_FLAG, IN_BAND_B_FLAG, PLP_MODE, STATIC_PADDING_FLAG, etc. may correspond to parameters which are defined for each layer, and may be defined inside of the NUM_LAYER loop.

10 [00502] In this case, the PLP_ID(i,j) may correspond to the PLP identification information and the layer identification information. For example, the 'i' of the PLP_ID(i,j) may correspond to the PLP identification information and the 'j' of the PLP_ID(i,j) may correspond to the layer identification information.

[00503] In accordance with embodiments, the PLP identification information and the layer identification information may be included in the preamble as fields different from each other.

15 [00504] Moreover, the time interleaver information such as the TIME_IL_LENGTH and TIME_IL_TYPE, etc., the FRAME_INTERVAL which is related to the PLP size and fields such as FF_FLAG, FIRST_RF_IDX, FIRST_FRAME_IDX, RESERVED_1, STATIC_FLAG, etc. may be defined outside of the NUM_LAYER loop and inside of the NUM_PLP loop.

20 [00505] In particular, the PLP_TYPE corresponds to type information of the physical layer pipes and may correspond to 1 bit for identifying one among two types, type 1 and type 2. The PLP_TYPE is included in the preamble without checking a condition of a conditional statement corresponding to the layer identification information (j) in the above pseudo code, but the PLP_TYPE may be selectively signaled (transferred only for the core layer) based on a result (if(j=0)) of comparing the layer identification information (j) with a predetermined value (0).

30 [00506] The PLP_TYPE is defined in the NUM_LAYER loop in the above pseudo code, but the PLP_TYPE may be defined outside of the NUM_LAYER loop and inside of the NUM_PLP loop.

35 [00507] In the above pseudo code, the PLP_START corresponds to a start position of the corresponding physical layer pipe. In this case, the PLP_START may identify the start position using cell addressing scheme. In this case, the PLP_START may be an index corresponding to a first data cell of the corresponding PLP.

[00508] In particular, the PLP_START may be signaled for every physical layer pipe and may be used for identifying services using the multiple-physical layer pipes together with a field for signaling the size of the PLP.

5 **[00509]** The PLP_SIZE in the above pseudo code corresponds to size information of the physical layer pipes. In this case, the PLP_SIZE may be identical to the number of data cells assigned to the corresponding physical layer pipe.

10 **[00510]** That is, the PLP_TYPE may be signaled based on the layer identification information and the PLP_SIZE and the PLP_START may be signaled for every physical layer pipe without considering the layer identification information.

15 **[00511]** The combiner 340 shown in FIG. 3 and FIG. 7 functions to combine the core layer signal and the enhanced layer signal, and the combining may be performed on a time interleaver group basis shared by the core layer signal and the enhanced layer signal because the core layer signal and the enhanced layer signal share one time interleaver.

[00512] In this case, the time interleaver group may be set based on the core layer in terms of memory efficiency and system efficiency.

20 **[00513]** However, when a time interleaver group is set based on the core layer, there may exist a FEC block that is divided by the time interleaver group boundary in the enhanced layer. If such a FEC block which is divided exist, signaling of fields for identifying a portion of the FEC block corresponding to the time interleaver group boundary may be required.

25 **[00514]** The time interleaver for the Layered Division Multiplexing may be a convolutional time interleaver (CTI) or a hybrid time interleaver (HTI). In this case, the convolutional time interleaver may be used when there is one Physical Layer Pipe in the core layer, and the hybrid time interleaver may be used when there are two or more Physical Layer Pipes in the core layer. When the hybrid time interleaver is used, the Physical Layer Pipes may include only complete FEC
30 blocks.

[00515] FIG. 20 is a diagram showing an example in which a convolutional time interleaver is used.

[00516] Referring to FIG. 20, the subframe includes two layers, the core layer and the enhanced layer.

35 **[00517]** As the subframe includes only one Physical Layer Pipe (PLP #0) in the core layer in the example shown in FIG. 20, the time interleaver corresponding to the subframe is a convolutional time interleaver. The Physical

Layer Pipes in each layer may include an incomplete FEC block when the convolutional time interleaver is used.

5 [00518] Such an incomplete FEC block is located at the edge of the PLP and can be identified using a field such as "L1D_plp_CTI_fec_block_start" indicating the position of the first complete FEC block in each PLP.

[00519] In the example shown in FIG. 20, the Physical Layer Pipe (PLP #0) of the core layer and the Physical Layer Pipe (PLP #1) of the enhanced layer have the same start position and size.

10 [00520] In the example shown in FIG. 20, it can be seen that the time interleaver group (TI Group) corresponds to the Physical Layer Pipe (PLP #0) of the core layer. The time interleaver group is commonly applied to the core layer and the enhanced layer, and it is advantageous in terms of memory and system efficiency to be set corresponding to the core layer.

15 [00521] FIG. 21 is a diagram showing another example in which a convolutional time interleaver is used.

[00522] Referring to FIG. 21, it can be seen that the starting positions and sizes of the core layer physical layer pipe (PLP #0) and the enhanced layer physical layer pipe (PLP #1) are different.

20 [00523] If the start position and the size of the core layer physical layer pipe (PLP #0) and the start position and the size of the enhanced layer physical layer pipe (PLP #1) are different from each other, an empty area may be included in the enhanced layer.

25 [00524] As shown in FIG. 21, when the empty area is included at the rear end of the enhanced layer physical layer pipe (PLP #1), the enhanced layer physical layer pipe (PLP #1) is ended with a complete FEC block.

[00525] FIG. 22 is a diagram showing an example in which a hybrid time interleaver is used.

30 [00526] Referring to FIG. 22, two Physical Layer Pipes (PLP #0, PLP #1) are included in the core layer.

[00527] Thus, when the core layer is composed of multiple Physical Layer Pipes, a hybrid time interleaver is used.

[00528] When a hybrid time interleaver is used, all Physical Layer Pipes of the core layer and the enhanced layer include only complete FEC blocks.

35 [00529] In this case, some parts of the enhanced layer may be emptied for alignment with the core layer boundary.

[00530] FIG. 23 is a diagram showing time interleaver groups in the example of FIG. 22.

[00531] Referring to FIG. 23, it can be seen that the time interleaver group boundaries are set corresponding to the boundaries of the Physical Layer Pipes of the core layer.

5 [00532] Although the time interleaver group includes one core layer physical layer pipe in FIG. 23, according to an embodiment, the time interleaver group may include two or more core layer physical pipes.

[00533] In the example shown in FIG. 23, one FEC block of the enhanced layer may be divided by the time interleaver group boundary.

10 [00534] This is because time interleaver group partitioning is performed on a core layer basis, in which case it is possible to signal information for identifying an incomplete FEC block of the enhanced layer, the incomplete FEC block corresponding to the time interleaver group boundary.

[00535] FIGS. 24 to 26 are diagrams showing a process of calculating the size of an incomplete FEC block in the example of FIG. 23.

15 [00536] Referring to FIG. 24, the distance (A) between the start position of the enhanced layer physical layer pipe (L1D_plp_start(PLP #2)) and the time interleaver group boundary is calculated using the start position of the core layer physical layer pipe (L1D_plp_start(PLP #0)), the size of the core layer physical layer pipe (L1D_plp_size(PLP #0)) and the start position of the enhanced layer physical layer pipe (L1D_plp_start(PLP #2)).

20 [00537] Referring to FIG. 25, the distance (B) between the start position of the divided FEC block and the time interleaver group boundary is calculated using the FEC block size of the enhanced layer.

25 [00538] In this case, the FEC block size may be decided by using the modulation information (L1D_plp_mod) corresponding to the enhanced layer and the FEC type information (L1D_plp_fec_type) corresponding to the enhanced layer.

30 [00539] Referring to FIG. 26, the part (C) of the FEC block of the enhanced layer corresponding to the boundary between the time interleaver groups is identified.

[00540] Table 3 below shows an example of L1-Detail fields of the preamble according to an embodiment of the present invention.

[00541] The preamble according to an embodiment of the present invention may include L1-Basic and L1-Detail.

35 Table 3

Syntax	# of bits
L1_Detail_signaling() {	

L1D_version	4
L1D_num_rf	3
for L1D_rf_id=1 .. L1D_num_rf {	
L1D_rf_frequency	19
}	
if (L1B_time_info_flag != 00) {	
L1D_time_sec	32
L1D_time_msec	10
if (L1B_time_info_flag != 01) {	
L1D_time_usec	10
if (L1B_time_info_flag != 10) {	
L1D_time_nsec	10
}	
}	
}	
for i=0 .. L1B_num_subframes {	
if (i > 0) {	
L1D_mimo	1
L1D_miso	2
L1D_fft_size	2
L1D_reduced_carriers	3
L1D_guard_interval	4
L1D_num_ofdm_symbols	11
L1D_scattered_pilot_pattern	5
L1D_scattered_pilot_boost	3
L1D_sbs_first	1
L1D_sbs_last	1
}	
if (L1B_num_subframes>0) {	
L1D_subframe_multiplex	1
}	
L1D_frequency_interleaver	1
L1D_num_plp	6
for j=0 .. L1D_num_plp {	
L1D_plp_id	6
L1D_plp_lls_flag	1
L1D_plp_layer	2
L1D_plp_start	24
L1D_plp_size	24
L1D_plp_scrambler_type	2
L1D_plp_fec_type	4

if (L1D_plp_fec_type ∈ {0,1,2,3,4,5}) {	
L1D_plp_mod	4
L1D_plp_cod	4
}	
L1D_plp_TI_mode	2
if (L1D_plp_TI_mode=00) {	
L1D_plp_fec_block_start	15
}	
if (L1D_plp_TI_mode=01) {	
L1D_plp_CTI_fec_block_start	22
}	
if (L1D_num_rf>0) {	
L1D_plp_num_channel_bonded	3
if (L1D_plp_num_channel_bonded>0) {	
L1D_plp_channel_bonding_format	2
for k=0 ..	
L1D_plp_num_channel_bonded{	
L1D_plp_bonded_rf_id	3
}	
}	
}	
if (i=0 && L1B_first_sub_mimo=1) (i >1 && L1D_mimo=1) {	
L1D_plp_stream_combining	1
L1D_plp_IQ_interleaving	1
L1D_plp_PH	1
}	
if (L1D_plp_layer=0) {	
L1D_plp_type	1
if L1D_plp_type=1 {	
L1D_plp_num_subslices	14
L1D_plp_subslice_interval	24
}	
L1D_plp_TI_extended_interleaving	1
if (L1D_plp_TI_mode=01) {	
L1D_plp_CTI_depth	3
L1D_plp_CTI_start_row	11
} else if (L1D_plp_TI_mode=10) {	
L1D_plp_HTI_inter_subframe	1

L1D_plp_HTI_num_ti_blocks	4
L1D_plp_HTI_num_fec_blocks_max	12
if	
(L1D_plp_HTI_inter_subframe=0) {	
L1D_plp_HTI_num_fec_blocks	12
} else {	
for (k=0..	
L1D_plp_HTI_num_ti_blocks) {	
L1D_plp_HTI_num_fec_blocks	12
}	
}	
L1D_plp_HTI_cell_interleaver	1
}	
} else {	
L1D_plp_ldm_injection_level	5
}	
}	
}	
L1D_reserved	as needed
L1D_crc	32
}	

[00542] All fields corresponding to assigned bits in Table 3 may correspond to unsigned integer most significant bit first (uimsbf) format.

[00543] Among fields in Table 3, L1D_plp_layer may be a field for representing a layer corresponding to each physical layer pipe. L1D_plp_start may correspond to start position information of the current PLP, and may indicate an index of the first data cell of the current PLP. L1D_plp_size may correspond to size information of the current PLP, and may indicate the number of data cells allocated to the current PLP.

[00544] L1D_plp_fec_type may correspond to FEC type information of the current PLP, and may indicate the Forward Error Correction (FEC) method used for encoding the current PLP.

[00545] For example, L1D_plp_fec_type="0000" may correspond to BCH and 16200 LDPC, L1D_plp_fec_type="0001" may correspond to BCH and 64800 LDPC, L1D_plp_fec_type="0010" may correspond to CRC and 16200 LDPC, L1D_plp_fec_type="0011" may correspond to CRC and 64800 LDPC, L1D_plp_fec_type="0100" may correspond to 16200 LDPC, and L1D_plp_fec_type="0101" may correspond to 64800 LDPC.

[00546] L1D_plp_mod may indicate modulation information of the current PLP. In this case, L1D_plp_mod may be signaled only if L1D_plp_fec_type satisfies a predetermined condition as shown in Table 3.

[00547] For example, L1D_plp_mod="0000" may correspond to QPSK, L1D_plp_mod="0001" may correspond to 16QAM-NUC, L1D_plp_mod="0010" may correspond to 64QAM-NUC, L1D_plp_mod="0011" may correspond to 256QAM-NUC, L1D_plp_mod="0100" may correspond to 1024QAM-NUC and L1D_plp_mod="0101" may correspond to 4096QAM-NUC. In this case, L1D_plp_mod can be set to "0100" or "0101" only if L1D_plp_fec_type corresponds to 64800 LDPC.

[00548] L1D_plp_TI_mode indicates the time interleaving mode of the PLP.

[00549] For example, L1D_plp_TI_mode="00" may represent no time interleaving mode, L1D_plp_TI_mode="01" may represent convolutional time interleaving mode and L1D_plp_TI_mode="10" may represent hybrid time interleaving mode.

[00550] L1D_plp_fec_block_start may correspond to start position information of the first complete FEC block in the physical layer pipe. L1D_plp_fec_block_start may be signaled only if L1D_plp_TI_mode="00".

[00551] When the Layered Division Multiplexing is used, L1D_plp_fec_block_start may be signaled separately for each layer since the start positions of the first FEC blocks in each layer can be different.

[00552] L1D_plp_CTI_fec_block_start may correspond to start position information of the first complete block in the physical layer pipe. L1D_plp_CTI_fec_block_start may be signaled only if L1D_plp_TI_mode="01".

[00553] In this case, more bits may be allocated to L1D_plp_CTI_fec_block_start than L1D_plp_fec_block_start.

[00554] As described above, when L1D_plp_TI_mode="10", all PLPs include only the complete FEC blocks, so there is no need to separately signal the start position of the first FEC block.

[00555] L1D_plp_HTI_num_fec_blocks may correspond to the number of FEC blocks contained in the current interleaving frame for the physical layer pipe of the core layer.

[00556] In this case, it can be seen that each of fields (L1D_plp_CTI_depth, L1D_plp_CTI_start_row) corresponding to a Convolutional time interleaving and fields (L1D_plp_HTI_inter_subframe, L1D_plp_HTI_num_ti_blocks, L1D_plp_HTI_num_fec_blocks_max, L1D_plp_HTI_num_fec_blocks, L1D_plp_HTI_cell_interleaver, etc.) corresponding to a Hybrid time interleaving

according to whether L1D_plp_TI_mode is 01 or 10 when L1D_plp_layer is 0 (core layer) are signaled as the time interleaver information.

[00557] In this case, L1D_plp_CTI_depth may indicate the number of rows used in the Convolutional time interleaver and L1D_plp_CTI_start_row may indicate the position of interleaver selector at the start of the subframe.

[00558] In this case, L1D_plp_HTI_inter_subframe may indicate the Hybrid time interleaving mode, and L1D_plp_HTI_num_ti_blocks may indicate the number of TI blocks per interleaving frame or the number of subframes over which cells from one TI block are carried, and L1D_plp_HTI_num_fec_blocks_max may indicate one less than the maximum number of FEC blocks per interleaving frame for the current Physical Layer Pipe, and L1D_plp_HTI_num_fec_blocks may indicate one less than the number of FEC blocks contained in the current interleaving frame for the current Physical Layer Pipe, and L1D_plp_HTI_cell_interleaver may indicate whether the cell interleaver is used or not.

[00559] In this case, a field such as L1D_plp_TI_mode may be signaled separately from the time interleaver information signaled based on the core layer.

[00560] FIG. 27 is a diagram for explaining the number of bits required for L1D_plp_fec_block_start when L1D_plp_TI_mode="00".

[00561] Referring to FIG. 27, it can be seen that cell address of FEC block start position before time interleaving (C_in) and cell address of FEC block start position after time interleaving (C_out) are identical when L1D_plp_TI_mode="00" (no time interleaving).

[00562] In the case of no time interleaving as FIG. 27, it can be seen that the Convolutional interleaving is performed with a depth of 0.

[00563] In this case, L1D_plp_fec_block_start is defined after time interleaving so that C_out may be signaled as L1D_plp_fec_block_start for each Physical Layer Pipe in the subframe.

[00564] The longest FEC block may have a length of $64800/2 = 32400$ when the LDPC codeword is 16200 or 64800 and the modulation order is 2, 4, 6, 8, 10 and 12.

[00565] As 32400 can be expressed by 15 bits, assigning 15 bits to L1D_plp_fec_block_start may cover the case of L1D_plp_TI_mode = "00".

[00566] FIGS. 28 and 29 are diagrams for explaining the number of bits required for L1D_plp_CTI_fec_block_start when L1D_plp_TI_mode = "01".

[00567] Referring to FIG. 28, it can be seen that cell address of FEC block start position before time interleaving (C_in) and cell address of FEC block start

position after time interleaving (C_{out}) are different because of interleaving when $L1D_plp_TI_mode="01"$ (Convolutional time interleaving).

5 **[00568]** In this case, $L1D_plp_CTI_fec_block_start$ is defined after time interleaving so that C_{out} may be signaled as $L1D_plp_CTI_fec_block_start$ for each Physical Layer Pipe in the subframe.

[00569] Referring to FIG. 29, it can be seen that a convolutional time interleaver having a depth of 4 operates with C_{in} as an input and C_{out} as an output.

10 **[00570]** In this case, 0 corresponds to the 0th row, 1 corresponds to the 1st row, 2 corresponds to the 2nd row, 3 corresponds to the 3rd row, 4 corresponds to the 0th row, 5 corresponds to the 1st row, 6 corresponds to the 2nd row, 7 corresponds to the 3rd row, 8 corresponds to the 0th row, 9 corresponds to the 1st row, 10 corresponds to the 2nd row in the case of the input.

15 **[00571]** At First, 0, 4, 8, etc. corresponding to the 0th row are output without delay.

[00572] 1, 5, 9, etc. corresponding to the 1st row are output with 4 delays.

[00573] 2, 6, 10, etc. corresponding to the 2nd row are output with 8 delays.

[00574] 3, 7, etc. corresponding to the 3rd row are output with 12 delays.

[00575] That is, it can be seen that $(n \times 4)$ delays occur for the n -th row.

20 **[00576]** Although the example of depth 4 (the number of rows of the time interleaver is 4) is explained in FIG. 29, the input corresponding to the n -th row is delayed by $(n \times N_{row})$ when the number of rows of the time interleaver is N_{row} .

25 **[00577]** In this case, cell address of FEC block start position after time interleaving ($L1D_plp_CTI_fec_block_start$) may be calculated as $(C_{in} + (n \times N_{row}))$. In this case, n is a row corresponding to C_{in} and may be determined by $L1D_CTI_start_row$ among the time interleaving information signaled by L1-Detail. In this case, n may be $((L1D_CTI_start_row + C_{in}) \% N_{row})$. In this case, $L1D_CTI_start_row$ may indicate the position of the interleaver selector at the start of the subframe.

30 **[00578]** That is, $L1D_plp_CTI_fec_block_start$ can be calculated by adding a delay caused by time interleaving to C_{in} .

35 **[00579]** To calculate the number of bits required for signaling $L1D_plp_CTI_fec_block_start$, the maximum value of $L1D_plp_CTI_fec_block_start$ is required. As already shown above, the maximum value of C_{in} is 32400, the maximum value of n is $N_{row}-1$ and N_{row} may be 1024 at most in the case of non-extended interleaving. In this

case, the maximum value of L1D_plp_CTI_fec_block_start is $(32400 + (1024-1) \times 1024) = 1079952$. 1079952 can be signaled using at least 21 bits.

[00580] N_row may be 1448 at most in the case of extended interleaving. In this case, the maximum value of L1D_plp_CTI_fec_block_start is $(32400 + (1448-1) \times 1448) = 2127656$. 2127656 can be signaled using at least 22 bits.

[00581] Accordingly, since the maximum value of L1D_plp_fec_block_start is identical to the maximum value of C_in when L1D_plp_TI_mode="00" and the maximum value of L1D_plp_CTI_fec_block_start is the sum of the maximum value of C_in and the delay due to the interleaving when L1D_plp_TI_mode="01", an efficient signaling is possible when the number of bits used for signaling L1D_plp_CTI_fec_block_start is larger than the number of bits used for signaling L1D_plp_fec_block_start.

[00582] Since all Physical Layer Pipes of the core layer and the enhanced layer include only complete FEC blocks when L1D_plp_TI_mode="10", the start position of all Physical Layer Pipes becomes the start position of the first complete FEC block so that there is no need to signal the field such as L1D_plp_fec_block_start or L1D_plp_CTI_fec_block_start.

Table 4

	Data rate	ModCod	SNR before LDM	SNR after LDM (injection level = 4dB)
Core Layer	2.7 Mbps	QPSK & 4/15	-2.9 dB	-0.5 dB
Enhanced Layer	20.5 Mbps	64QAM & 10/15	12.9 dB	18.4 dB

[00583] Table 4 is a table showing an example in which more robust mobile/indoor service is used for the core layer and less robust fixed service is used for the enhanced layer.

[00584] FIG. 30 is a diagram showing a core layer signal and an enhanced layer signal in case of the example of Table 4.

[00585] In the example shown in Table 4 and FIG. 30, the core layer signal may be more robust than the enhanced layer signal and injection level may be set in the range of about 3 dB to 10 dB.

Table 5

	Data rate	ModCod	SNR before LDM	SNR after LDM (injection level = 19dB)
Core Layer	22.0 Mbps	256QAM & 8/15	13.9 dB	15.5 dB
Enhanced Layer	2.7 Mbps	QPSK & 4/15	-2.7 dB	16.3 dB

[00586] Table 5 is a table showing an example in which less robust fixed service is used for the core layer and more robust local service is used for the enhanced layer for the LDM based local service.

5 [00587] FIG. 31 is a diagram showing a core layer signal and an enhanced layer signal in case of the example of Table 5.

[00588] In the example shown in Table 5 and FIG. 31, the core layer may be used for the digital TV broadcast, and the enhanced layer may be used for the local service (for example, local advertising, non-real time service, etc.) which is capable of transmitting different contents from each regional transmitter.

10 [00589] The enhanced layer operates at negative SNR so that seamless switching between local services may be possible in regions where signals of different local services overlap such as cloud transmission.

[00590] In this case, an injection level which is larger than the operation SNR of the core layer may be required for decoding of the core layer.

15 [00591] In this case, an injection level from about 10 dB to 25 dB may be required in order that the enhanced layer and the core layer have the same coverage.

20

Table 6

	Data rate	ModCod	SNR before LDM	SNR after LDM (injection level = 19dB)
Core Layer #1	16.4 Mbps	256QAM & 8/15	13.9 dB	15.5 dB
Core Layer #2	1.9 Mbps	QPSK & 11/15	3.4 dB	3.5 dB
Enhanced Layer	2.7 Mbps	QPSK & 4/15	-2.7 dB	16.3 dB

[00592] Table 6 is a table showing an example in which less robust fixed service and mobile service are used for the core layer and more robust local service is used for the enhanced layer for the LDM based local service.

25 [00593] FIG. 32 is a diagram showing a core layer signal and an enhanced layer signal in case of the example of Table 6.

[00594] In the example shown in Table 6 and FIG. 32, the fixed service and the mobile service which are multiplexed with the core layer using TDM scheme may be transmitted.

30 [00595] In this case, an injection level which is larger than the operation SNR of the core layer may be required for decoding of the core layer, and an injection level from about 10 dB to 25 dB may be required in order that the enhanced layer and the core layer have the same coverage.

Table 7

	Data rate	ModCod	SNR after LDM (injection level = 4dB)	SNR after LDM (injection level = 1dB)
Core Layer	2.7 Mbps	QPSK & 4/15	-0.5 dB	1.9 dB
Enhanced Layer	24.4 Mbps	256QAM & 9/15	21.0 dB	19.1 dB

5 [00596] Table 7 is a table showing an example of servicing a high data rate 4K-UHD with an enhanced layer in an LDM based service.

[00597] When a data rate of about 25 Mbps is required in an enhanced layer, if an injection level of about 4 dB is applied, an SNR of more than 20 dB is required to the enhanced layer.

10 [00598] Accordingly, if the LDM injection level can be 0 dB ~ 3 dB, even if such a high data rate service is applied, the SNR required for the enhanced layer can be the less than 20 dB for the service.

[00599] FIG. 33 is a graph showing a scaling factor according to the change of the LDM injection level value (dB).

15 [00600] Referring to FIG. 33, it can be seen that the scaling factor changes rapidly in the section of 0 dB ~ 5 dB and changes relatively gradually in the section of 5 dB ~ 25 dB. In this case, the scaling factor may represent the linear scale value of the enhanced layer signal to be inserted.

20 [00601] Accordingly, more fine step size (0.5 dB) in the section from 0 dB to 5 dB may be required and less fine step size (1 dB) in the section from 5 dB to 25 dB may be required.

Table 8

Value	Injection level [dB]
00000	0.0
00001	0.5
00010	1.0
00011	1.5
00100	2.0
00101	2.5
00110	3.0
00111	3.5
01000	4.0
01001	4.5
01010	5.0
01011	6.0
01100	7.0
01101	8.0
01110	9.0

01111	10.0
10000	11.0
10001	12.0
10010	13.0
10011	14.0
10100	15.0
10101	16.0
10110	17.0
10111	18.0
11000	19.0
11001	20.0
11010	21.0
11011	22.0
11100	23.0
11101	24.0
11110	25.0
11111	Reserved

[00602] Table 8 is a table showing an example of the correspondence relationship between the 5 bit-field values and the injection level information.

[00603] The example of Table 8 includes 5 bit-field values corresponding to less than 3.0 dB injection level information (0.0 dB, 0.5 dB, 1.0 dB, 1.5 dB, 2.0 dB, 2.5dB) and includes greater than 10 dB injection level information (11 dB, 12 dB, 13 dB, 14 dB, 15 dB, 16 dB, 17 dB, 18 dB, 19 dB, 20 dB, 21 dB, 22 dB, 23 dB, 24 dB, 25 dB). In this case, less than 3.0 dB injection level information may be for coverage extension of the enhanced layer service as described with reference to Table 7 above. In this case, greater than 10 dB injection level information may be for LDM based local service implementation as described with reference to Tables 5 and 6, FIGS. 31 and 32 above.

[00604] Furthermore, it can be seen that it is changed by 0.5 dB step size unit in the section from 0.0 dB to 5 dB (the first section) and changed by 1.0 dB step size unit in the section from 6 dB (or 5 dB) to 25 dB (the second section) in Table 8. In this way, the correspondence relationship such as Table 8 can appropriately reflect the change of the scaling factor by including two sections having different step sizes.

[00605]

[00606] As described above, the apparatus and method for generating broadcast signal frame according to the present invention are not limited to the configurations and methods of the aforementioned embodiments, but some or all of the embodiments may be selectively combined such that the embodiments are modified in various manners.

CLAIMS

1. An apparatus for generating broadcast signal frame, comprising:
 - an injection level controller configured to generate a power reduced enhanced layer signal by reducing a power of an enhanced layer signal;
 - 5 a combiner configured to generate a multiplexed signal by combining a core layer signal and the power reduced enhanced layer signal;
 - a power normalizer configured to reduce power of the multiplexed signal to a power level corresponding to the core layer signal;
 - a time interleaver configured to generate a time-interleaved signal by performing interleaving that is applied to both the core layer signal and the enhanced layer signal; and
 - 10 a frame builder configured to generate a broadcast signal frame including a preamble for signaling injection level information corresponding to the injection level controller.
- 15 2. The apparatus of claim 1, wherein the injection level information is signaled by using 31 values which are identified using a 5 bit-field.
3. The apparatus of claim 2, wherein the power normalizer corresponds to a normalizing factor which increases as a power reduction corresponding to the injection level controller becomes larger and the injection level controller corresponds to a scaling factor which decreases as the power reduction corresponding to the injection level controller becomes larger.
- 20 4. The apparatus of claim 3, wherein the 31 values are matched with 5 bit field values belonging to any one of a first section corresponding to a first step size and a second section corresponding to a second step size, the second step size being different from the first step size.
- 25 5. The apparatus of claim 4, wherein the first section corresponds to a first rate of change of the scaling factor and the second section corresponds to a second rate of change of the scaling factor, the second rate of change being less than the first rate of change .
- 30 6. The apparatus of claim 4, wherein the first section corresponds to a section from 0 dB to 5 dB and the second section corresponds to a section from 6
- 35

dB to 25 dB.

7. The apparatus of claim 6, wherein the first step size is 0.5 dB and the second step size is 1 dB.

5

8. The apparatus of claim 7, wherein the first section includes 5 bit-field values belonging to a section of 0 dB (inclusive) ~ 3 dB (exclusive) and the second section includes 5 bit-field values belonging to a section of 10 dB (exclusive) ~ 25 dB (inclusive).

10

9. The apparatus of claim 8, wherein the preamble includes layer identification information for identifying layers corresponding to a hierarchical division.

15

10. The apparatus of claim 9, wherein the preamble selectively includes the injection level information according to a result of comparing the layer identification information with a predetermined value for each of Physical Layer Pipes (PLPs).

20

11. A method of generating broadcast signal frame, comprising:
generating a power reduced enhanced layer signal by reducing a power of an enhanced layer signal;
generating a multiplexed signal by combining a core layer signal and the power reduced enhanced layer signal;
reducing power of the multiplexed signal to a power level corresponding to the core layer signal;
generating a time-interleaved signal by performing interleaving that is applied to both the core layer signal and the enhanced layer signal; and
generating a broadcast signal frame including a preamble for signaling injection level information corresponding to the power reduced enhanced layer signal.

25

30

12. The method of claim 11, wherein the injection level information is signaled by using 31 values which are identified using a 5 bit-field.

35

13. The method of claim 12, wherein the reducing power of the multiplexed signal corresponds to a normalizing factor which increases as a

power reduction corresponding to the power reduced enhanced layer signal becomes larger, and

the generating the power reduced enhanced layer signal corresponds to a scaling factor which decreases as the power reduction corresponding to the power reduced enhanced layer signal becomes larger.

14. The method of claim 13, wherein the 31 values are matched with 5 bit field values belonging to any one of a first section corresponding to a first step size and a second section corresponding to a second step size, the second step size being different from the first step size.

15. The method of claim 14, wherein the first section corresponds to a first rate of change of the scaling factor and the second section corresponds to a second rate of change of the scaling factor, the second rate of change being less than the first rate of change.

16. The method of claim 14, wherein the first section corresponds to a section from 0 dB to 5 dB and the second section corresponds to a section from 6 dB to 25 dB.

17. The method of claim 16, wherein the first step size is 0.5 dB and the second step size is 1 dB.

18. The method of claim 17, wherein the first section includes 5 bit-field values belonging to a section of 0 dB (inclusive) ~ 3 dB (exclusive) and the second section includes 5 bit-field values belonging to a section of 10 dB (exclusive) ~ 25 dB (inclusive).

19. The method of claim 18, wherein the preamble includes layer identification information for identifying layers corresponding to a hierarchical division.

20. The method of claim 19, wherein the preamble selectively includes the injection level information according to a result of comparing the layer identification information with a predetermined value for each of Physical Layer Pipes (PLPs).

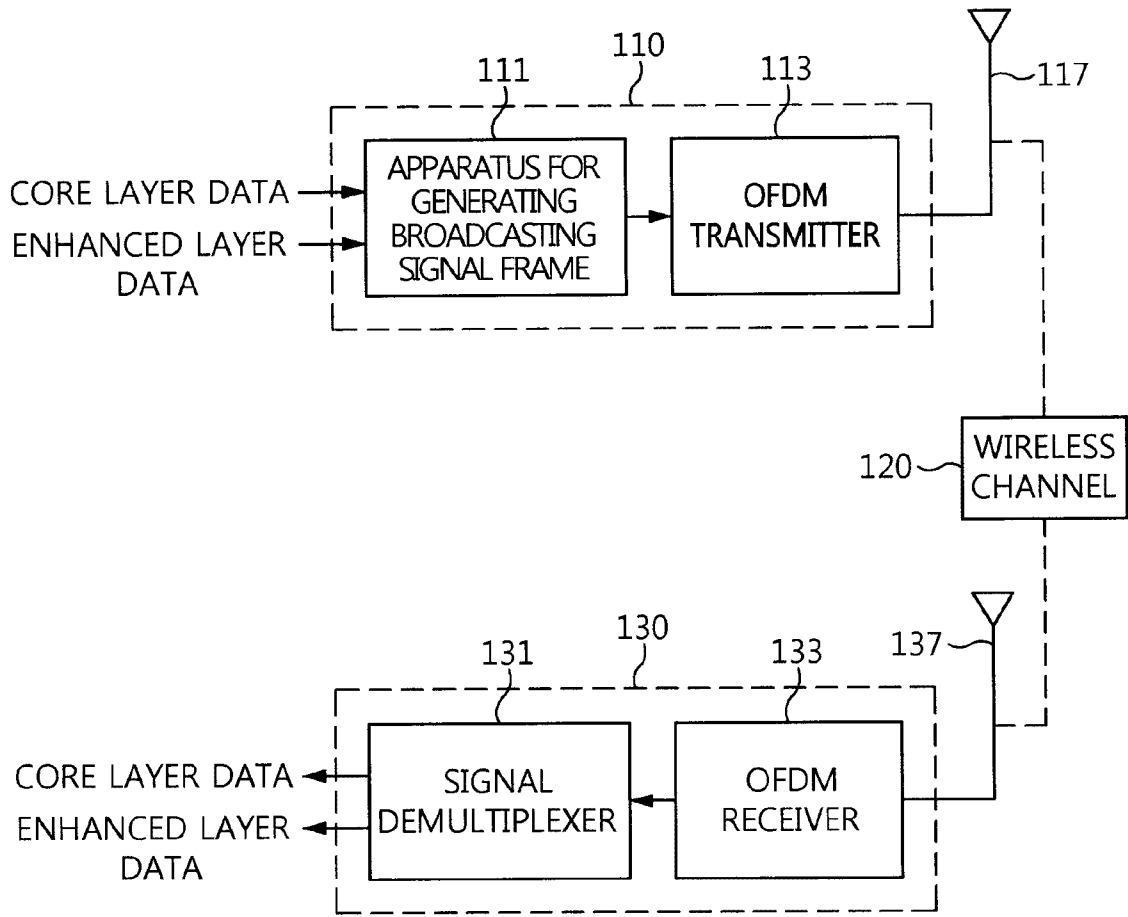

FIG. 1

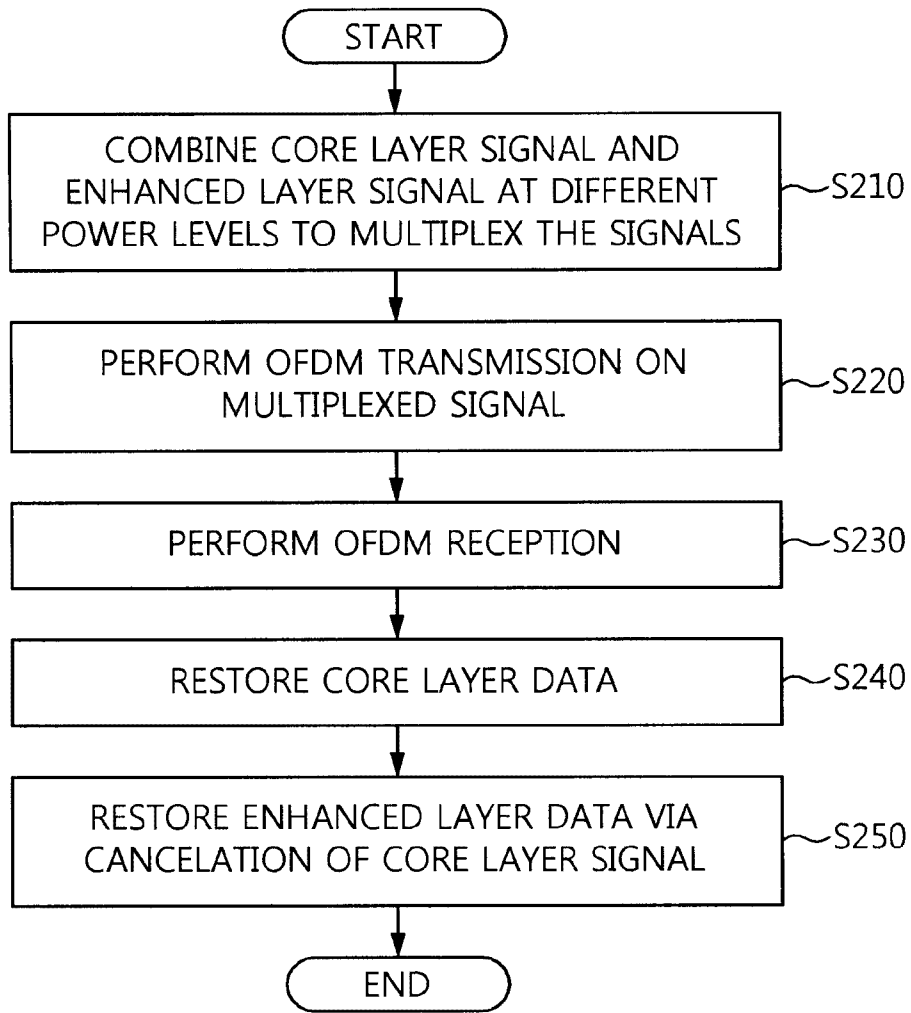

FIG. 2

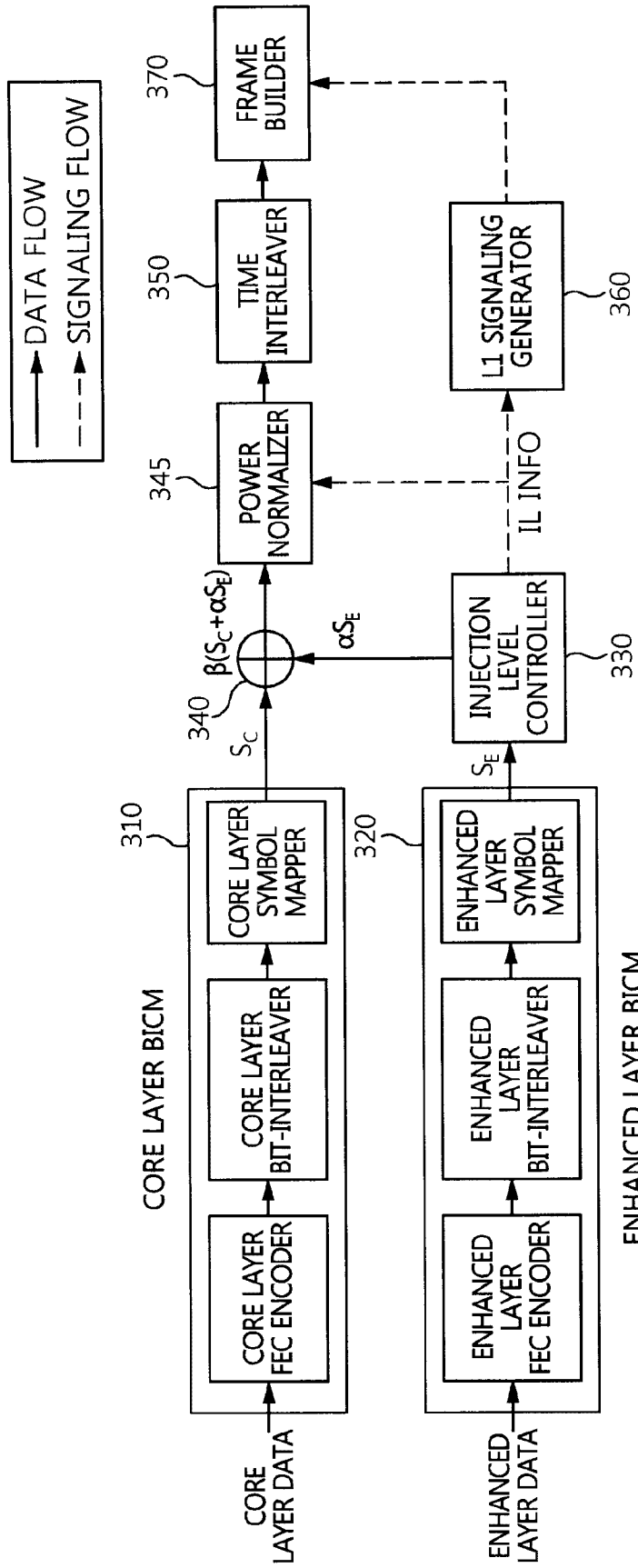

FIG. 3

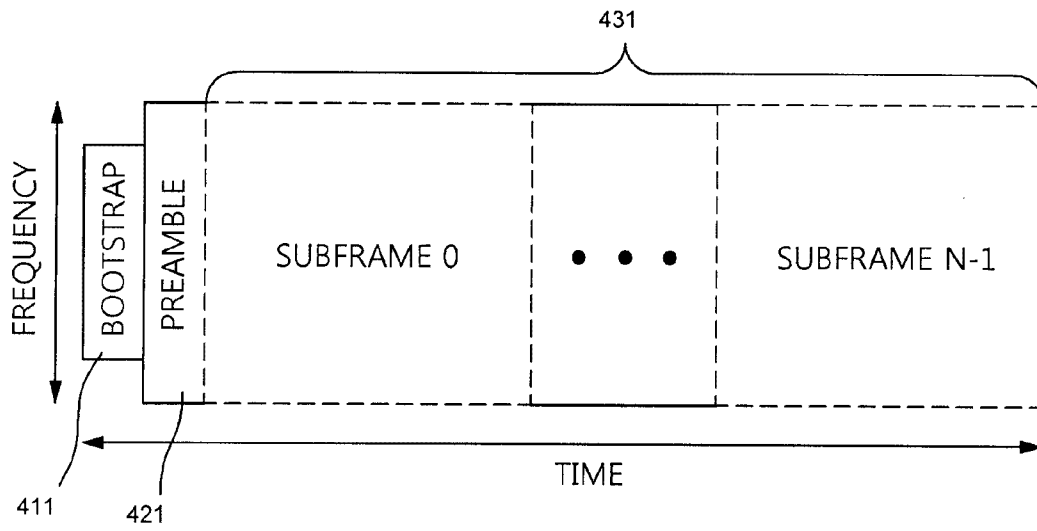

FIG. 4

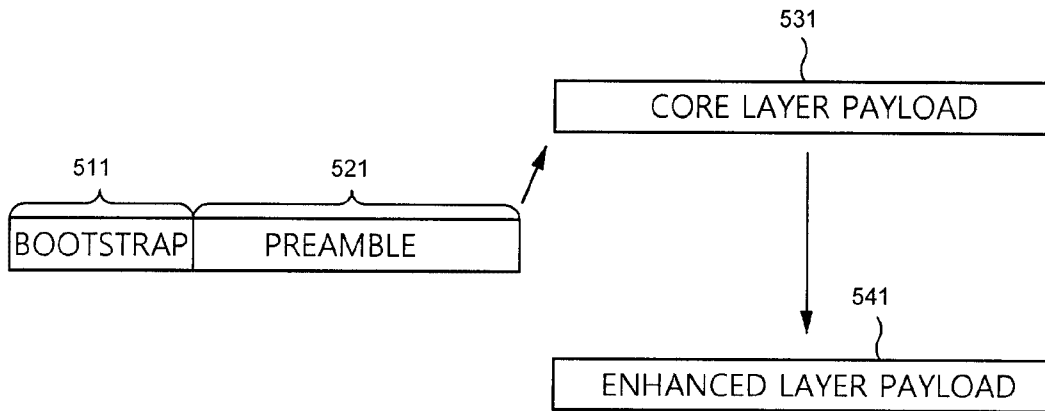

FIG. 5

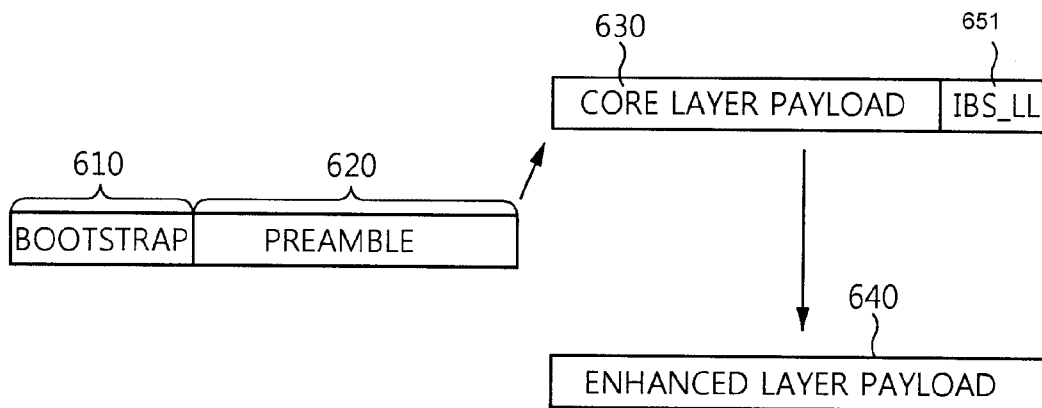

FIG. 6

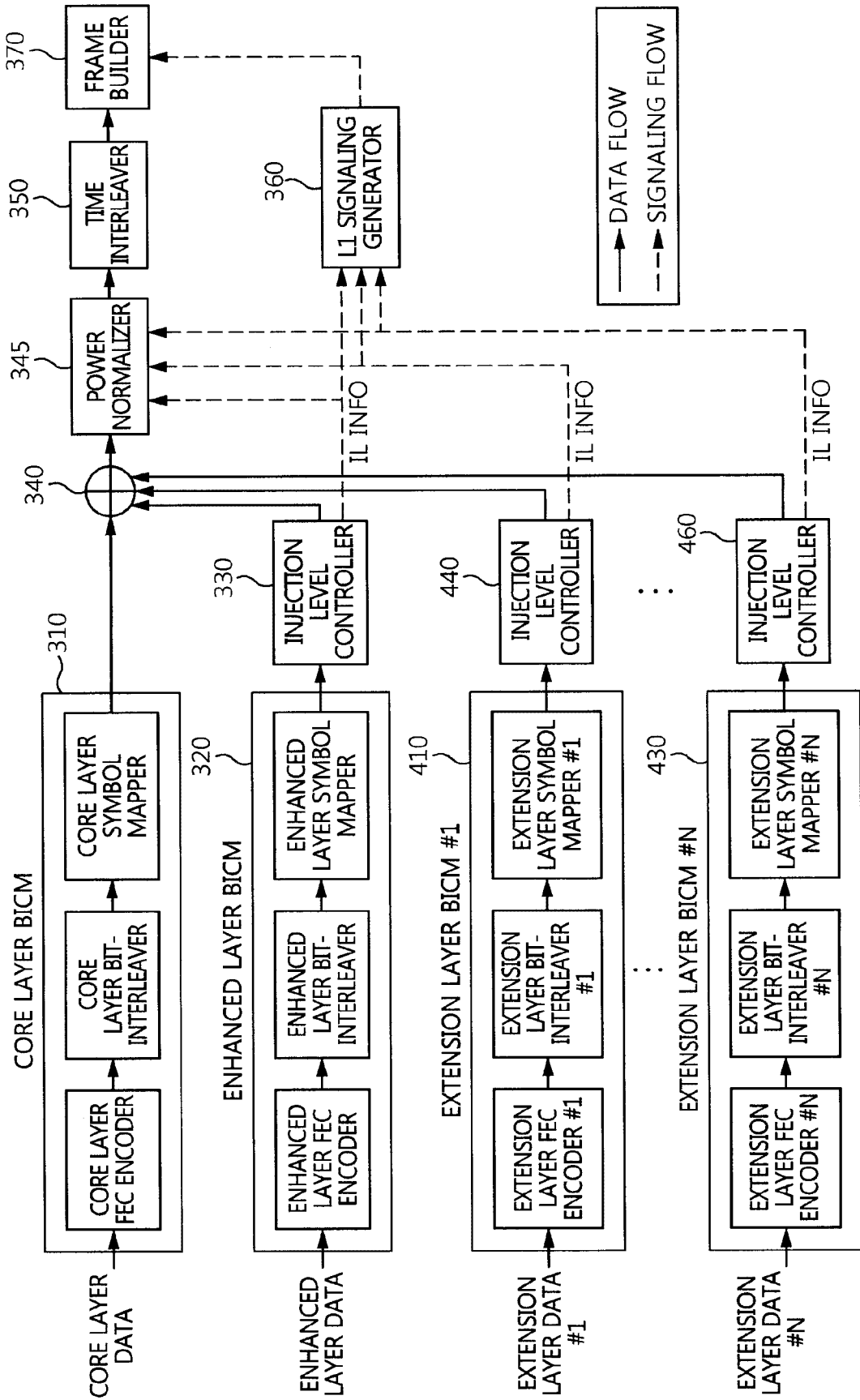

FIG. 7

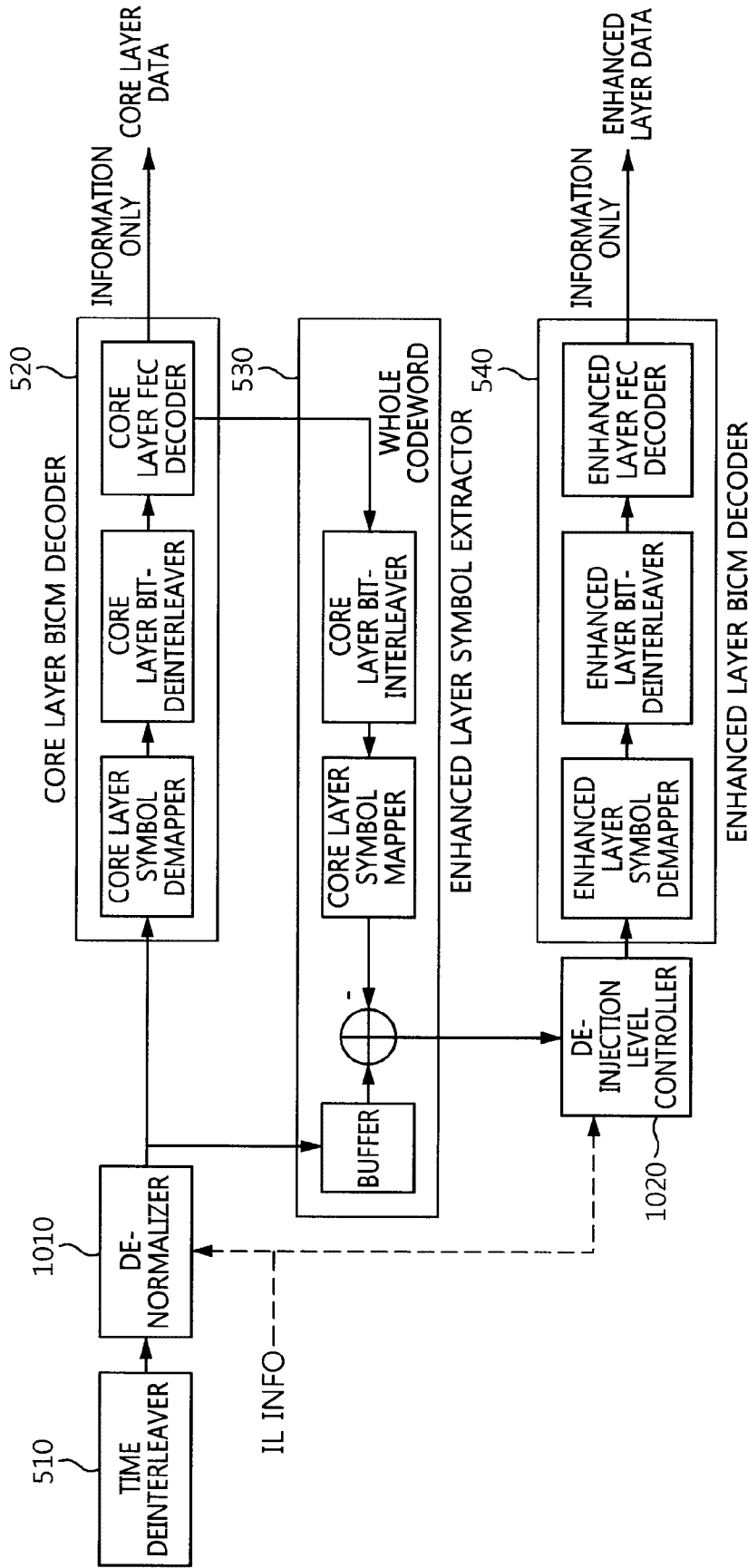

FIG. 8

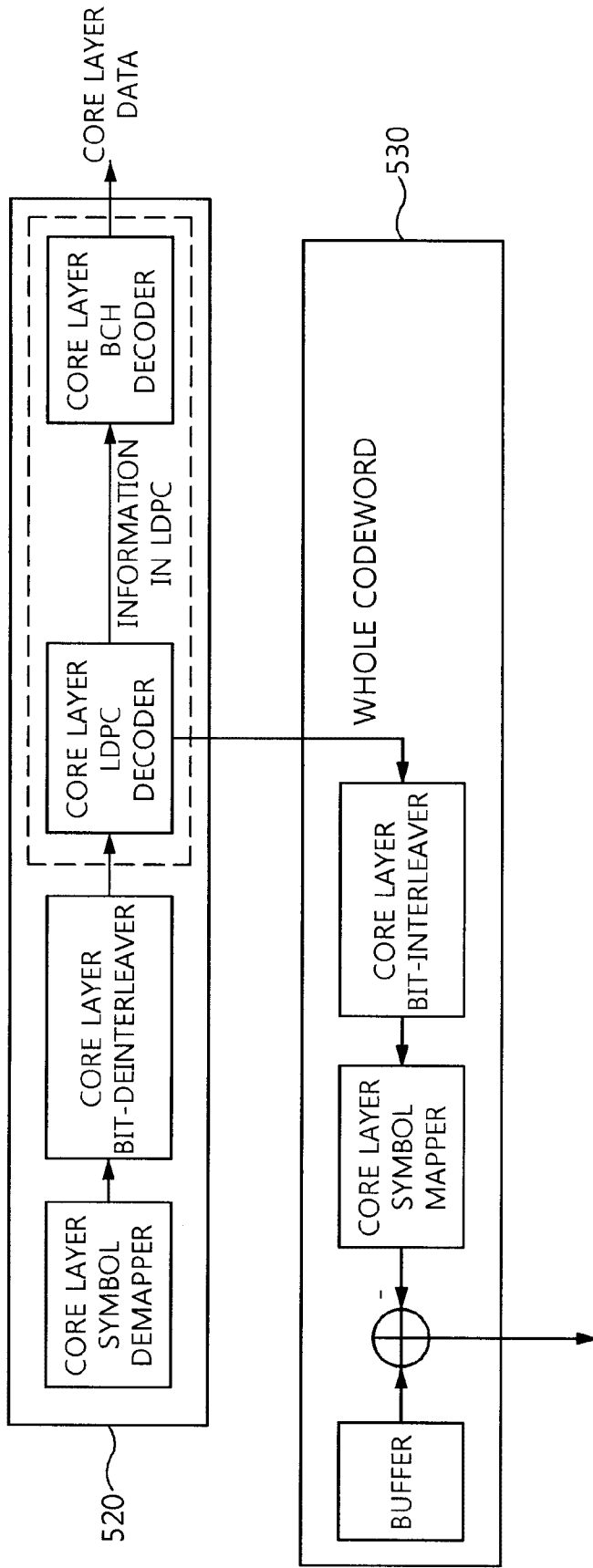

FIG. 9

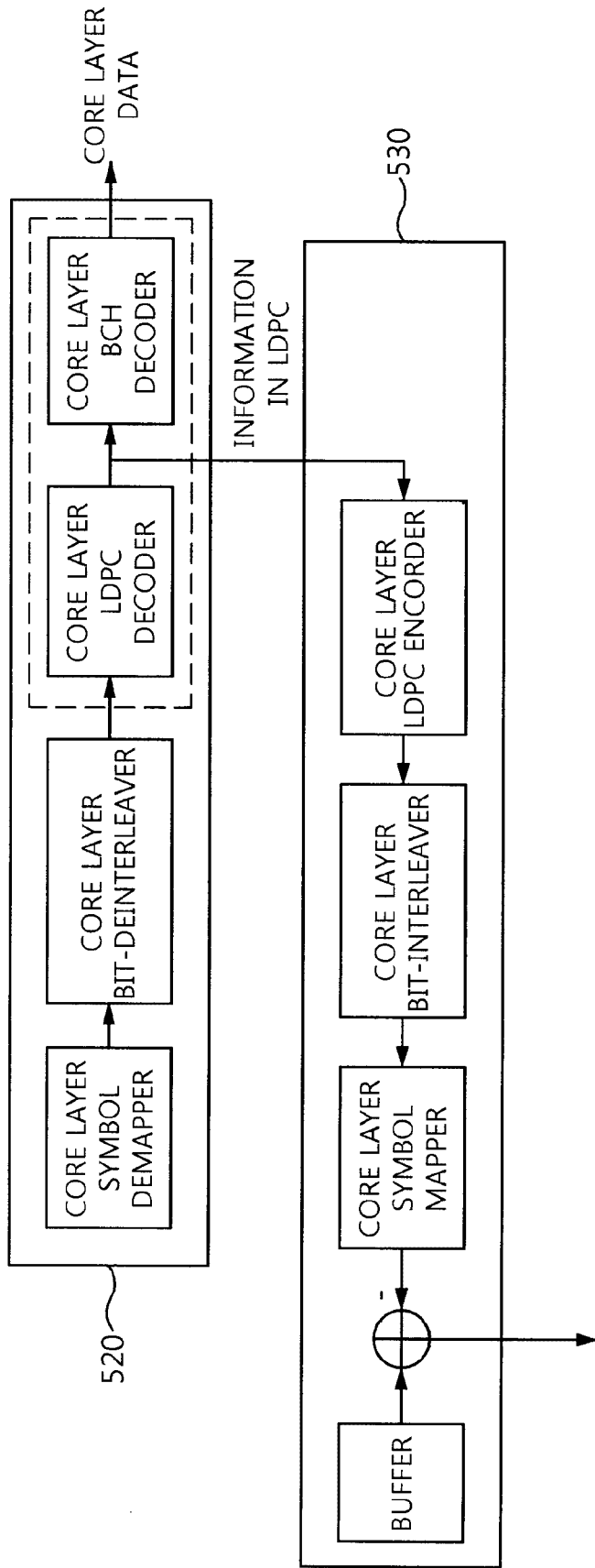

FIG. 10

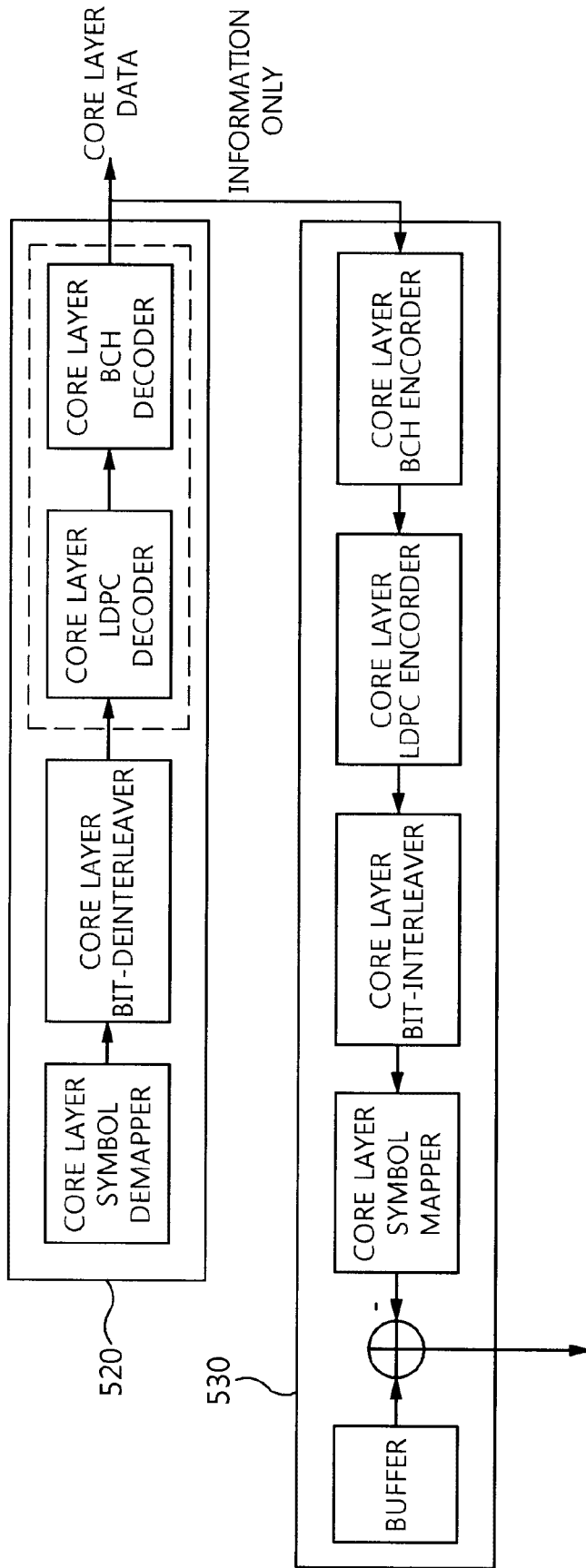

FIG. 11

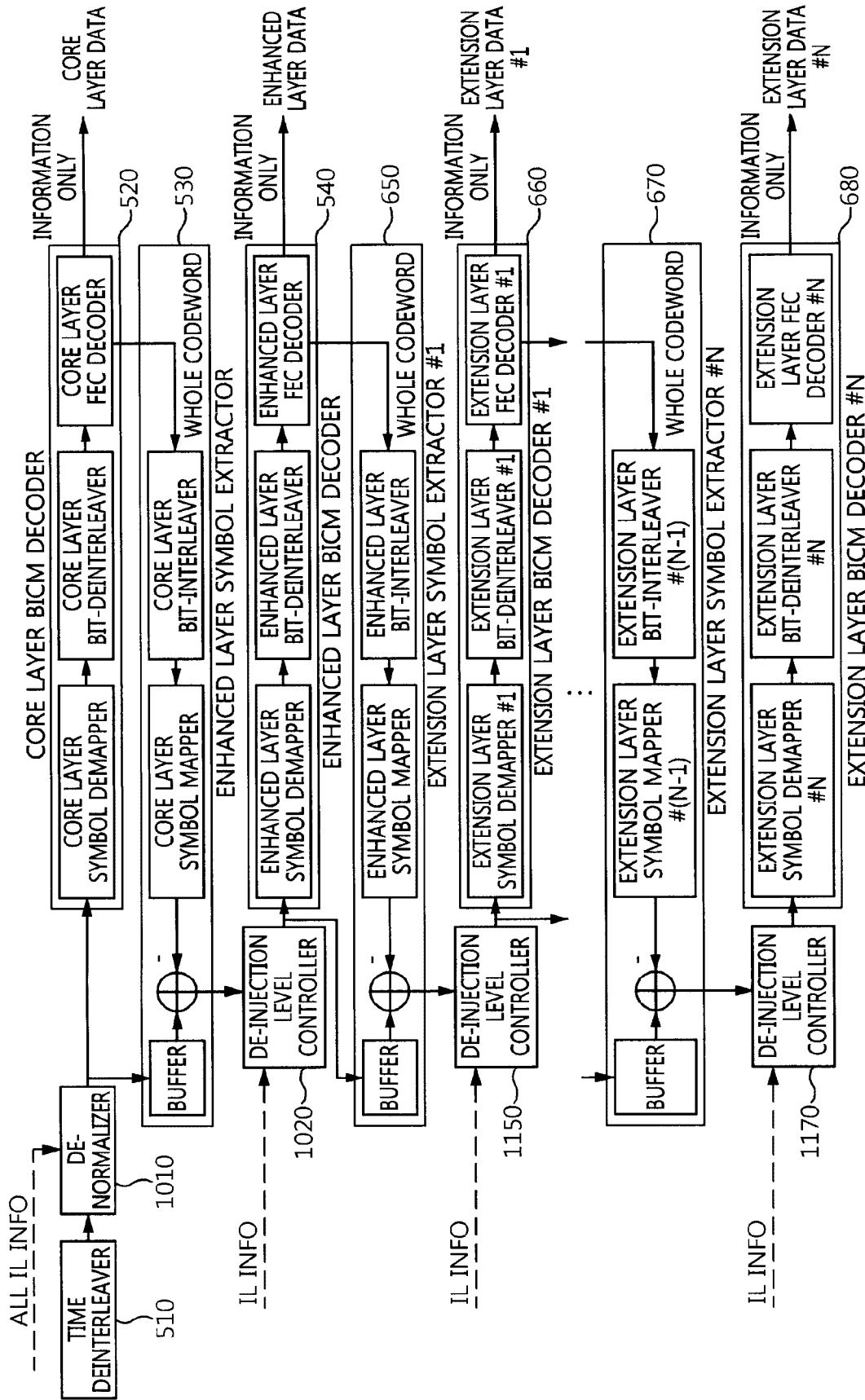

FIG. 12

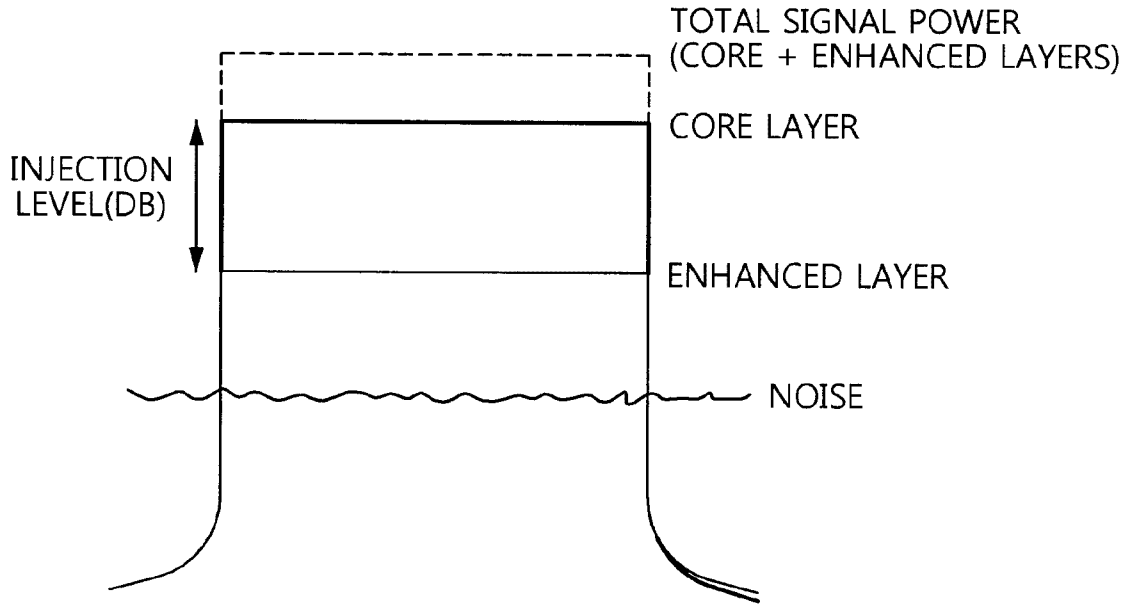

FIG. 13

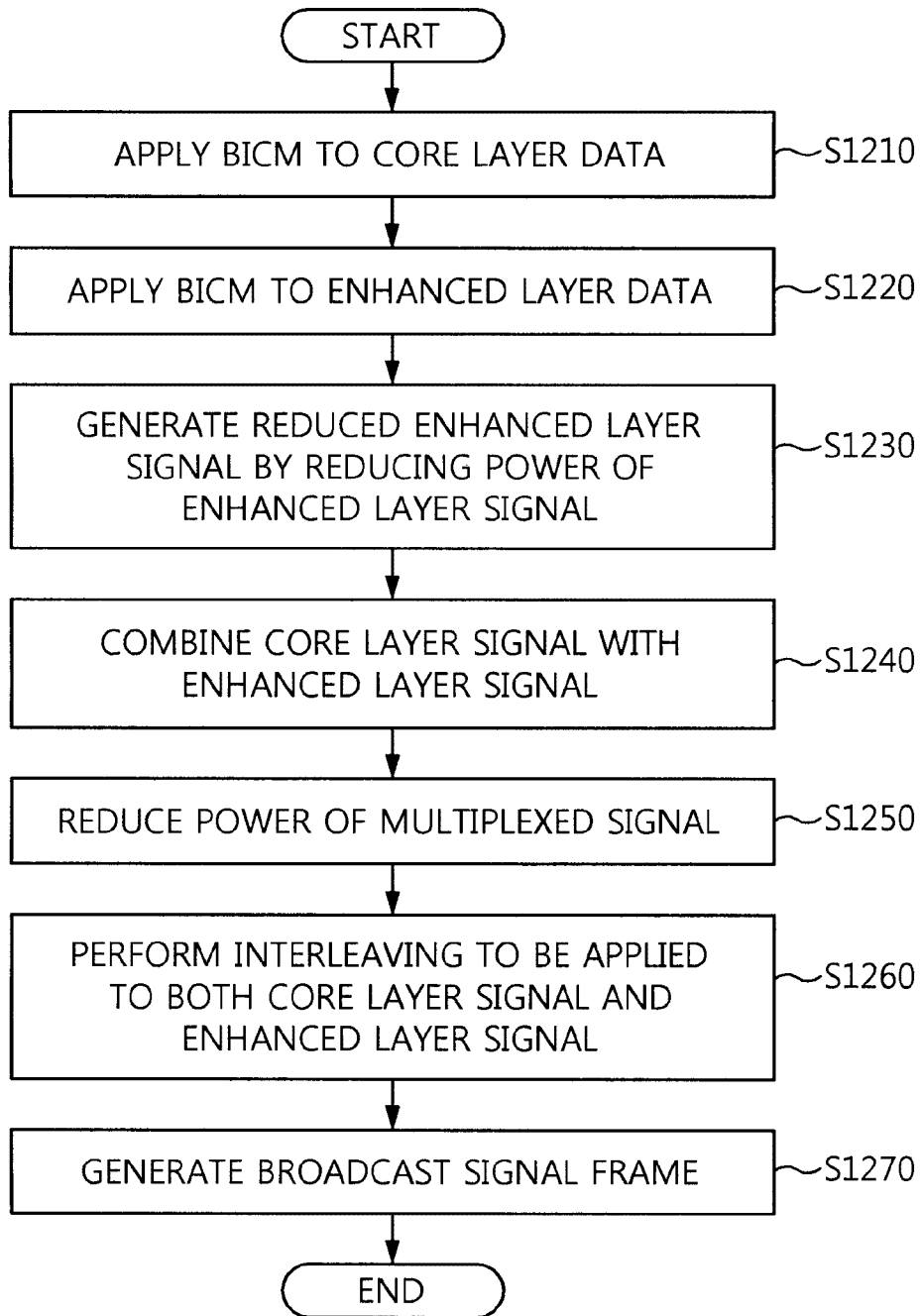

FIG. 14

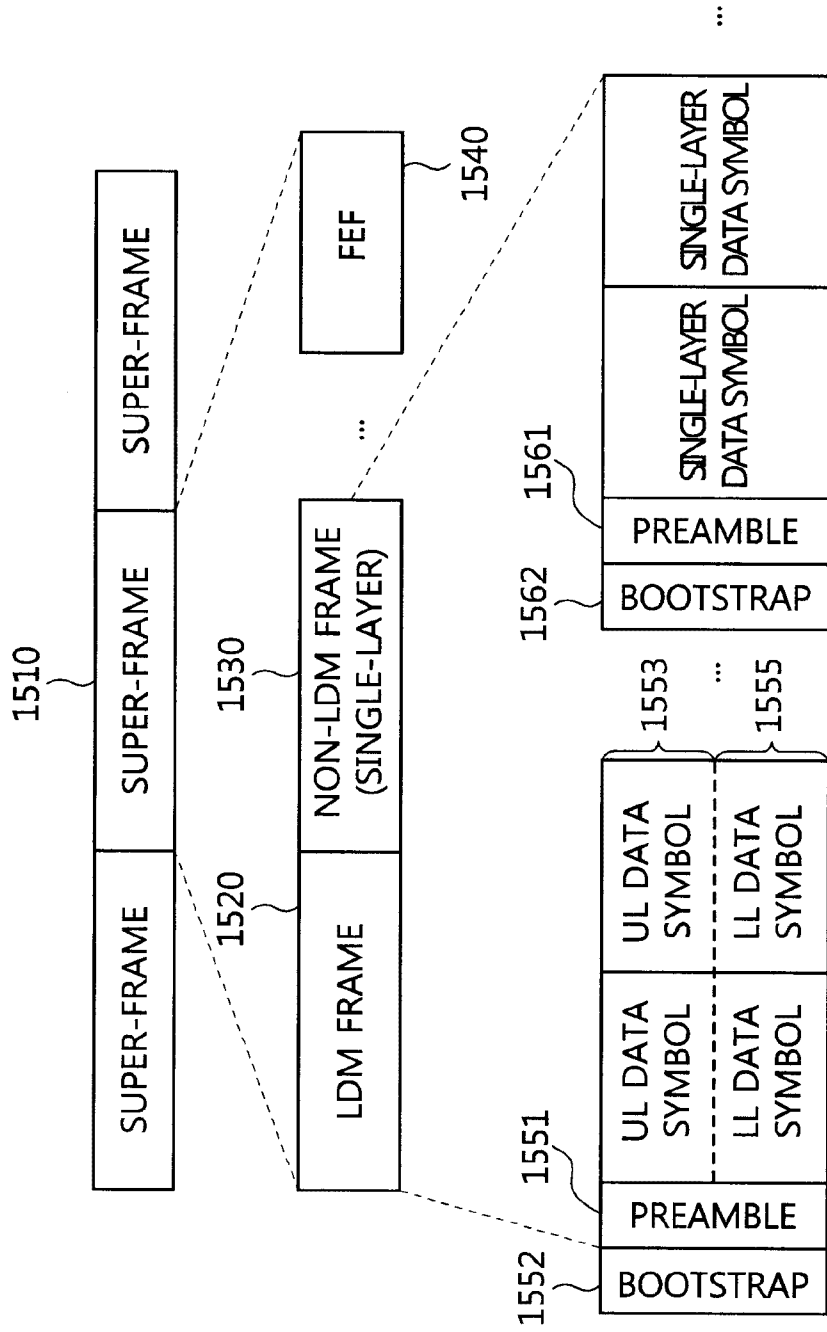

FIG. 15

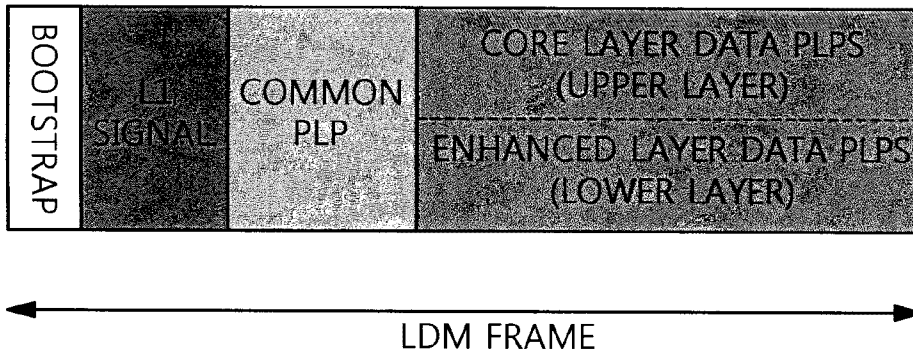

FIG. 16

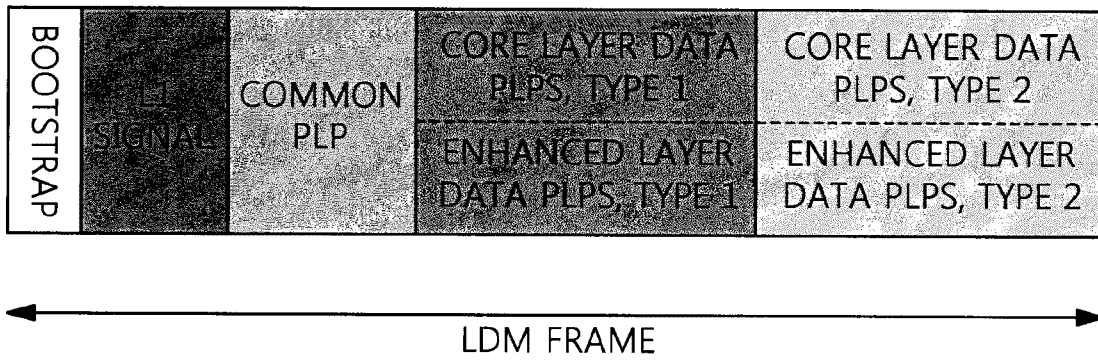

FIG. 17

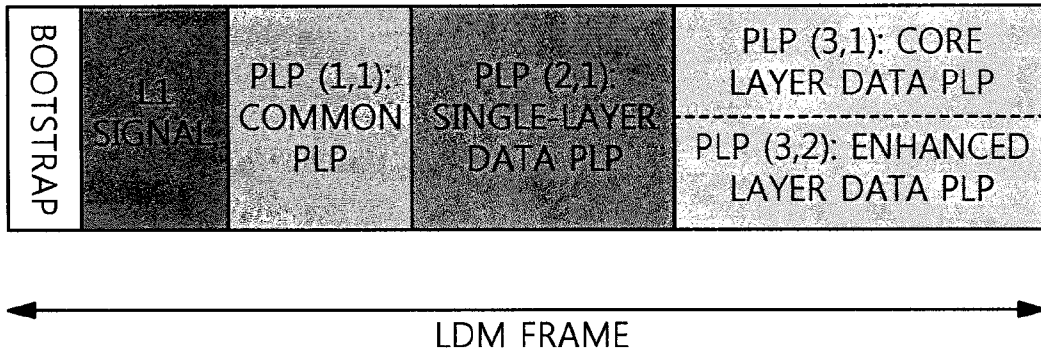

FIG. 18

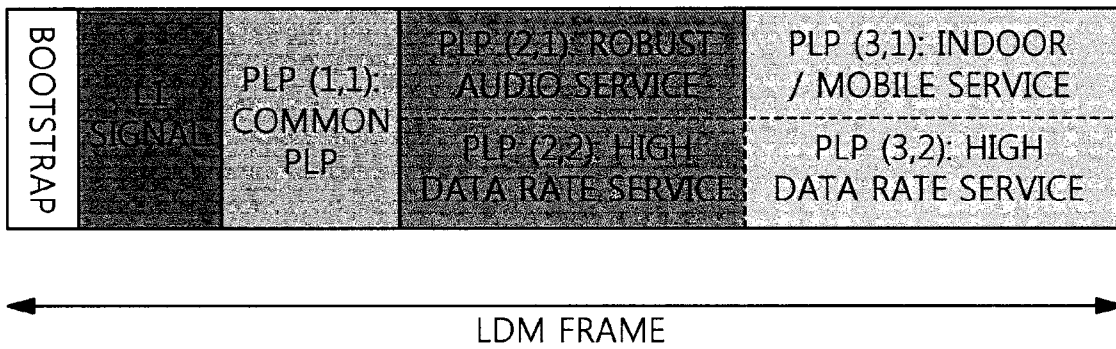

FIG. 19

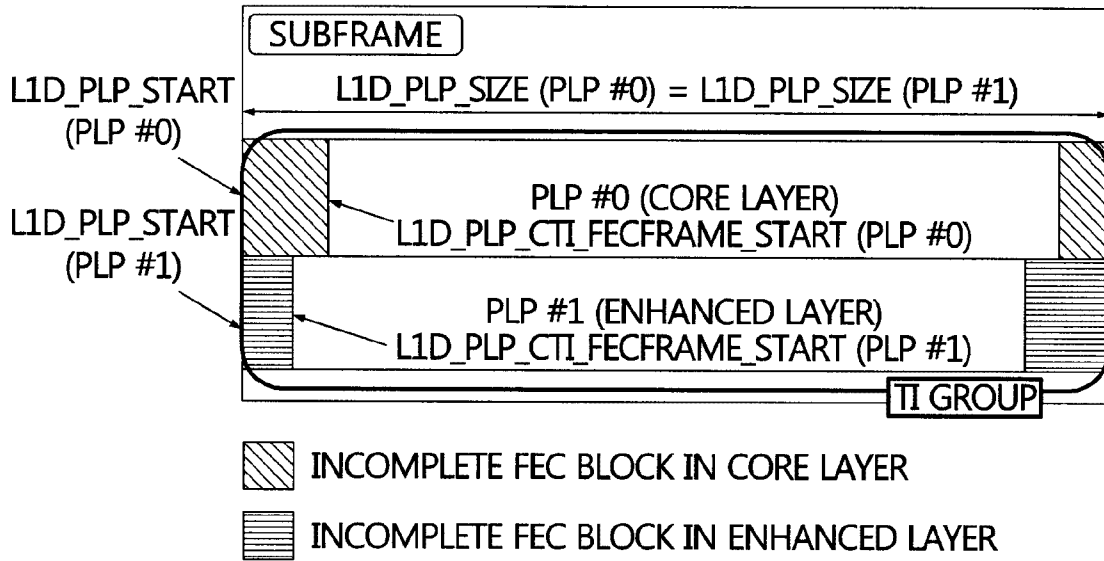

FIG. 20

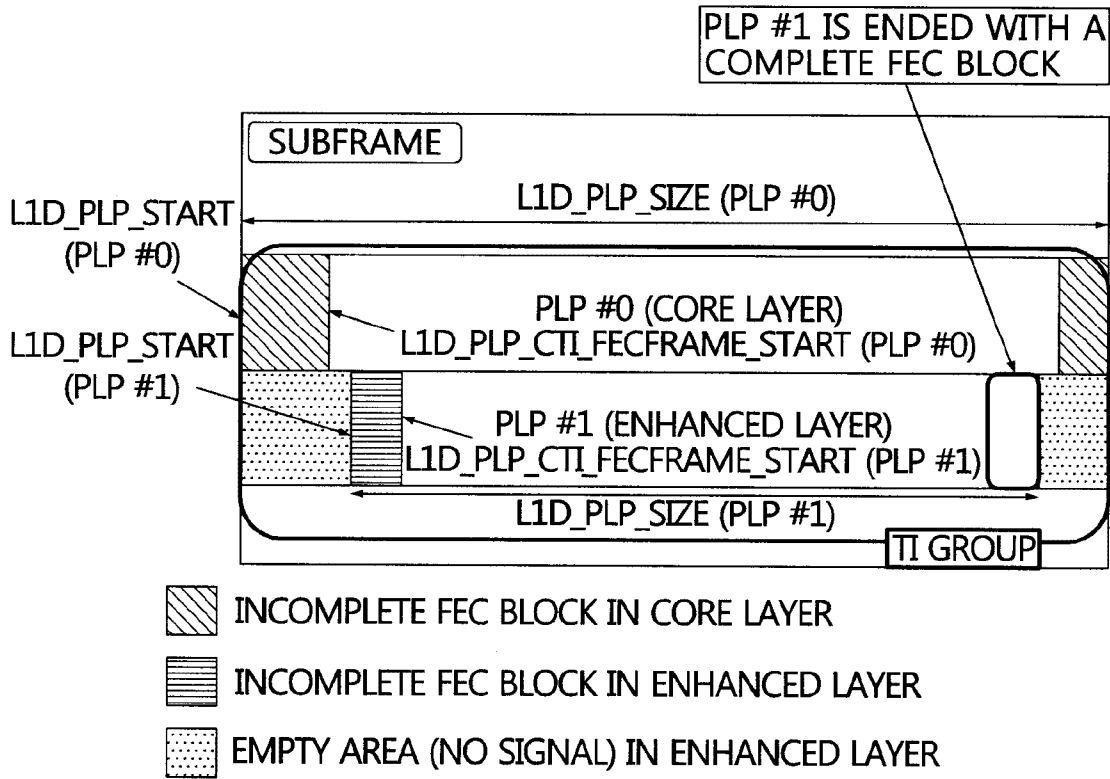

FIG. 21

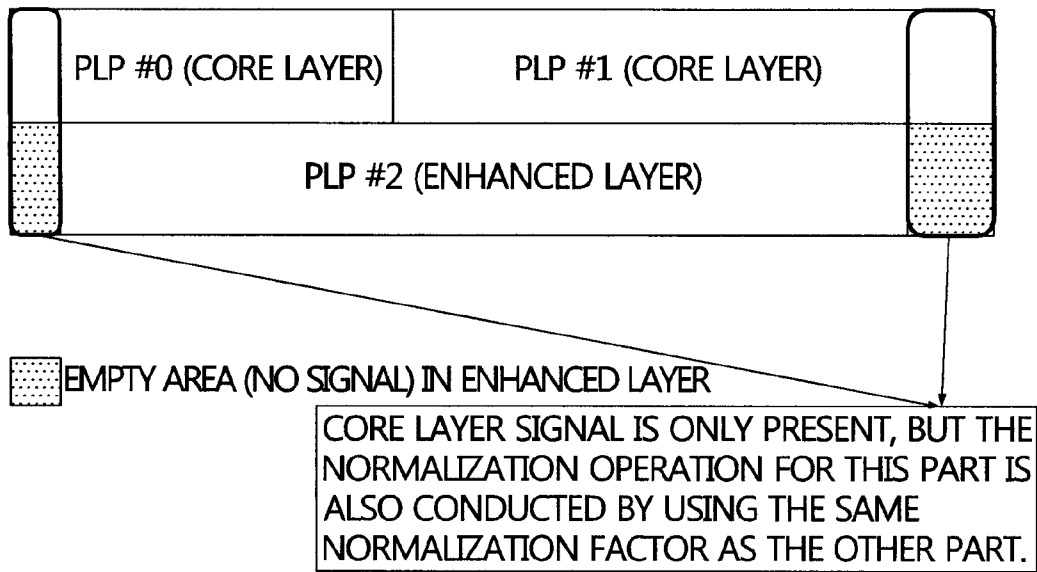

FIG. 22

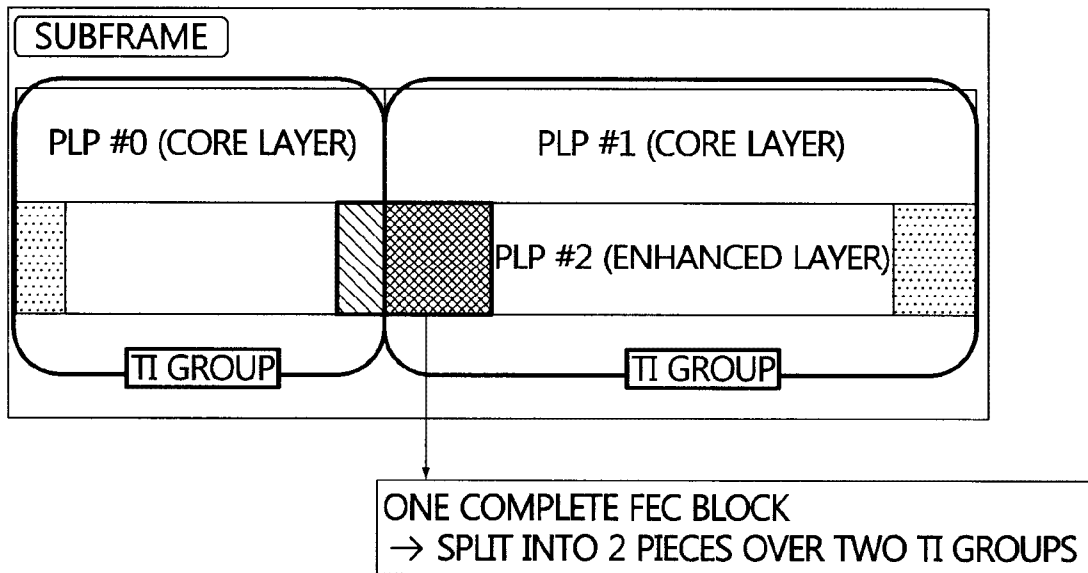

FIG. 23

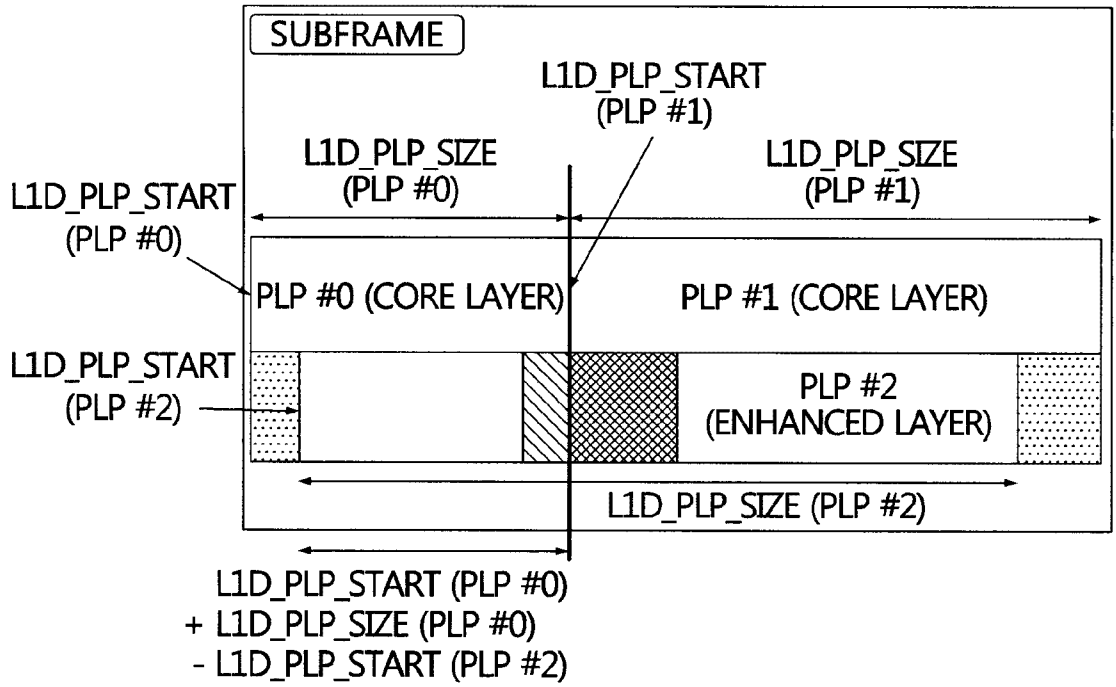
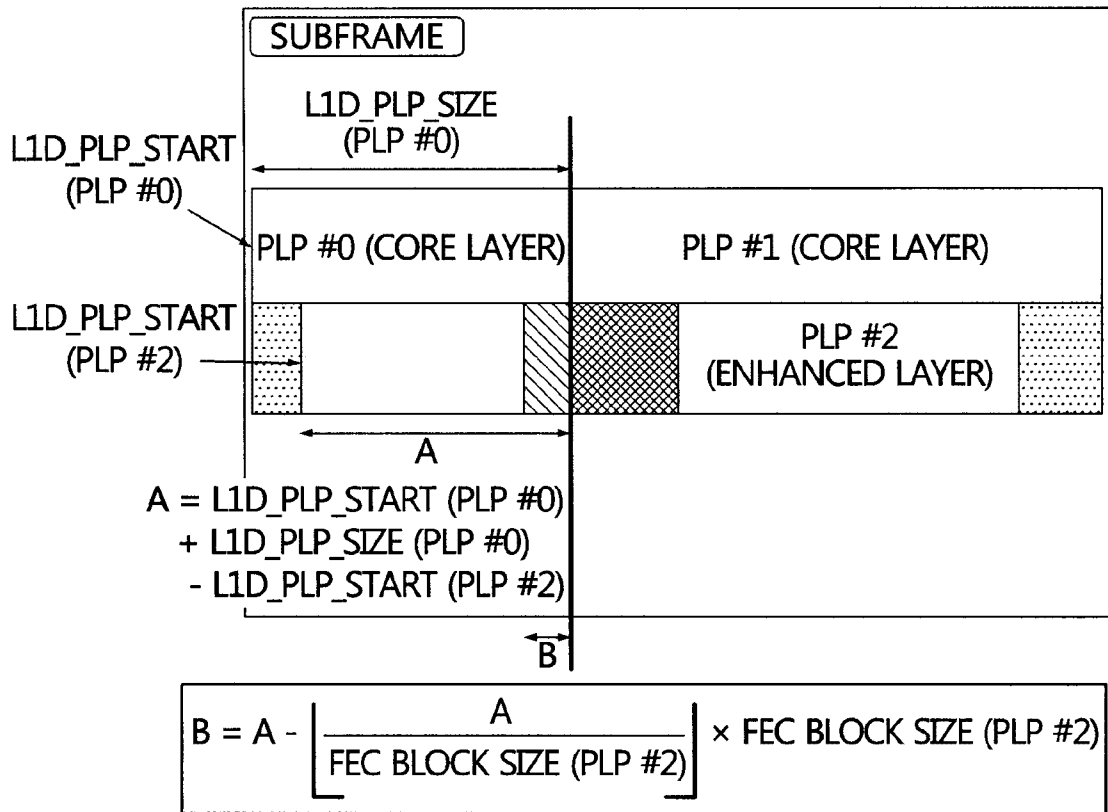

FIG. 24



※ FEC BLOCK SIZE IS DECIDED BY L1D_PLP_MOD
EX.) QPSK : 32400, 16-NUC : 16200, ETC.

FIG. 25

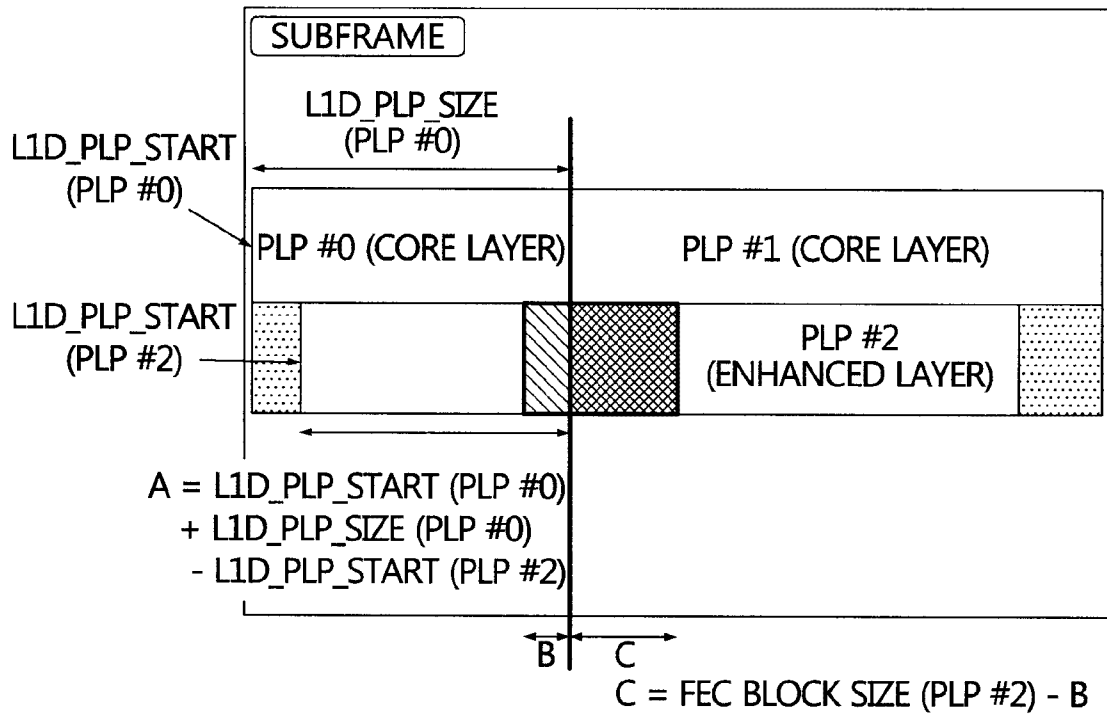

FIG. 26

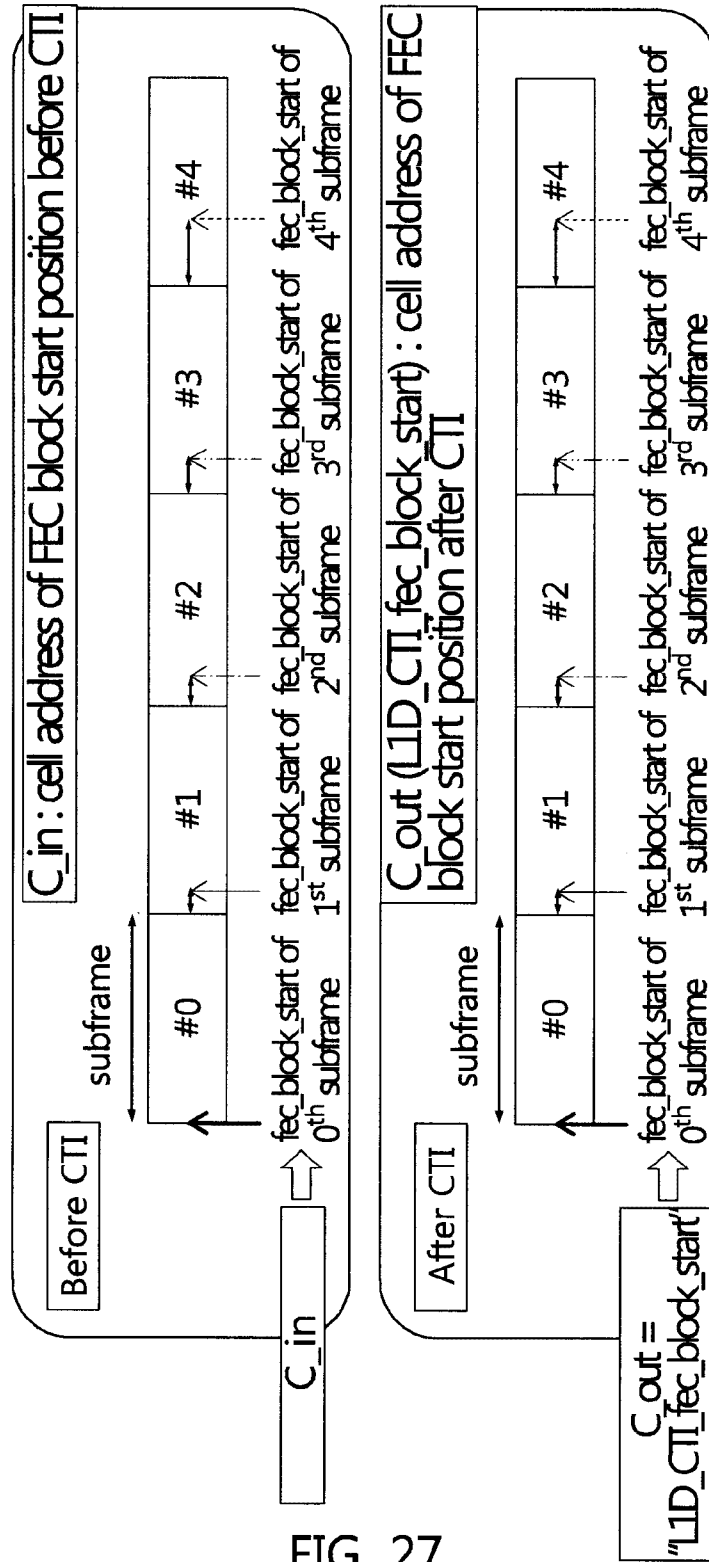

FIG. 27

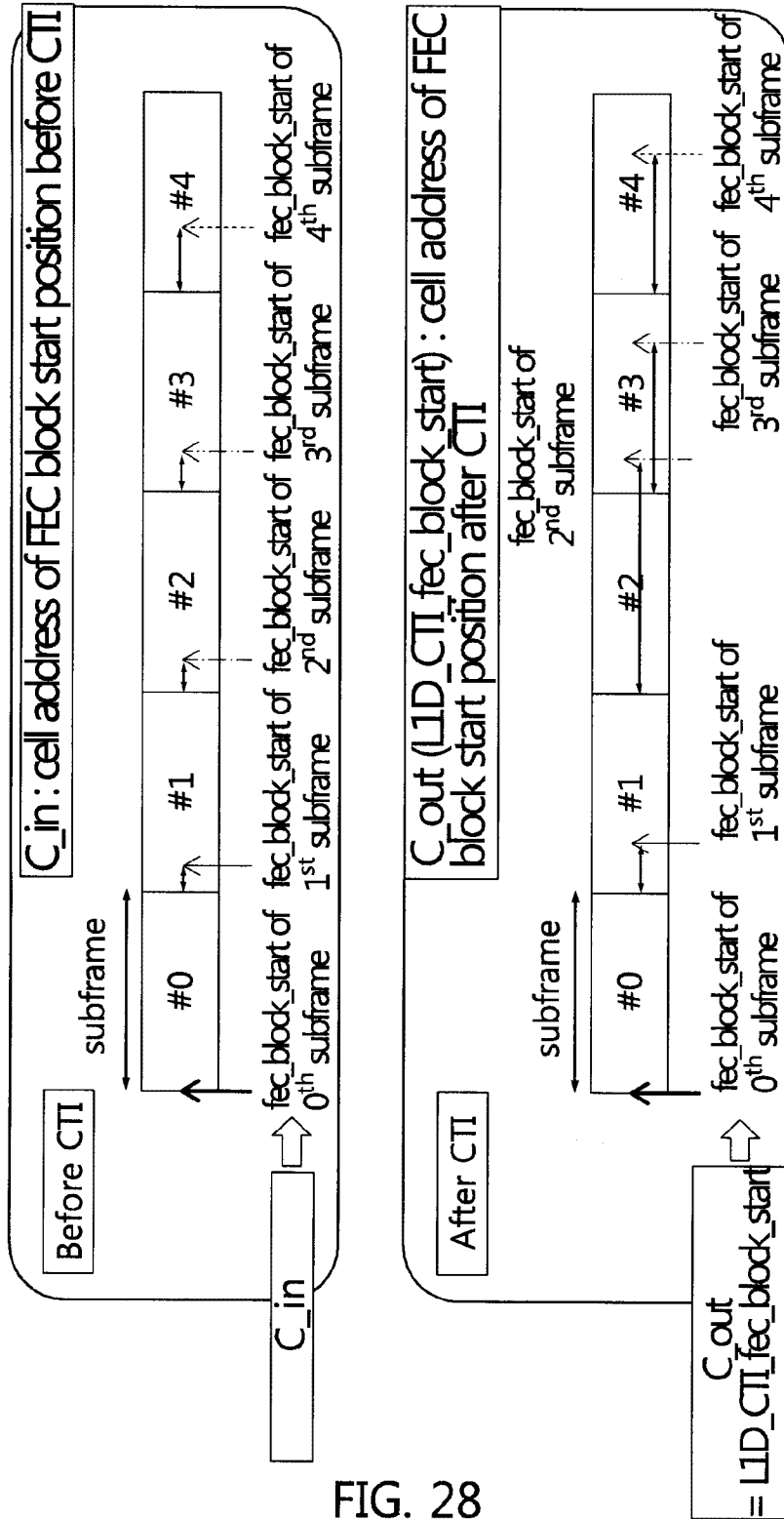

FIG. 28

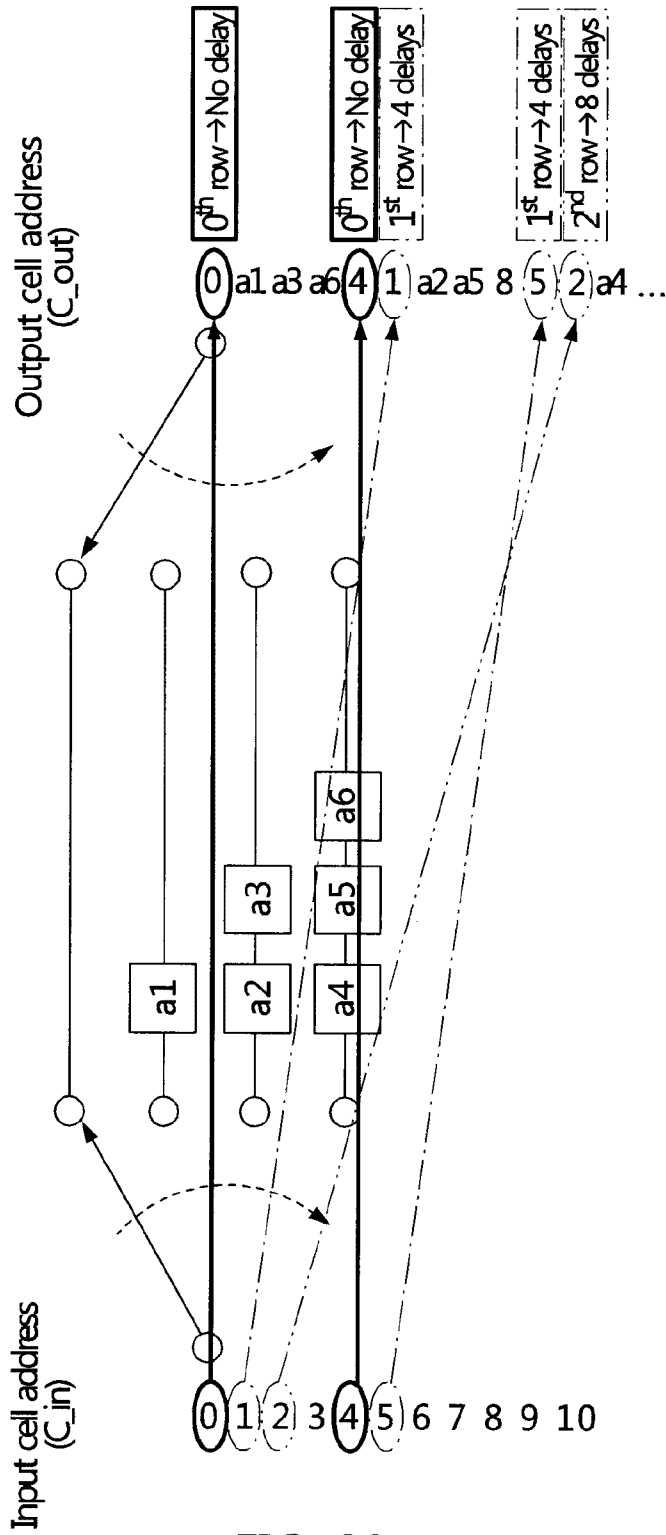

FIG. 29

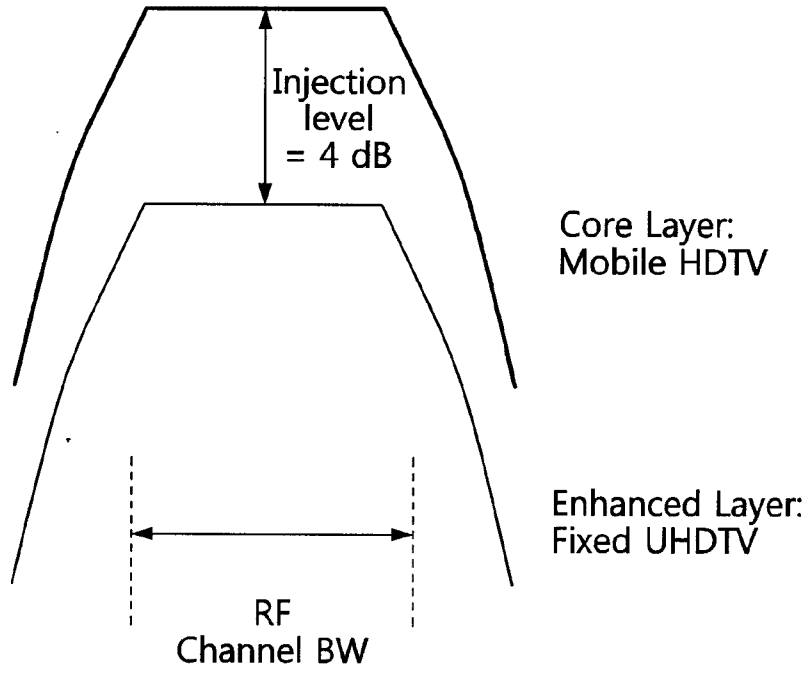

FIG. 30

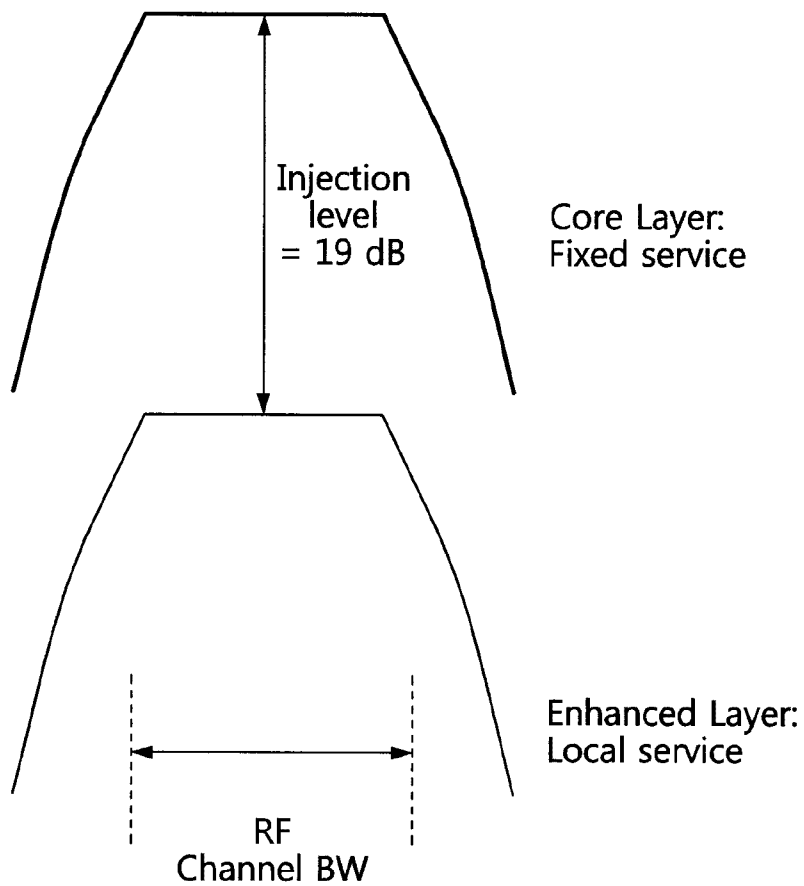

FIG. 31

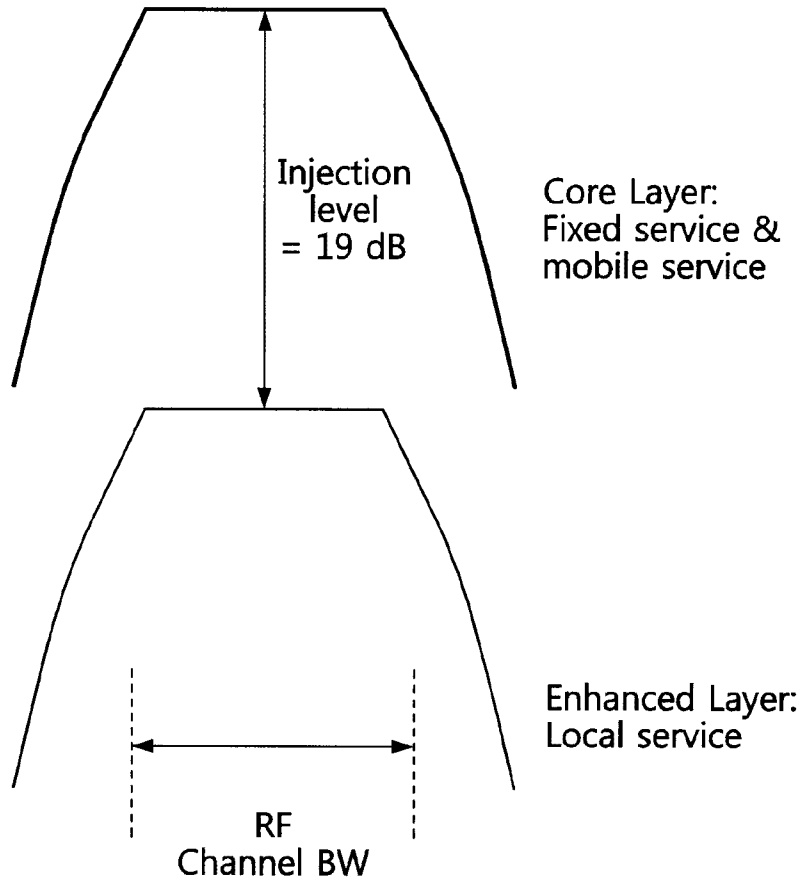

FIG. 32

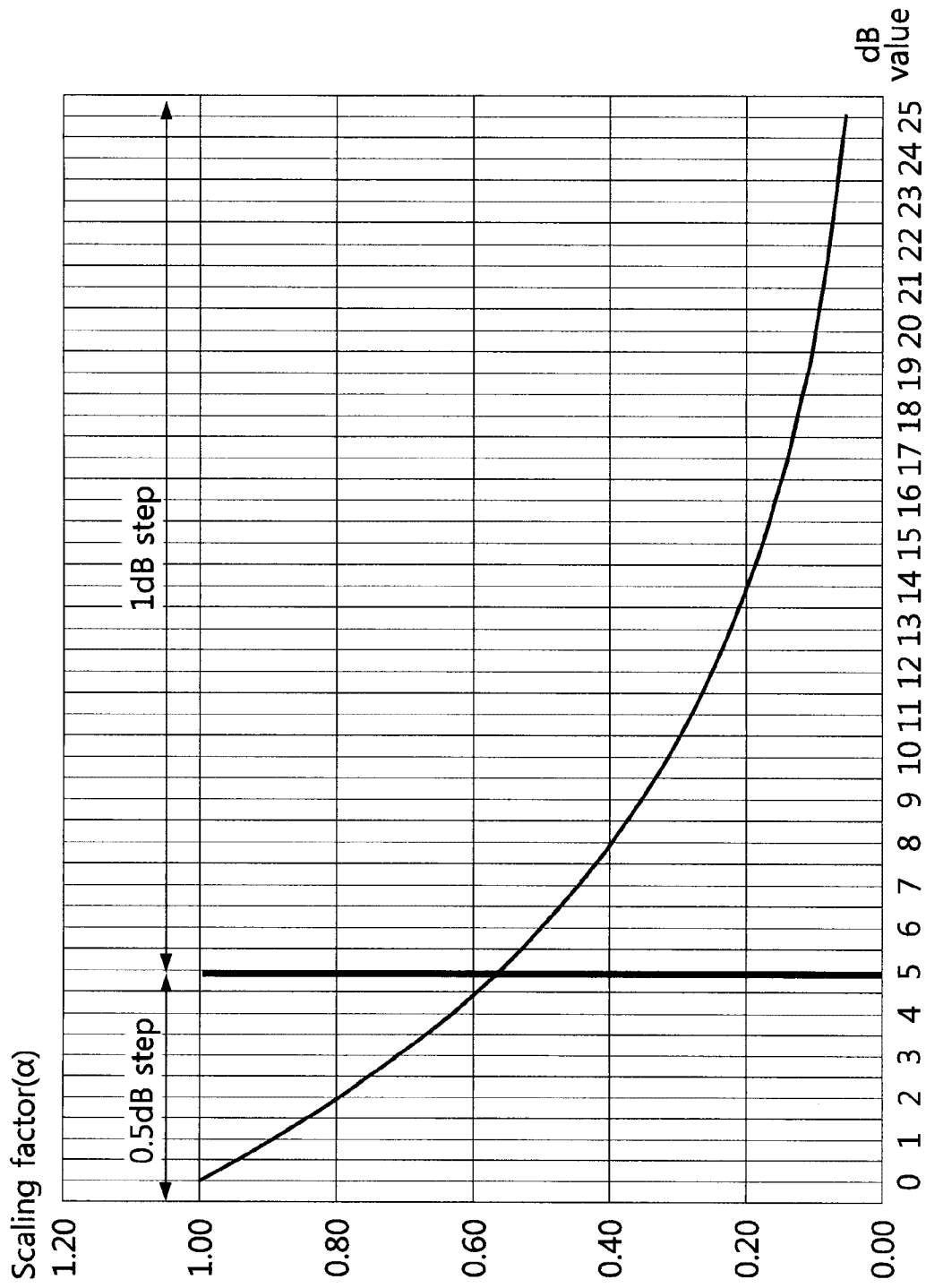

FIG. 33

Scaling factor(α)

