

(19)
(12)

(KR)
(A)

(51) 。 Int. Cl. ⁷
F25B 39/00

(11)
(43)

2002 - 0073044
2002 09 19

(21) 10 - 2001 - 0013201
(22) 2001 03 14

(71) 20

(72) 2 204 905

3 183 - 9618/3

6 105

(74)
:

(54)

가 가 가 가

4

1

2 .

3 .

4 .

5 .

6a 6b

**

**

10 : 11 :

12 : 12a :

12b : 12c :

13 :

,
.
,
,
,
.

, 가

가

1 가

(F) (R) ()

()

(1) (1) 가 (F)

(R) (2)

2

, (end plate)(1a) ,

(1a) (1a) (1b)

(fin plate)(1b) ,

(1a) (1c)

(1c) (1a) () (1b)

(1b) (1a) (1c)

가

(1c)

가 가

(2) (F) (R) (F,R)

(1) 가 가 (2) 가 (F,R)

가 (1) (1b) (1c) (1b) (1c) () ()

(1) 가

가가

가 가

3 4

5

(11) (10) (11) (11)

(12) (13) (12) (11)

(11) (12)

(13) () (12)

cm가 (12) (12a)가 (11) 가 가 5 15

(12a) 가 (12) (12b) 6a
6b (edge point) (12c)

(13) (12) 가 (12)

(1) (F) (1) (R) 가
(10) (F) (R)
(F)(R)

(12a) (T1) 가 (13) 가 (12) 가 (10) (12a)가
(T2) (T3)

b) (13) 4 5 (12) (13) (a)
가 가 가 (T3) 가 가 (b)
(12) (T2)가 (13) 가 가

가 가 (12) (b) (12)
(12a)

가 가 (12) (c) (13) (13)
가 가 (T1) (12a)
(12) (12a) (12b) 가

가 가 ,

(57)

1.

가

2.

1 ,

3.

1 ,

4.

1 ,

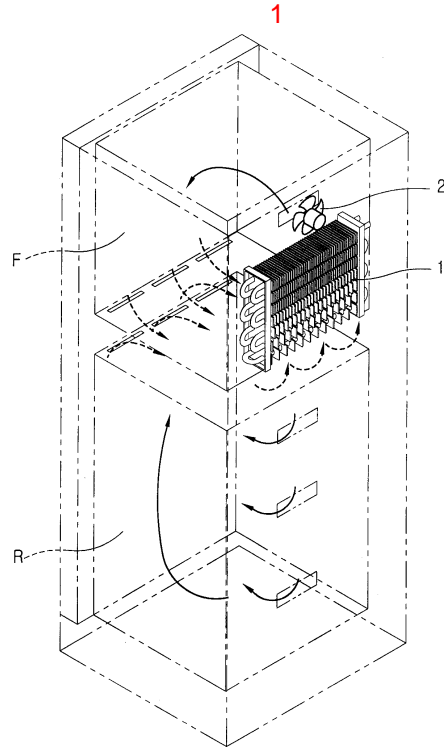

2

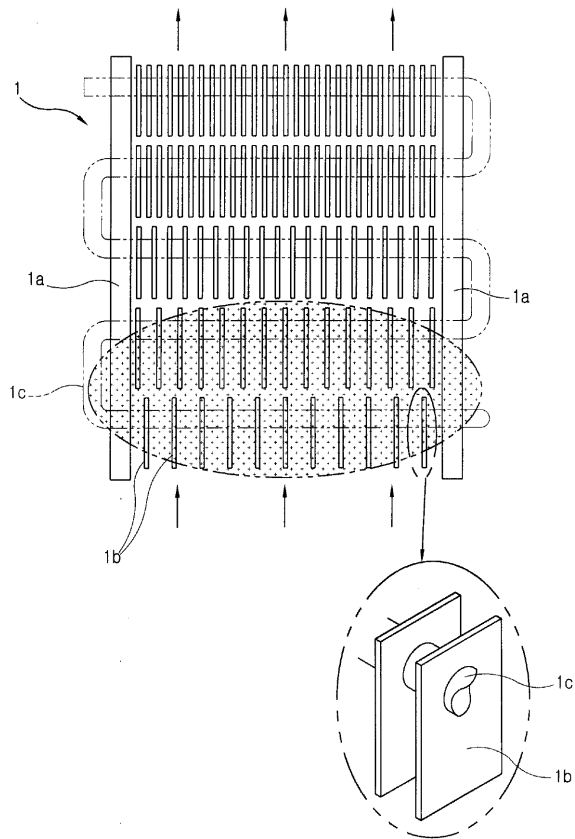

3

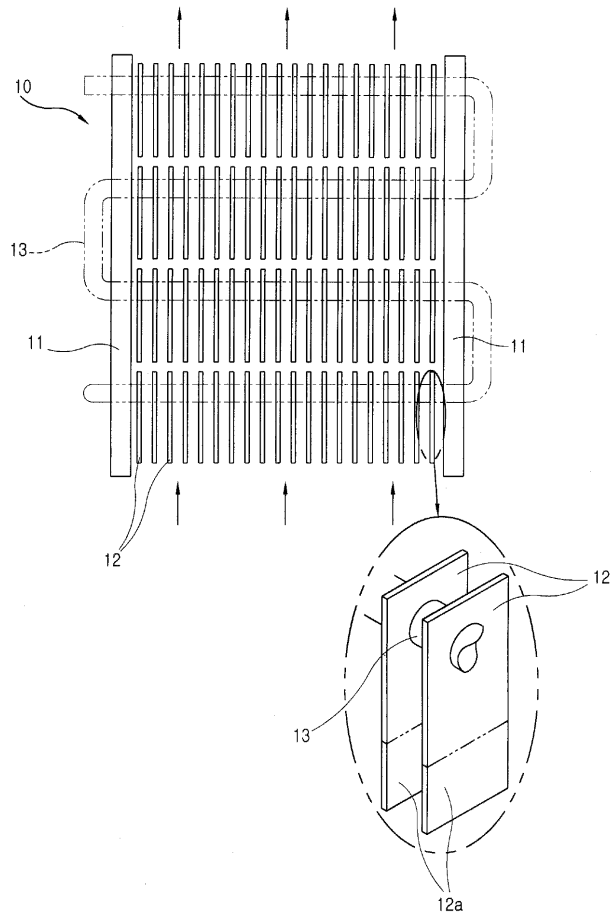

4

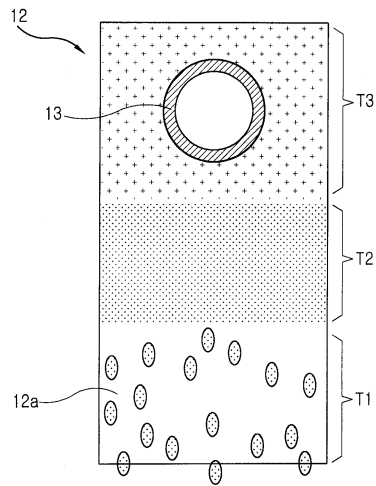

5

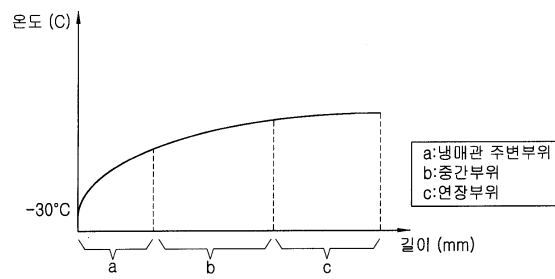

6a

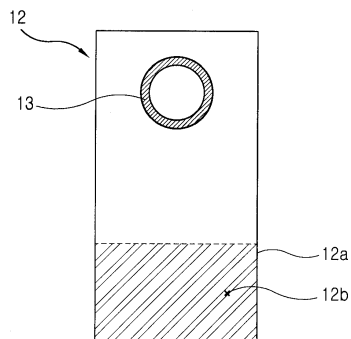

6b

