

W. H. WALDBY.

Grain Cleaner.

No. 36,250.

Patented Aug. 19, 1862.

Fig. 1,

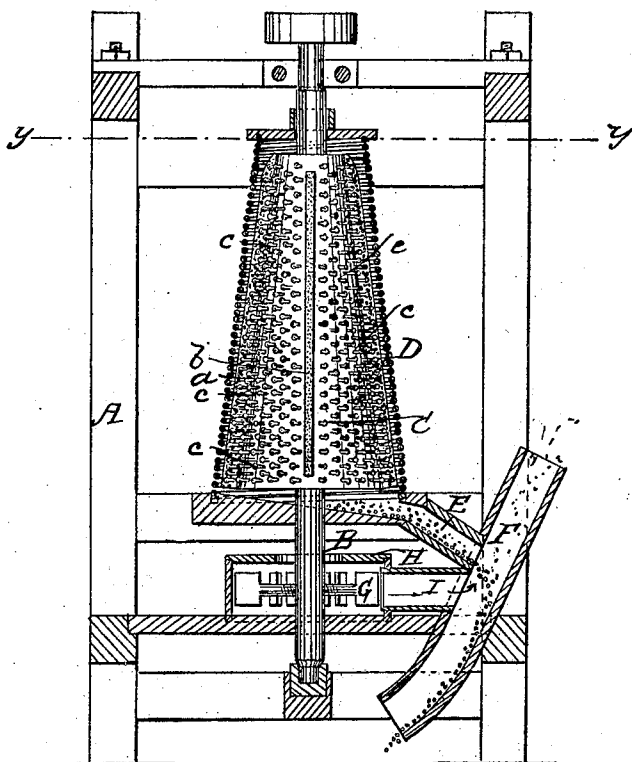

Fig. 2,

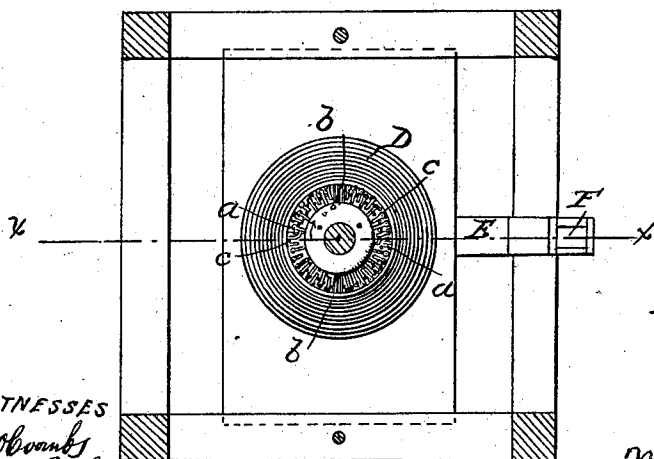
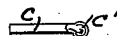

Fig. 3,



WITNESSES
Hobson
W. R. Reed

INVENTOR:
W. H. Waldbly
per Munn & Co
attorneys

UNITED STATES PATENT OFFICE.

WILLIAM H. WALDBY, OF COOPERSTOWN, NEW YORK.

IMPROVEMENT IN GRAIN-CLEANING MACHINES.

Specification forming part of Letters Patent No. 36,250, dated August 19, 1862.

To all whom it may concern:

Be it known that I, WILLIAM H. WALDBY, of Cooperstown, in the county of Otsego and State of New York, have invented a new and Improved Grain-Cleaning Machine; and I do hereby declare that the following is a full, clear, and exact description of the same, reference being had to the accompanying drawings, making a part of this specification, in which—

Figure 1 is a vertical central section of my invention taken in the line *x x*, Fig. 2; Fig. 2, a horizontal section of the same taken in the line *y y*, Fig. 1; Fig. 3, a detached view of one of the pins or teeth pertaining to the same.

Similar letters of reference indicate corresponding parts in the several figures.

The object of this invention is to obtain a compact and portable machine for scouring the grain and depriving the same of all impurities, such as smut, dirt, &c., whether mixed therewith in a loose state or connected to it so as to form a glazing thereon.

To this end the invention consists in the employment or use of a revolving frustum of a cone fitted within a corresponding-shaped screen and provided with teeth or scourers, beaters, and brushes, and using in connection therewith a blast-fan and discharge-spouts, all constructed and arranged as hereinafter fully shown and described.

To enable those skilled in the art to fully understand and construct my invention, I will proceed to describe it.

A represents a rectangular framing, which may be constructed in any proper way to support the working parts of the machine, and B is a vertical shaft, which is placed centrally in the framing A and has a frustum of a cone, C, secured permanently to it. This frustum of a cone, C, may be of wood, and it has two beaters or wings, *a a*, attached to its periphery at opposite sides thereof and extending its whole length or height. These beaters or wings may be of sheet metal, and slightly curved at their upper ends to give what is technically termed a "draft" or "feed."

To the periphery of C there are also secured two brushes, *b b*, at opposite sides, and, like the beaters or wings *a a*, extending its whole height or length, or nearly so. These brushes *b b* are formed of narrow straight rows of bris-

cles, as shown clearly in Fig. 1, and they are in planes at right angles to those of the beaters or wings *a a*, as shown clearly in Fig. 2. The periphery of C between the brushes and beaters or wings is filled with teeth or pins *c*, which are driven into it at about equal distances apart. The teeth or pins are formed of metal, and their outer ends are tinned or covered with a metal or composition, as shown clearly at *c'* in the enlarged view in Fig. 3. This tinning or covering of the ends of the teeth or pins *c* is an important feature of the invention, as it forms smooth terminals for the pins and prevents the latter from cutting or breaking the grain.

D represents a screen, which is formed of a wire of suitable size or diameter, wound spirally, so as to form a hollow frustum of a cone corresponding to C, suitable spaces being allowed between the curvolutions of the wire to admit of the egress of all light and fine impurities. The edges of the beaters or wings, brushes, and teeth or pins just clear the inner surface of the screen D.

E is an inclined spout which leads from the bottom of the screen D into a spout, F, inclined in a reverse direction to E, as shown in Fig. 1, and G is a fan, which is placed on the shaft B below the screen D. This fan is inclosed by a case, H, which communicates with the spout F, just below the spout E, by means of a horizontal tube, I.

The operation is as follows: The grain to be operated upon is fed into the upper end of the screen D and the shaft B is rotated by any convenient power. The grain passes down between the screen D and the frustum of a cone, C, and is subject to four different operations—a beating action by the beaters or wings *a a*, which also generate a blast, a brushing action by the brushes *b b*, and a scouring action by the teeth or pins *c*. By these means the smut and all impurities which may adhere to the grain will be effectually scoured from it and the greater portion expelled by the blast through the screen D. The grain is discharged from the lower end of screen D into spout E, and thence into spout F, where it is subjected to a blast from the fan G, which expels all the remaining light impurities which it may contain, and the cleaned grain falls from the lower end of the spout F.

From the above description it will be seen that the frustum of the cone C and screen D perform the principal part of the work, the several parts named—to wit, the beaters or wings *a*, brushes *b*, and teeth or pins *c*—subjecting the grain to the different actions or processes required in order to detach and break up the impurities which may adhere to it, while the fan G and spouts E F, arranged as shown, take out all the light loose impurities which may chance to escape from the screen D with the grain. An extremely simple, portable, and efficient device for the purpose is thereby obtained, and one which will not break

the grain, a result which attends the operation of the ordinary machines in use.

Having thus described my invention, what I claim as new, and desire to secure by Letters Patent, is—

The screen D and the frustum of a cone, C, provided with the beaters or wings *a a*, brushes *b b*, and teeth or pins *c*, in combination with the fan G and spouts E F, all arranged as and for the purpose herein set forth.

WM. H. WALDBY.

Witnesses:

J. A. LYNES,
SAML. A. BOWEN.