

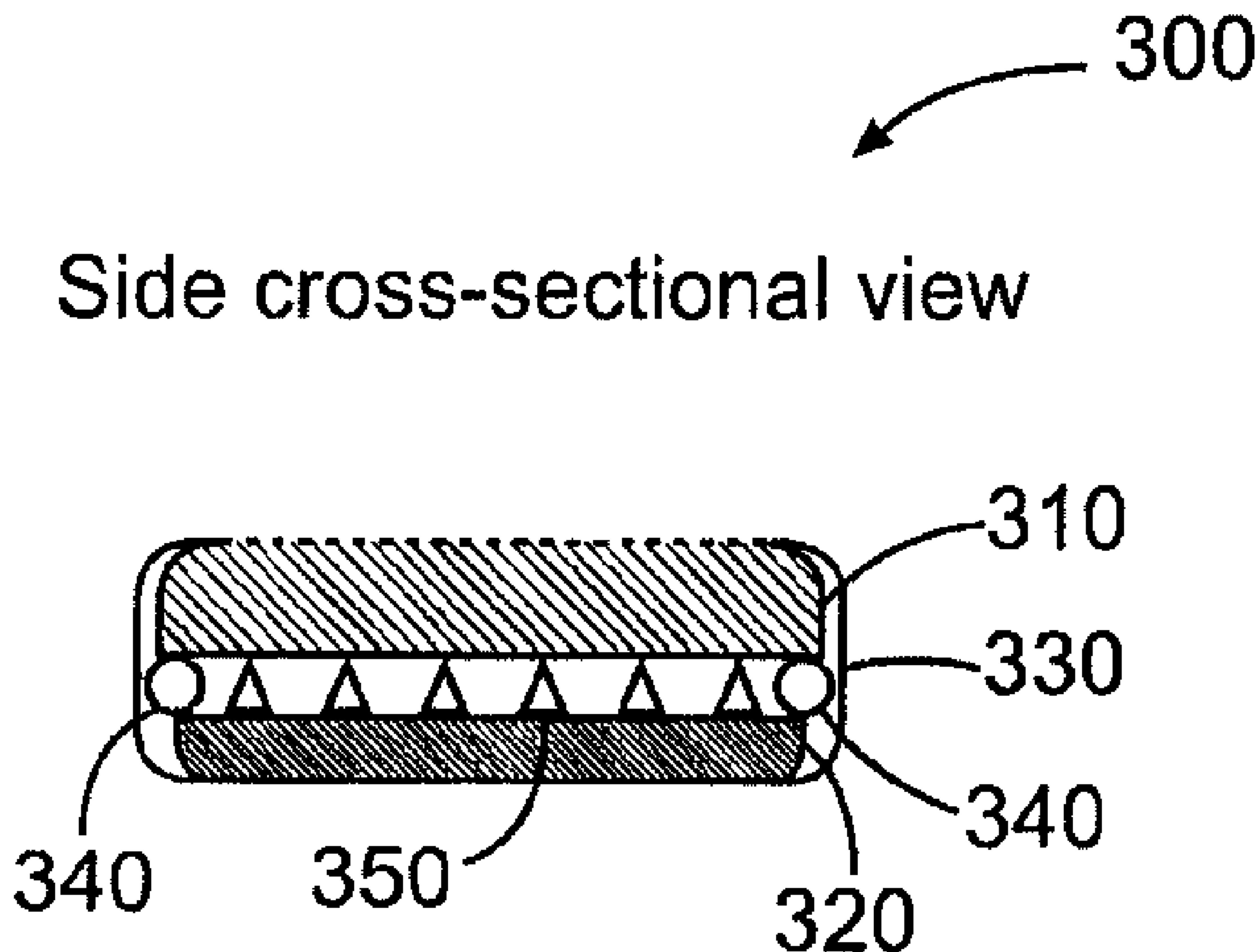

(86) **Date de dépôt PCT/PCT Filing Date:** 2013/10/17
 (87) **Date publication PCT/PCT Publication Date:** 2014/04/24
 (45) **Date de délivrance/Issue Date:** 2018/01/02
 (85) **Entrée phase nationale/National Entry:** 2015/04/16
 (86) **N° demande PCT/PCT Application No.:** US 2013/065439
 (87) **N° publication PCT/PCT Publication No.:** 2014/062920
 (30) **Priorité/Priority:** 2012/10/19 (US13/656,291)

(51) **Cl.Int./Int.Cl. E21B 43/22** (2006.01),
C09K 8/02 (2006.01), **E21B 27/00** (2006.01)
 (72) **Inventeur/Inventor:**
 HALL, LEE J., US
 (73) **Propriétaire/Owner:**
 HALLIBURTON ENERGY SERVICES, INC., US
 (74) **Agent:** PARLEE MCLAWS LLP

(54) **Titre : EMBALLAGES PASSIFS POUR LA LIBERATION D'AGENTS CHIMIQUES DANS DES Puits DE FORAGE**
 (54) **Title: PASSIVE DOWNHOLE CHEMICAL RELEASE PACKAGES**



(57) **Abrégé/Abstract:**

An apparatus for releasing chemical agents in a well bore, comprising: a packaging material; a chemical agent, wherein the chemical agent is contained within the packaging material; and an adhesive, wherein the adhesive is attached to the packaging material and associated methods.

(12) INTERNATIONAL APPLICATION PUBLISHED UNDER THE PATENT COOPERATION TREATY (PCT)

(19) World Intellectual Property
Organization
International Bureau(10) International Publication Number
WO 2014/062920 A1(43) International Publication Date
24 April 2014 (24.04.2014)

- (51) **International Patent Classification:**
C09K 8/02 (2006.01) *E21B 7/10* (2006.01)
- (21) **International Application Number:**
PCT/US2013/065439
- (22) **International Filing Date:**
17 October 2013 (17.10.2013)
- (25) **Filing Language:** English
- (26) **Publication Language:** English
- (30) **Priority Data:**
13/656,291 19 October 2012 (19.10.2012) US
- (71) **Applicant:** HALLIBURTON ENERGY SERVICES, INC. [US/US]; 10200 Bellaire Boulevard, Houston, Texas 77072 (US).
- (72) **Inventor:** HALL, Lee, J.; 21899 Valley Ranch Crossing Drive, Apt. 327, Porter, Texas 77365 (US).
- (74) **Agents:** BAEHL, Stephen et al.; Baker Botts LLP, 910 Louisiana Street, Houston, Texas 77002 (US).
- (81) **Designated States** (unless otherwise indicated, for every kind of national protection available): AE, AG, AL, AM,

AO, AT, AU, AZ, BA, BB, BG, BH, BN, BR, BW, BY, BZ, CA, CH, CL, CN, CO, CR, CU, CZ, DE, DK, DM, DO, DZ, EC, EE, EG, ES, FI, GB, GD, GE, GH, GM, GT, HN, HR, HU, ID, IL, IN, IR, IS, JP, KE, KG, KN, KP, KR, KZ, LA, LC, LK, LR, LS, LT, LU, LY, MA, MD, ME, MG, MK, MN, MW, MX, MY, MZ, NA, NG, NI, NO, NZ, OM, PA, PE, PG, PH, PL, PT, QA, RO, RS, RU, RW, SA, SC, SD, SE, SG, SK, SL, SM, ST, SV, SY, TH, TJ, TM, TN, TR, TT, TZ, UA, UG, US, UZ, VC, VN, ZA, ZM, ZW.

- (84) **Designated States** (unless otherwise indicated, for every kind of regional protection available): ARIPO (BW, GH, GM, KE, LR, LS, MW, MZ, NA, RW, SD, SL, SZ, TZ, UG, ZM, ZW), Eurasian (AM, AZ, BY, KG, KZ, RU, TJ, TM), European (AL, AT, BE, BG, CH, CY, CZ, DE, DK, EE, ES, FI, FR, GB, GR, HR, HU, IE, IS, IT, LT, LU, LV, MC, MK, MT, NL, NO, PL, PT, RO, RS, SE, SI, SK, SM, TR), OAPI (BF, BJ, CF, CG, CI, CM, GA, GN, GQ, GW, KM, ML, MR, NE, SN, TD, TG).

Published:

- with international search report (Art. 21(3))

(54) **Title:** PASSIVE DOWNHOLE CHEMICAL RELEASE PACKAGES

Fig. 3C

Side cross-sectional view

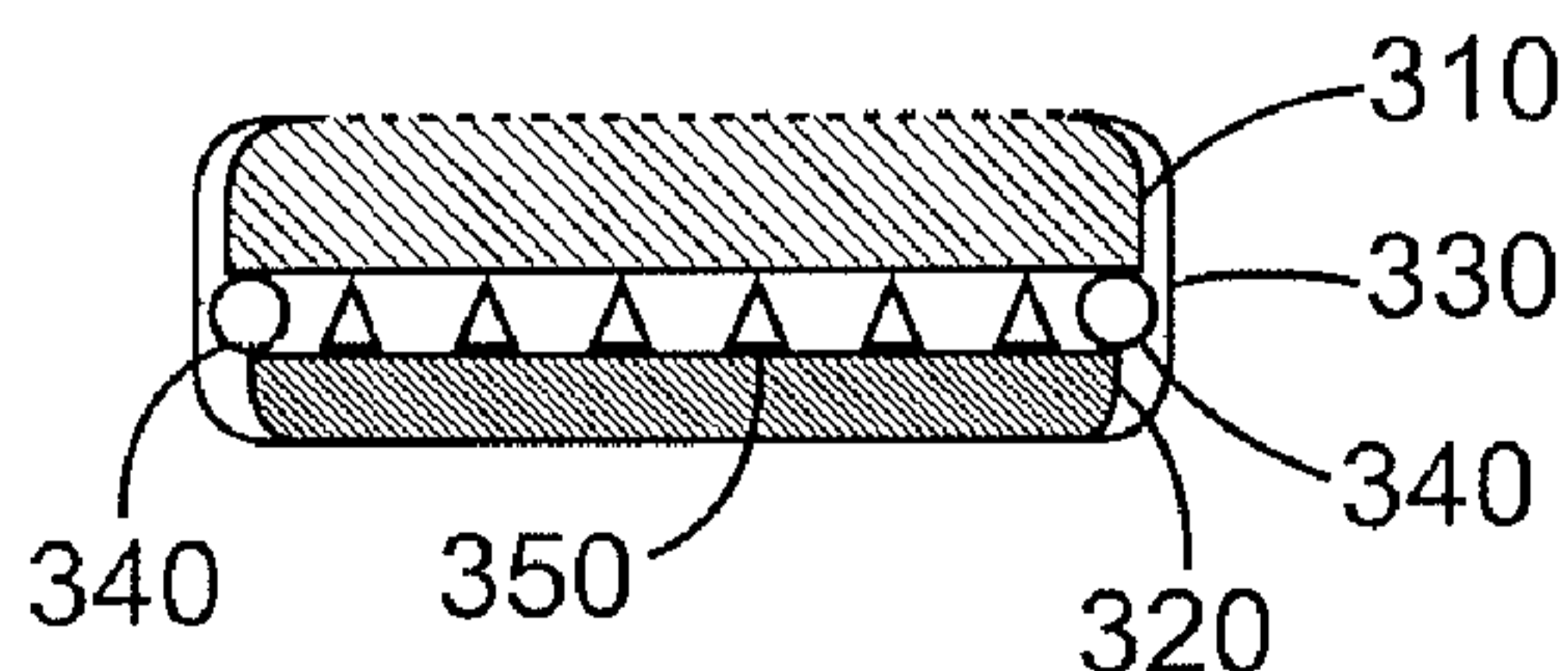

(57) **Abstract:** An apparatus for releasing chemical agents in a well bore, comprising: a packaging material; a chemical agent, wherein the chemical agent is contained within the packaging material; and an adhesive, wherein the adhesive is attached to the packaging material and associated methods.



WO 2014/062920 A1

PASSIVE DOWNHOLE CHEMICAL RELEASE PACKAGES**CROSS-REFERENCE TO RELATED APPLICATIONS**

5 This application claims priority to U.S. Patent Application Serial Number
13/656,291 filed 19 October 2012.

BACKGROUND

10 [0001] The present disclosure relates generally to passive downhole chemical
release packages and more particularly, in certain embodiments, the present disclosure relates
to passive downhole chemical release packages capable of releasing chemical agents at
desired locations in a well bore and associated methods.

15 [0002] A wide variety of chemicals may be used within a well bore in
connection with producing hydrocarbons or reworking a well that extends into a hydrocarbon
formation. Chemicals such as free radical initiators, catalysts (e.g. cement curing agents,
gelling agents, mud-to-cement agents, etc.), lubricants, contrast agents, acid gas scavenger
materials (for H₂S, CO₂, etc.), filter-cake breakers, sensors, and indicators are commonly
used. Such chemicals are well known in the art.

20 [0003] A persisting problem in the drilling of wells is the ability to trigger
chemical reactions downhole on demand. Two different flow regimes may be required to
properly stage downhole reactions in a conventional operation: Laminar flow, taking place at
a relatively slower rate, is needed to place the chemical of interest at a desired depth, while
turbulent flow, requiring a fast pumping rate, would be needed to mix chemicals. The
transient pressure changes induced by changing the pump rate of the fluids may be enough to
25 cause undesired well bore instability. These considerations are exacerbated by the long
length scale of the drillstring and the continuous flow of fluids through the drill pipe and the
annulus, making it difficult to stage the mixing of any two reagents at a specified depth or
location, or to initiate their desired reaction at a specified time. As a result, companies and
personnel managing drilling rigs are often resistant to the practice of changing pump speeds
30 to facilitate the requirements of drilling fluids over the course of applications.

 [0004] One approach proposed in the past is to use encapsulated or otherwise
protected chemicals which are added to fluids at the top of the drill string and pumped down
the well bore. The encapsulating material could be tuned to degrade at a predetermined
condition naturally occurring along the drillstring, which typically has gradients of increasing

WO 2014/062920

PCT/US2013/065439

temperature and pressure with increasing depth. The limitation of this approach is that the encapsulated chemical could only react with other chemicals nearby in the suspending fluid, within a spatial zone governed by diffusion and turbulent mixing, or on a limited length scale. It may be desirable to have a deployment means to release one or more chemicals into the
5 annulus between the well bore and the casing so that the chemicals need not be pumped from the surface at the top of the well bore. Such an approach could be used to protect surface equipment such as pumps, lines, tanks, mixers, or solids control equipment from reactive chemicals

BRIEF DESCRIPTION OF THE DRAWINGS

[0005] These drawings illustrate certain aspects of some of the embodiments of the present invention, and should not be used to limit or define the invention.

5 [0006] Figures 1A-1C illustrate top, bottom, and side views of a first embodiment of a downhole chemical release package, incorporating aspects of the present disclosure.

[0007] Figures 2A-2C illustrate top, bottom, and side views of a second embodiment of a downhole chemical release package, incorporating aspects of the present disclosure.

10 [0008] Figures 3A-3C illustrate top, bottom, and side views of a third embodiment of a downhole chemical release package, incorporating aspects of the present disclosure.

[0009] The features and advantages of the present invention will be apparent to those skilled in the art from the description of the preferred embodiments which follows
15 when taken in conjunction with the accompanying drawings. While numerous changes may be made by those skilled in the art, such changes are within the spirit of the invention.

[0010] While embodiments of this disclosure have been depicted and described and are defined by reference to example embodiments of the disclosure, such references do not imply a limitation on the disclosure, and no such limitation is to be inferred.
20 The subject matter disclosed is capable of considerable modification, alteration, and equivalents in form and function, as will occur to those skilled in the pertinent art and having the benefit of this disclosure. The depicted and described embodiments of this disclosure are examples only, and not exhaustive of the scope of the disclosure.

DETAILED DESCRIPTION

[0011] The present disclosure relates generally to passive downhole chemical release packages and more particularly, in certain embodiments, the present disclosure relates to passive downhole chemical release packages capable of releasing chemical agents at
5 desired locations in a well bore and associated methods.

[0012] Illustrative embodiments of the present invention are described in detail herein. In the interest of clarity, not all features of an actual implementation may be described in this specification. It will of course be appreciated that in the development of any such actual embodiment, numerous implementation-specific decisions may be made to
10 achieve the specific implementation goals, which may vary from one implementation to another. Moreover, it will be appreciated that such a development effort might be complex and time-consuming, but would nevertheless be a routine undertaking for those of ordinary skill in the art having the benefit of the present disclosure.

[0013] The present disclosure offers a low cost, low risk solution for staging
15 triggered chemistry downhole using existing tubular goods infrastructure. In certain embodiments, the present disclosure describes a cheap, one time use package (or group of packages) that can be readily affixed to a drillstring without the use of special pipe or equipment. The present disclosure relates to processes of encapsulating chemicals within a degradable chemical package, affixed to a strong adhesive, which could then be attached to a
20 drill pipe, casing, liner, or other tubular.

[0014] To facilitate a better understanding of the present disclosure, the following examples of certain embodiments are given. In no way should the following examples be read to limit, or define, the scope of the disclosure. Embodiments of the present disclosure may be applicable to horizontal, vertical, deviated, or otherwise nonlinear
25 wellbores in any type of subterranean formation. Embodiments may be applicable to injection wells as well as production wells, including hydrocarbon wells.

[0015] In certain embodiments, the present disclosure provides an apparatus for releasing chemical agents in a well bore, comprising a chemical package and an adhesive. Referring now to Figure 1, Figures 1A-C illustrate top, bottom, and side views of a downhole
30 chemical dispenser 100 comprising a chemical package 110 and adhesive 120 in accordance with a first embodiment of the present disclosure.

[0016] Downhole chemical dispenser 100 may be any shape suitable for use in a tubular. In certain embodiments, chemical dispenser 100 may be disk-shape, cylindrical, conical, spherical, hemispherical, or ellipsoidal. In other embodiments, chemical dispenser

WO 2014/062920

PCT/US2013/065439

100 may have cut sections. In certain embodiments, downhole chemical dispenser 100 may be placed within a tubular or attached to a tubular.

[0017] In certain embodiments, chemical package 110 may comprise a chemical agent contained or encapsulated within a packaging material. Suitable chemical agents include any chemical agent suitable for use in a subterranean formation. Examples of suitable chemical agents include, but are not limited to, free radical initiators, catalysts (e.g. cement curing agents, gelling agents, mud-to-cement agents, etc.), lubricants, contrast agents, acid gas scavenger materials (for H₂S, CO₂, etc.), filter-cake breakers, sensors, and indicators. The chemical agent may be in any state, however condensed states such as liquids or solids are preferred due to the relatively small volume of each package. Suitable packaging materials include any packaging material that is capable of degrading downhole to release the chemical agents. For example, the packaging material may be capable of releasing the chemical agent by employing any one of the following: a polymer film or coating which dissolves in a well bore fluid (e.g. water based mud, oil based mud, or some constituent thereof); a polymer film or coating which melts at elevated temperature within the well bore; a polymer film which swells in solvent or electrolyte, thus allowing diffusion; a polymer film or coating which becomes rubbery above its glass transition temperature (T_g), thus allowing diffusion; a polymer film or coating which mechanically ruptures or breaks; a material which is compressed with polymer binder granules which dissolve or swell; a solid material reactant which dissolves in a well bore fluid; a solid material which is eroded or ablated away by the flow of solids-laden well bore fluids. Examples of such film-like packaging materials include but are not limited to polymer films such as polylactic acids, cellulose, or other polysaccharides, polyethylenes, polyacrylic acids polyvinyl alcohols, urethanes, epoxies, silicones, styrenes, or copolymers thereof. Examples of suitable porous packaging materials include but are not limited to: natural and synthetic sponges, pumice, partially pyrolyzed wood, aerogels and hydrogels, fritted or otherwise sintered metals, glasses, and ceramics, cardboard, paper, and other woven or non-woven fibrous structures with porosity. The particular packing material may be tuned to degrade at a chosen range of temperature, pressure, pH, reactant concentration, or fluid velocity through prior processing.

[0018] In certain embodiments, adhesive 120 may comprise a chemical adhesive or a magnet. Examples of suitable chemical adhesives include epoxies, cellulose derivatives, isocyanates, urethanes, acrylics, cyanoacrylics, etc. Examples of suitable magnets include Nd alloy (Nd₂Fe₁₄B), Sm alloy (SmCo₅; Sm(Co, Fe, Cu, Zr)₇), "Alnico"

WO 2014/062920

PCT/US2013/065439

alloy (Fe-Al_x-Ni_y-Co_z), or Sr-ferrite alloy magnets. The adhesive 120 may be attached to the chemical package 110 and to a tubular.

[0019] In certain embodiments, the downhole chemical dispenser may further comprise a housing. Figures 2A-C illustrate top, bottom, and side views of a downhole chemical dispenser 200 comprising a chemical package 210, and adhesive 220, and a housing 230 in accordance with another embodiment of the present disclosure. Downhole chemical dispenser 200, chemical package 210, and adhesive 220 may share common features with the downhole chemical dispenser 100 shown in Figure 1.

[0020] In certain embodiments, housing 230 may comprise a top 232. In certain embodiments, top 232 may comprise a perforated top. In other embodiments, top 232 may comprise a mesh of arbitrary porosity. Housing 230 and top 232 may be made of any rigid materials. Examples of such rigid material include, but are not limited to, metals and polymers. Examples of suitable metals include sheets and screens of SAE 304 or 316 stainless steel. Housing 230 may partially or completely encase chemical package 210 and adhesive 220. In certain embodiments, housing 230 may encase downhole chemical dispensers 200 in such a manner that top 232 is positioned above the chemical package 210 and a portion of the adhesive 220 remains un-encased, as shown in Figure 2.

[0021] In certain embodiments, the downhole chemical dispenser may further comprise a pressure activated release mechanism. Figures 3A-C illustrate top, bottom, and side views of a downhole chemical dispenser 300 comprising a chemical package 310, an adhesive 320, housing 330, O-ring 340, and puncture points 350 in accordance with another embodiment of the present disclosure. Downhole chemical dispenser 300, chemical package 310, adhesive 320, and housing 330 may share common features with the downhole chemical dispensers 100 and 200 shown in Figures 1 and 2.

[0022] In certain embodiments, O-ring 340 may comprise any flexible material capable of maintaining an air gap. In certain embodiments, puncture points 350 may comprise any hard material such as a metal, ceramic, or a polymer. In certain embodiments, puncture points 350 may comprise ends of wires in a screen. O-ring 340 may be positioned between the chemical package 310 and adhesive 320 such that, at atmospheric conditions, an air gap is formed between chemical package 310 and adhesive 320. When under a selected pressure, the air gap formed between chemical package 310 and adhesive 320 may compress allowing the puncture points 350 to pierce the chemical package 310 to facilitate the release of a chemical agent. The selection of O-ring 340 and puncture points 350 may allow for the collapse of the air gap and the puncture of the chemical package at specific pressures.

WO 2014/062920

PCT/US2013/065439

[0023] In certain embodiments, the downhole chemical dispensers discussed herein may be used to deploy a chemical agent in a well bore at a specific reaction zone. In certain embodiments, the downhole chemical dispensers discussed herein may allow for the dispensing of a chemical agent via the degradation rate of its packaging material in the context of fluid flowing past a stationary package. In other embodiments, the downhole chemical dispenser discussed herein may be added to any section of a drill pipe and may move with the drillstring as it descends during drilling operations, regardless of the flow velocity of fluids.

[0024] In one embodiment, the present disclosure provides an apparatus for releasing chemical agents in a well bore, comprising: a packaging material; a chemical agent, wherein the chemical agent is contained within the packaging material; and an adhesive, wherein the adhesive is attached to the packaging material.

[0025] In another embodiment, the present disclosure provides a method of delivering a chemical agent comprising: providing a downhole chemical release package, the downhole chemical release packaging comprising a packaging material, a chemical agent contained within the packaging material, and an adhesive attached to the packaging material; introducing the downhole chemical agent into a subterranean formation; and allowing the downhole chemical release package to release the chemical agent.

[0026] In another embodiment, the present disclosure provides a method comprising: providing a tubular; attached a downhole chemical release package to the tubular, the downhole chemical release package comprising a packing material, a chemical agent contained within the packing material, and an adhesive attached to the packing material; introducing the tubular into a subterranean formation; and allowing the downhole chemical release package to release the chemical agent.

[0027] To facilitate a better understanding of the present invention, the following examples of certain aspects of some embodiments are given. In no way should the following examples be read to limit, or define, the entire scope of the invention.

EXAMPLES

[0028] **Example 1 - Applications in production**

[0029] During production, several packages may be distributed along production casing and may be setup to release different unique tracer molecules which would correspond to different production zones. By monitoring the tracer molecular profile at the top of the well, the relative production rates of different zones may be inferred.

[0030] Example 2 - Applications in cementing

[0031] Several packages containing cement hardening accelerators could be placed on the outside of a casing and placed within a well bore. Once the cement level in the annular space reaches the package, the package could degrade on contact with the caustic pH
5 of the cement, helping to seal the well bore.

[0032] Example 3 - Applications in scavenging

[0033] The chemical package could be a highly porous solid material incorporating an H₂S scavenging material such as ZnO. In this case, the package may actually remove a hazardous chemical (H₂S) replacing it with water by the following
10 equation: $ZnO + H_2S \rightarrow ZnS + H_2O$.

[0034] Example 4 - Application in well bore strengthening

[0035] The chemical package may be affixed to the inside or outside of a drill pipe, drill collar, or bottom hole assembly and tuned to degrade at a narrow range of elevated downhole temperatures to release a lost circulation material. Utilizing this method, lost
15 circulation materials with strong plugging abilities would not need to be constantly re-circulated with the drilling fluid, saving wear and tear on pumps. Any unused amount returning to the surface via the annular space could still be removed from the drilling fluid with cuttings or fine solids.

[0036] Therefore, the present disclosure is well adapted to attain the ends and
20 advantages mentioned as well as those that are inherent therein. The particular embodiments disclosed above are illustrative only, as the present disclosure may be modified and practiced in different but equivalent manners apparent to those skilled in the art having the benefit of the teachings herein. Furthermore, no limitations are intended to the details of construction or design herein shown, other than as described in the claims below. It is therefore evident
25 that the particular illustrative embodiments disclosed above may be altered or modified and all such variations are considered within the scope and spirit of the present disclosure. Also, the terms in the claims have their plain, ordinary meaning unless otherwise explicitly and clearly defined by the patentee. The indefinite articles "a" or "an," as used in the claims, are defined herein to mean one or more than one of the element that it introduces.

What is claimed is:

1. An apparatus for releasing chemical agents in a well bore, comprising:
a downhole chemical release package, wherein the downhole chemical release package is directly coupled to a tubular and comprises:
 - 5 a packaging material, wherein the packaging material defines a top surface of the downhole chemical release package extending away from the tubular;
 - a chemical agent, wherein the chemical agent is contained within the packaging material;
 - an adhesive, wherein the adhesive is attached to the packaging
10 material, wherein the adhesive defines a bottom surface of the downhole chemical release package opposite the top surface, and wherein the adhesive directly couples the downhole chemical release package to the tubular; and
 - a pressure activated release mechanism, wherein the pressure activated release mechanism comprises:
 - 15 a flexible ring disposed between the packaging material and the adhesive such that, at atmospheric conditions, an air gap is formed between the packaging material and the adhesive; and
 - a plurality of puncture points disposed between the packaging material and the adhesive such that, at a selected pressure, the air gap compresses to allow the
20 plurality of puncture points to pierce the packaging material.
2. The apparatus of claim 1, wherein the packaging material comprises at least one material selected from the group consisting of: silicones, nanocelluloses, natural and synthetic sponges, pumice, wood, partially pyrolyzed wood, aerogels and hydrogels, fritted and/or sintered metals, ceramics, composite cardboard, paper
25 compositions and combinations thereof.
3. The apparatus of claim 1, wherein the adhesive comprises a magnet.
4. The apparatus of claim 1, further comprising a housing which encases at least a portion of the packaging material and at least a portion of the adhesive.
5. The apparatus of claim 4, wherein the housing comprises a perforated
30 top section disposed over the top surface of the downhole chemical release package.
6. A method of delivering a chemical agent comprising:

providing a downhole chemical release package, the downhole chemical release package comprising a packaging material defining a top surface of the downhole chemical release package, a chemical agent contained within the packaging material, an adhesive attached to the packaging material and defining a
5 bottom surface of the downhole chemical release package opposite the top surface, and a pressure activated release mechanism, wherein the pressure activated release mechanism comprises:

a flexible ring disposed between the packaging material and the adhesive such that, at atmospheric conditions, an air gap is formed between the
10 packaging material and the adhesive; and

a plurality of puncture points disposed between the packaging material and the adhesive;

coupling the downhole chemical release package to a tubular such that the top surface of the downhole chemical release package extends from the tubular, by
15 directly coupling the adhesive to the tubular;

introducing the downhole chemical agent into a subterranean formation; and

allowing the downhole chemical release package to release the chemical agent.

7. The method of claim 6, wherein the packaging material comprises at
20 least one material selected from a group consisting of: silicones, nanocelluloses, natural and synthetic sponges, pumice, wood, partially pyrolyzed wood, aerogels and hydrogels, fritted and/or sintered metals, ceramics, composite cardboard, paper compositions and combinations thereof.

8. The method of claim 6, wherein the adhesive comprises a magnet.

9. The method of claim 6, wherein the downhole chemical release
25 package further comprises a housing, wherein the housing at least partially encases the packaging material and at least partially encases the adhesive.

10. The method of claim 9, wherein the housing comprises a perforated top section disposed over the top surface of the downhole chemical release package.

11. The method of claim 6, wherein allowing the downhole chemical
30 package to release the chemical agent comprises:

compressing the air gap at a selected pressure; and

allowing the downhole chemical release package to be punctured by the plurality of puncture points.

12. A method comprising:

providing a tubular;

5 attaching a downhole chemical release package directly to the tubular, the downhole chemical release package comprising a packaging material defining a top surface of the downhole chemical release package, a chemical agent contained within the packaging material, and an adhesive attached to the packaging material and defining a bottom surface of the downhole chemical release package opposite the top
10 surface, wherein the adhesive directly attaches the downhole chemical release package to the tubular such that the top surface of the downhole chemical release package extends from the tubular, wherein the downhole chemical release package further comprises a pressure activated release mechanism, the pressure activated release mechanism comprising:

15 a flexible ring disposed between the packaging material and the adhesive such that, at atmospheric conditions, an air gap is formed between the packaging material and the adhesive; and

a plurality of puncture points disposed between the packaging material and the adhesive;

20 introducing the tubular into a subterranean formation; and

allowing the downhole chemical release package to release the chemical agent.

13. The method of claim 12, wherein the packaging material comprises at least one material selected from a group consisting of: silicones, nanocelluloses,
25 natural and synthetic sponges, pumice, wood, partially pyrolyzed wood, aerogels and hydrogels, fritted and/or sintered metals, ceramics, composite cardboard, paper compositions and combinations thereof.

14. The method of claim 12, wherein allowing the downhole chemical release package to release the chemical agent comprises allowing the downhole
30 chemical release package to be punctured by a pressure activated release mechanism.

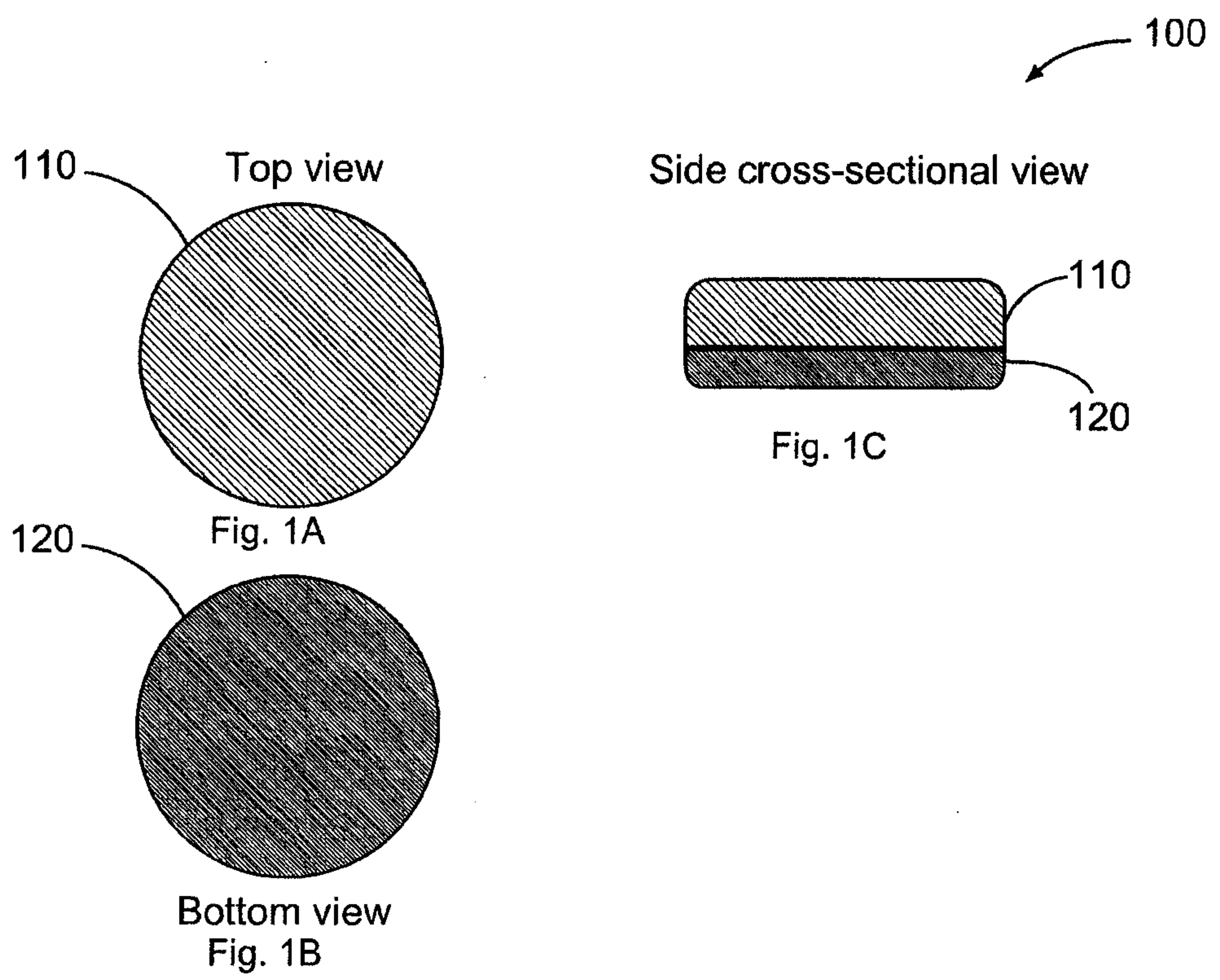

2/2

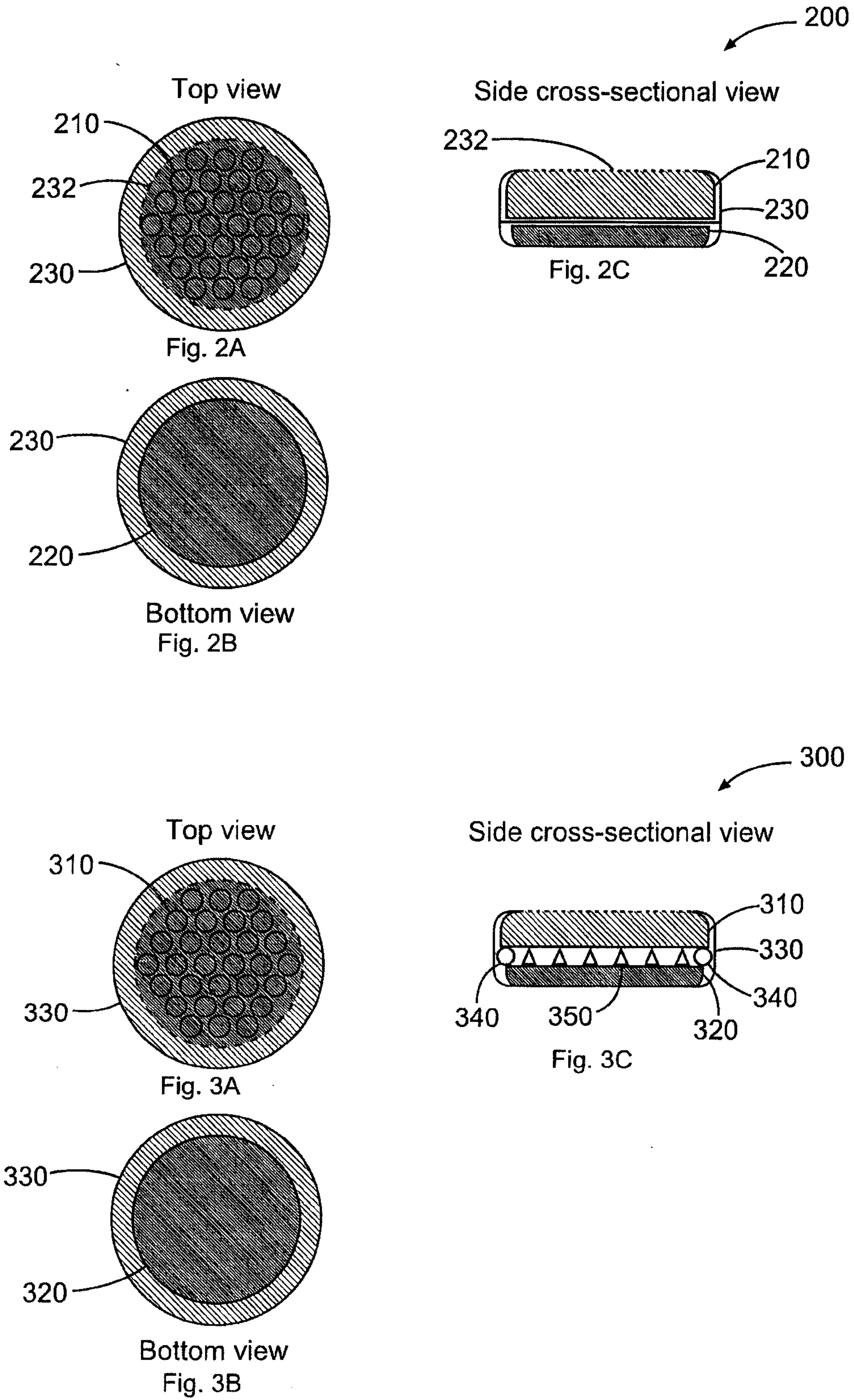

300



Side cross-sectional view

