

(19)
(12)

(KR)
(B1)

(51) 。 Int. Cl. 7
C23C 14/34

(45)
(11)
(24)

2001 12 28
10 - 0313966
2001 10 25

(21) 10 - 1994 - 0031408
(22) 1994 11 24

(65) 1995 - 0015648
(43) 1995 06 17

(30) 08/157763 1993 11 24 (US)
08/236715 1994 04 29 (US)

(73) ,
95054 3050

(72) 94028 190
95030 가 ? 19311
94402 1583

(74)
:

(54)

() 가 () O

43 39

44 43 44 - 44

*

70 : / 71 :

77 : 72 :

73 : 127 :

79 :

[]

가
 가 " "() 가
 ()

가

가 (,) () 가

() 가

, 가 가 가

가, 가

1

가

2

2

(66)

1

(65)

1

(63)

(60)

(61)

(64)

()

(62)

1

가

Carlos dos Santos Pereira Ribeiro

4,825,584

1

2

(55)

(50)

(54)

(52)가

(53)

(54)

(50)

(52)

(50)

(50)

(51)

(52)

가

(57)

(58)

(53)

(sweep)

()

가

(57)

가

(57)

(51)

(53)

(1 torr) 가

가

(

)

(51)

가

(53)

가

(51)

가

(50)

(51)

(deflection)

가

가

가

가

가가

가

가

가 510mm x 620mm

570mm x 720mm

, 가 가

(defect) 가 (brazing) 가 / 가

(gradient)가 () 가

() 가 ()

() 가 () 가

가

가

가

가

()

가

가

가

가

가

가

70%

()

()

가

가

(G - 11/FR4)

가

가
가

가 가

가
, 가

가 2 3

가 가 가

가

[]

| | | | | | | | |
|------|------|-----------|-------|---|------|-------|-------|
| (71) | 3 | (77) | (127) | / | (70) | (127) | (73)(|
|) | / | (70) | (72) | . | (77) | (73) | (73) |
| 108) | (77) | (105,106) | (109) | . | (77) | . | (|

3

[]

| | | | | | |
|---|------|---|---|------|------|
| 4 | (77) | 5 | 6 | (79) | (80) |
| | (79) | | | (79) | (87) |

(82) (79) (6). (127) (125)가 (

6 8) (82) () 7 ()
127) (128)가 (127,128) (82)
.O (93; 7 11 129) (82)
/ (70) 0 ()

(95; 5, 6, 14 16 , 125; 7, 8 10) (87)
(95)
90) 가 (13). 14 (80) ()
) (102) (95) 가 (103) (102) (95) ()
(95) (99) (95) 가 (9)
9) 가 (95) 가 가 가

(92; 4 5) 가 (87)
(95) 가 ,
(83 86) 가

7, 8, 9, 10 11 (77)

7 4, 5 6 (130) (125)

8 7

9 (127) (70) 가 (128)
(125) (128)
(130) (125)

10 가

11 (128)
(126)

(4), (83,84,85,86) (91)

05, 106) (12) , - (87 3 90) (1)

(14) , (95) 0.425 (10.8mm) 가 , (96a) 1,000
(25.4mm) (101) 0.25 (6.4mm) , (96) (100) 0.375 (9.5mm)
(95) (97) (83,84)
4 (85, 86) 가 (9)

5) (93) (97) (95) / (83 - 86) O
(105, 100) (77)

가

15, 16

가 가 가

15, 16

(가)

, 122 (50) () 5 가
(95) (98) 가

(,) 14, 16
/ (103)

American Cyanamid Company; Bloomingdale Plant, Hav

re de Grace, Maryland

가 0.013 (0.33mm) "FM 300 - 2K"

20 ± 5 psi(0.14 ± 0.03MPa) (95) (80) 가

30 250 ± 5 (120 ± 3) . 250 (120)

가 90 . FM 300 - 2K FM 300(- M

- K) Autoclave(, 가 - 가)

90 350 (177) 50 ± 10 psi(3.45 ± 0.69MPa)

가

.(17

18)

가 ()

17 18 (87) (110), , 0.25(6.35mm)

(111) (95) 가 (130)

(111) (111) 17 19 (112)

18 (111)

가 19 28

19 (171) (172)

가 / (172)

(197) (23 - 26)

(202) (17f) (172) (197)

가 (202) (174) (O , ,)

, O , , , O (177) (198; 22 ,
) O (177) (172)
 (209 ; 36) (191)
 (155 ; 33)
 O (198) (174; 20) O (176)
 . O (201) (176) (197) (171)
 가 가 O (201) 가
 20 (20 - 20) 19 (175) (174)
 . O (201; 26) 20 (172)
 (173)
 21 (21 - 21) 19 O (177) (172)
 8) O (198) 가 (17)
 22 가 O (177) . O (198) 22 O
 O (198) 22 O (177) (197)가 가
 O O (191) O (194)
 가 U (195)
 23 (200)
 24 (197) (171) 가 (199)
 가 가 가
 25 (25 - 25) 27 (213) 26 25
 (181) (171)
 O 가
 (202) (countersunk) G - 11 (204) . G - 11 (274) 1/16"
 (197) G - 11 가 가 (171) 가
 (1.59mm) G - 11 (187) 가 가 O 가
 가 가
 27 28 (171)

O (182) (183, 193) (183)
 O (193) O (191) 가
 O (229) O (783) O
 (193) (192) (191)
 O (183)

27 28 (189)

[]

29 (127)
 0.1 μ m No.600
 i) (128) (127) 가 ASM .750 가 2 MPa(290ps
 875 - 885 가 60

가 0.1 μ m No.600
 750 가 50MPa(700psi) 가 ASM
 psi) (10⁻⁷ 10⁻⁹) 1 875 - 885 가 50MPa(770
 가

850 Ti/6Al/4V 100psi(0.69MPa)
 (CP Grade 2) 가 Ti/6Al/4V()
 가)
 25) (125) G - 11 (130)
 (130) (125) G - 11

(125)가 Ti/6Al/4V 30
 (128) 850 (1562) 가 (12) 4MPa 90 100
 0.4 /sec(0.7 /sec) 4MPa(580psi)
 0.1 /sec(0.18 /sec) (130) (125) G - 11

17⁸ H₂/H₂O 10⁸ 10⁹ CO/CO₂ 10⁻⁸ torr 가 , 10⁷

500psi(3.45MPa) 가 4 가 420 가

, Herrera Hosokawa

[]

31
 / (138) (145) (146)
 . 가 (146; pedestal) (127)
 / (138) - (142) (142)
 O (139) 가 , () (138) / (138) O 73
) (138) (134) (3) O
 (136), O (135) (137) . O
 가 (134) (138) (133) (133)
 (132) (128)

(124) (127), (128), 가
 (125) O (124) O ()
 (133) O (129) (138) (1)
 32) (134) (137)

(124)가 O 가 O (119) O (118) 가 (1
 , (125) . (125)
 G11 가

가 , (117) (134) (13)
 (120) 가 (134) (117)

32 (114) (138) (134) (156) (116) (11)

3) . 가 (113) (117) (113) (110) . (138)가 (10⁻⁸ torr)

(113) (114) (, 1torr) 1 torr

10,330kg 13.6kg 1 torr . 1 sq. 30lbs. 가 . 23,000lbs. 10 torr 10 torr 가

(114,138)

(138) (113) (1 torr) . 10⁻⁹ torr

(138) 가 10⁻³ torr

(114)

2 (134) () (133) O (138) 가 . 3

(140) . 0.09 (2.3mm) 가 (155) 가 .

(140) (134)

가 (113)

33 31, 32 (158) (124) . (124) 가

가 , 2ft 200K ohm/in. () 가 (124)

(92) . (155) (117) (113)

34 (142) (132) (138) (142) (134) (133) (158) (134)

(134) (138) (124) (117) (124) 34

35 33 (159) (117)

(134) (158) (734) (124)

가 가 (155) (113)

가 36 - 40

38 19 (163) (156) 가 (156) (163) O (

229) 가 (216) 가 (216)

(191) (133) 가

27,28 (193) (192) (210) (209) 가

(217) (216) (217)

39 40 39 36, 37

36 - 36, 37 - 37 40 (163) 가 가 (213)

(231,232) (279) (233) (163) (224)

(220) (103) (147), (144)

(222), (146) (142)가

(279) (191) (156)

(191) (163) (156)

(133) (103) (216)

(215) (213) (13)

(216) (209)

37 (215) . O 가 (213)

O 가 19 (179abcd)
SAE 가 (hex nipple) 가

39, 40 (234) (138,209) 가

[]

41 (128) (155) 42
(241)

246) (242) (113) (114) (247) O (248) (
(50) (92) O (248) , (deflection)
(51) 가 , 가 ,

가 510mm x 620mm 가 570mm x 720mm 가
가 가 가 가
가 가 가

(brazing)

가 가 가 (defect) 가 / 가 가

() 가 O () ,

[]

, / .

가

가

가

가

가

가

가

()

가

가

가

가

가

(57)

1.

1

가 ,

가

2.

1 , 가 , 가

3.

1 ,
1 1 2 가 , 1 2 , 가
1 1 2 , 1
2

4.

2 ,
2 1 2 가 , 1 2 , 가
1 1 2 , 1
1 2

5.

3 , 2 .

6.

4 , 2 .

7.

3 , .

8.

4 , .

9.

3 , 1 2 .

10.

4 , 1 2

11.

9 , 1 2
가

12.

10 , 1 2
가

13.

1 , 1 2 가 , 1 2 , 가
1 1 , 1 가
1 2 , 2 , 1 가
2 , .

14.

10 , : , 가
가 가 ; ,
가 가 ; .

15.

MPa ; 가 ; ; 2
885 가 ; 가 750 가 ; 1

16.

MPa ; 가 ; ; 2
가 가 750 가 ; 1

885 가 ;
3

17.

가 ; ; 100psi 가 ; 가 2 850 .

18.

가 ; ; 100psi 가 ; 가 2 850 .
3

19.

420 가 ; ; 가 ; 가 2
200psi

20.

420 가 ; ; 가 ; 가 2
200psi 3

21.

, , 가 , , 1 , 1

22.

21

23.

22

24.

23

25.

1

1

2

2

가

가

26.

25

27.

25

가

28.

29.

30.

24

31.

24

32.

1

33.

, 가

34.

33

35.

36.

35

3

2

3

2

2

37.

36 , 1 , 2
2 , 0

38.

36 , 1 , 2
2 ,

39.

1 , ,

가 ,

가 .

40.

39 , 가 ,

41.

39 , , 가 .

42.

가

가

10 ,

1

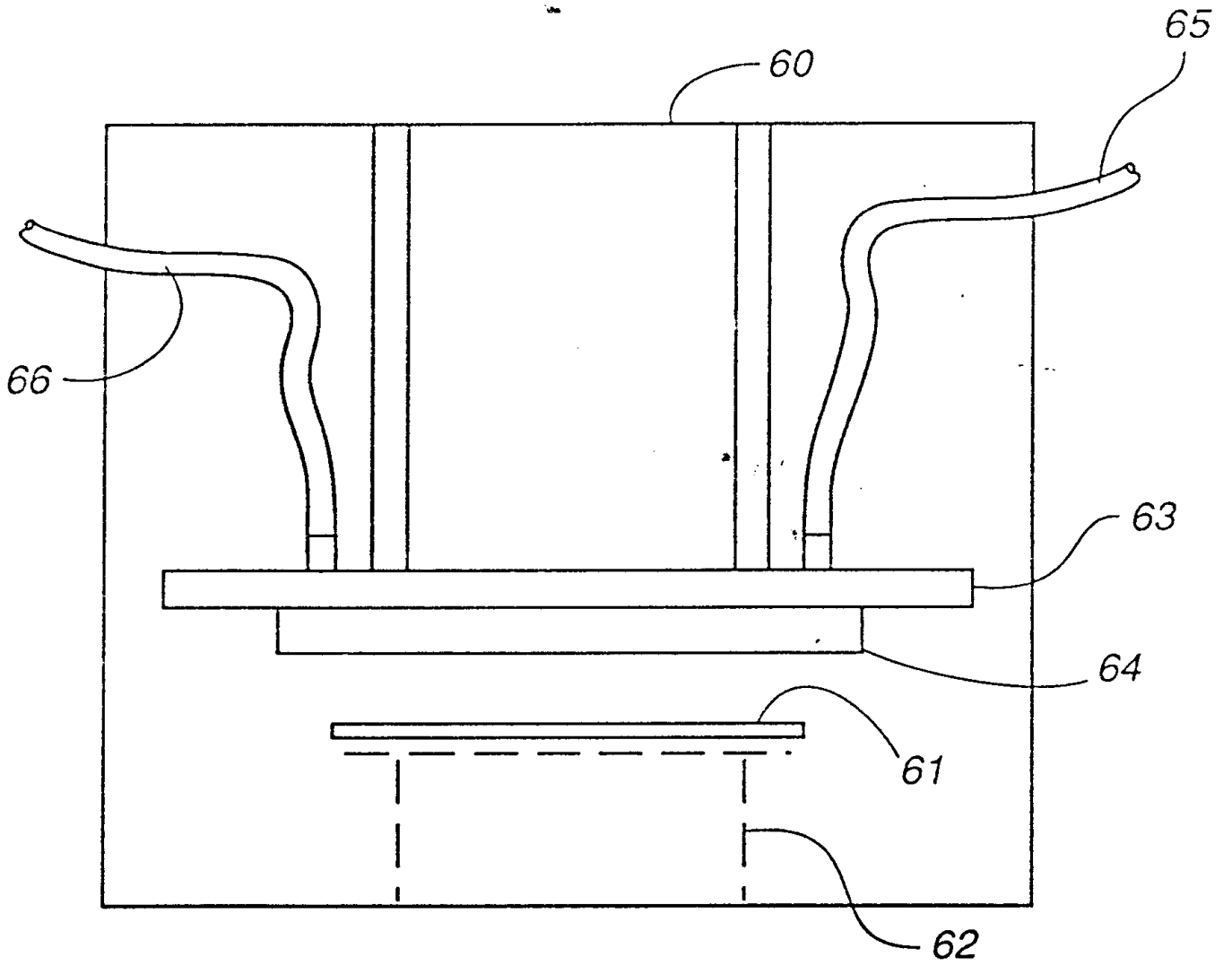

(PRIOR ART)

2

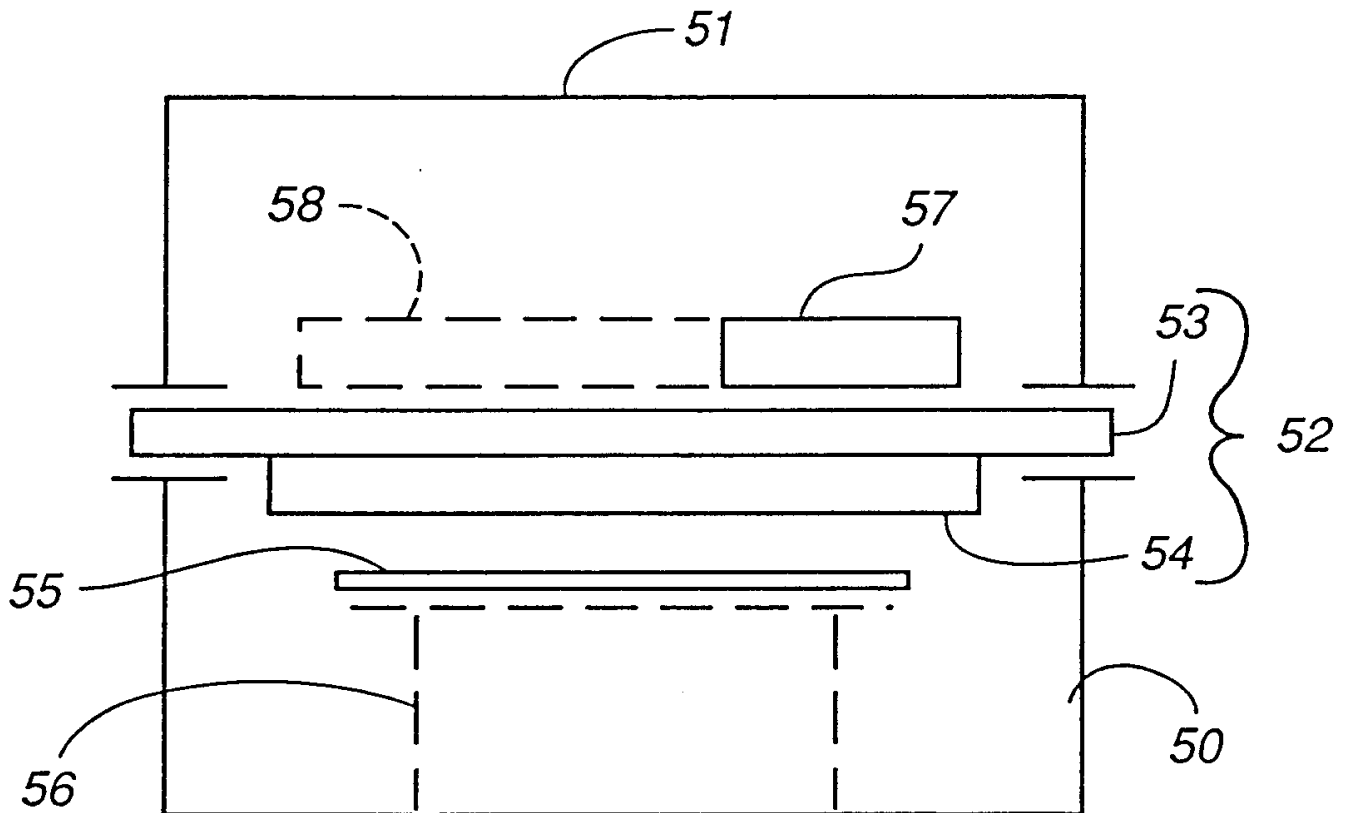

(PRIOR ART)

3

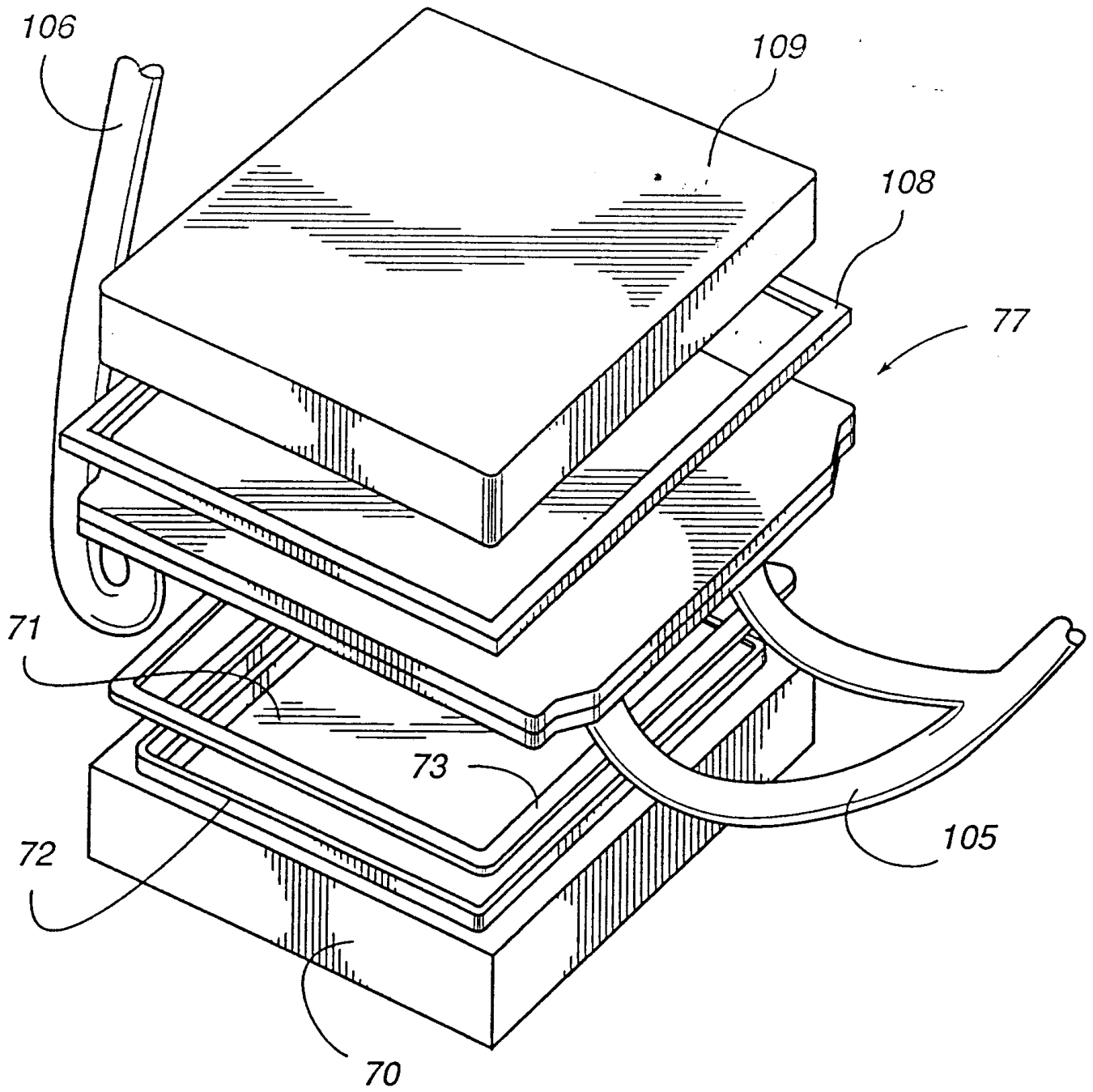

4

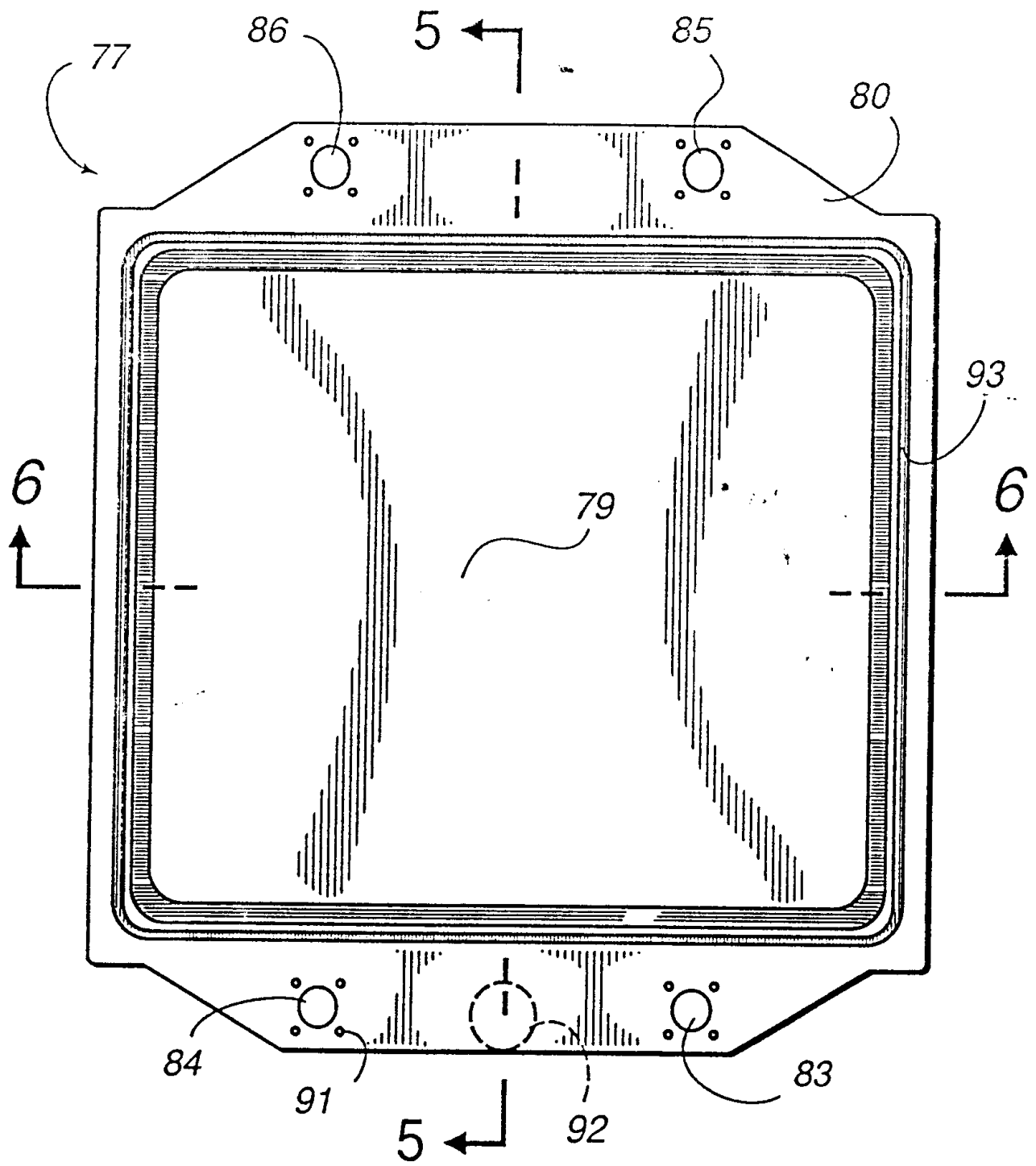

5

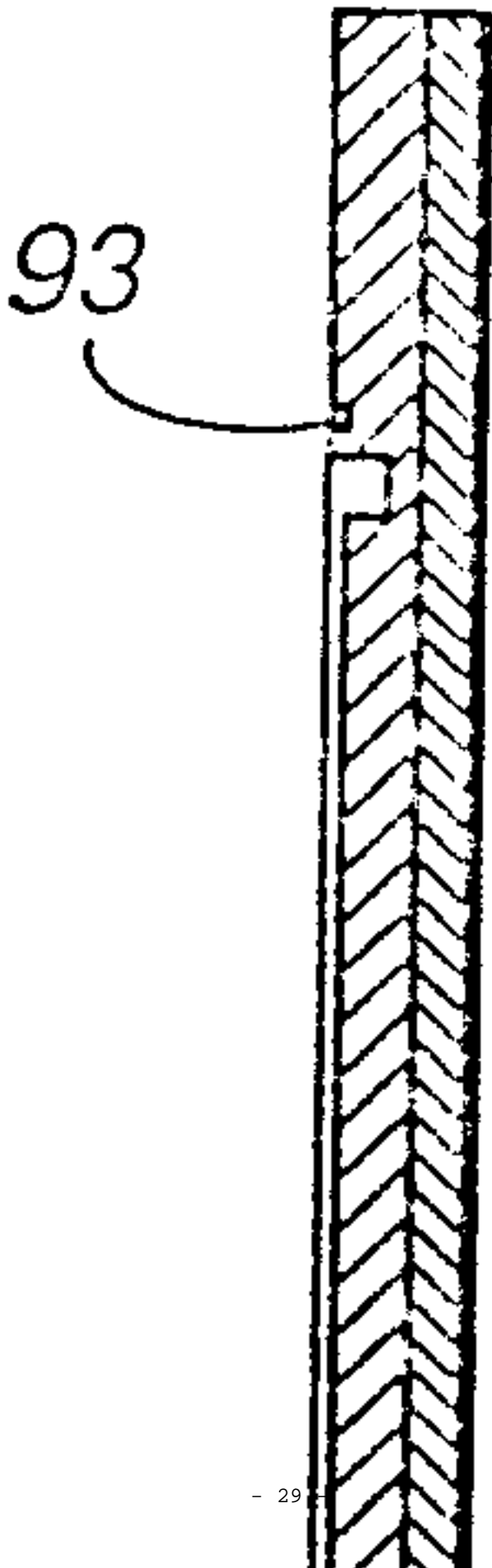

6

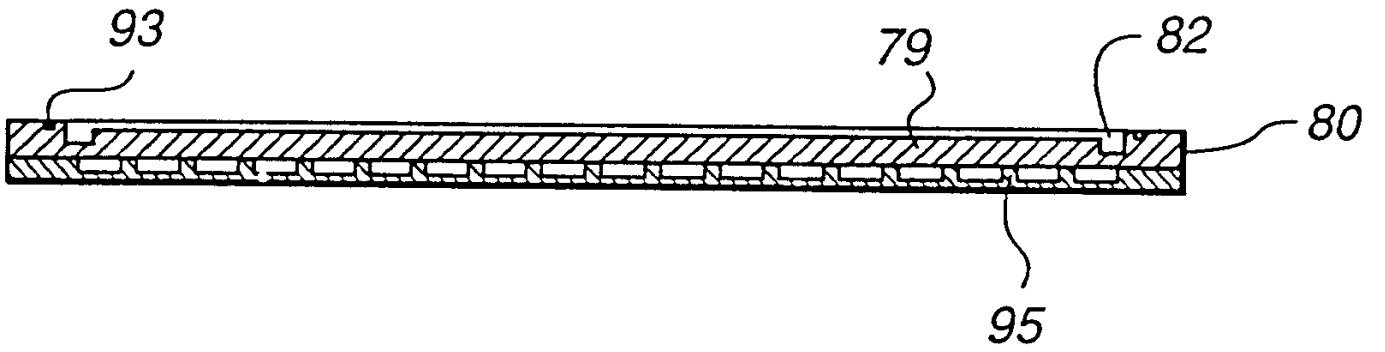

7

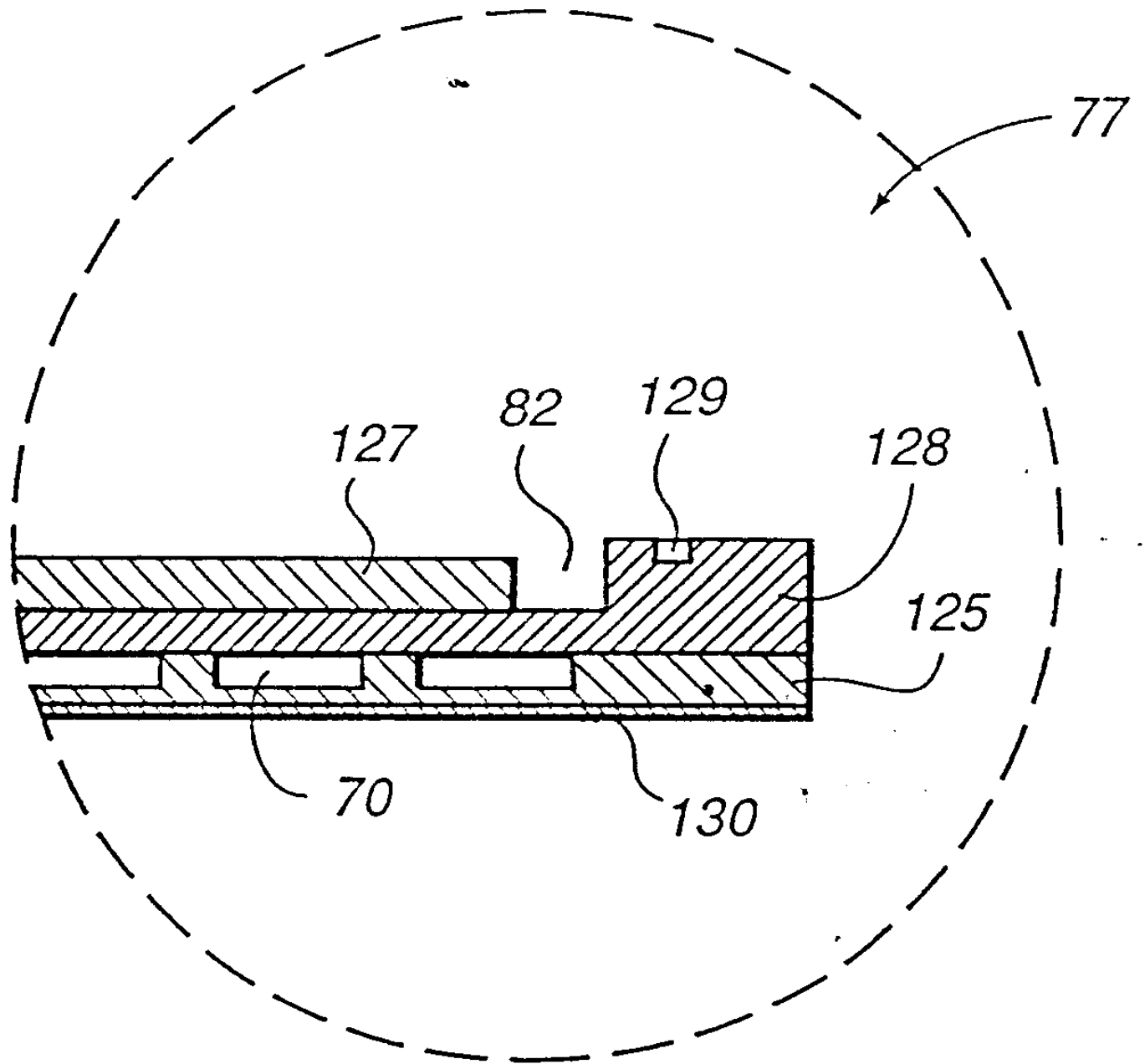

8

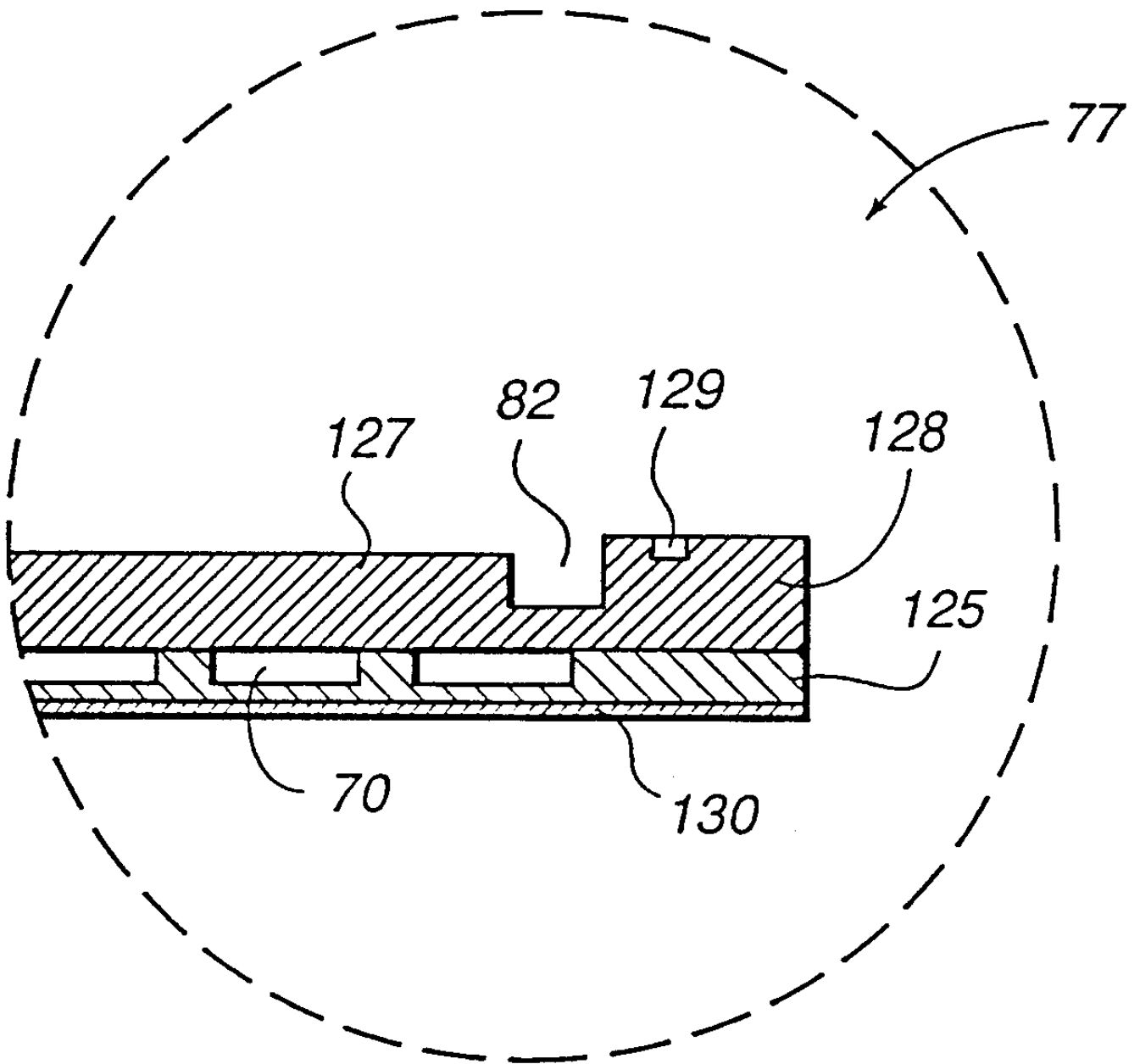

9

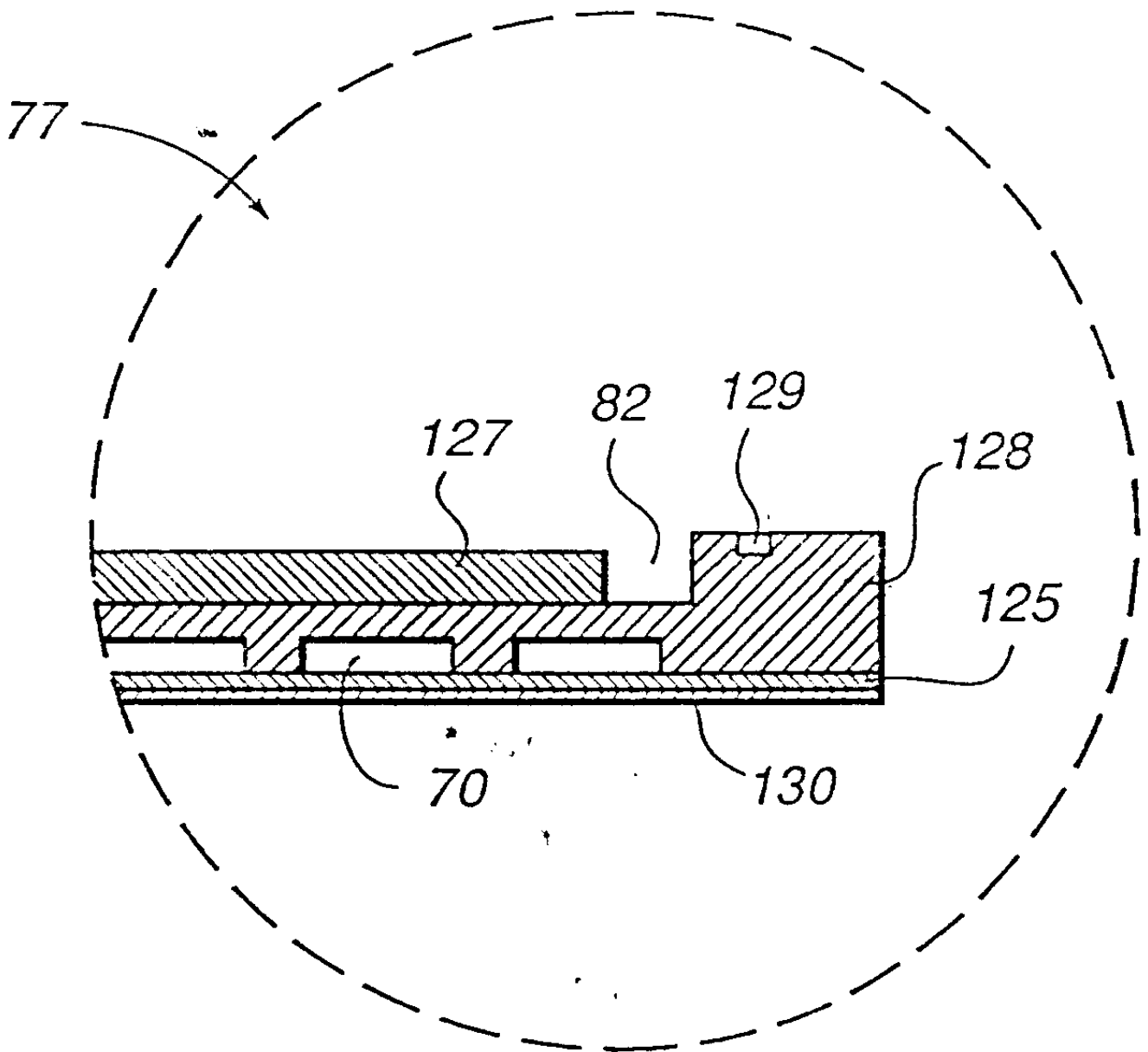

10

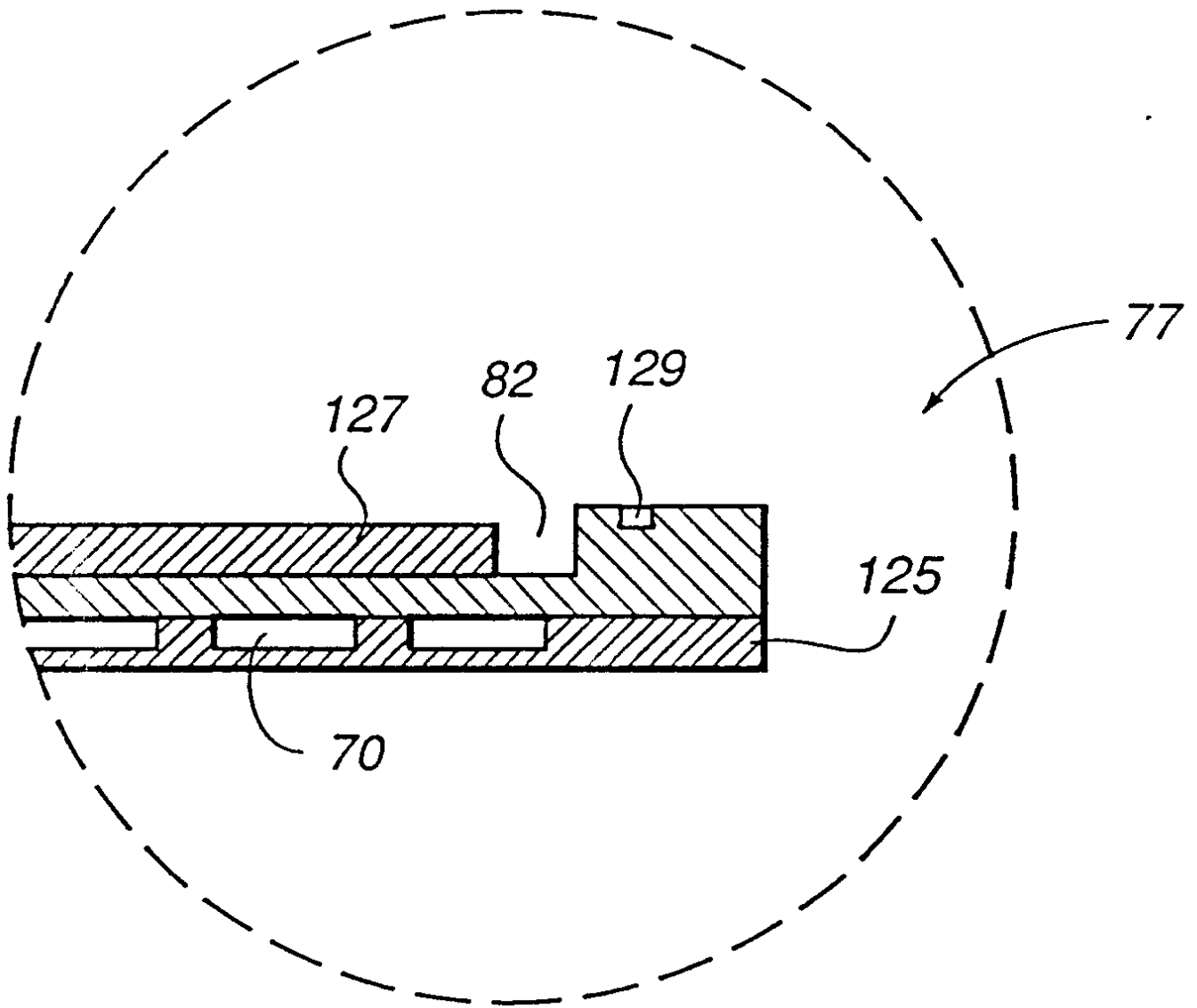

11

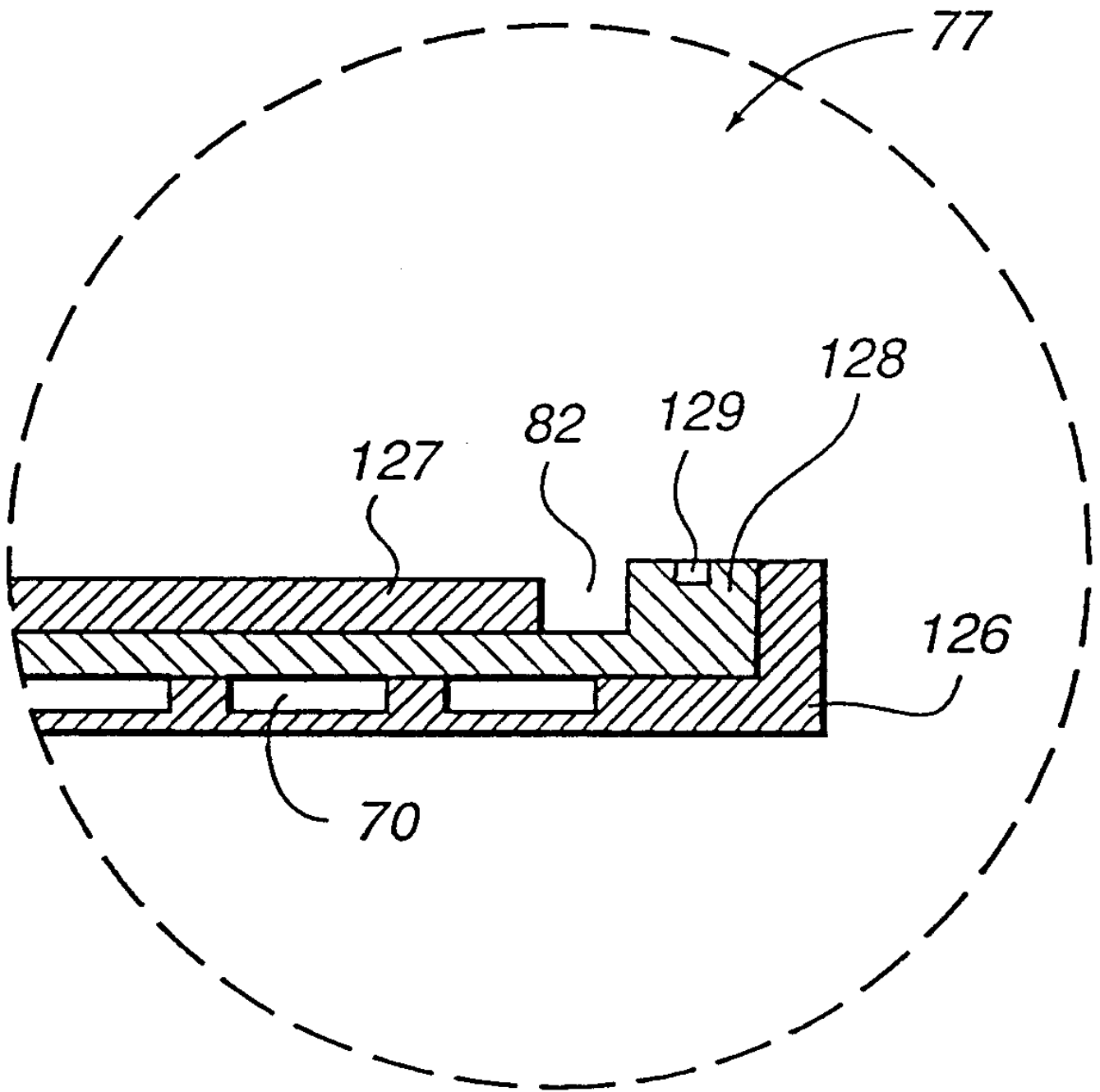

12

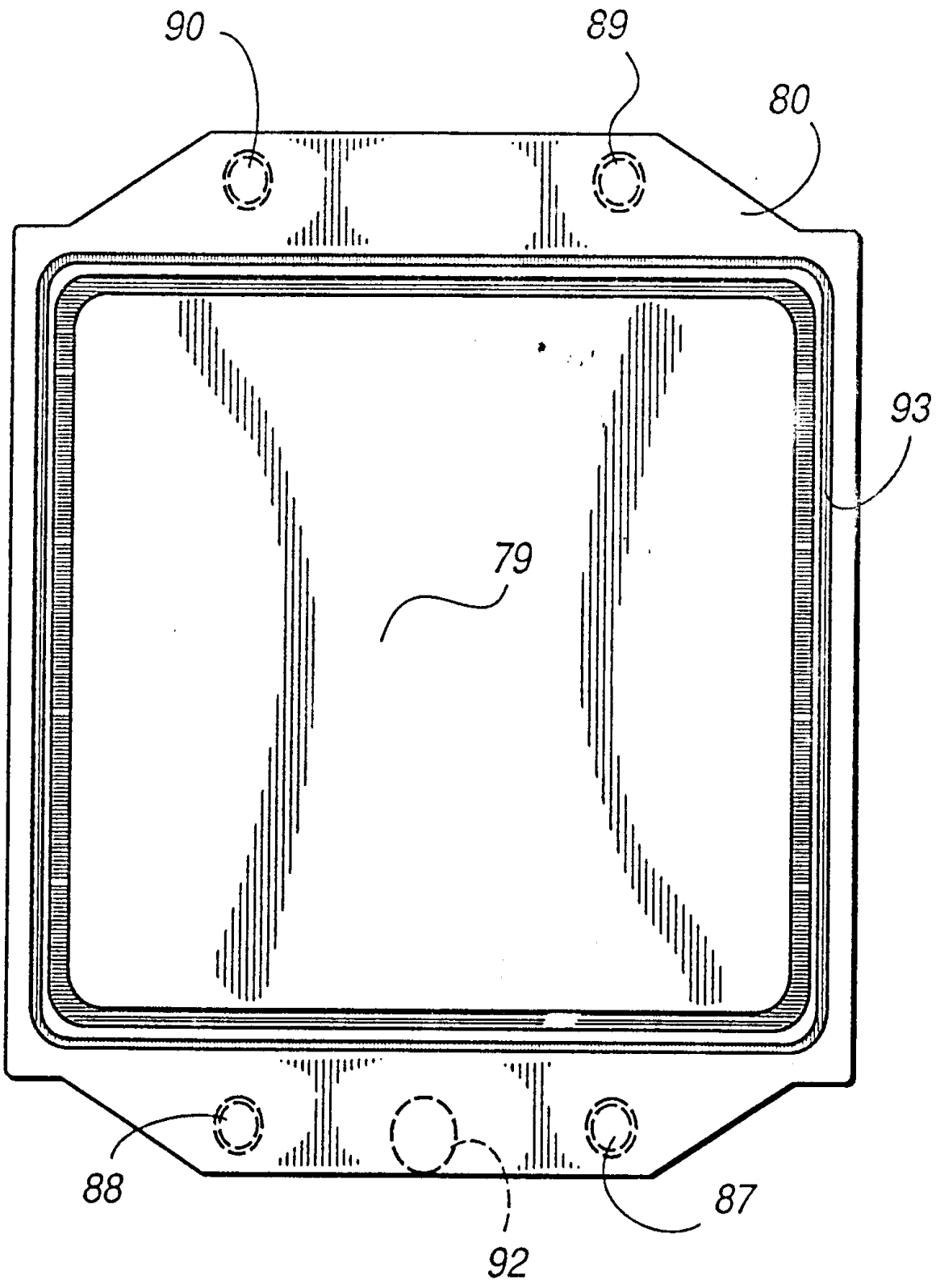

13

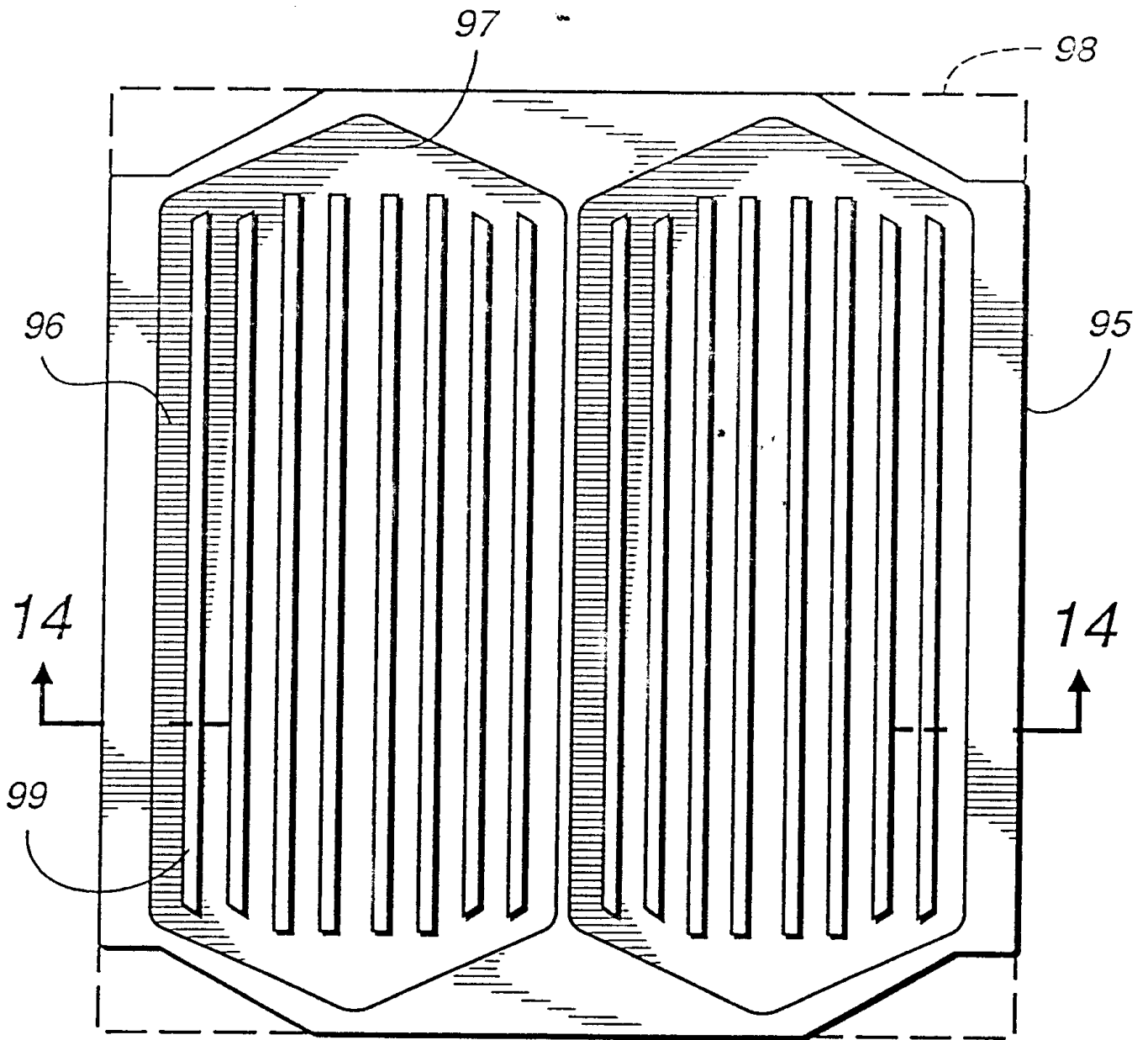

14

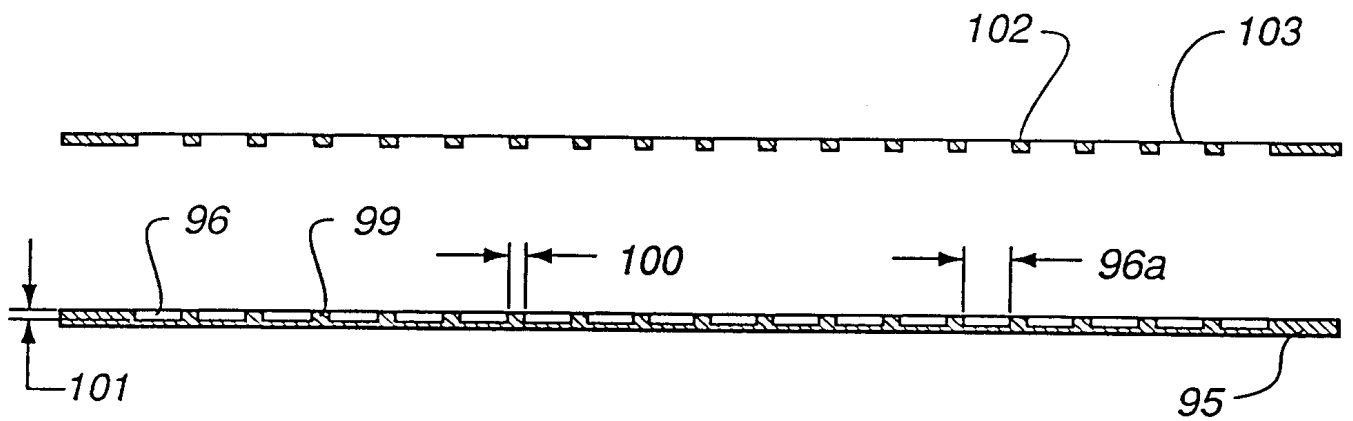

15

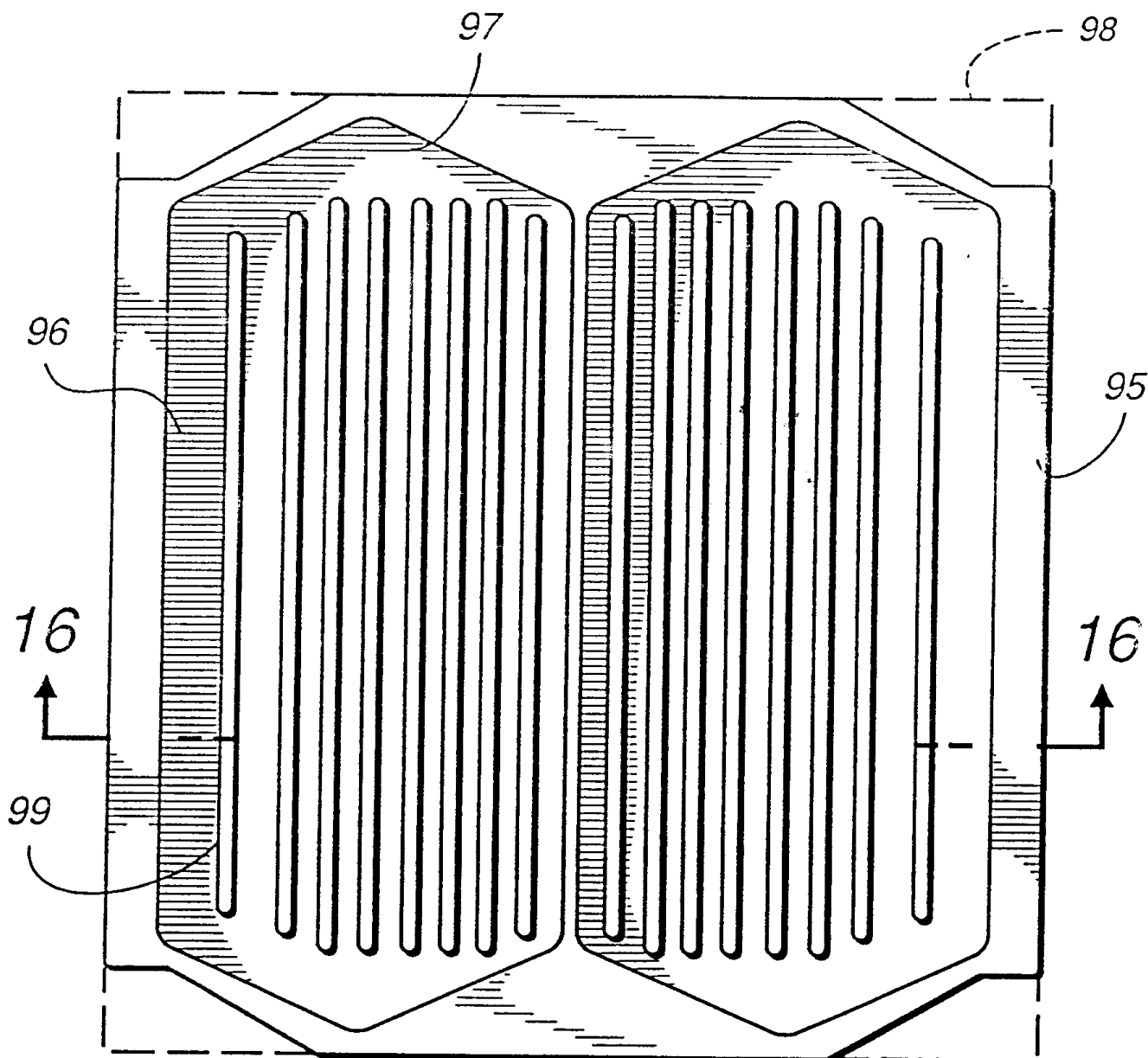

16

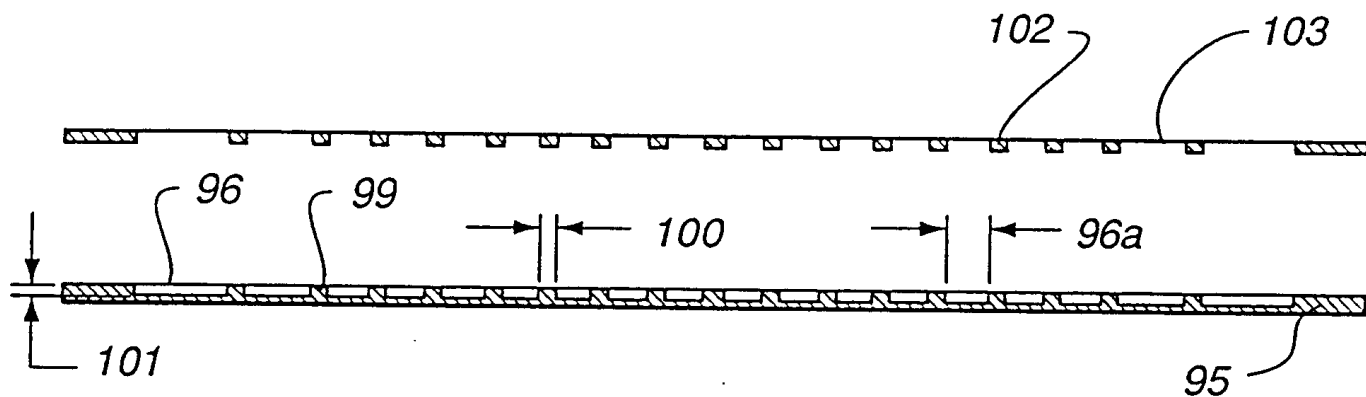

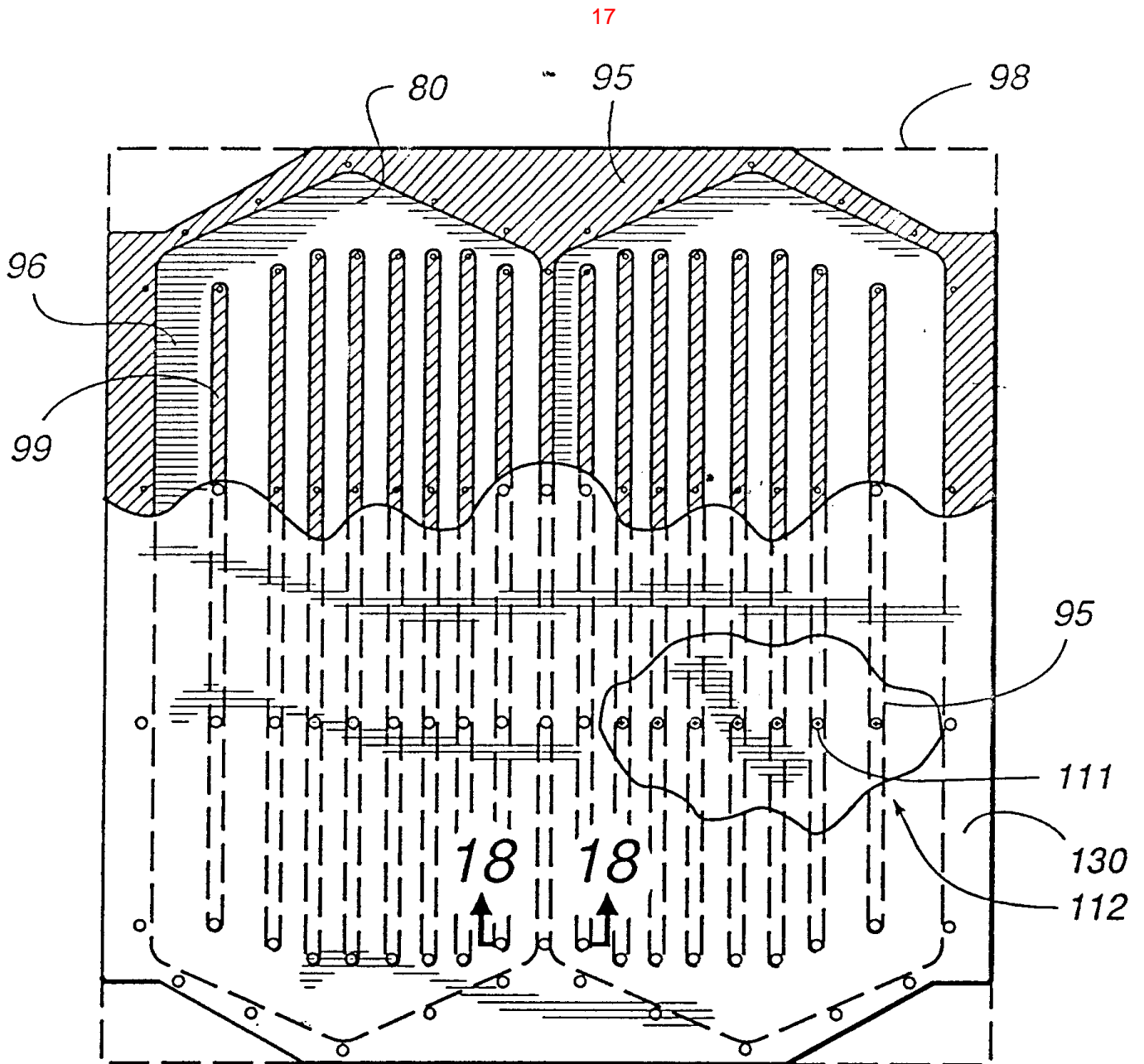

18

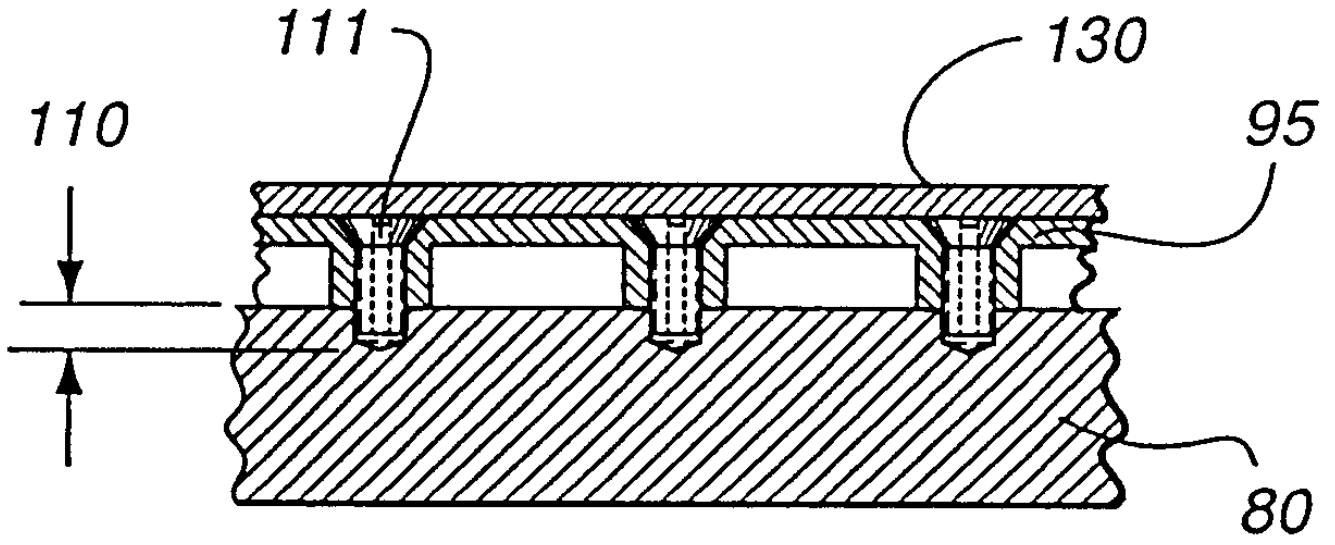

19

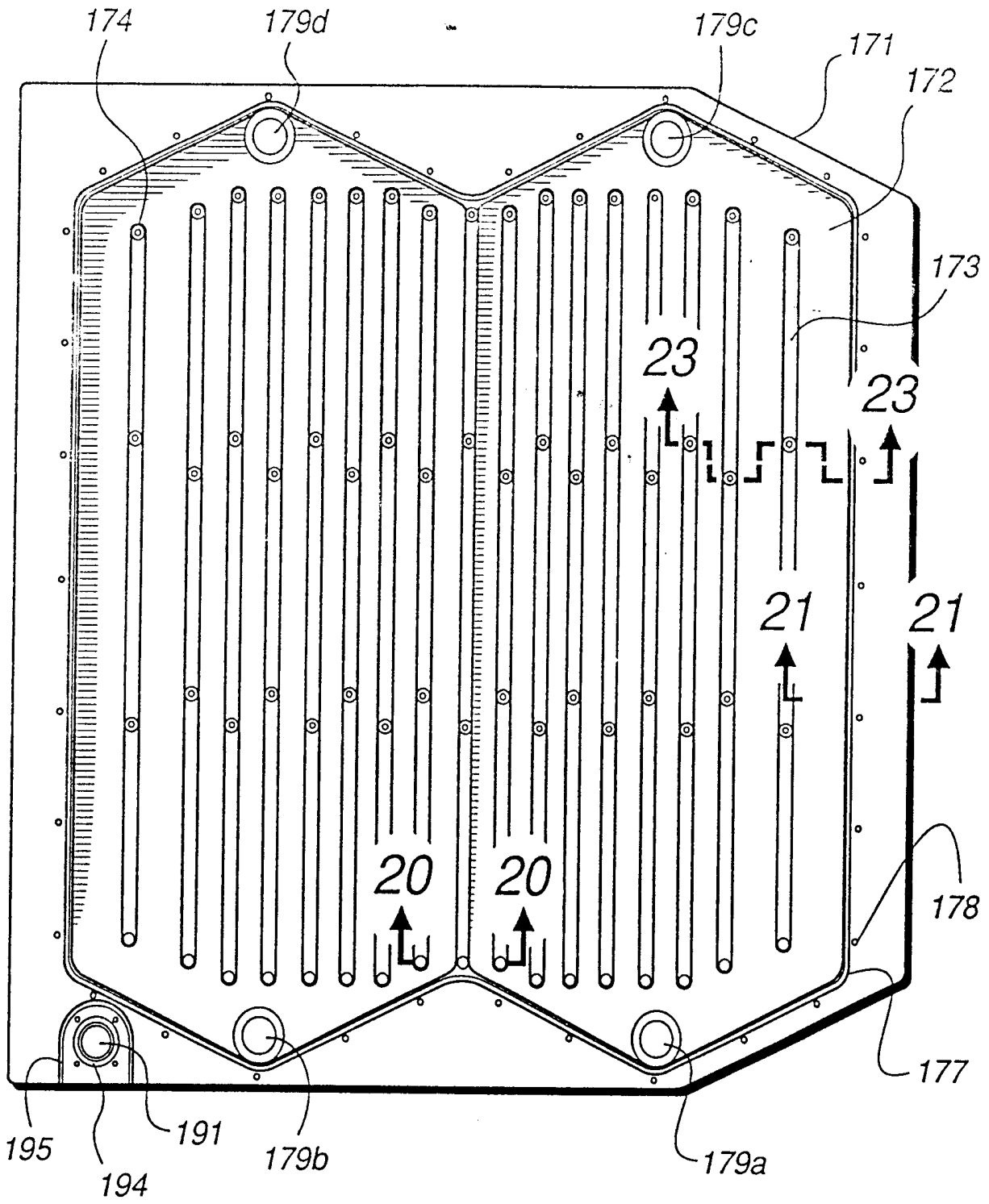

20

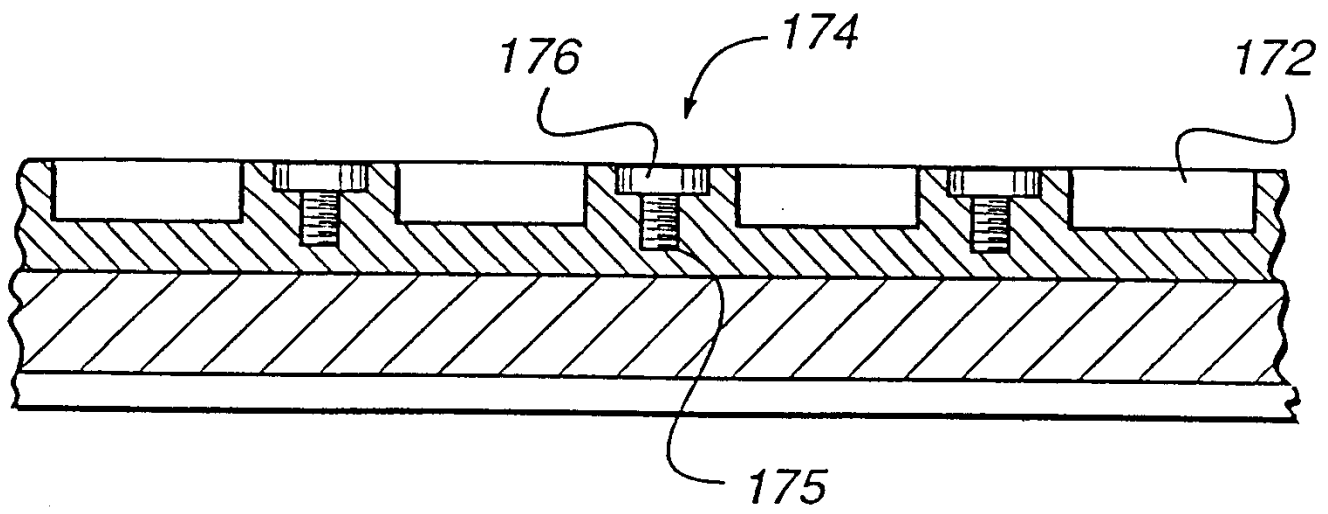

21

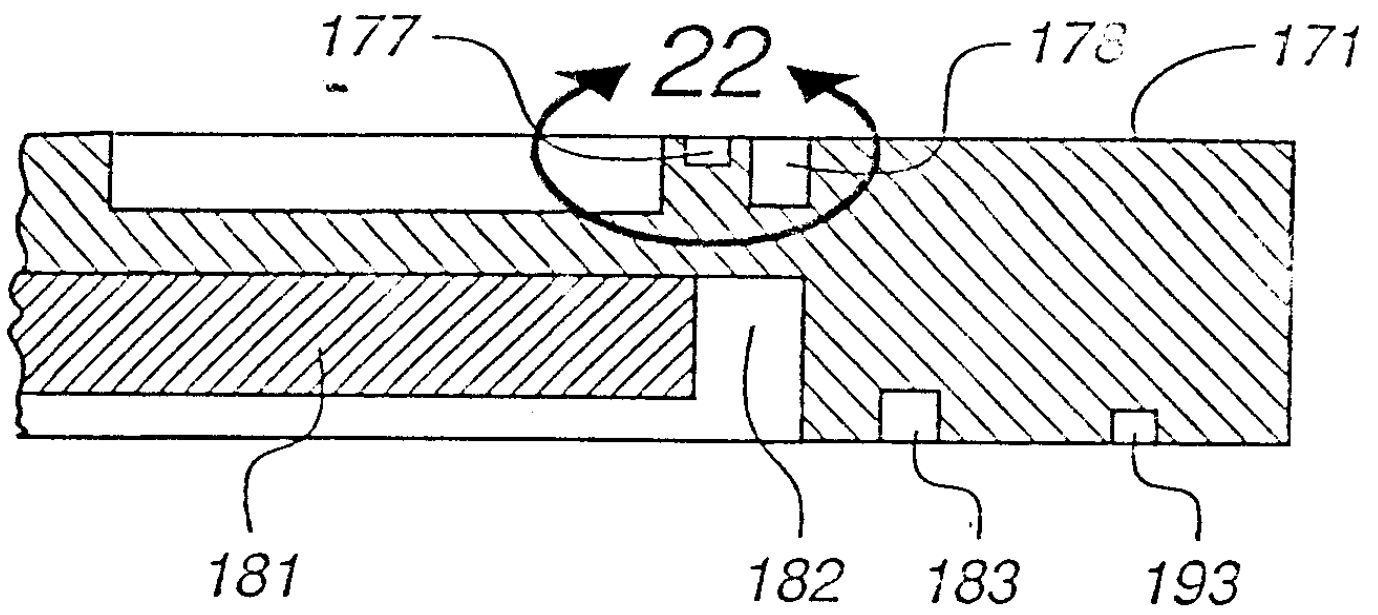

22

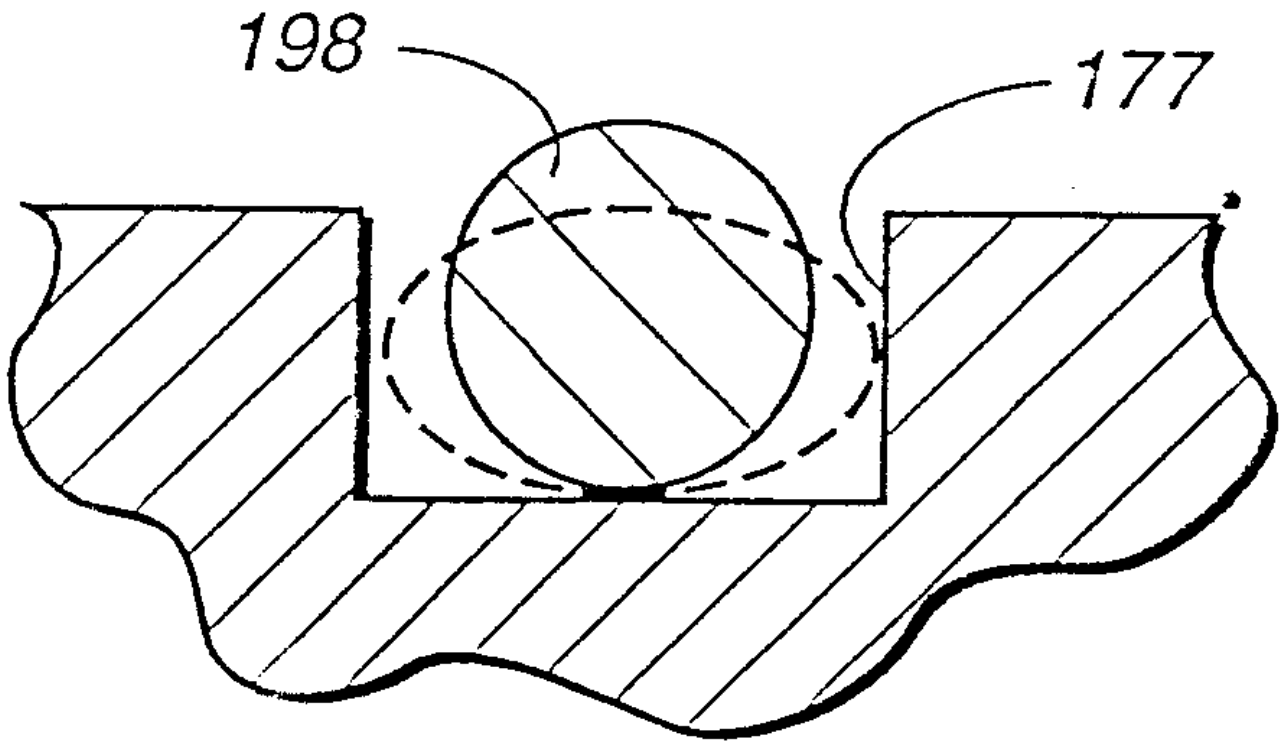

23

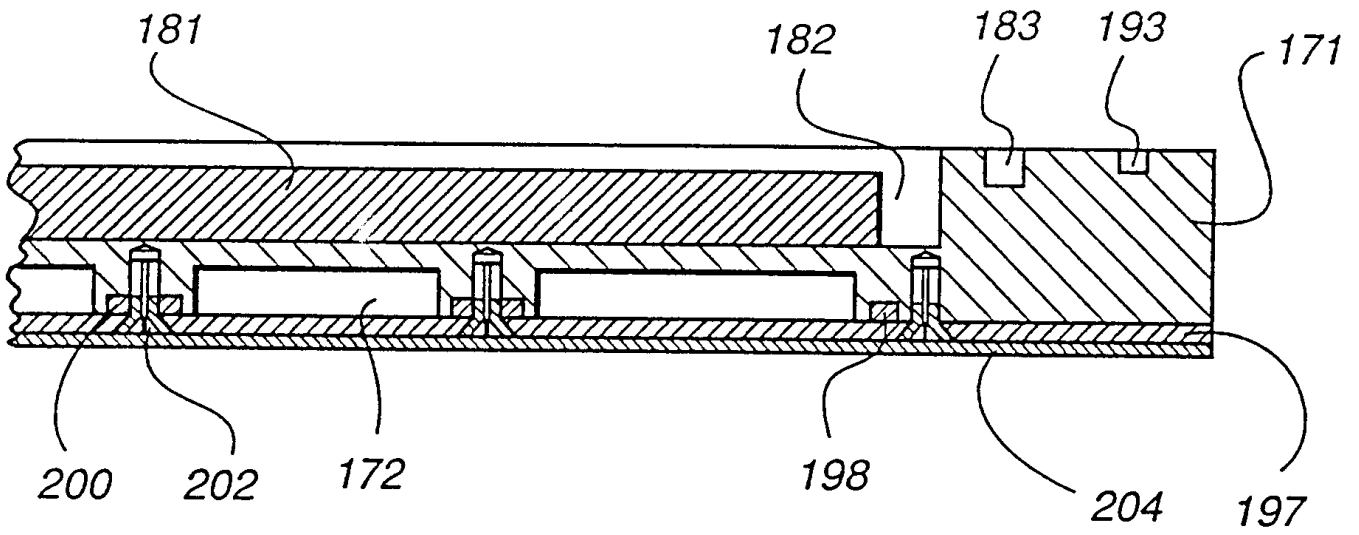

24

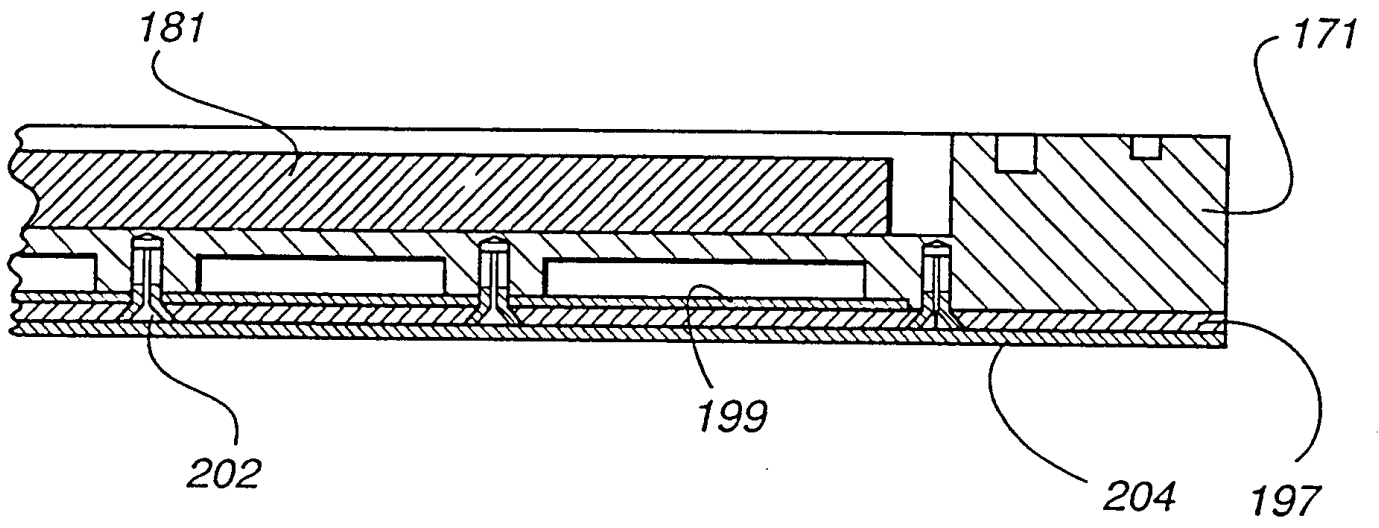



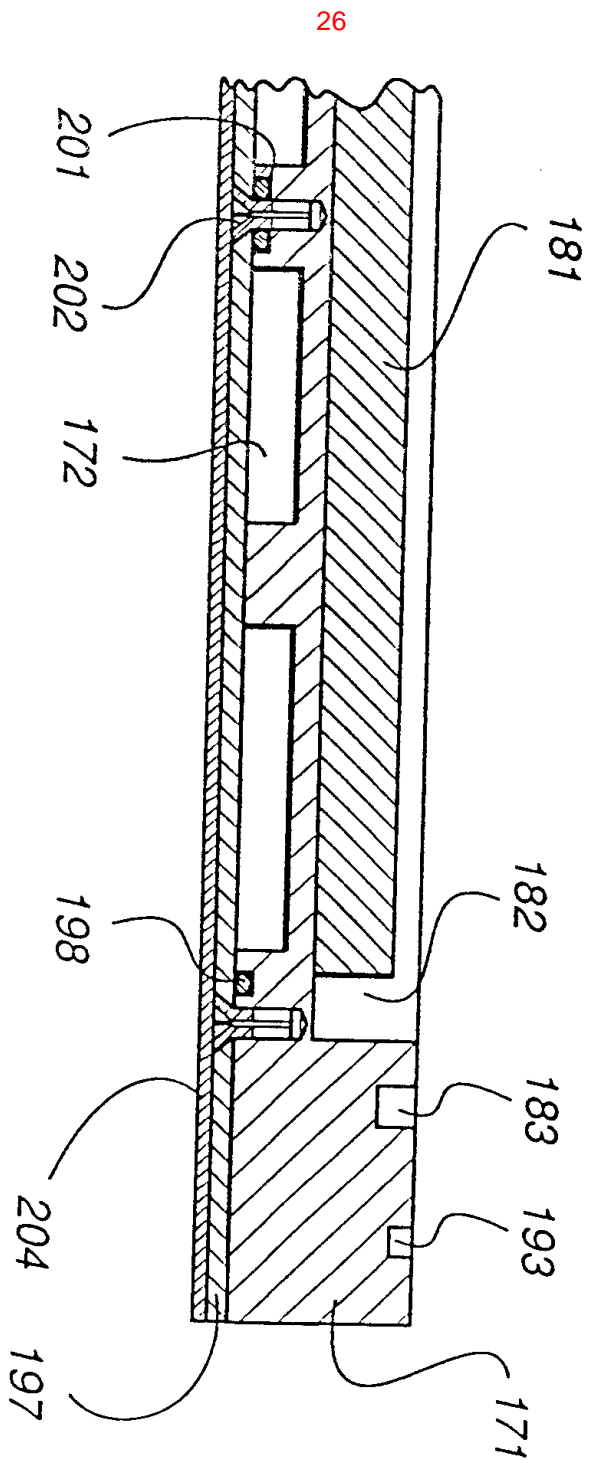

27

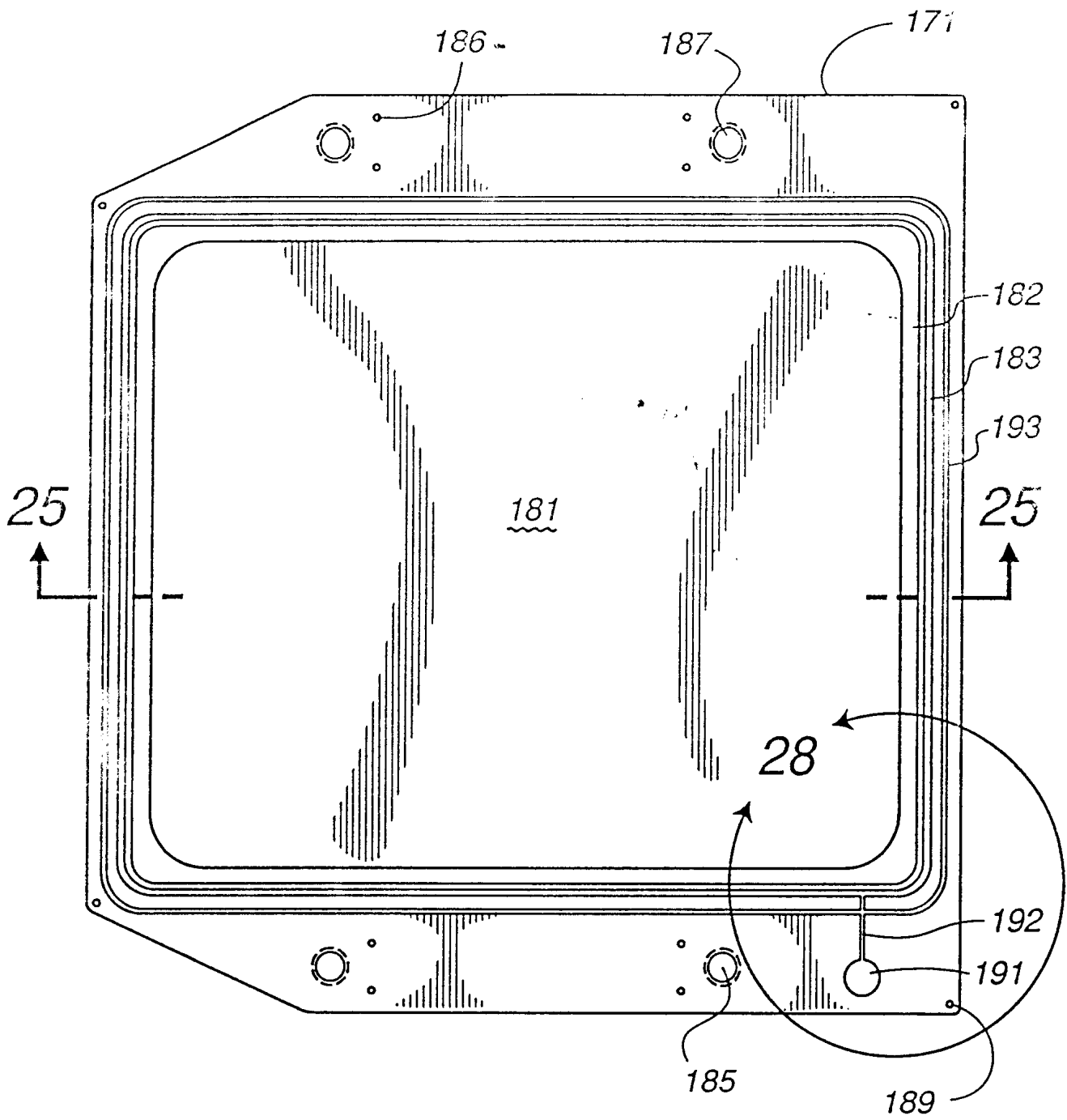

28

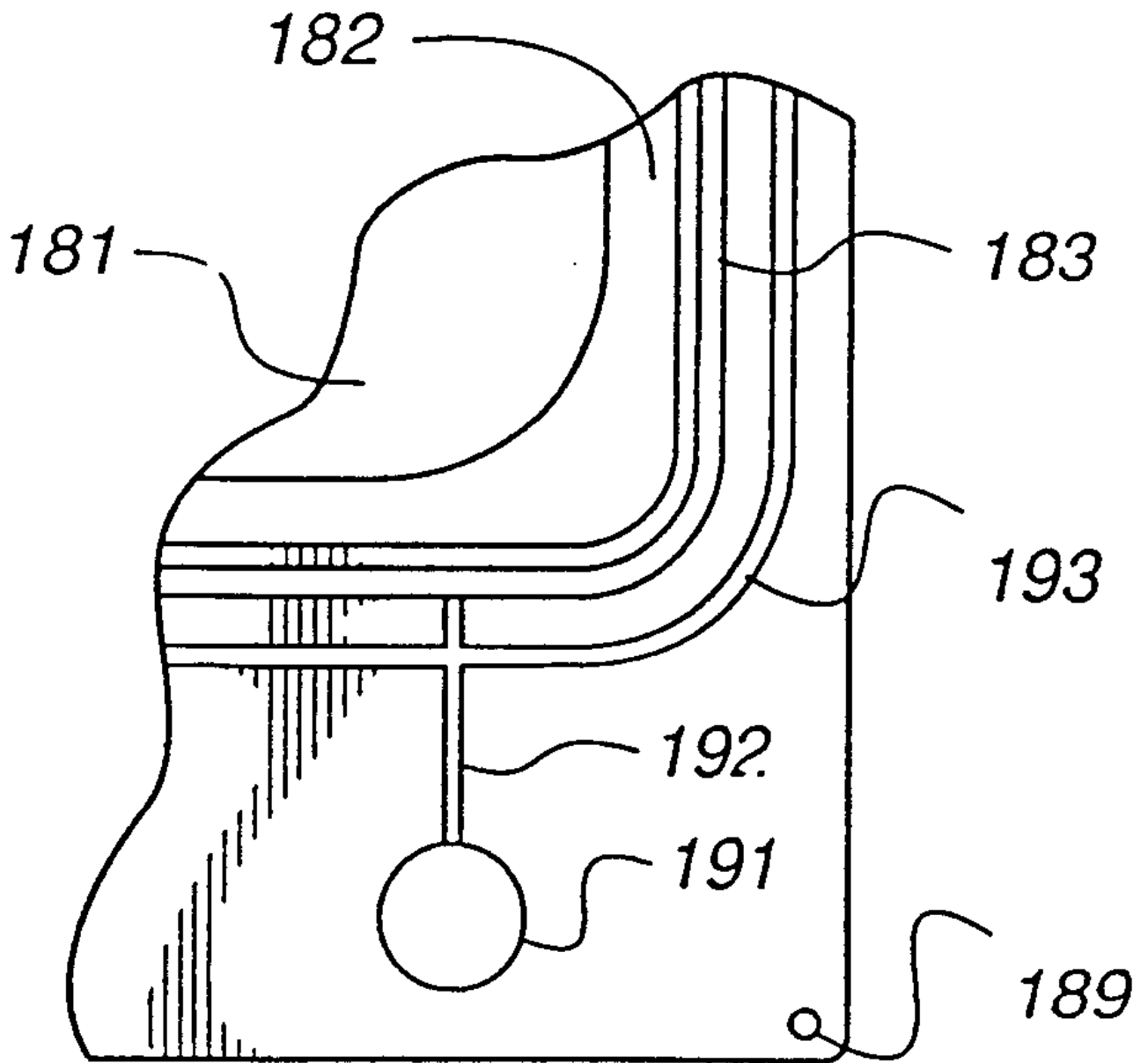

29

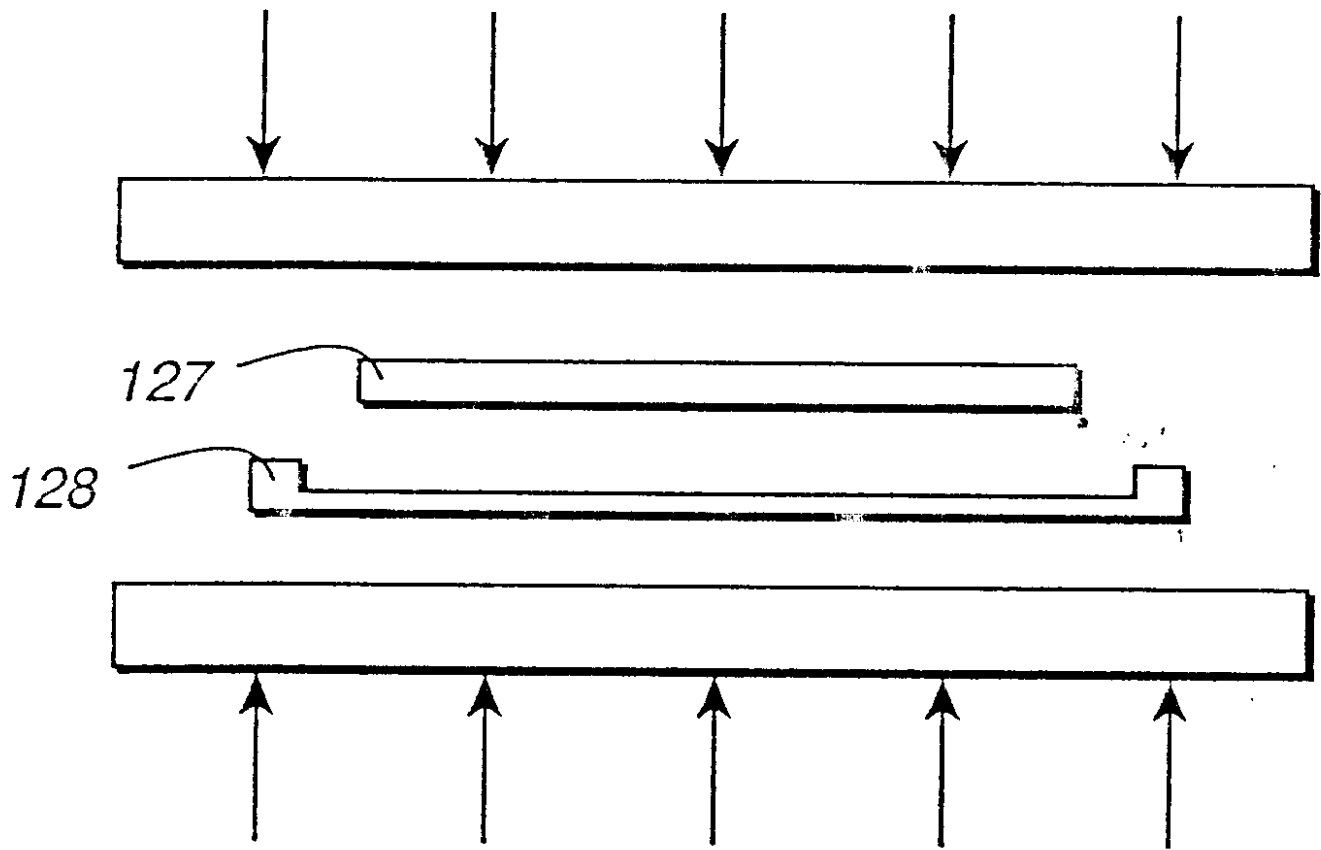

30

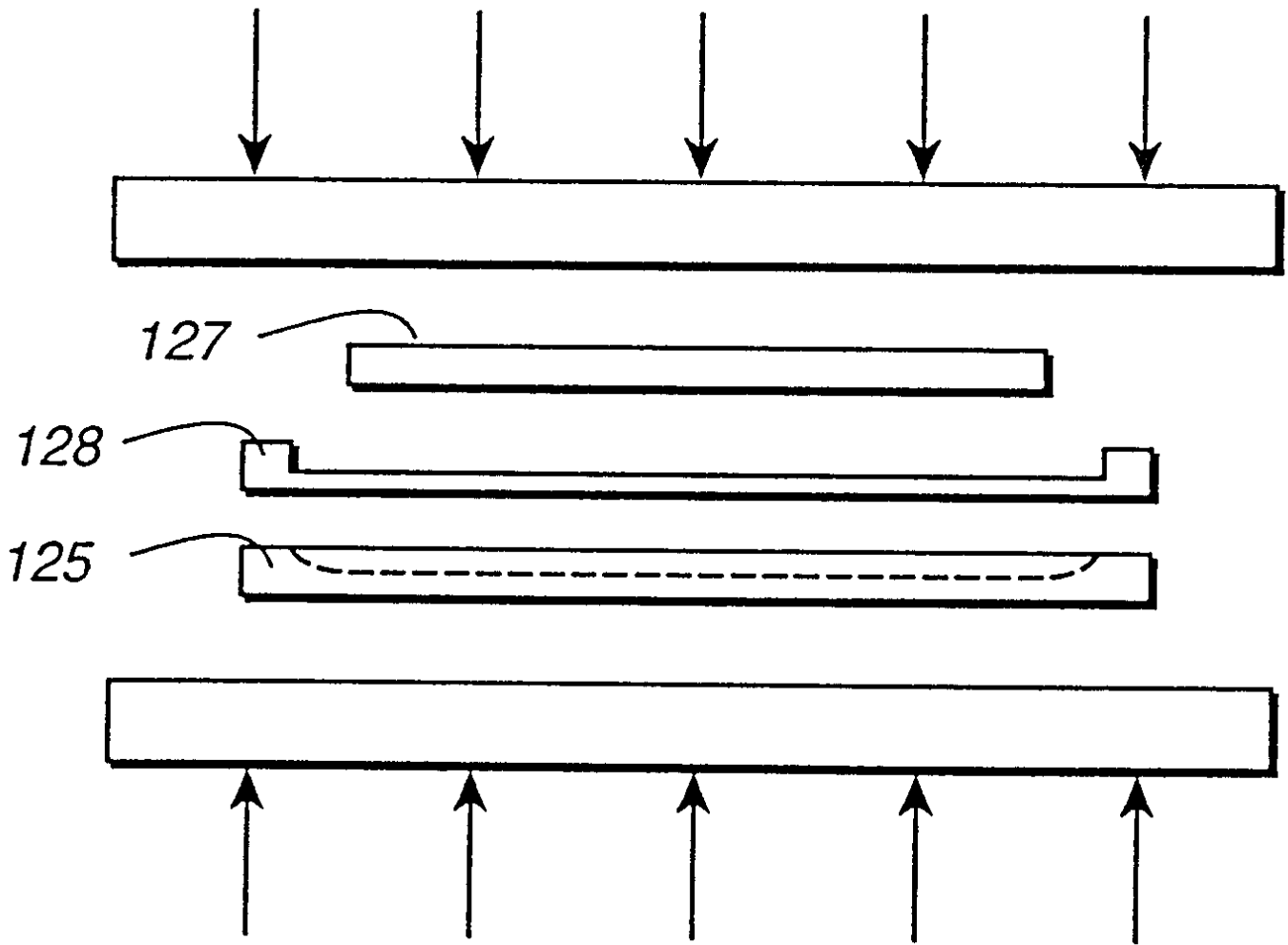

31

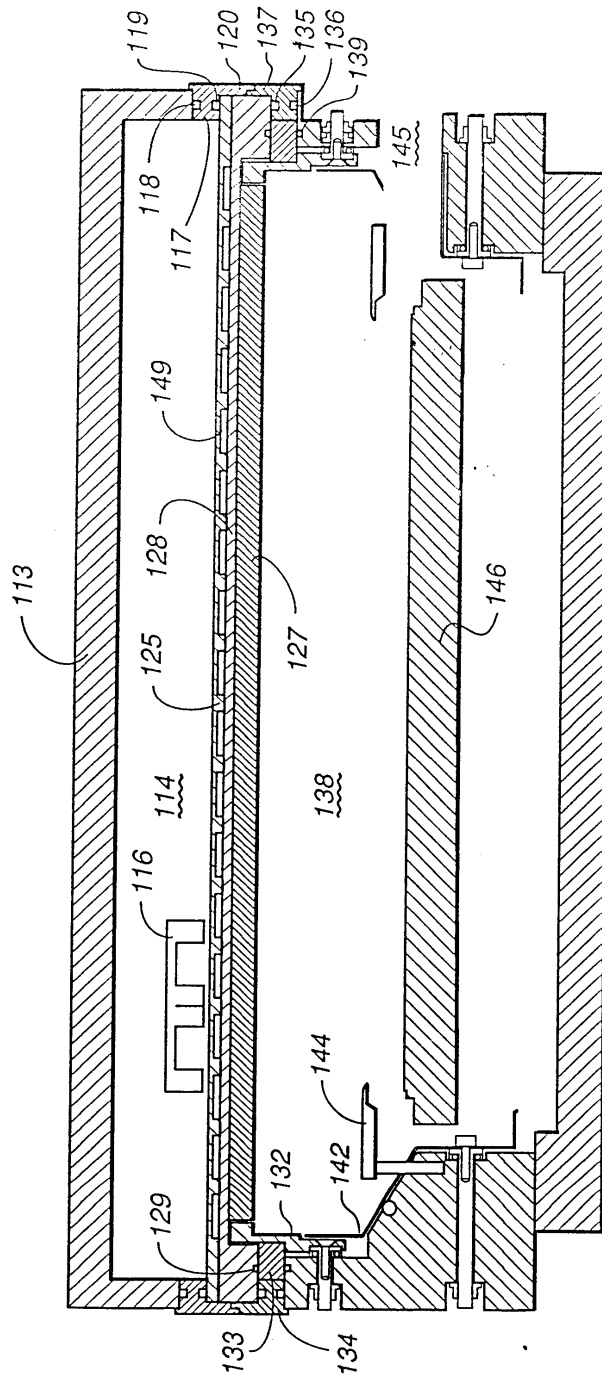

32

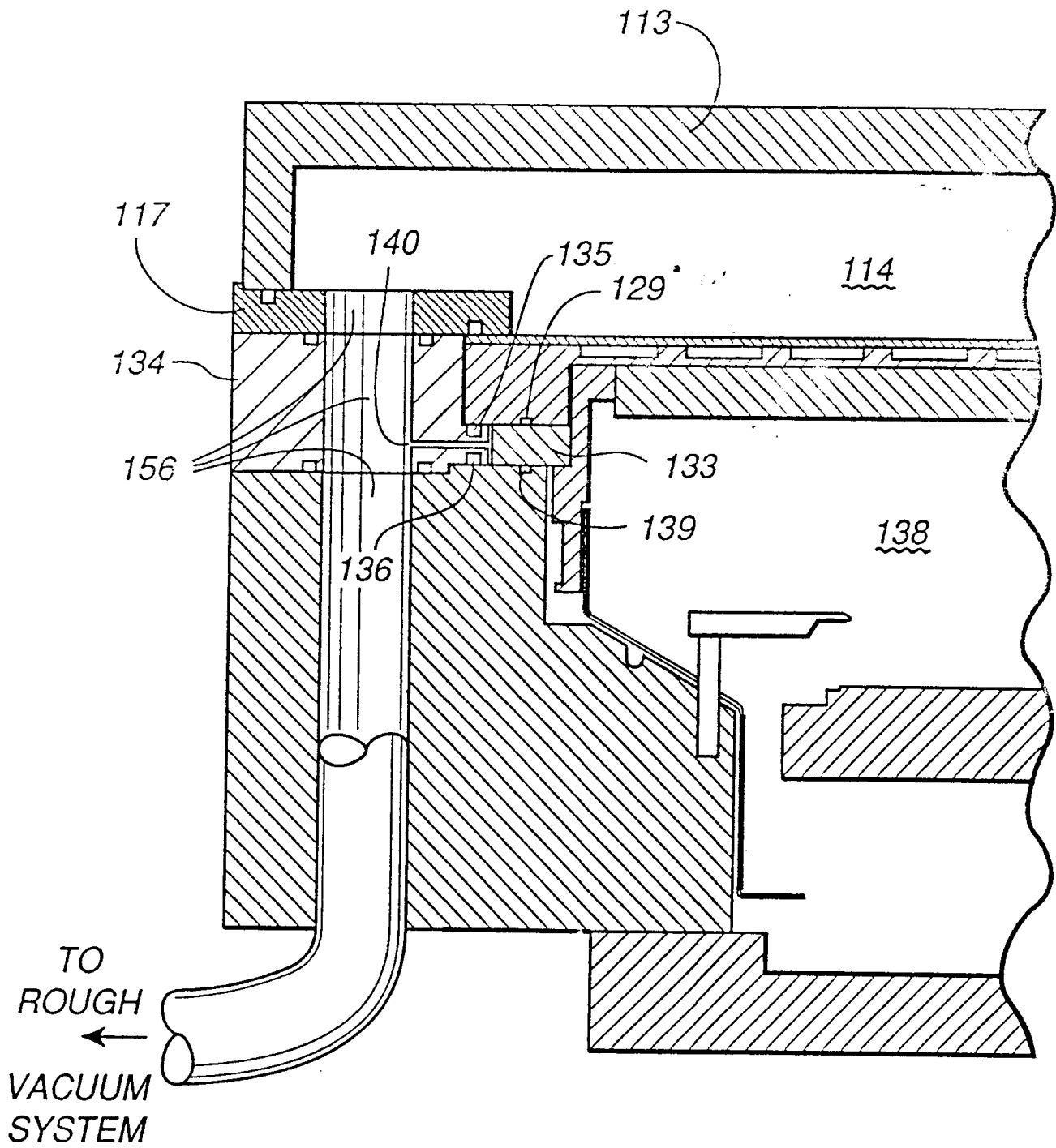

33

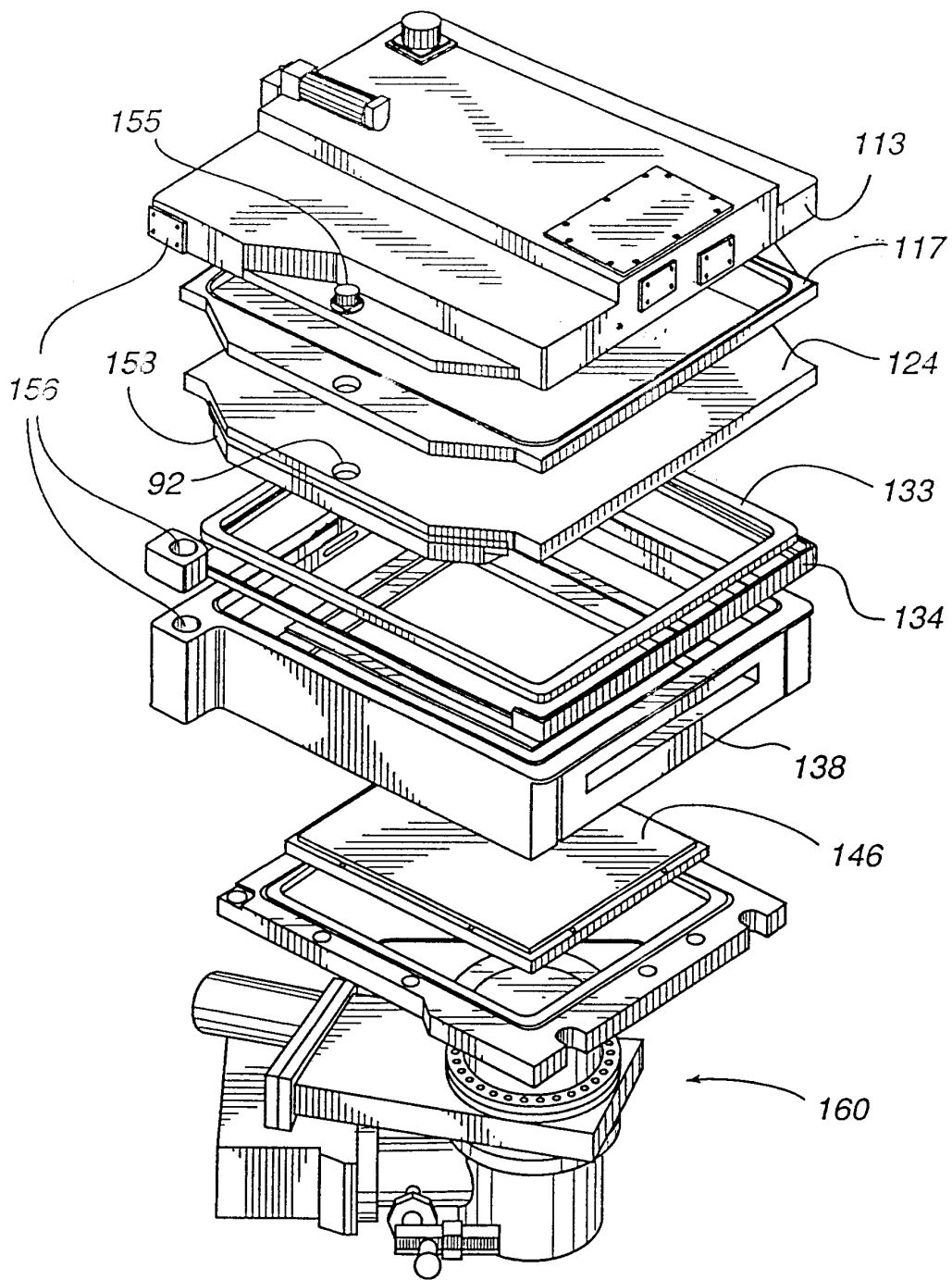

34

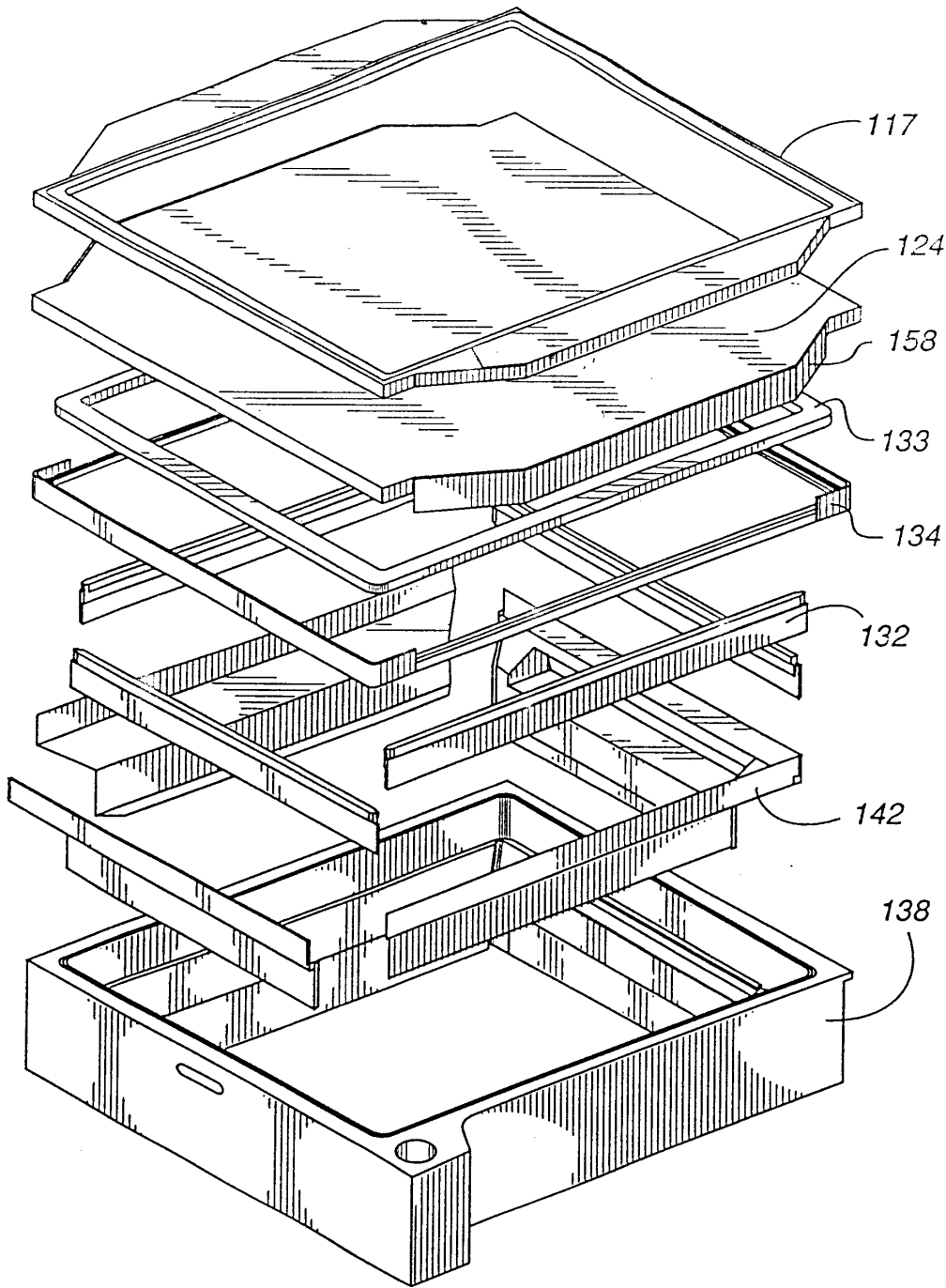

35

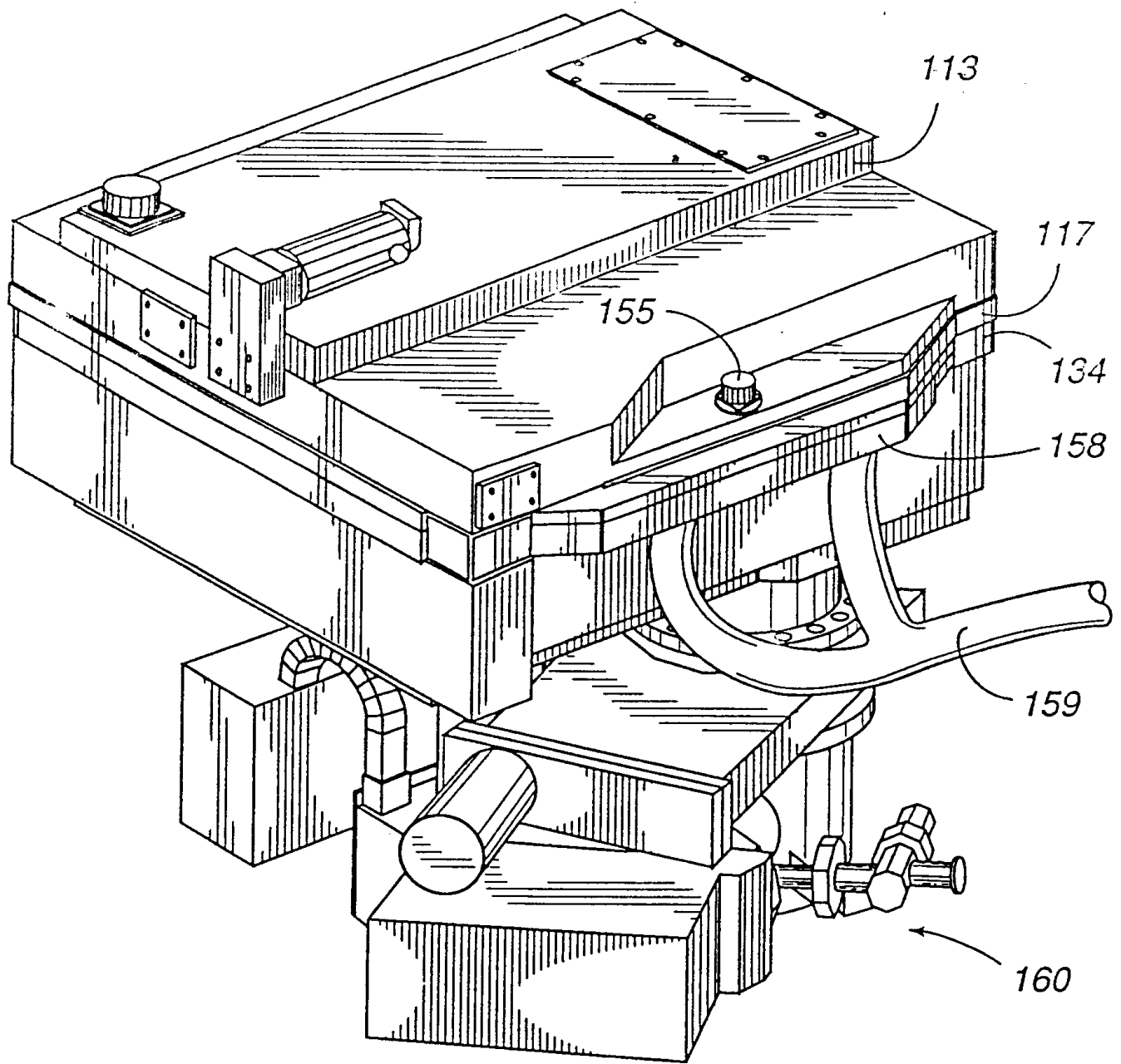

37

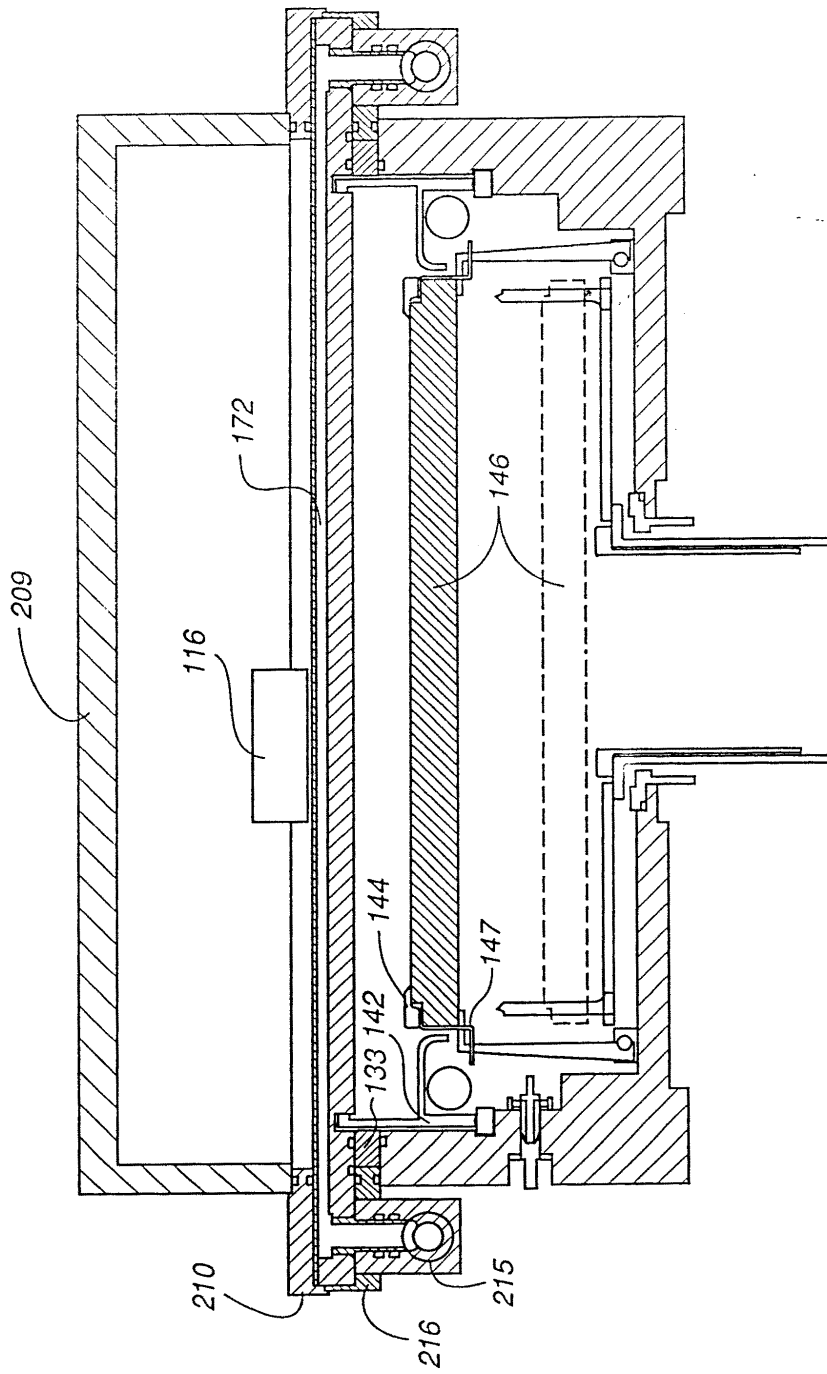

38

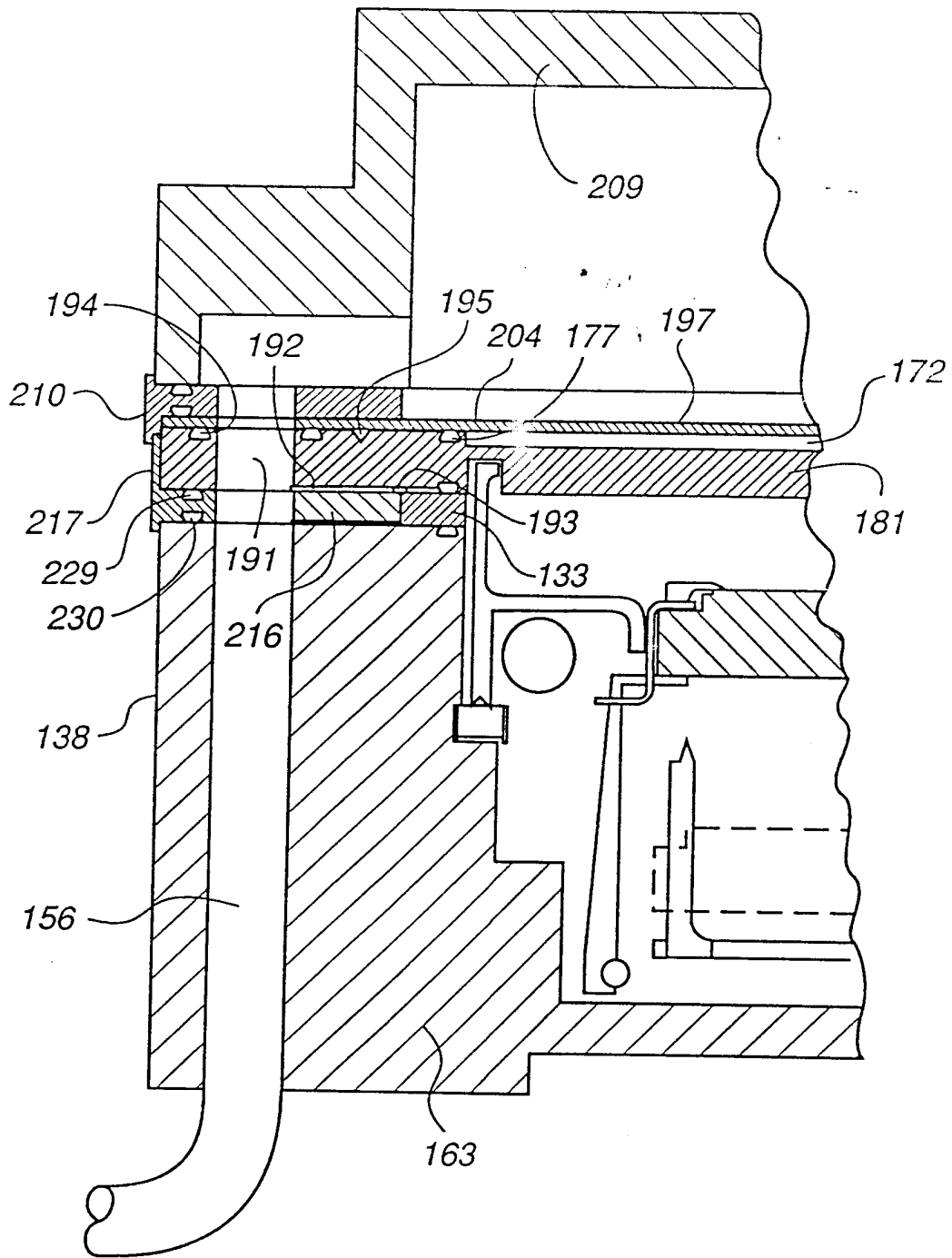

39

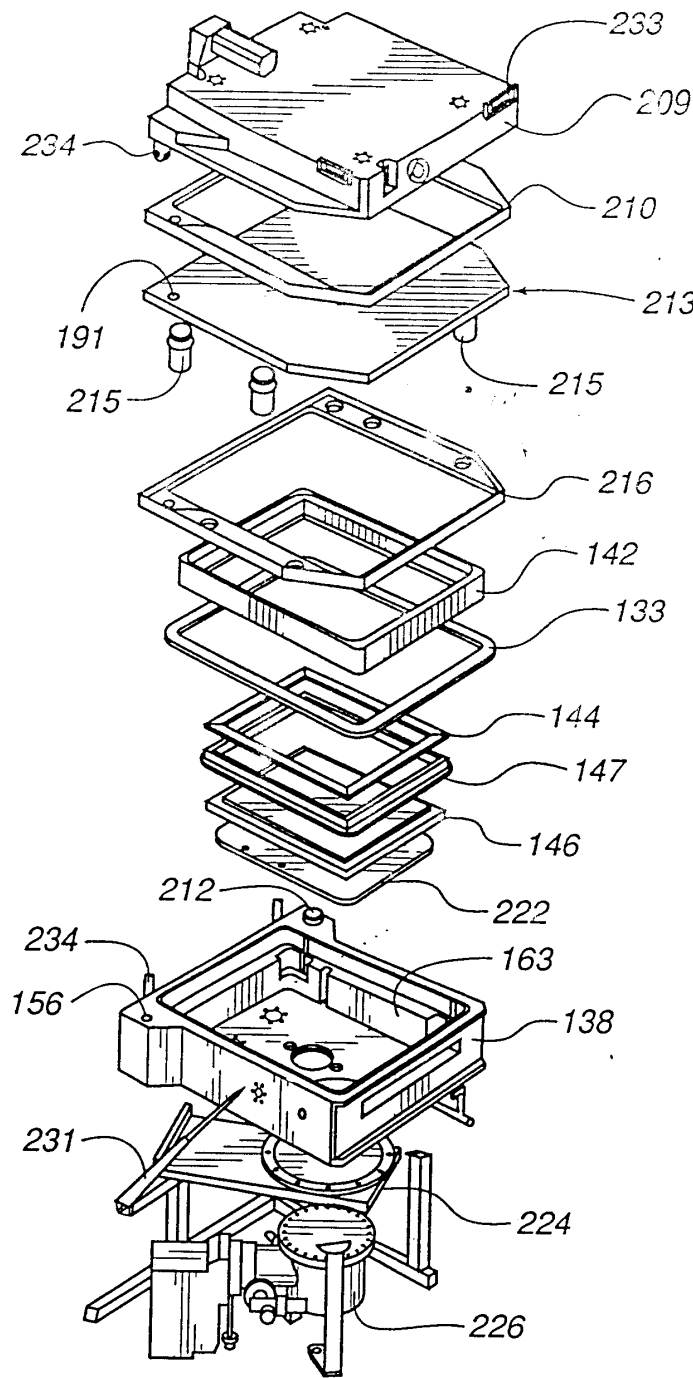

40

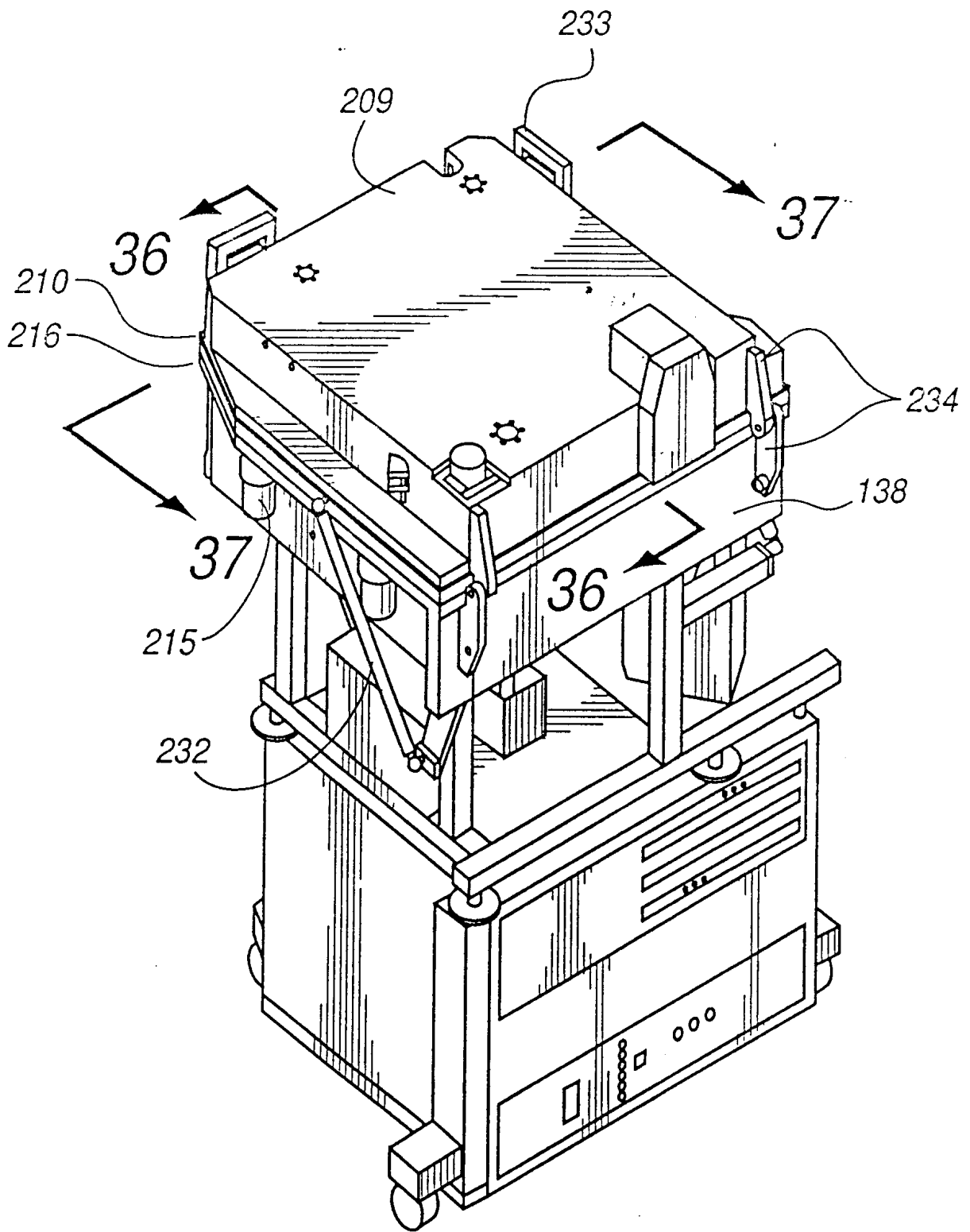

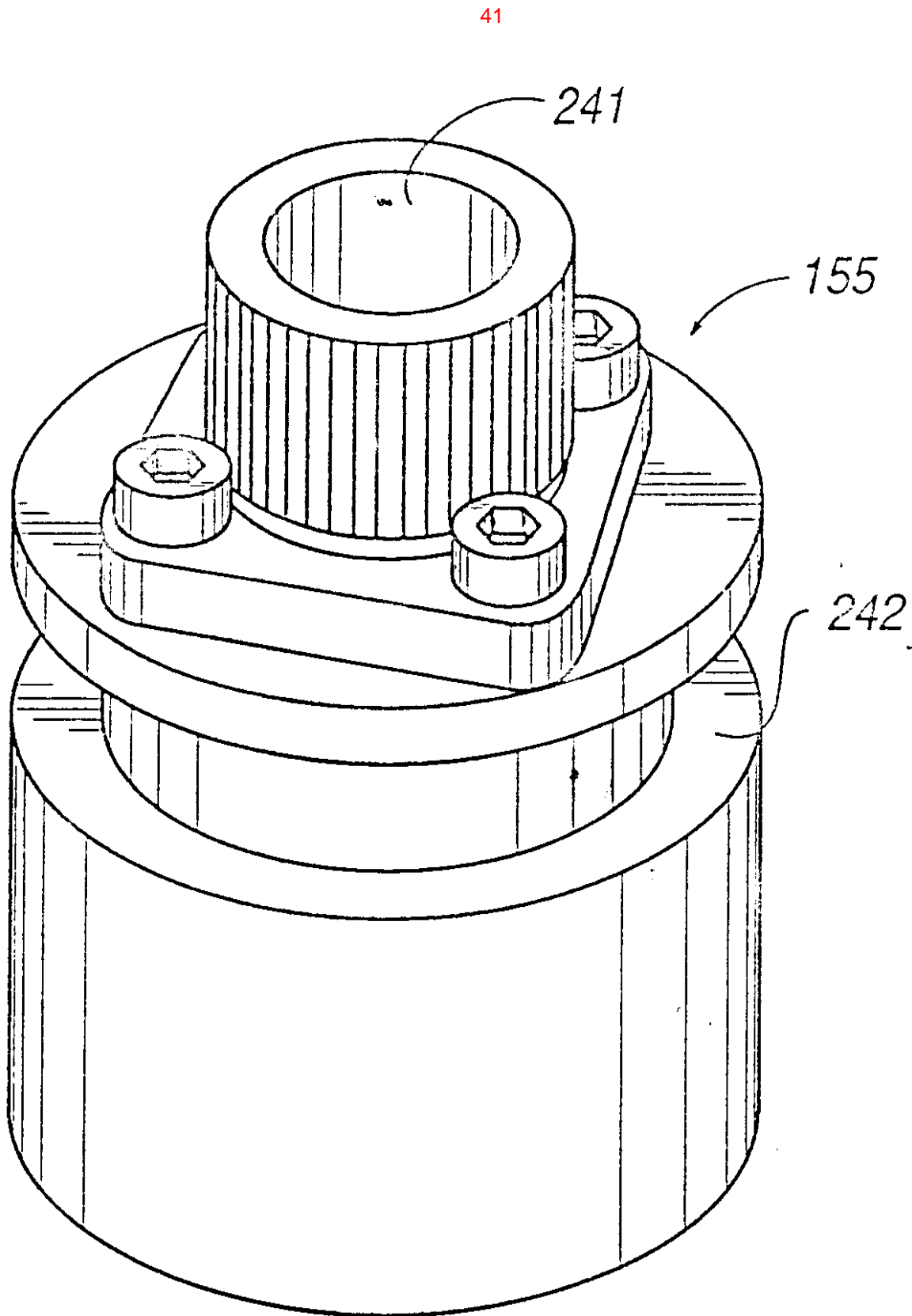

42

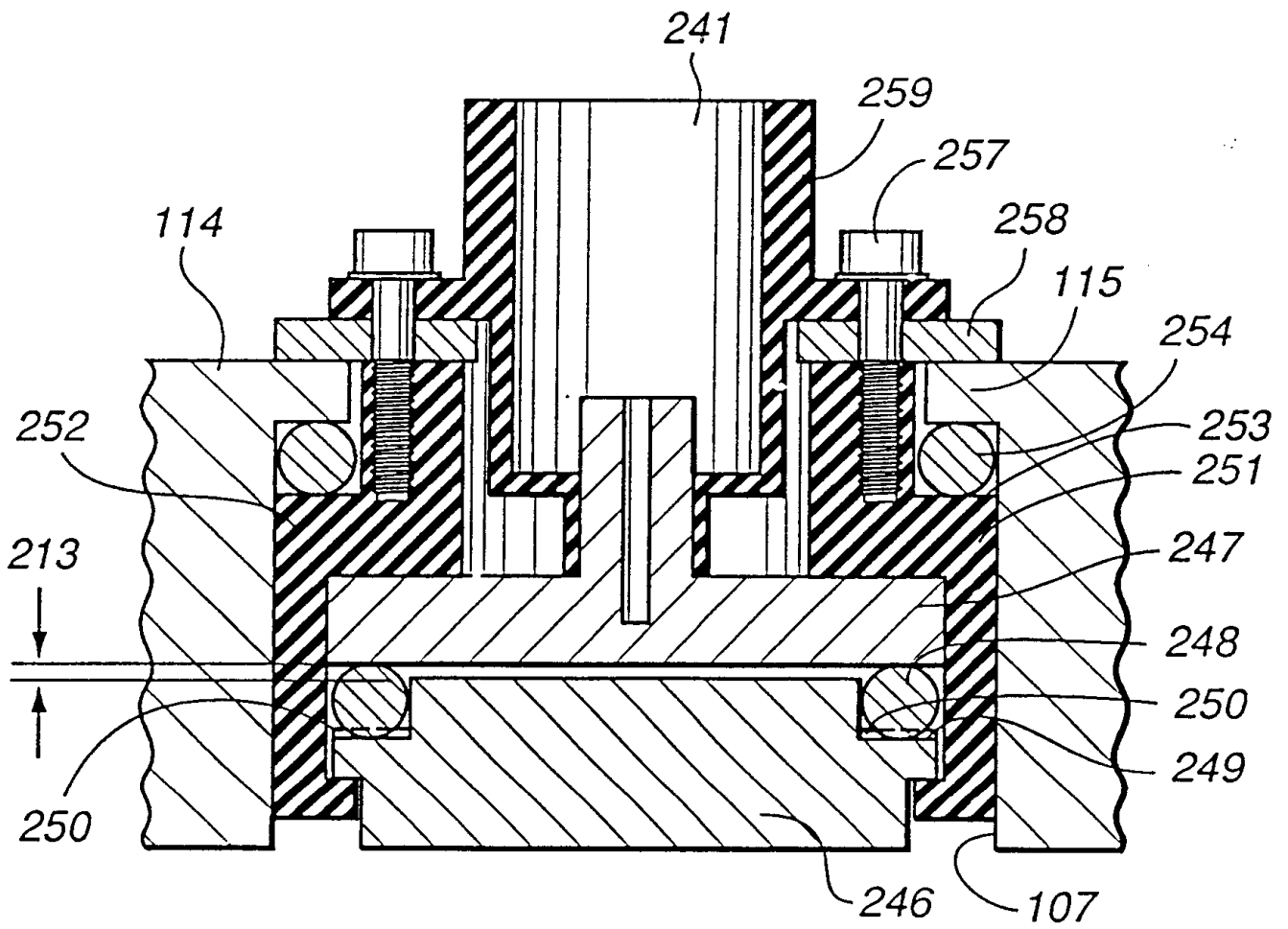

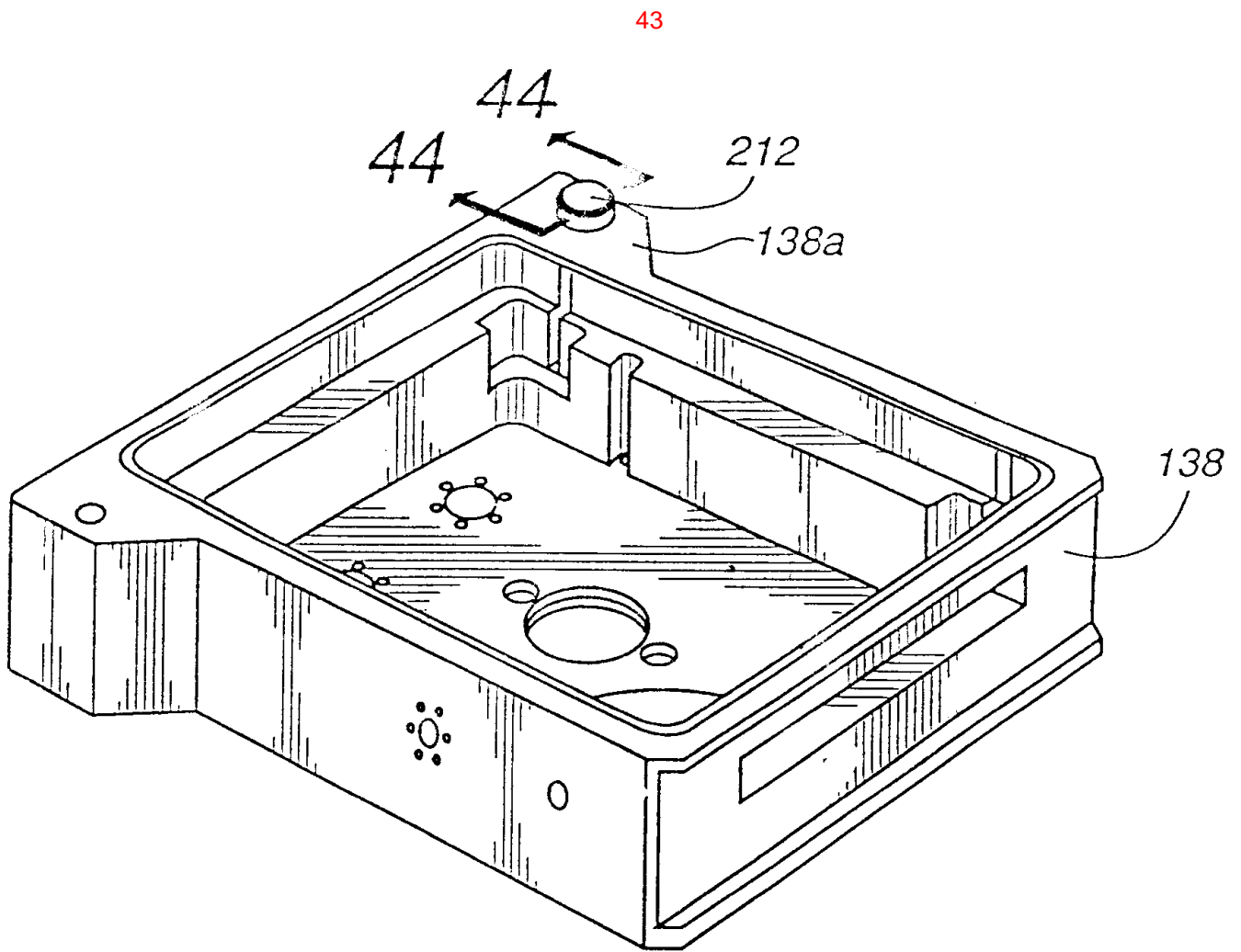

44

