



INTERNATIONAL APPLICATION PUBLISHED UNDER THE PATENT COOPERATION TREATY (PCT)

<p>(51) International Patent Classification <sup>7</sup> : <b>A61N 5/06</b></p>	<p><b>A1</b></p>	<p>(11) International Publication Number: <b>WO 00/41768</b>                   (43) International Publication Date: 20 July 2000 (20.07.00)</p>
---	------------------	---

<p>(21) International Application Number: PCT/US00/00805                  (22) International Filing Date: 14 January 2000 (14.01.00)                  (30) Priority Data:                  09/232,129 15 January 1999 (15.01.99) US                  (71) Applicant (for all designated States except US): LIGHT SCIENCES, LTD [US/US]; No. E-5, 1065 12 Avenue, N.W., Issaquah, WA 98027 (US).                  (72) Inventors; and                  (75) Inventors/Applicants (for US only): CHEN, James [US/US]; 2011 - 87th Place, N.E., Bellevue, WA 98004 (US). WILKERSON, Brian [IL/US]; 18223 S.E. 42nd Place, Issaquah, WA 98027 (US). BROWN, Dave [US/US]; 24832 S.E. 376th Place, Enum Claw, WA 98022 (US). HUSTON, Darrin [US/US]; 37330 246th Avenue, S.E., Enumclaw, WA 98022 (US). MCQUADE, Mike [US/US]; 465 S.E. Bush Street, Issaquah, WA 98027 (US).                  (74) Agents: MAYS, Thomas, D. et al.; Morrison &amp; Foerster LLP, 2000 Pennsylvania Avenue, N.W., Washington, DC 20006-1888 (US).</p>	<p>(81) Designated States: AL, AM, AT, AU, AZ, BA, BB, BG, BR, BY, CA, CH, CN, CR, CU, CZ, DE, DK, DM, EE, ES, FI, GB, GD, GE, GH, GM, HR, HU, ID, IL, IN, IS, JP, KE, KG, KP, KR, KZ, LC, LK, LR, LS, LT, LU, LV, MA, MD, MG, MK, MN, MW, MX, NO, NZ, PL, PT, RO, RU, SD, SE, SG, SI, SK, SL, TJ, TM, TR, TT, UA, UG, US, UZ, VN, YU, ZA, ZW, ARIPO patent (GH, GM, KE, LS, MW, SD, SL, SZ, TZ, UG, ZW), Eurasian patent (AM, AZ, BY, KG, KZ, MD, RU, TJ, TM), European patent (AT, BE, CH, CY, DE, DK, ES, FI, FR, GB, GR, IE, IT, LU, MC, NL, PT, SE), OAPI patent (BF, BJ, CF, CG, CI, CM, GA, GN, GW, ML, MR, NE, SN, TD, TG).</p> <p><b>Published</b>                  With international search report.                  Before the expiration of the time limit for amending the claims and to be republished in the event of the receipt of amendments.</p>
---	--

(54) Title: PATIENT PORTABLE DEVICE FOR PHOTODYNAMIC THERAPY

(57) Abstract

A patient portable photodynamic therapy device securable to a patient includes a lightweight rechargeable battery and a light source, such as an LED or a cold cathode fluorescent (CCF) tube powered thereby. The light source is coupled in light channeling relation to a proximal portion of a biocompatible optical fiber, which includes a distal portion with an optional diffuser that uniformly distributes light as it exits the distal portion. The light channeling between the light source and an optical fiber may be accomplished through any number of lens, including a totally internally reflective (TIR) lens. The distal end of the optical fiber is optionally provided with an anchoring balloon that can be inflated after the optical fiber is properly positioned at a treatment site within a patient's body. The balloon securely lodges the distal portion within the tissue at the treatment site, and is deflated to facilitate the removal of the optical fiber once the treatment is complete.

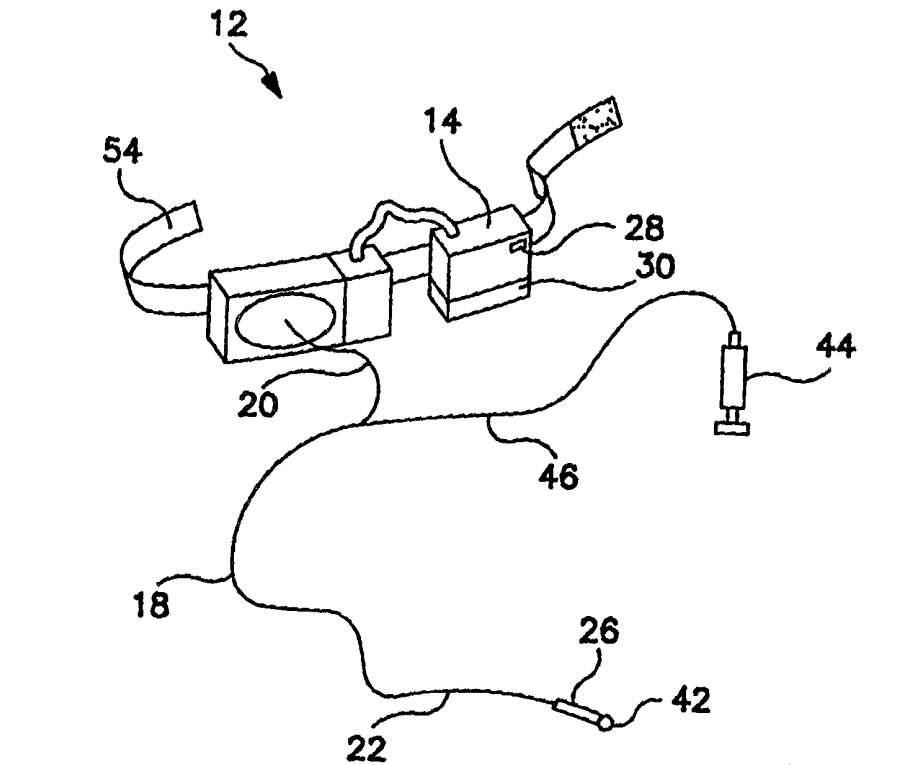

**FOR THE PURPOSES OF INFORMATION ONLY**

Codes used to identify States party to the PCT on the front pages of pamphlets publishing international applications under the PCT.

<b>AL</b>	Albania	<b>ES</b>	Spain	<b>LS</b>	Lesotho	<b>SI</b>	Slovenia
<b>AM</b>	Armenia	<b>FI</b>	Finland	<b>LT</b>	Lithuania	<b>SK</b>	Slovakia
<b>AT</b>	Austria	<b>FR</b>	France	<b>LU</b>	Luxembourg	<b>SN</b>	Senegal
<b>AU</b>	Australia	<b>GA</b>	Gabon	<b>LV</b>	Latvia	<b>SZ</b>	Swaziland
<b>AZ</b>	Azerbaijan	<b>GB</b>	United Kingdom	<b>MC</b>	Monaco	<b>TD</b>	Chad
<b>BA</b>	Bosnia and Herzegovina	<b>GE</b>	Georgia	<b>MD</b>	Republic of Moldova	<b>TG</b>	Togo
<b>BB</b>	Barbados	<b>GH</b>	Ghana	<b>MG</b>	Madagascar	<b>TJ</b>	Tajikistan
<b>BE</b>	Belgium	<b>GN</b>	Guinea	<b>MK</b>	The former Yugoslav Republic of Macedonia	<b>TM</b>	Turkmenistan
<b>BF</b>	Burkina Faso	<b>GR</b>	Greece	<b>ML</b>	Mali	<b>TR</b>	Turkey
<b>BG</b>	Bulgaria	<b>HU</b>	Hungary	<b>MN</b>	Mongolia	<b>TT</b>	Trinidad and Tobago
<b>BJ</b>	Benin	<b>IE</b>	Ireland	<b>MR</b>	Mauritania	<b>UA</b>	Ukraine
<b>BR</b>	Brazil	<b>IL</b>	Israel	<b>MW</b>	Malawi	<b>UG</b>	Uganda
<b>BY</b>	Belarus	<b>IS</b>	Iceland	<b>MX</b>	Mexico	<b>US</b>	United States of America
<b>CA</b>	Canada	<b>IT</b>	Italy	<b>NE</b>	Niger	<b>UZ</b>	Uzbekistan
<b>CF</b>	Central African Republic	<b>JP</b>	Japan	<b>NL</b>	Netherlands	<b>VN</b>	Viet Nam
<b>CG</b>	Congo	<b>KE</b>	Kenya	<b>NO</b>	Norway	<b>YU</b>	Yugoslavia
<b>CH</b>	Switzerland	<b>KG</b>	Kyrgyzstan	<b>NZ</b>	New Zealand	<b>ZW</b>	Zimbabwe
<b>CI</b>	Côte d'Ivoire	<b>KP</b>	Democratic People's Republic of Korea	<b>PL</b>	Poland		
<b>CM</b>	Cameroon	<b>KR</b>	Republic of Korea	<b>PT</b>	Portugal		
<b>CN</b>	China	<b>KZ</b>	Kazakstan	<b>RO</b>	Romania		
<b>CU</b>	Cuba	<b>LC</b>	Saint Lucia	<b>RU</b>	Russian Federation		
<b>CZ</b>	Czech Republic	<b>LI</b>	Liechtenstein	<b>SD</b>	Sudan		
<b>DE</b>	Germany	<b>LK</b>	Sri Lanka	<b>SE</b>	Sweden		
<b>DK</b>	Denmark	<b>LR</b>	Liberia	<b>SG</b>	Singapore		
<b>EE</b>	Estonia						

## PATIENT PORTABLE DEVICE FOR PHOTODYNAMIC THERAPY

### Field of the Invention

This invention relates generally to a light therapy device for activation of medicaments at one or more treatment sites within a living body, and more specifically, to photodynamic therapy devices adapted to reduce dislodgment risk over long treatment periods and enable a patient to be ambulatory without interruption of the therapy.

### Background of the Invention

Photodynamic therapy (PDT) is a two-step treatment process which has been found to be effective in destroying a wide variety of cancers. PDT is performed by first systemically or topically administering a photosensitizer compound, and subsequently illuminating a treatment site with light in a waveband, which corresponds to an absorption waveband of the photosensitizer. The light energy activates the photosensitizer compound, causing it to destroy the diseased tissue.

Numerous systems have been proposed to effectively deliver the activating light to the treatment site. Examples of such systems can be found in U.S. Pat. Nos. 5,519,534 issued May 21, 1996 to Smith, et al., 5,344,434 issued September 6, 1994 to Talmore, and 4,693,556 issued September 15, 1987 to McCaughan. The systems disclosed in these patents generally comprise a laser light source coupled to a proximal end of a flexible biocompatible optical fiber having a distal end adapted to be positioned within the body of a patient, either inside or adjacent to an internal treatment site. The optical fiber conducts and guides activating light from the laser light source to the treatment site at the distal end of the optical fiber. A diffuser enclosing the distal end of the optical fiber diffuses the light, and thus delivers the light to the treatment site at a uniform intensity to effect activation of the photosensitizer compound. In these systems, the diffuser may comprise a sphere positioned on the distal end of the fiber and having an inner partially reflective surface that aids in diffusing light transmitted through the sphere. Other light delivery devices can be found, for example, in U.S. Pat. Nos. 5,709,653 issued January 20, 1998 to Leone, 5,700,243 issued December 23, 1997 to Nariso, and 5,645,562 issued

July 8, 1997 to Hann, et al., and 4,998,930 issued March 21, 1991 to Lundahl. While disclosing systems that are generally similar to the aforementioned systems, these references described diffusers that have an added component. The diffusers of these devices either alternatively or additionally incorporated transparent balloons mounted coaxially around the distal end of the optical fiber. Once the distal end is positioned at the treatment site, the balloon may be inflated in order to increase the area of the treatment site which will be exposed to the activating light, and in some cases, to effect or at least aid in the diffusion of the activating light. Once the light therapy provided by delivery of the light to the treatment site is completed, the balloon may be deflated, and the optical fiber removed from the body of the patient.

A conventional PDT treatment is of very short duration, on the order of minutes, and is typically used to treat superficial and small volume lesions. In order to apply PDT successfully against large lesions, which may be located subcutaneously, more extended treatment sessions must be undertaken. Extending the time of treatment overcomes tumor resistance and enables the extent of the treatment site to be greatly enlarged, thus allowing effective therapy of a much greater tumor volume. Indeed, destruction of a large tumor volume by extended duration PDT has been demonstrated in a clinical treatment. The treated patient suffered from a very large retroperitoneal tumor, which had eroded through the skin. The protruding tumor was treated by inserting multiple light emitting probes, such as is described in commonly assigned U.S. Patent No. 5,445,608, into the substance of the tumor. The probes were energized for more than forty hours after orally administering a dose of a photosensitizer called aminolevulinic acid. This treatment resulted in destruction of just under one-half kilogram of tumor mass over the ensuing four weeks.

While adequate for some applications, the lasers, other high-powered light sources, and optical fibers in current use for administering PDT to a treatment site suffer from several drawbacks related to safety and their inability to accommodate the extended sessions necessary to effectively treat large tumors. First, high-powered sources such as dye lasers, laser diodes, large light emitting diode (LED) arrays, incandescent sources, and other electroluminescent devices are not efficient in converting electrical energy into light energy. They generate significant amounts of

heat, and consume a substantial amount of electrical power. Prolonged use of high intensity light sources can lead to inadvertent tissue damage due to the effect of the high intensity light. Further, certain of these devices, e.g. laser light sources, generate sufficient heat that they must be cooled while activated. The need for cooling necessitates the incorporation of additional hardware such as fans cooling units that draw additional power from the main power supply.

Second, the amount of power consumed by high intensity light sources requires that they be supplied with power from an alternating current (AC) line power source. Movement by the patient or attendance efforts by hospital personnel during the treatment period that cause the patient to move can inadvertently disconnect or damage the power cord, not only interrupting the treatment, but also creating a risk of electric shock. Further, being tethered to a substantially fixed power source limits the application of optical extended treatments, inasmuch as the patient will invariably need to move or be moved during the treatment period. Movement of the patient will likely cause the treatment to be interrupted and thus, render it less effective.

Third, none of the prior art techniques for rendering PDT to an internal treatment site through an optical fiber provides an anchoring mechanism to effectively secure the optical fiber and its distal end within the body of the patient at the treatment site. Any movements by the patient or attendance efforts by hospital personnel during the treatment period could inadvertently pull or dislodge the optical fiber unless it is secured in place. In many cases, while it is easy to disconnect a power cable from a light source to allow the patient to temporarily move about before resuming treatment, it is not practical to remove the optical fiber from the patient's body at that time, as well. Instead, the optical fiber must remain in place while the patient moves about. Without an effective mechanism for securing the optical fiber in the patient's body and at the treatment site while the patient moves, the risk of tissue damage is increased by such activity. Not only can the tissue be torn or severe bleeding occur when the patient moves, but if the dislodgment is not so severe, that it is noticed, the distal end of the optical fiber can be displaced away from the treatment site, so that light is delivered to the wrong area in the patient's body, resulting in possibly severe and unwanted destruction of normal tissue.

Fourth, the methodology of short duration high intensity illumination has drawbacks when applied to treat moderate to large size tumors. These drawbacks include depletion of oxygen necessary for the photodynamic destruction of the tissue that has absorbed the photosensitizer, incomplete activation of the circulating photosensitizer, mis-timing of the illumination session so that the light therapy is not administered during the peak concentration of the photosensitizer drug in the tumor, and the possible recovery of sub-lethally injured tumor cells, which were not completely destroyed due to the short treatment time.

Currently, PDT procedures using laser light sources may be performed during an operation in which a treatment site is surgically exposed, and as such, the period available for administering light therapy is approximately one to two hours at most. The extent of tumor necrosis resulting from such an illumination period is on the order of 1 to 2 centimeters in a zone radially surrounding the optical fiber. Thus, several devices have been developed in an attempt to increase the duration of PDT treatments, to enable the light therapy to continue after an incision in a patient undergoing surgery has been closed. For example, a number of solid state laser devices have been developed for administering PDT that are semi-portable. However, these devices are large, heavy, and must be transported on wheeled carts or other movable furniture. Such "desktop" or semi-portable devices suffer from the drawbacks enumerated above if employed for prolonged PDT treatment periods lasting hours. Furthermore, such light sources must remain connected to the wall power plug by power cables, and the optical fibers through which light produced by the laser is directed to an internal treatment site are prone to dislodgment.

Another light source device, disclosed in U.S. Pat. No. 5,616,140 issued April 1, 1997 to Prescott, can be powered by rechargeable batteries and thus, can be worn by the patient. However, because this device generates only low power laser light, and is not designed to be coupled to optical fibers for directing the light it produces to an internal treatment site, its use is limited to superficial light therapy, e.g., to treating skin lesions. High power lasers currently used for PDT require cooling hardware, and a corresponding power source. Due to weight and size considerations, it is clearly not practical for a patient to move about pushing a high power laser, a cooling unit, and

battery power supplies for the equipment sufficient to provide for a prolonged treatment session.

Accordingly, there is a need for a PDT system to administer light therapy, which reduces the risk of optical fiber dislodgment and allows a patient to move about without interruption of the PDT therapy over treatment periods lasting hours.

Citation of the above documents is not intended as an admission that any of the foregoing is pertinent prior art. All statements as to the date or representation as to the contents of these documents is based on the information available to the applicants and does not constitute any admission as to the correctness of the dates or contents of these documents. Further, all documents referred to throughout this application are incorporated in their entirety by reference herein.

### Summary of the Invention

The present invention is directed to a PDT device enabling efficacious treatment of relatively large tumors that are currently not treatable using conventional PDT delivery systems and methodologies and is specially adapted to reduce the risk of dislodging an optical fiber from a treatment site and when the patient moves about. The patient can thus be ambulatory without interruption of the light therapy over long treatment periods. In a preferred embodiment, the present invention comprises a belt or harness that supports and secures a lightweight rechargeable battery and a cold cathode fluorescent (CCF) tube powered thereby to a patient. The CCF tube is coupled to a proximal portion of the optical fiber. A distal portion of the optical fiber is provided with means for diffusing light as it exits the optical fiber. The distal portion of the fiber is adapted to be positioned at a treatment site within a patient's body by a medical practitioner. A balloon disposed at a distal end of the optical fiber can be inflated after the insertion of the optical fiber within the patient's body, to secure the distal portion of the fiber within the tissue at the treatment site; the balloon is deflated prior to the removal of the optical fiber, once administration of the light therapy is completed.

The present invention overcomes the limitations of the prior art PDT delivery devices in several respects. First, the use of a CCF tube provides increased

effectiveness and efficiency compared to laser light sources. Light energy losses due to coupling of the light source to the optical fiber are further minimized by optionally employing a parabolic reflector and lens to focus the light into the proximal portion of the optical fiber. It is possible to obtain a greater zone of necrosis using non-laser  
5 light delivered to the tumor mass over a longer period of time, for example, 40 hours. Therefore, a CCF tube is preferred over other light sources, such as solid laser diodes, fiber lasers, LEDs, incandescent sources, halogen sources, polymeric luminescent devices or other electroluminescent devices, because CCF tube is generally more efficient in converting electrical power to light energy. As such, it not only generates  
10 a minimal amount of heat, but also consumes a minimal amount of power, thereby eliminating the need for cooling fans and large or substantially fixed power supplies. In contrast, the alternative light sources listed above suffer from lower conversion efficiencies, generate more heat, and require greater amounts of electrical power.

A second advantage is that the use of a CCF tube allows the present invention  
15 to be powered by a portable power supply that employs widely available and commonly used rechargeable batteries such as lithium ion, nickel metal hydride, and nickel cadmium rechargeable batteries, which are lightweight and inexpensive. In contrast, the need for at least some of the other types of light sources to be accompanied by cooling fans, and even cooling systems (with the need for an  
20 additional power supply to run the cooling system), makes it impractical for them to be adapted to a portable system, because they are too bulky, weigh too much, and are too expensive. It is not a trivial advantage for the present invention to be readily portable and free from being continuously linked to a stationary or permanent power source. As the present invention can be carried about by the patient on a belt or  
25 harness, there are no power cables, which can be severed or pulled from a fixed power source due to inadvertent movements by the patient. Thus, the risk of treatment interruption and electric shock is minimized. More importantly, the patient will be able to undergo optimal extended treatment sessions, as the patient will be able to move freely or be moved without interruption of the treatment. The ability of a CCF  
30 tube to be formed into various compact shapes, including "U"s, coils, spirals, and elongate forms, further facilitates the efficient administration of light to various



correspondingly shaped treatment sites by the present invention and permits the system to be worn and transported by the patient easily and comfortably.

A third advantage provided by the present invention is that it enables a CCF tube to be easily coupled in light channeling relation to the proximal portion of at least one biocompatible optical fiber. The biocompatible optical fiber is flexible not only inasmuch as its distal portion can be easily positioned within the tissue of the patient at a treatment site, but also because it can accommodate movement of surrounding tissue associated with patient respiration and ambulation. Optionally, a parabolic mirror is positioned partially surrounding in relation to the CCF tube and a focusing lens positioned between the CCF tube and the proximal portion of the fiber cooperate to channel light into the proximal portion of the fiber. Specifically, the parabolic mirror reflects light from the CCF tube onto the focusing lens which focuses the light into the proximal portion of the optical fiber. After the light travels through the optical fiber, it is diffused at the distal portion of the optical fiber by a diffuser of the types that are well known and documented in the art. The diffusion of the light emitted from the distal portion of the optical fiber enables the light to be administered more uniformly to the treatment site to activate the photosensitive compound previously administered. The length of the optical fiber is preferably limited to that necessary to reach the treatment site, in order to minimize light loss along the length of the optical fiber. The outer coating of the optical fiber is preferably opaque to light, in order to prevent light leaking from the optical fiber activating any photosensitizer absorbed by normal tissue along the length of the fiber. Additional biocompatible optical fibers may be connected to the focusing lens or parabolic mirror and focusing lens coupling the light into the proximal portions of the optical fibers or alternatively, may be spliced into the biocompatible optical fiber into which the light is focused.

A fourth advantage of the present invention over the prior art devices is that it optionally includes anchoring means for securing the optical fiber and particularly, its distal portion within the body of the patient at the treatment site. The balloon mounted to the distal end of the optical fiber can be inflated with a pressurized fluid such as air that flows through a lumen that extends substantially parallel to and which is disposed within or adjacent to the optical fiber. This lumen is thus maneuverable

with the optical fiber. The lumen runs substantially the length of the optical fiber, from the pressurized fluid source that is external to the patient's body to the balloon at the distal end of the optical fiber. After positioning the distal portion of the fiber within the tissue of the patient at the treatment site, the balloon is inflated to secure the distal end of the optical fiber in the tissue. The inflated balloon also tamponades any bleeding, which may occur at the distal end of the optical fiber during its insertion. Thus, any movement by the patient during the treatment will not dislodge the optical fiber or its distal portion because the balloon anchors the optical fiber in place. Similarly, movement of the distal portion of the optical fiber will thus be avoided, preventing light from being administered to healthy tissue that has absorbed the photosensitizer. Overall, the risk of damage to normal tissue is minimized, and the need for the patient to interrupt treatment before moving about is eliminated. Once treatment is complete, the balloon is deflated to facilitate removal of the optical fiber from the patient's body. It should be noted that for some applications, the distal portion of the optical fiber should preferably abut, rather than be embedded in the treatment site. This may be the case where, for example, it is undesirable or difficult to penetrate the tumor or diseased tissue. In such a situation, the balloon may be positioned at an intermediate point along the length of the optical fiber and/or in coaxially surrounding relation to the optical fiber, rather than at its distal end.

The above features and advantages of the present invention will be better understood upon a reading of the following detailed description with reference to the accompanying drawings.

### **Brief Description of the Drawings**

The foregoing aspects and many of the attendant advantages of this invention will become more readily appreciated as the same becomes better understood by reference to the following detailed description, when taken in conjunction with the accompanying drawings, wherein:

FIGURE 1 is a perspective view of a patient portable PDT device according to a preferred embodiment of the present invention;

FIGURE 2 is an expanded cut-away perspective view of a light source used in the patient portable PDT device, according to a preferred embodiment of the present invention;

FIGURE 3 is an expanded sectional view of light channeling coupling means of the patient portable PDT device, according to a preferred embodiment of the present invention;

FIGURE 4 is an expanded view of a distal portion anchoring means of the patient portable PDT device;

FIGURE 5 is a perspective view of the patient portable PDT device being worn by a patient;

FIGURE 6 is a cut away illustration of the positioning of a needle having a peel away sheath that is employed for inserting an optical fiber used in the patient portable PDT device;

FIGURE 7 is a cutaway illustration of the positioning and anchoring of a distal portion of the optical fiber;

FIGURE 8 is cutaway illustration of the positioning and anchoring of the distal portion of the optical fiber;

FIGURE 9 is a cutaway illustration of the positioning and anchoring of the distal portion of the optical fiber in the bladder, with the light diffuser portion of the optical fiber disposed in the prostatic portion of a patient's urethra; and

FIGURES 10A and 10B are expanded sectional views of an aspect of a light channeling coupling means having a TIR lens of the patient portable PDT device, according to a preferred embodiment of the present invention.

### **Description of the Preferred Embodiment**

While the present invention will be described more fully hereinafter with reference to the accompanying drawings, it is to be understood that persons skilled in the art may modify the invention herein described while achieving the functions and results of the invention. Accordingly, the descriptions which follow are to be understood as illustrative and exemplary of specific structures, aspects and features

within the broad scope of the present invention and not as limiting of such broad scope.

Referring now to FIGURES 1, 2 and 3, a patient portable PDT device 12 according to the present invention comprises a power source, or lithium ion rechargeable battery pack 14; a light source, or CCF tube 16 formed into an elongated “U” shape (best shown in FIGURE 2) and adapted to draw power from the battery pack 14; at least one biocompatible optical fiber 18 (only one is shown) having a proximal portion 20 and a distal portion 22, and adapted to channel light between the proximal portion 20 and the distal portion 22; and a coupling means 24 for coupling the CCF tube 16 in light channeling relation to the proximal portion 20 of the optical fiber 18 (best shown in FIGURE 3). The optical fiber 18 is equipped with a diffusion means 26 (best shown in FIGURE 1) for diffusing light as it exits the distal portion 22 of the optical fiber 18. The battery pack 14 includes a warning light 28 and backup power reserve 30.

It should be readily apparent to one skilled in the art, based on the instant disclosure, to alternatively use the following items in addition to or in place of their respective presently shown components, without departing from the broad scope of the present invention. For the lithium ion rechargeable battery pack 14, one may use one or more nickel cadmium rechargeable batteries, one or more nickel metal hydride rechargeable batteries, or fuel cells, any other type of electrical power source polymer batteries, one or more, other rechargeable batteries or non-chargeable batteries that are sufficiently compact and substantially lightweight to be readily portable, i.e., readily carried about by the patient. Such a power source should preferably operate at a relatively low or ambient temperature. In addition, instead of the CCF tube 16, one or more laser diodes, fiber lasers, LEDs, incandescent lights, halogen lights, polymeric luminescent devices, other types of fluorescent lights, discharge lamps, or other electroluminescent devices can be employed for the light source, including those having at least one of the characteristics of being substantially compact, substantially lightweight, operating at a substantially low temperature, or being self-contained so that the light source is suitable for a portable system that is readily carried about by

the patient. For the diffusion means 26, any of the diffusers well known and documented in the prior art are suitable.

Referring now specifically to FIGURES 2 and 3, the preferred coupling means 24 employed to channel light emitted by the light source in the proximal end of the optical fiber comprises a focusing lens 32 having a convex receiver side 34 and a convex delivery side 36; and a parabolic mirror 38 positioned so that the CCF tube 16 is generally disposed at or adjacent to the focal point of the parabolic mirror. The focusing lens 32 is positioned between the CCF tube 16 and the proximal portion 20 of the optical fiber 18, so that the focusing lens receives the directly transmitted light from the CCF tube and the light reflected by the parabolic mirror 38 and focuses the light into the proximal end of the optical fiber 18. It should be readily apparent to one skilled in the art, based on the instant disclosure, to alternatively use in addition to or in place of the components disclosed for coupling means 24, one or more mirrors, concave lenses, or convex lenses, in appropriate configurations that channel light emitted by the light source into the proximal portion of the optical fiber, without departing from the broad scope of the present invention.

A number of various lens types are contemplated for use in the present invention, as has already been discussed. Additionally and referring to FIGURE 10, a totally internally reflecting (TIR) lens can be used to efficiently focus light from a light source into an optical fiber, in a preferred embodiment of the invention. One examples of a TIR lens is described in U.S. Pat. No. 5,404,869, which is hereby incorporated by reference in its entirety.

A TIR lens can very efficiently focus light from a number of sources, including an LED source as shown in FIGURE 10A, for example. Thus, light from a very lightweight, compact, point source can be directed into an optical fiber for ambulatory PDT. Such an LED source can be battery powered for portable, wearable use.

A TIR lens in an optimized orientation and angle of curvature can also be used to focus light from a diffuse light source such as sunlight into an optical fiber for use in PDT as shown in FIGURE 10B. A further aspect of the present invention includes optionally providing a battery powered light source as a backup source of light when

collecting diffuse light from a source such as sunlight.

TIR lens are generally characterized, as provided in U.S. Pat. No. 5,404,869, by the use of a transparent means employing elements to redirect radiant energy by means of TIR alone, or in conjunction with refraction, such means positioned between the radiant energy source and a receiver. Each element redirects radiant energy upon a common target zone or zones, during the energy's internal passage through the element. A properly oriented ray enters through the entry face and strikes the reflective face, which redirects it toward the exit face, the three faces comprising the active faces for that ray. In addition, the lens means is associated with at least one of the faces for redirecting radiant energy passing between the entry and exit faces via the TIR face. The curvature of the faces of the individual lens elements may be provided at one, two or all three of the faces (entry, exit and TIR) and, for example, may constitute a concave entry face, a convex exit face, and/or a convex TIR face. The facet design of the TIR lens has four degrees of freedom: the angle of the entry face, the angle of the TIR face, the angle of the exit face, and the position of the inwardly adjacent facet.

An important use of facet curvature is in a small TIR lens with only a few facets, such as a collimator for a light-emitting diode. The TIR lens can be incorporated into the conventional transparent cover of an LED, greatly improving its luminous efficiency. Further the TIR lens may be used as an illumination injector for optical fiber bundles and light pipes. The TIR lens has a focal cone half angle matched to the acceptance angle of the target. Two types of linearly symmetric TIR lenses for cylindrical sources (such as fluorescent tubes): One that confines its output to a relatively narrow off-axis angle and one that reduces its on-axis output and enhances the lateral output, in order to produce uniform illumination on a nearby surface that is being used for indirect lighting. A more useful lens design would be applied to a toroidal fluorescent lamp. The TIR lens profile would have its axis of symmetry over the circular cross-section of the toroidal lamp. The complete lens would be a figure of revolution with its axis being that of the toroid rather than the center of the lens profile. The more slender the toroidal lamp, the better could its light be controlled by the lens. This toroidal TIR lens is very useful for battery-powered

fluorescent lamps, which generally cannot provide any focusing whatsoever. A collimating TIR lens may be made of silicon, and with the high refractive index of this material, the refractive faces of its facets would be somewhat differently angled than those of a glass lens. The application for a silicon lens is for the collimation of infrared light and the exclusion of visible light (because silicon absorbs all wavelengths shorter than 1.1 micrometers).

It should be clearly understood that one or more light sources can be mated to the TIR lens. For example, multiple LEDs may be arranged in virtually any symmetric pattern on the collecting surface of a lens in order to launch more light into a fiber compared to one LED on the surface of a given lens. It is understood that experimentation to study different LED configurations will yield the optimal pattern of LED arrangement for a given lens. Also, LEDs or other light sources of differing wavebands and wavelengths may be "mixed" in order to broaden the waveband of light launched into the receiving fiber.

Referring now also to FIGURE 4, the present invention further comprises an anchoring means 40 for anchoring the distal portion 22 of the optical fiber 18 within a patient's body. The anchoring means 40 preferably comprises a balloon 42 attached to the optical fiber 18, a pressurized air source 44 which may be a syringe which is configured to deliver pressurized air (or other pressurized fluid) to the balloon 42, a lumen 46 communicating between the air source 44 and the balloon 42, and a selection means, or control 48 and valve 50 for selectively delivering pressurized air from the pressurized air source 44 to the balloon 42 and exhausting the pressurized air from the balloon 42, so as to enable the selective inflation and deflation of the balloon. In this preferred embodiment, the optical fiber 18 has a distal end 52 on which the balloon 42 is mounted. The lumen 46 extends in substantially parallel relationship to the optical fiber 18 and runs substantially the length of the optical fiber 18, affixed to the side of the optical fiber over much of its length. Alternatively, the lumen is disposed within the optical fiber. Hollow optical fibers are well known in the optical fiber prior art.

It should be readily apparent to one skilled in the art, based on the instant disclosure, that one or more balloons (or other devices inflatable with pressurized

fluids), lumens (or other channels capable of transporting gases or fluids), pressurized fluid sources, and/or other types of selection means (such as valves, switches, plugs or computer-, electrically- or mechanically-controlled components), can be employed in the present invention, in various configurations and combinations, without departing  
5 from the broad scope of the present invention. For example, a heat activated shape memory metal anchor, for example, one activated by heat developed by passing an electrical current therethrough, can be employed to hold the optical fiber in place.

Referring now also to FIGURE 5, the battery pack 14, CCF tube 16 (best shown in FIGURE 2) and coupling means 24 (best shown in FIGURE 3) are mounted  
10 to means for enabling a patient to easily transport the battery pack 14, CCF tube 16, and coupling means 24, i.e., at least one belt 54 (only one is shown) and are thus supported and substantially secured to a patient's body 56 as shown. While the pressurized air source 44 (best shown in FIGURE 4) can also be mounted to the belt 54 and thus supported and substantially secured to a patient's body 56, it is likely that  
15 the air source, preferably a syringe will be used to initially inflate the balloon after the distal end of the optical fiber is properly positioned at the treatment site and thereafter be disconnected, provided that the pressurized fluid is retained within balloon until the optical fiber can be removed from the patient after the treatment is completed. It should be readily apparent to one skilled in the art, based on the instant disclosure, to  
20 alternatively use in addition to or in place of belt 54, one or more other belts, one or more harnesses, vests, straps, pockets, flaps, buckles, or hook-and-loop or other connection straps, in various combinations and configurations, to secure at least the light source and portable power supply to the patient's person, without departing from the broad scope of the present invention.

Referring now to FIGURES 6 and 7, after the photosensitizer drug (not  
25 shown) is administered to the treatment site 58 within the patient's body 56 (not shown in full), a needle 60 having a peel away sheath 62 is inserted into the patient's body while observed using an appropriate imaging system (such as CT, Ultrasound, MRI, X-ray) to the treatment site 58 within the patient's body 56 (not shown in full).  
30 Though image guidance is preferred for achieving an accurate disposition of the optical fiber, it is optional and is not necessary, especially for disposition of the



optical fiber to treat superficial lesions. The needle 60 is removed and the optical fiber 18 with the balloon 42 deflated is passed through the peel away sheath which was previously properly positioned at the treatment site. The position of the distal portion 22 is confirmed via the imaging modality used to pass the needle 60, and the peel away sheath 62 is pulled up and split apart. The position of the distal portion 22 is then reconfirmed. The proximal portion of the optical fiber 18 is secured to the skin of the patient at an exit point 64 by way of suture, adhesive tape, or other fixation means (not shown). The pressurized air source 44 (best shown in FIGURE 4) is coupled to the lumen 46, and pressurized air from the pressurized air source 44 is delivered to the balloon 42 in volume sufficient to inflate the balloon 42 so as to anchor the distal portion 22 of the optical fiber 18 at the treatment site 58 and tamponade any bleeding, which may have occurred during the introduction of the optical fiber 18 into the patient's body. Once the balloon 42 is sufficiently inflated, the pressurized air source 44 is uncoupled from the lumen 46. The pressurized air is prevented from escaping from the lumen 46 by the valve 50 (best seen in FIGURE 4). Any dislodgment or displacement of the optical fiber 18 or its distal portion 22 due to movement of the patient will be resisted by the inflated balloon 42.

Once the balloon 42 has been inflated, the patient fastens the belt 54 (best shown in FIGURE 5), which supports and secures the battery pack 14, CCF tube 16 (best shown in FIGURE 2), and coupling means 24 (best shown in FIGURE 3) to the patient. The battery pack 14, CCF tube 16, and coupling means 24 collectively are sufficiently compact and lightweight to be easily transported by the patient, and movement about by the patient during extended treatments is thus greatly facilitated. The CCF tube 16 is coupled to the battery pack 14 so as to draw electrical power. The proximal portion 20 of the optical fiber 18 is coupled to the CCF tube 16 by the coupling means 24 (best shown in FIGURE 3). Other coupling means are possible as well, such as those described in U.S. Patent No. 5,769,844. Different lengths of optical fiber 18 are available so that the shortest length possible can be employed to minimize light loss. A slight amount of slack in the optical fiber is allowed so that bending, twisting, turning, and other movements by the patient are accommodated. To begin treatment, the CCF tube 16 is activated with electrical current from the

battery pack. As best shown in FIGURE 3, a quantity of light from the CCF tube 16 is reflected by the parabolic mirror 38 onto the receiver side 34 of the focusing lens 32. The focusing lens 32 focuses light from the parabolic reflector and from the CCF tube into the proximal portion 20 of the optical fiber 18. The light is channeled  
5 through the optical fiber 18 to the distal portion 22 of the optical fiber 18, where it exits the distal portion 22 and is diffused by the diffusion means 26. This diffused light is thus delivered to the treatment site 58 in a uniform manner.

The battery pack 14 preferably provides at least 2 to 3 hours of operating time, depending on the power consumption of the light source, before it must be recharged.  
10 However, inasmuch as it is removable and modular, it can be immediately replaced with a fresh battery pack and later recharged without interruption of the therapy. Once the battery pack 14 begins to lose power, the warning light 28 on the battery pack 14 alerts the patient that the battery pack 14 must be replaced soon. The backup power reserve 30 provides the CCF tube 16 with power while the patient replaces the  
15 battery pack 14 with a fresh battery pack (not shown).

Once treatment is complete, or in the event that treatment must be halted prior the completion, the CCF tube 16 can be deactivated, the optical fiber 18 can be uncoupled from the coupling means 24, and the valve 50 can be opened to allow the pressurized air in the balloon 42 to escape, to deflate the balloon 42. Under the  
20 supervision of medically trained personnel, the suture or adhesive tape securing the proximal portion of the optical fiber 18 to the patient's body 56 at the exit point 64 can be removed, and the optical fiber 18 can be withdrawn from the patient's body.

Referring now to FIGURE 8, alternate preferred embodiments may incorporate a different positioning of the balloon 42, such as at an intermediate point  
25 along the length of the optical fiber 18 to enable the distal portion 22 of the optical fiber 18 to abut a treatment site 58 as shown, rather than to be inserted within the treatment site 58. In this embodiment, light is directed toward the treatment site by a microlens 59 attached to the distal end of the fiber optic. The lens 59 enables light to be focused onto the peripheral boundary of the treatment site and penetrate into its  
30 depths without actually having to insert the fiber optic into the treatment site. Administering light therapy to the surface of the treatment site is preferable when the

site should not be punctured with a needle, such as in the care of a highly vascular lesion, which would bleed excessively if the needle passed through a blood vessel.

Referring again to FIGURES 1 and 7, another aspect of the present invention is directed to a method for delivering light to a treatment site, comprising the steps of  
5 employing the power source, or battery pack 14 to energize the light source, or CCF tube 16; coupling the CCF tube 16 in light channeling relation to the proximal portion 20 of the biocompatible optical fiber 18; positioning the distal portion 22 of the optical fiber at the treatment site 58 within a patient's body; and administering the light through the optical fiber 18 to the treatment site 58. More specifically, the CCF  
10 tube 16 can be coupled in light channeling relation to the proximal portion 20 by the coupling means 24 described in detail above and shown in FIGURE 3. However, as noted above, it should be readily apparent to one skilled in the art, based on the instant disclosure that in addition to or in place of the presently shown coupling means 24, one or more mirrors, concave lenses, or convex lenses, in varying configurations can  
15 be used to channel the light into the optical fiber, without departing from the broad scope of the present invention. The distal portion 22 can be positioned at the treatment site 58 in the manner outlined in detail above and shown in FIGURE 6 where a needle 60 having a peel away sheath 62 is passed under image guidance (such as CT, Ultrasound, X-ray) to the treatment site 58. After the needle 60 is withdrawn,  
20 the optical fiber 18 with the balloon 42 deflated is inserted through the peel away sheath. The position of the distal portion 22 is confirmed via the imaging modality used to position the needle 60, and the peel away sheath 62 is pulled up and split apart. The position of the distal portion 22 is then reconfirmed. However, it should be readily apparent to one skilled in the art, based on the instant disclosure, that  
25 alternative steps maybe used in addition to or in place of those described above, without departing from the broad scope of the present invention.

FIGURE 9 illustrates treatment of a bladder 65 wherein the balloon 42 is inflated on the inside of the bladder wall 66 to keep the diffusion means 26 properly inserted in the urethra 67. The prostate gland 68 is also schematically represented.

Referring now again also to FIGURE 4, another aspect of the present invention is directed to a method for anchoring the distal portion 22 of the optical  
30

fiber 18 at the treatment site 58. This method includes the steps of mounting the balloon 42 to the optical fiber 18; coupling the pressurized air source 44, configured to deliver pressurized air, in selective fluid communication with the balloon 42; positioning the balloon 42 (deflated) with the distal portion 22 into the treatment site 58; and activating the pressurized air source 44 to inflate the balloon 42 after positioning of the distal portion 22 of the optical fiber at the treatment site 58. More specifically, the pressurized air source 44 can be selectively coupled in fluid communication to the balloon 42 by the lumen 46 described in detail above, and employing the control 48 and valve 50 to control the inflation and deflation of the balloon, as described.

As further explained above, the balloon 42 may be positioned at the distal end 52 of the optical fiber 18 as shown in FIGURE 7, or at any intermediate point along the length of the optical fiber 18 as shown in FIGURE 8. As noted above, it should be readily apparent to one skilled in the art, based on the instant disclosure, to alternatively use in addition to or in place of the components described for anchoring means 40, one or more balloons (or other devices inflatable by gases or fluids), lumens (or other channels capable of transporting gases or fluids), pressurized fluid sources (or other gas or fluid sources), and selection means (such as valves, switches, plugs, or computer-, mechanically- or electrically-controlled components, such as shape memory metal anchoring devices), in various configurations and combinations, without departing from the broad scope of the present invention.

Referring now again also to FIGURE 5, yet another aspect of the present invention pertains to a method for securing the battery pack 14 and the CCF tube 16 to a patient. This method comprises the steps of securing the battery pack 14 and the CCF tube 16 to the belt 56 and attaching the belt 56 to a patient, as shown in FIGURE 5. As noted above, it should be readily apparent to one skilled in the art, based on the instant disclosure, to alternatively use in addition to or in place of the belt 54, one or more other belts, harnesses, vests, straps, pockets, flaps, buckles, or hook-and-loop straps, or other connectors, in various combinations and configurations, without departing from the broad scope of the present invention.

Although the present invention has been described in connection with the preferred form of practicing it and in regard to alternative embodiments, those of ordinary skill in the art will understand that many other modifications can be made thereto within the scope of the claims that follow. Accordingly, it is not intended that  
5 the scope of the invention in any way be limited by the above description, but instead be determined entirely by reference to the claims that follow.

**WHAT IS CLAIMED IS:**

1. A patient portable light therapy device, comprising:

a portable power source that stores electrical energy;

5 a light source coupled to said portable power source and adapted to be energized thereby; and

at least one optical fiber having a proximal portion coupled to the light source and a distal portion adapted to be disposed at a treatment site, said at least one optical fiber conveying light emitted by the light source to the distal portion to administer  
10 light therapy to the treatment site, said portable power source, said light source, and said at least one optical fiber being sufficiently light in weight and sufficiently compact so as to be readily carried about by a patient while the light source is administering the light therapy to the treatment site.

2. A patient portable light therapy device, comprising:

a portable power source that stores electrical energy;

15 a light source coupled to said portable power source and adapted to be energized thereby;

a totally internally reflecting lens positioned adjacent to said light source; and

20 at least one optical fiber having a proximal portion coupled to said totally internally reflective lens and a distal portion adapted to be disposed at a treatment site, said at least one optical fiber conveying light emitted by the light source to the distal portion to administer light therapy to the treatment site, said portable power source, said light source, and said at least one optical fiber being sufficiently light in weight  
25 and sufficiently compact so as to be readily carried about by a patient while the light source is administering the light therapy to the treatment site; and

wherein said totally internally reflecting lens focuses light from said light source to said optical fiber.

3. The device of claim 1 or 2, further comprising a focusing lens, and a  
30 parabolic mirror positioned adjacent to said light source so as to reflect a quantity of

light from said light source onto the focusing lens; and wherein the focusing lens is disposed between said light source and the proximal portion of said at least one optical fiber and is adapted to receive the quantity of light, transmit a portion of the quantity of light, and focus at least part of the portion of the quantity of light into the proximal portion of the optical fiber.

4. The device of claim 1 or 2, wherein at least one of said portable power source and said light source is self-contained.

5. The device of claim 1 or 2, wherein said portable power source is rechargeable.

6. The device of claim 1 or 2, wherein said portable power source comprises one of a battery and a fuel cell.

7. The device of claim 1 or 2, wherein said light source is selected from the group consisting of: one or more laser diodes, fiber lasers, LEDs, non-laser light source, cold cathode fluorescent tube, incandescent lights, halogen lights, polymeric luminescent devices, other types of fluorescent lights, discharge lamps, and other electroluminescent devices.

8. The device of claim 1 or 2, further comprising a focusing lens, wherein said focusing lens is selected from the group consisting of: a concave lens, a convex lens, and a totally internally reflecting lens; and

wherein said focusing lens is disposed between said light source and the proximal portion of said at least one optical fiber and is adapted to receive the quantity of light, transmit a portion of the quantity of light, and focus at least part of the portion of the quantity of light into the proximal portion of the optical fiber; and

wherein said device of claim 1 or 2, optionally further comprises a parabolic mirror positioned adjacent to said light source so as to reflect a quantity of light from said light source onto the focusing lens.

9. The device of claim 8, wherein said light source is a plurality of LEDs and wherein said focusing lens is a totally internally reflective lens.

5 10. The device of claim 1 or 2, further comprising a carrier for said portable power source, and said light source, wherein said carrier comprises one of a belt, a harness, and a pack adapted to support and enable a patient to carry said portable power source, and said light source.

10 11. The device of claim 1 or 2, further comprising:  
an elastomeric membrane having a volume that is selectively varied to anchor the distal portion of said at least one optical fiber within a patient's body;  
and wherein said elastomeric membrane is biocompatible.

15 12. The device of claim 10, wherein said elastomeric membrane comprises:  
a balloon attached to said at least one optical fiber; and  
a source of pressurized fluid that is coupled in fluid communication to selectively inflate said balloon lumen.

20 13. The device of claim 10, wherein said balloon is coupled in fluid communication with the source of pressurized fluid by a fluid channel that extends along said at least one optical fiber to said balloon from the source of pressurized fluid.

25 14. The device of claim 12, wherein said fluid channel is substantially coaxial with said at least one optical fiber.

30 15. The device of claim 11, wherein said balloon is mounted around said distal portion of said at least one optical fiber.



16. The device of claim 11, wherein said balloon is mounted around said at least one optical fiber, at an intermediate point.

17. The device of claim 1, wherein said at least one optical fiber is  
5 equipped with means for diffusing light as it exits the distal portion of said at least one optical fiber.

18. A method for delivering light to a treatment site of a patient to administer a light therapy thereto, comprising the steps of:

10 providing a portable power source, a light source, and an optical fiber;  
positioning a distal portion of said optical fiber at the treatment site;  
energizing said light source with the portable power supply; and  
administering the light treatment to the treatment site with the light source,  
wherein said patient is ambulatory without interruption of the light therapy during the  
15 treatment.

19. A method for delivering light to a treatment site of a patient to administer a light therapy thereto, comprising the steps of:

20 providing a portable power source, a light source, a totally internally reflecting lens, and an optical fiber;  
positioning a distal portion of said optical fiber at the treatment site;  
energizing said light source with the portable power supply; and  
administering the light treatment to the treatment site with the light source,  
wherein said patient is ambulatory without interruption of the light therapy during the  
25 treatment.

20. The method of claim 18 or 19, wherein:  
said treatment site is within a patient's body; and  
a distal end of said optical fiber is implanted within the patient's body.

21. The method of claim 18 or 19, further comprising a step of securing a distal portion of said optical fiber at the treatment site.

22. The method of claim 18 or 19, wherein said securing step comprises the steps of: mounting a balloon to said of optical fiber;  
coupling a pressurized fluid source lumen in fluid communication with said balloon; and  
inflating said balloon with said pressurized fluid after positioning the distal portion of the optical fiber at the treatment site.

23. The method of claim 18 or 19, further comprising a step of substantially securing said portable power source and said light source to a patient while the light therapy is being administered.

24. The method of claim 18 or 19, wherein said securing step comprises the steps of: securing said portable power source and said light source to one of a belt and a harness; and  
attaching said one of the belt and the harness to the patient.

25. The method of claim 18 or 19, wherein said providing step further comprises providing a focusing lens, wherein said focusing lens is selected from the group consisting of: a concave lens, a convex lens, and a totally internally reflecting lens; and

wherein said focusing lens is disposed between said light source and the proximal portion of said at least one optical fiber and is adapted to receive the quantity of light, transmit a portion of the quantity of light, and focus at least part of the portion of the quantity of light into the proximal portion of the optical fiber; and  
wherein said providing step optionally further comprises providing a parabolic mirror positioned adjacent to said light source so as to reflect a quantity of light from said light source onto the focusing lens.

26. The method of claim 25, wherein said light source is a plurality of LEDs and wherein said focusing lens is a totally internally reflective lens.

1 / 7

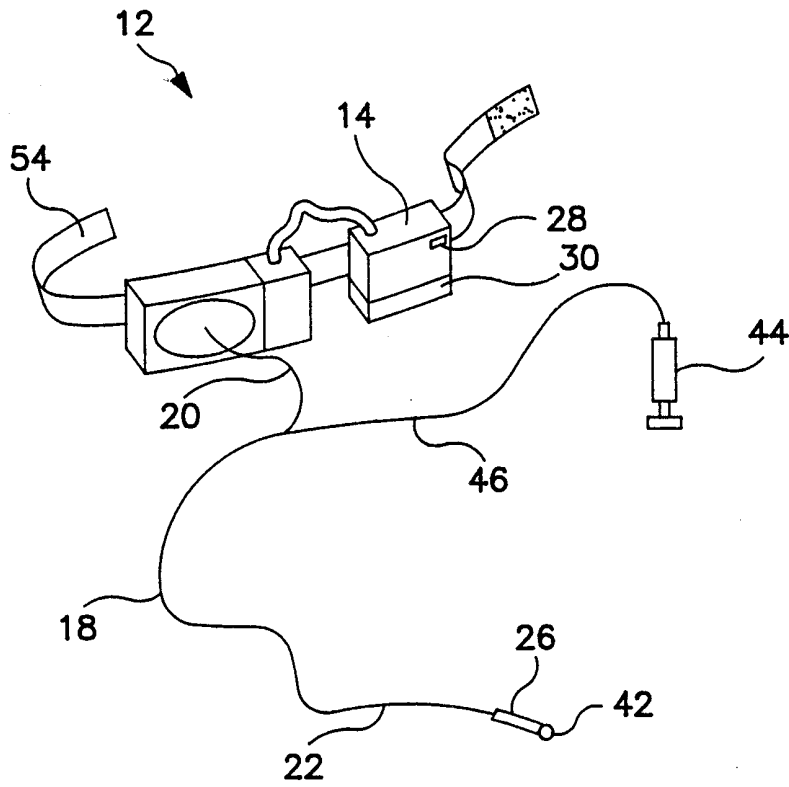

FIG. 1

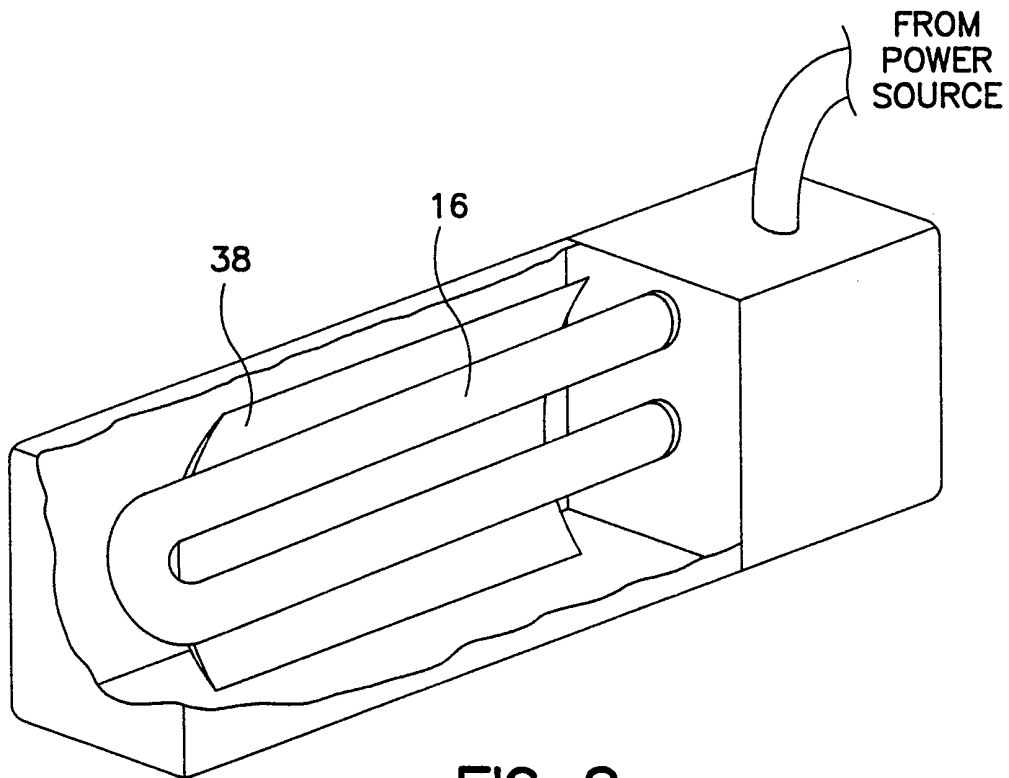

FIG. 2

2/7

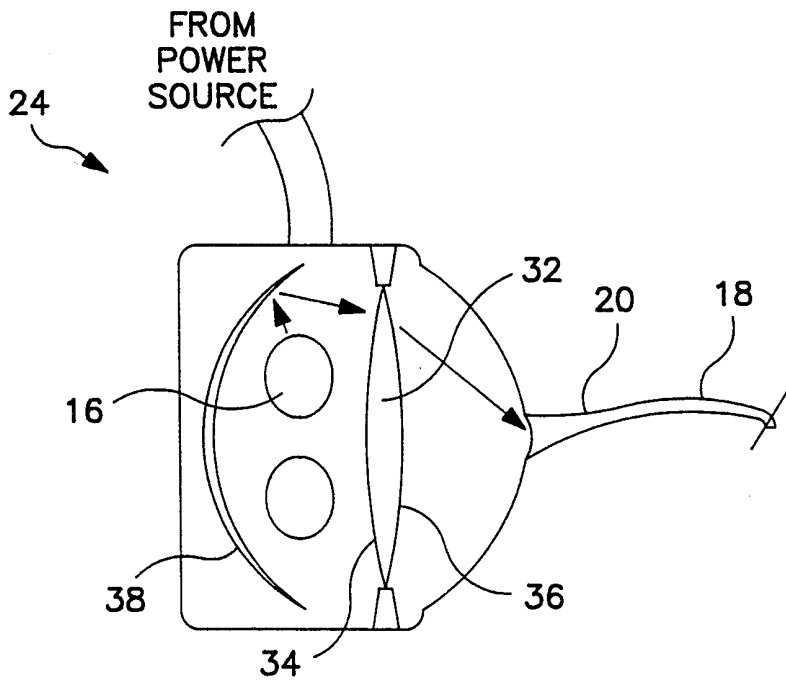

FIG. 3

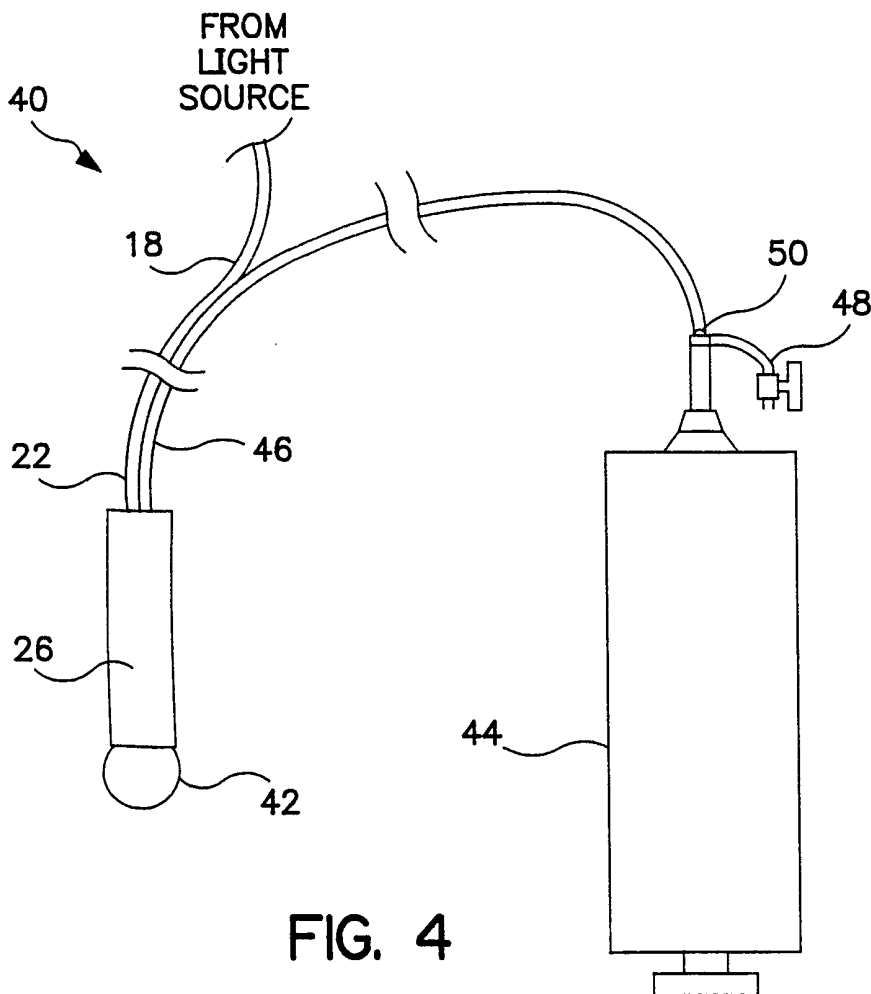

FIG. 4

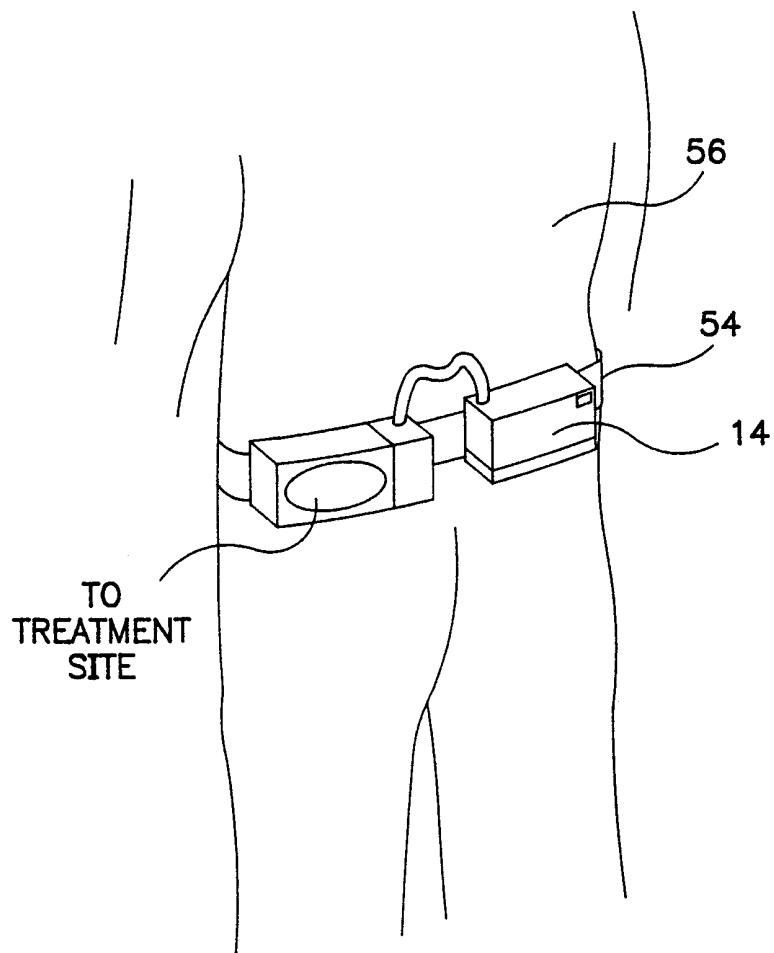
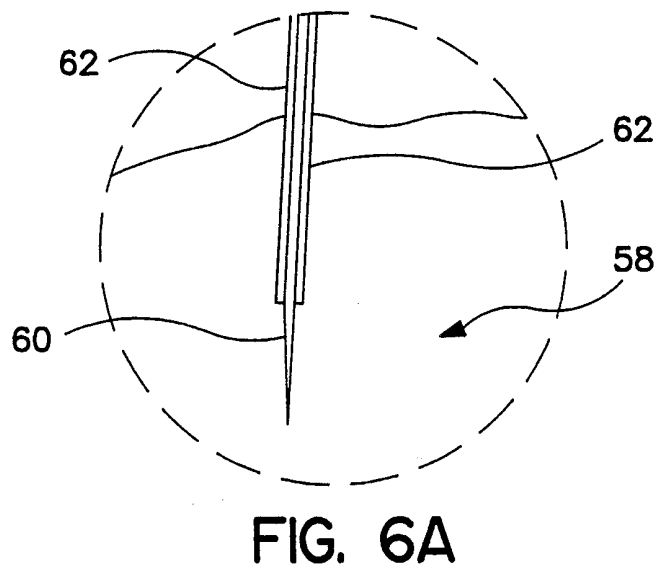
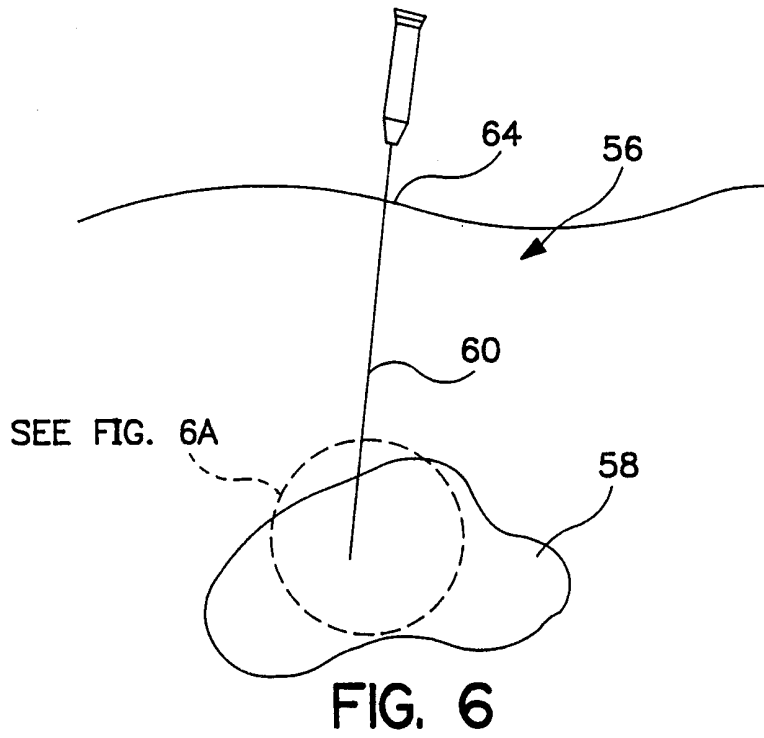

FIG. 5

4/7



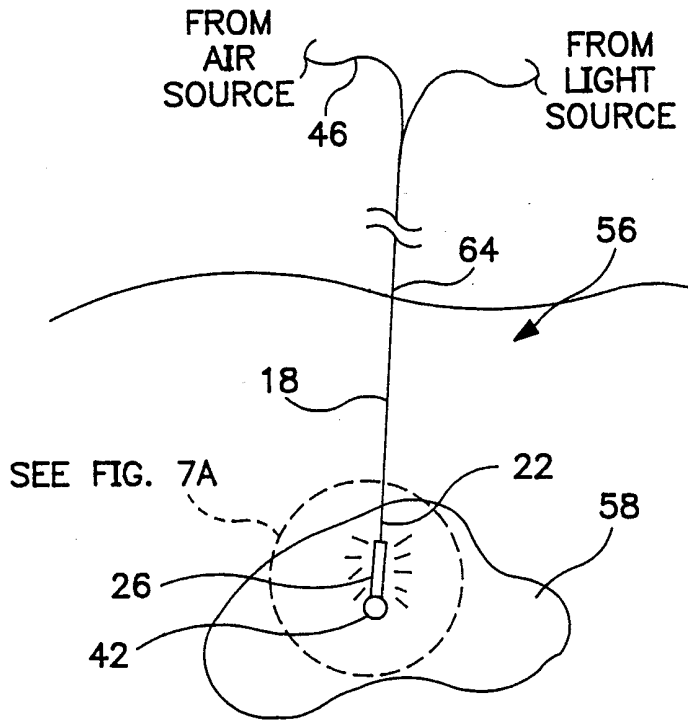

FIG. 7

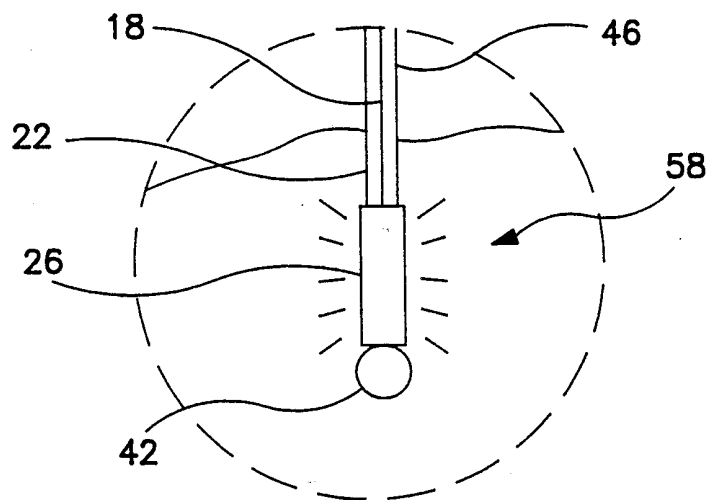

FIG. 7A



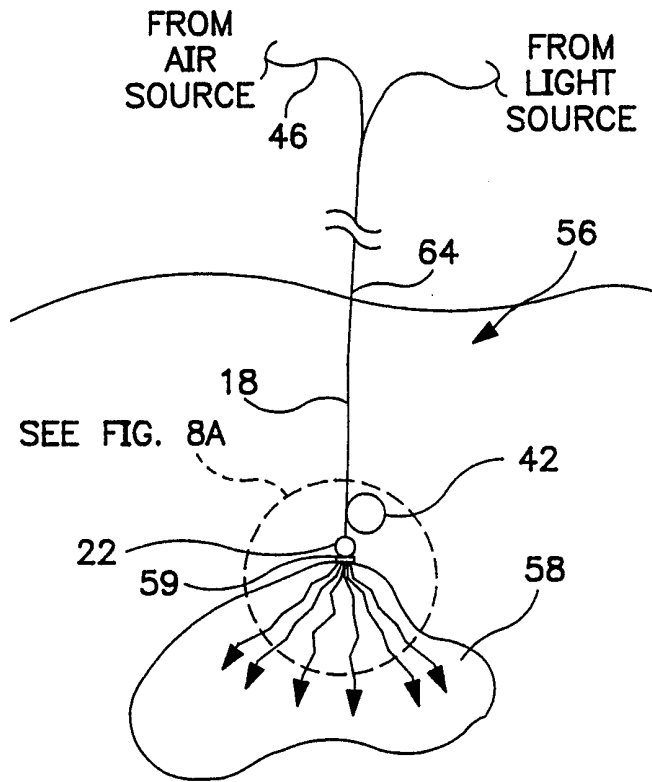

FIG. 8

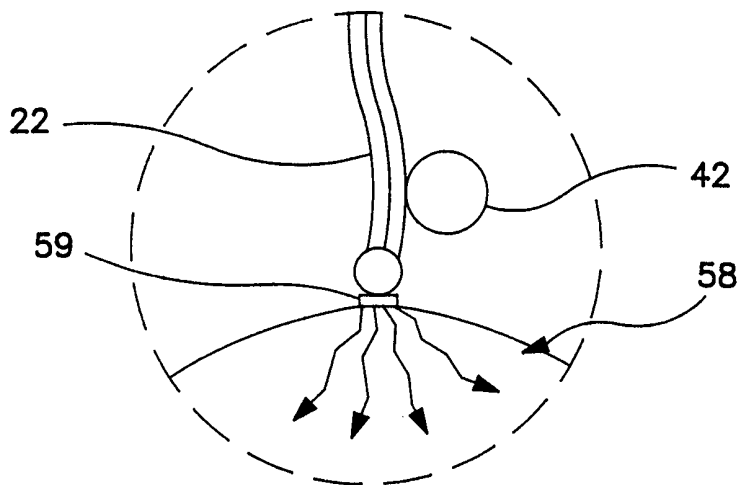

FIG. 8A

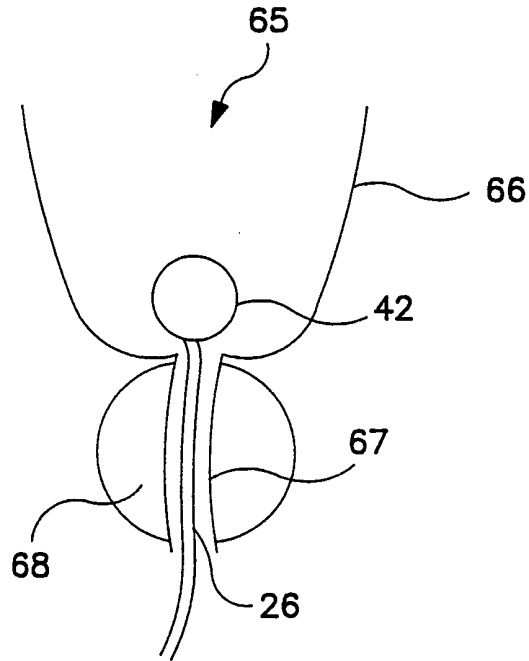

FIG. 9

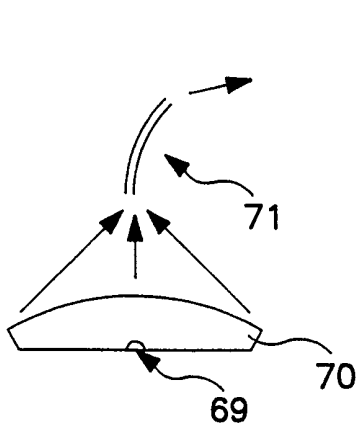

FIG. 10A

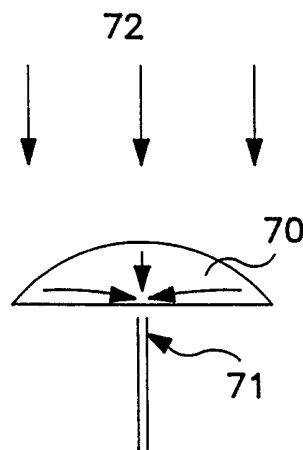

FIG. 10B

INTERNATIONAL SEARCH REPORT

International Application No  
PCT/US 00/00805

<b>A. CLASSIFICATION OF SUBJECT MATTER</b> IPC 7 A61N5/06		
According to International Patent Classification (IPC) or to both national classification and IPC		
<b>B. FIELDS SEARCHED</b>		
Minimum documentation searched (classification system followed by classification symbols) IPC 7 A61N A61B		
Documentation searched other than minimum documentation to the extent that such documents are included in the fields searched		
Electronic data base consulted during the international search (name of data base and, where practical, search terms used)		
<b>C. DOCUMENTS CONSIDERED TO BE RELEVANT</b>		
Category *	Citation of document, with indication, where appropriate, of the relevant passages	Relevant to claim No.
X	US 5 634 711 A (KAYSER ROY ET AL) 3 June 1997 (1997-06-03) column 1, line 21 - line 27 column 3, line 21 - line 37 column 4, line 31 - line 42	1,2,4-9
Y	-----	3,11-16
Y	US 5 843 143 A (WHITEHURST COLIN) 1 December 1998 (1998-12-01) column 2, line 36 - line 40 column 4, line 1 - line 14 column 4, line 49 - line 53 column 5, line 1 - line 11 ----- -/--	3
<input checked="" type="checkbox"/> Further documents are listed in the continuation of box C. <input checked="" type="checkbox"/> Patent family members are listed in annex.		
* Special categories of cited documents : *A* document defining the general state of the art which is not considered to be of particular relevance *E* earlier document but published on or after the international filing date *L* document which may throw doubts on priority claim(s) or which is cited to establish the publication date of another citation or other special reason (as specified) *O* document referring to an oral disclosure, use, exhibition or other means *P* document published prior to the international filing date but later than the priority date claimed *T* later document published after the international filing date or priority date and not in conflict with the application but cited to understand the principle or theory underlying the invention *X* document of particular relevance; the claimed invention cannot be considered novel or cannot be considered to involve an inventive step when the document is taken alone *Y* document of particular relevance; the claimed invention cannot be considered to involve an inventive step when the document is combined with one or more other such documents, such combination being obvious to a person skilled in the art. *&* document member of the same patent family		
Date of the actual completion of the international search  30 May 2000		Date of mailing of the international search report  07/06/2000
Name and mailing address of the ISA European Patent Office, P.B. 5818 Patentlaan 2 NL - 2280 HV Rijswijk Tel. (+31-70) 340-2040, Tx. 31 651 epo nl, Fax: (+31-70) 340-3016		Authorized officer  Petter, E

## INTERNATIONAL SEARCH REPORT

In. tional Application No  
PCT/US 00/00805

C.(Continuation) DOCUMENTS CONSIDERED TO BE RELEVANT		
Category °	Citation of document, with indication, where appropriate, of the relevant passages	Relevant to claim No.
Y	<p>US 5 445 608 A (CHEN JAMES C ET AL) 29 August 1995 (1995-08-29) column 4, line 42 - line 50 column 4, line 61 - line 68 column 10, line 24 - line 45 column 20, line 24 - line 28 column 23, line 43 -column 24, line 31; figure 17</p>	11-16
X	<p>US 5 766 222 A (PETIT MICHAEL G) 16 June 1998 (1998-06-16) column 3, line 12 - line 14 column 3, line 26 - line 33 column 3, line 64 -column 4, line 21; figures 3,4</p>	1,10,17
X	<p>US 5 474 528 A (MESEROL PETER M) 12 December 1995 (1995-12-12) column 9, line 9 - line 16</p>	1

# INTERNATIONAL SEARCH REPORT

...ernational application No.

PCT/US 00/00805

## Box I Observations where certain claims were found unsearchable (Continuation of Item 1 of first sheet)

This International Search Report has not been established in respect of certain claims under Article 17(2)(a) for the following reasons:

1.  Claims Nos.:  
because they relate to subject matter not required to be searched by this Authority, namely:
  
2.  Claims Nos.:  
because they relate to parts of the International Application that do not comply with the prescribed requirements to such an extent that no meaningful International Search can be carried out, specifically:
  
3.  Claims Nos.:  
because they are dependent claims and are not drafted in accordance with the second and third sentences of Rule 6.4(a).

## Box II Observations where unity of invention is lacking (Continuation of Item 2 of first sheet)

This International Searching Authority found multiple inventions in this international application, as follows:

1.  As all required additional search fees were timely paid by the applicant, this International Search Report covers all searchable claims.
  
2.  As all searchable claims could be searched without effort justifying an additional fee, this Authority did not invite payment of any additional fee.
  
3.  As only some of the required additional search fees were timely paid by the applicant, this International Search Report covers only those claims for which fees were paid, specifically claims Nos.:
  
4.  No required additional search fees were timely paid by the applicant. Consequently, this International Search Report is restricted to the invention first mentioned in the claims; it is covered by claims Nos.:

Remark on Protest

- The additional search fees were accompanied by the applicant's protest.
- No protest accompanied the payment of additional search fees.

# INTERNATIONAL SEARCH REPORT

Information on patent family members

International Application No

PCT/US 00/00805

Patent document cited in search report	Publication date	Patent family member(s)	Publication date
US 5634711 A	03-06-1997	US 5420768 A	30-05-1995
		AU 7737894 A	03-04-1995
		CA 2149339 A	23-03-1995
		WO 9507731 A	23-03-1995
US 5843143 A	01-12-1998	GB 2272278 A	11-05-1994
		EP 0618824 A	12-10-1994
		WO 9409850 A	11-05-1994
US 5445608 A	29-08-1995	AU 674251 B	12-12-1996
		AU 7357594 A	14-03-1995
		CA 2147142 A	23-02-1995
		EP 0680363 A	08-11-1995
		JP 8505803 T	25-06-1996
		WO 9505214 A	23-02-1995
US 5766222 A	16-06-1998	US 6027524 A	22-02-2000
US 5474528 A	12-12-1995	WO 9704836 A	13-02-1997