



US 20030192494A1

(19) **United States**

(12) **Patent Application Publication**
Hendriksma

(10) **Pub. No.: US 2003/0192494 A1**

(43) **Pub. Date: Oct. 16, 2003**

(54) **TWO-STEP FINGER FOLLOWER ROCKER ARM**

(52) **U.S. Cl. 123/90.16**

(76) **Inventor: Nick J. Hendriksma, Grand Rapids, MI (US)**

(57) **ABSTRACT**

Correspondence Address:

Patrick M. Griffin, Esq.
Delphi Technologies, Inc.
Mail Code 480410202
P.O. Box 5052
Troy, MI 48007 (US)

(21) **Appl. No.: 10/306,758**

(22) **Filed: Nov. 27, 2002**

Related U.S. Application Data

(63) **Continuation-in-part of application No. 10/121,720, filed on Apr. 12, 2002.**

Publication Classification

(51) **Int. Cl.⁷ F01L 1/34**

A two-step finger follower rocker arm assembly including a follower body having a socket at a first end for engaging a hydraulic lash adjuster and a pad at an opposite end for engaging a valve stem. A passage through the follower body in the direction of actuation by an engine cam lobe is slidably receivable of a slider member for variably engaging a central cam lobe, preferably a high-lift lobe. A latch member driven by a piston selectively locks the slider member to the follower body such that the follower follows the motion of the central cam lobe. When the latch member is disengaged from the slider member, the slider member slides within the follower body. The body is provided with a stud extending from an upper surface thereof and formed as an extension of the passage for supporting the slider over a greater length thereof such that a counter-torque moment on the slider in the passage is reduced.

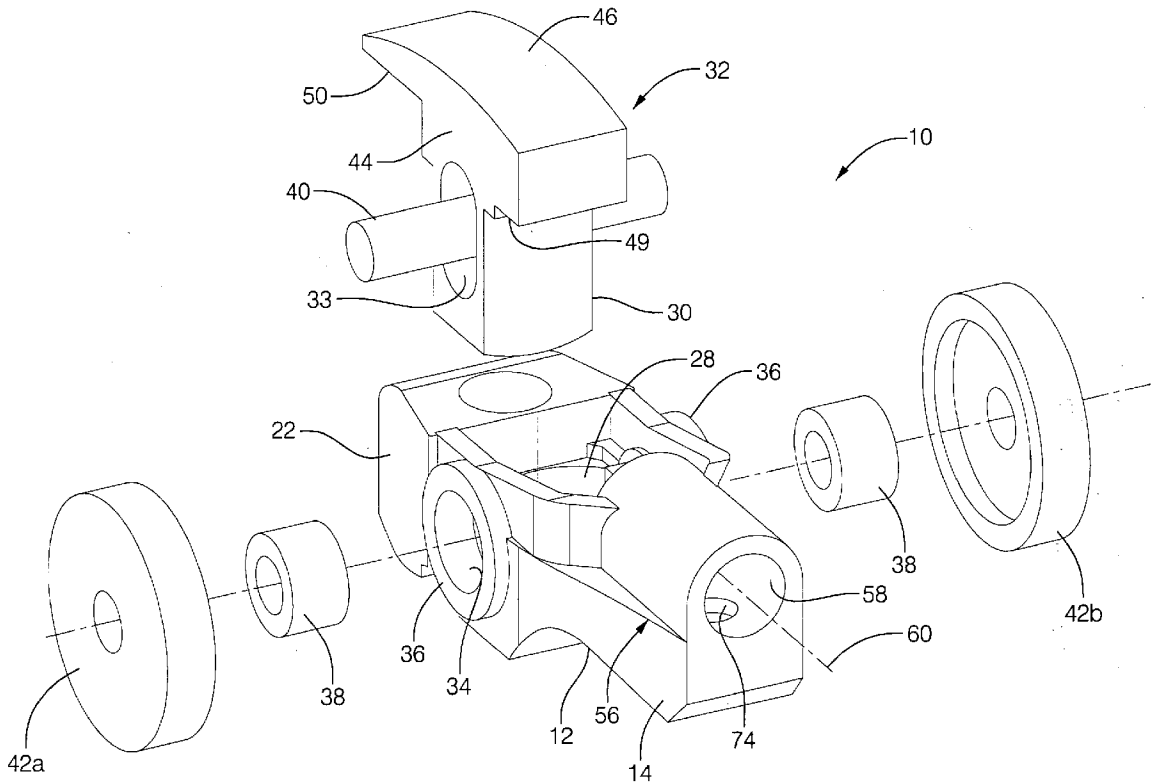

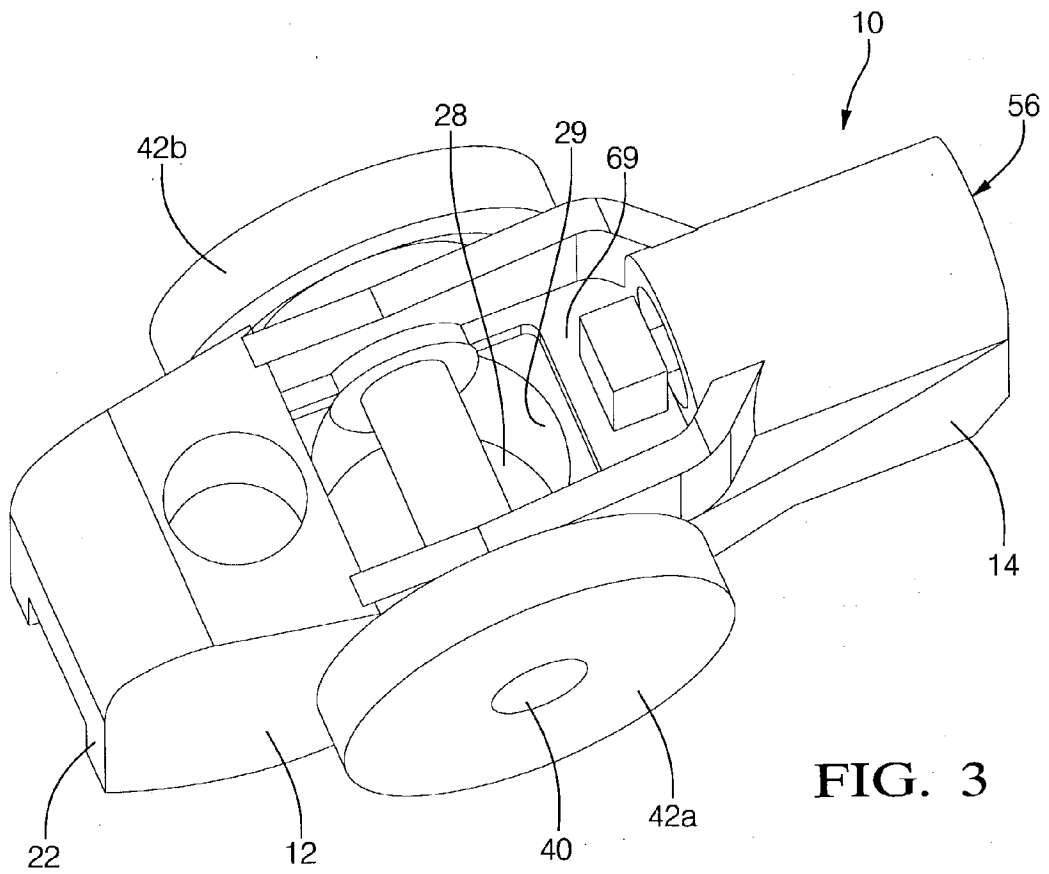
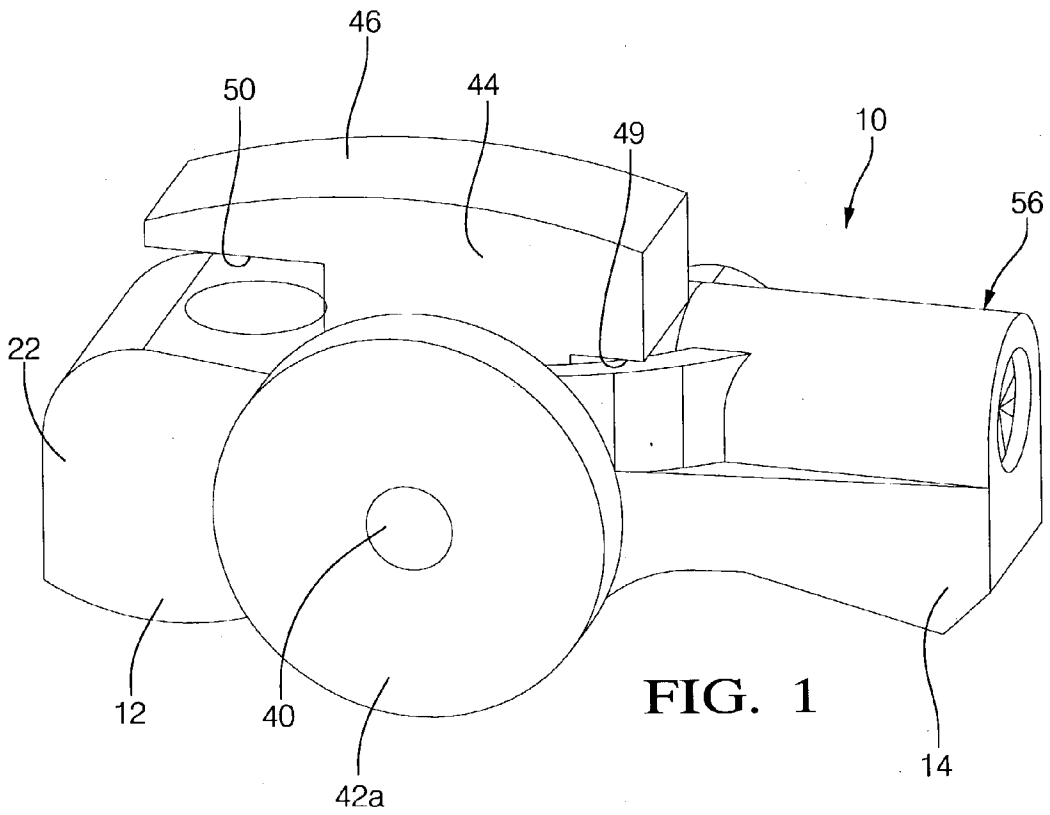

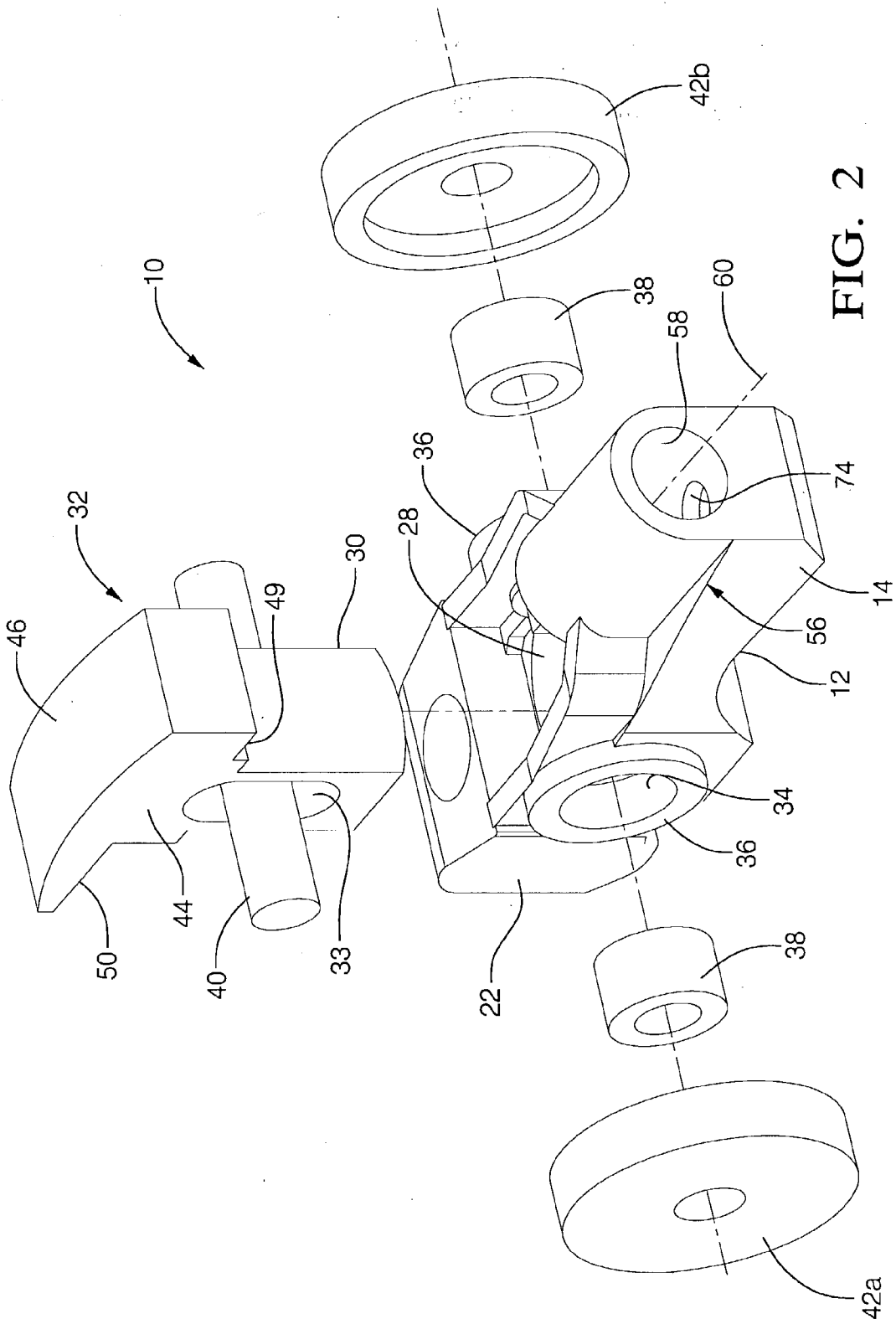

FIG. 2

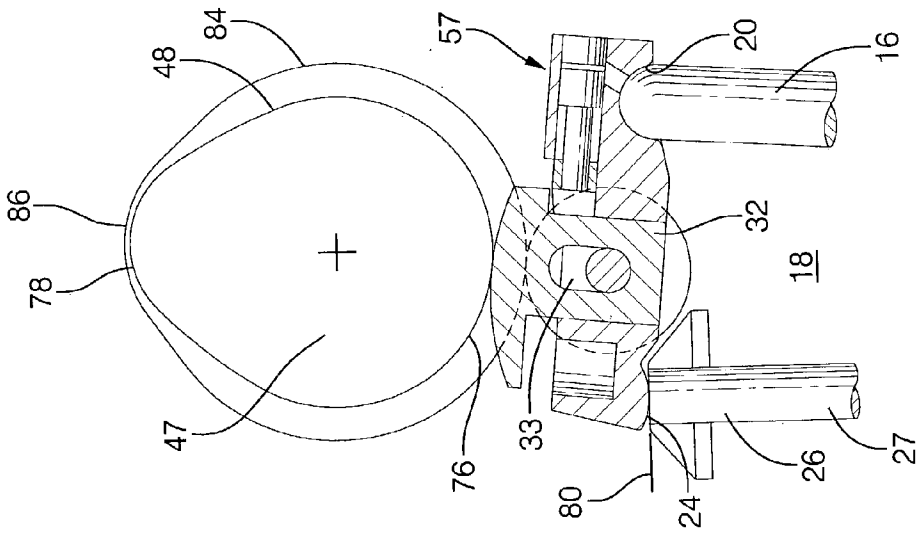

FIG. 4

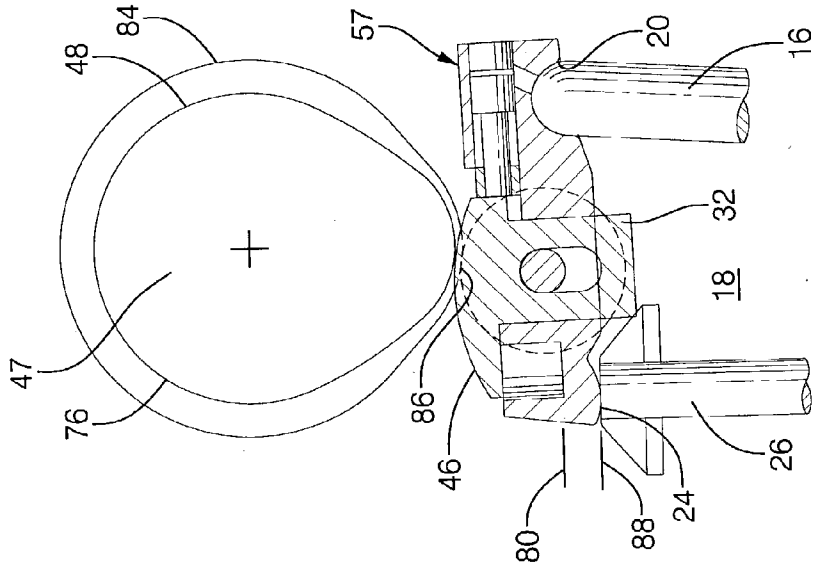

FIG. 5

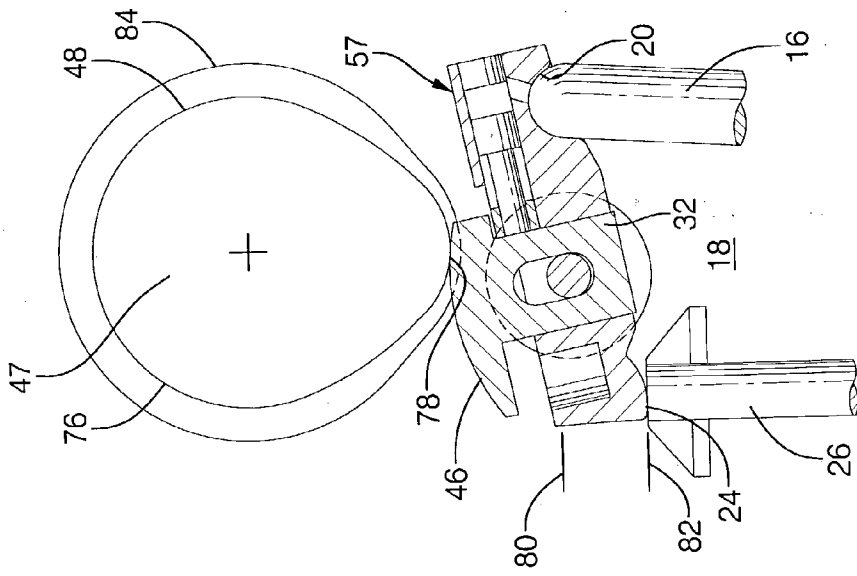

FIG. 6

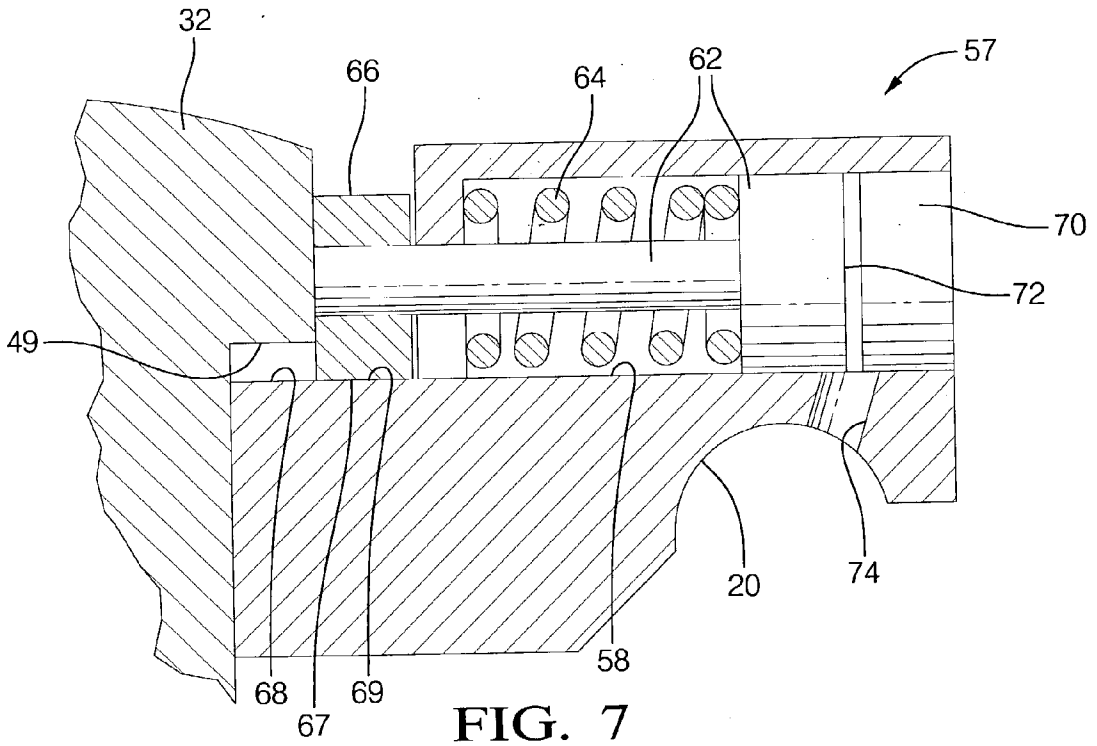

FIG. 7

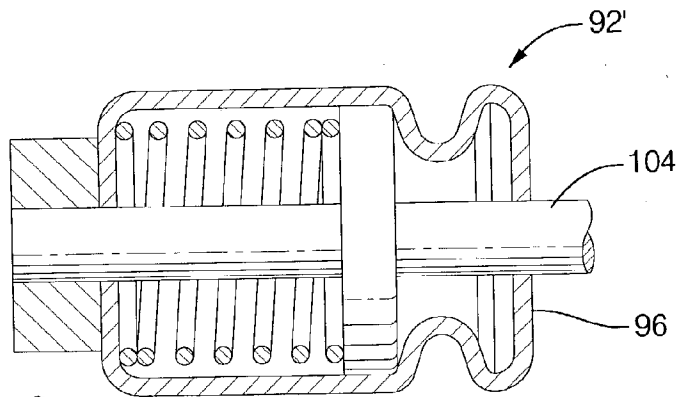

FIG. 8

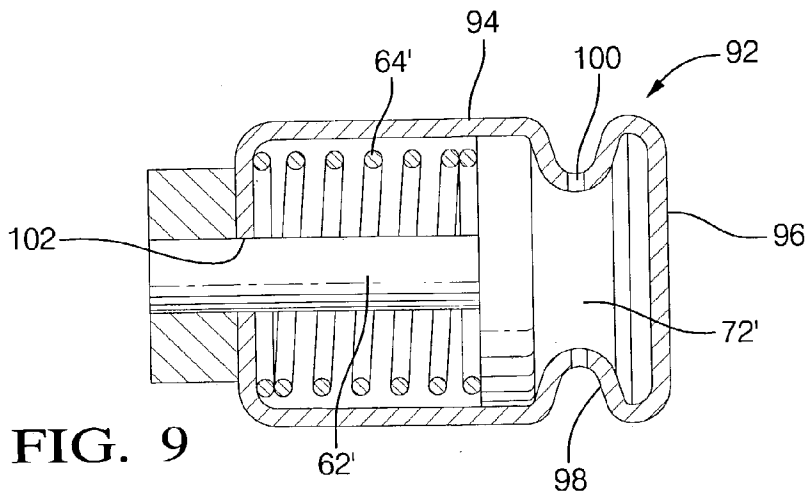

FIG. 9

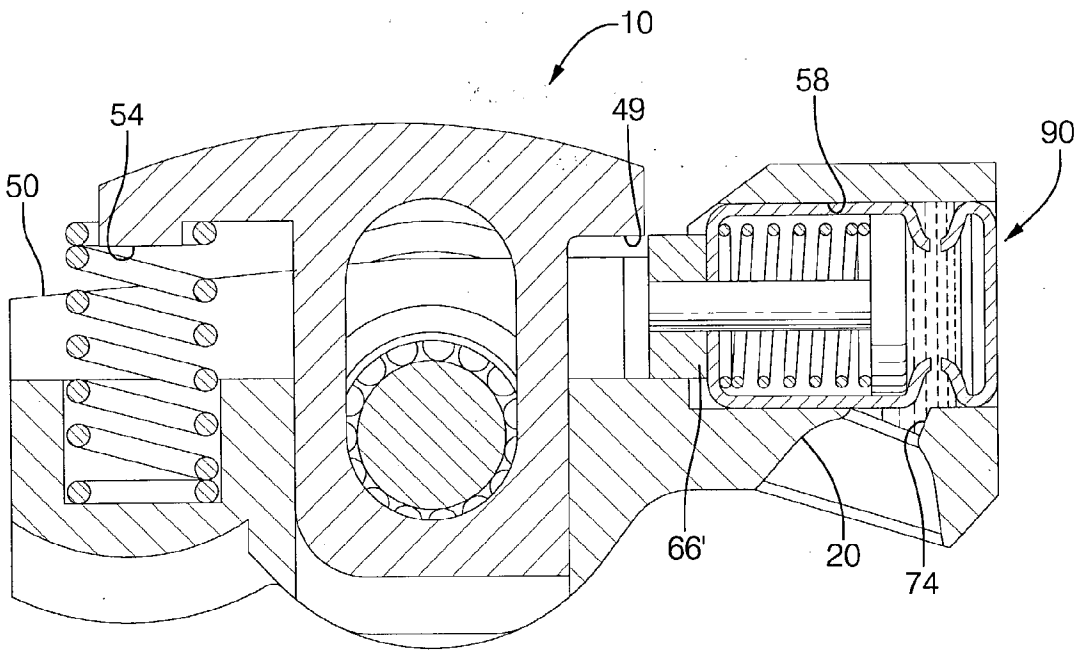

FIG. 10

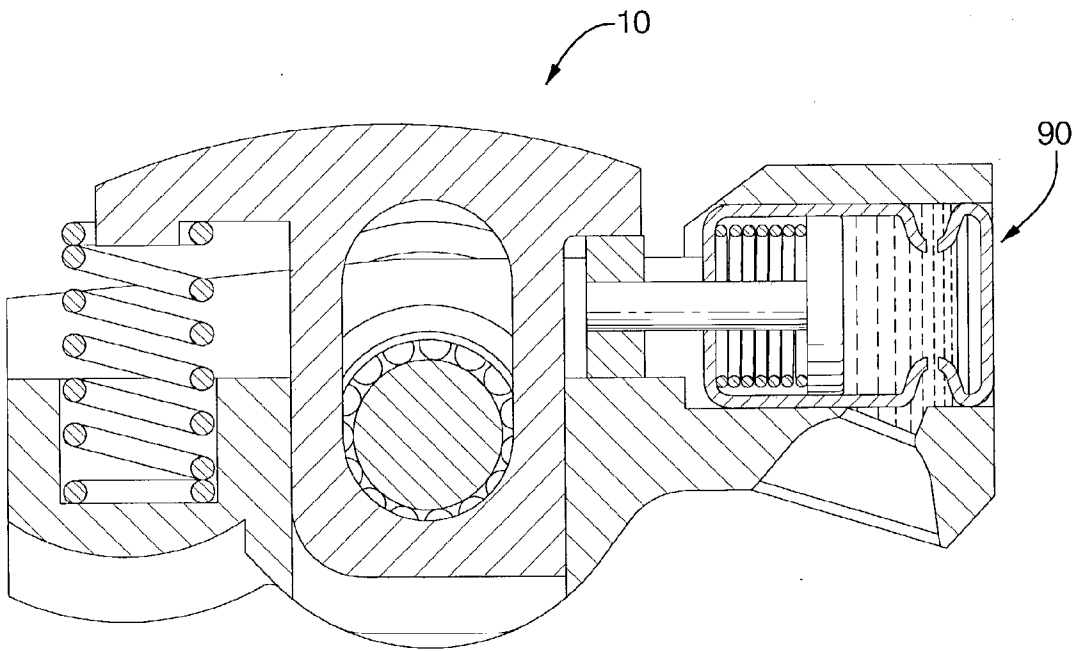

FIG. 11

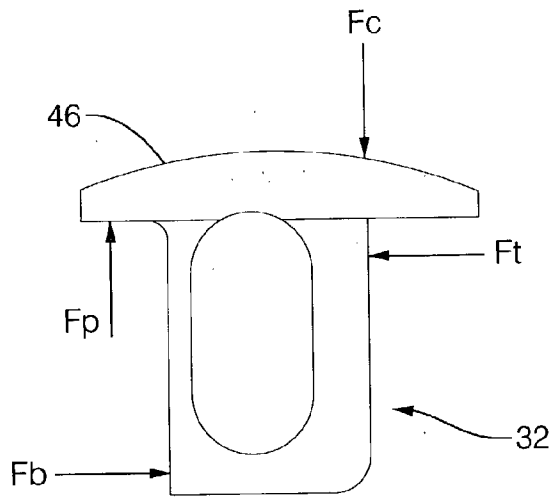

FIG. 12

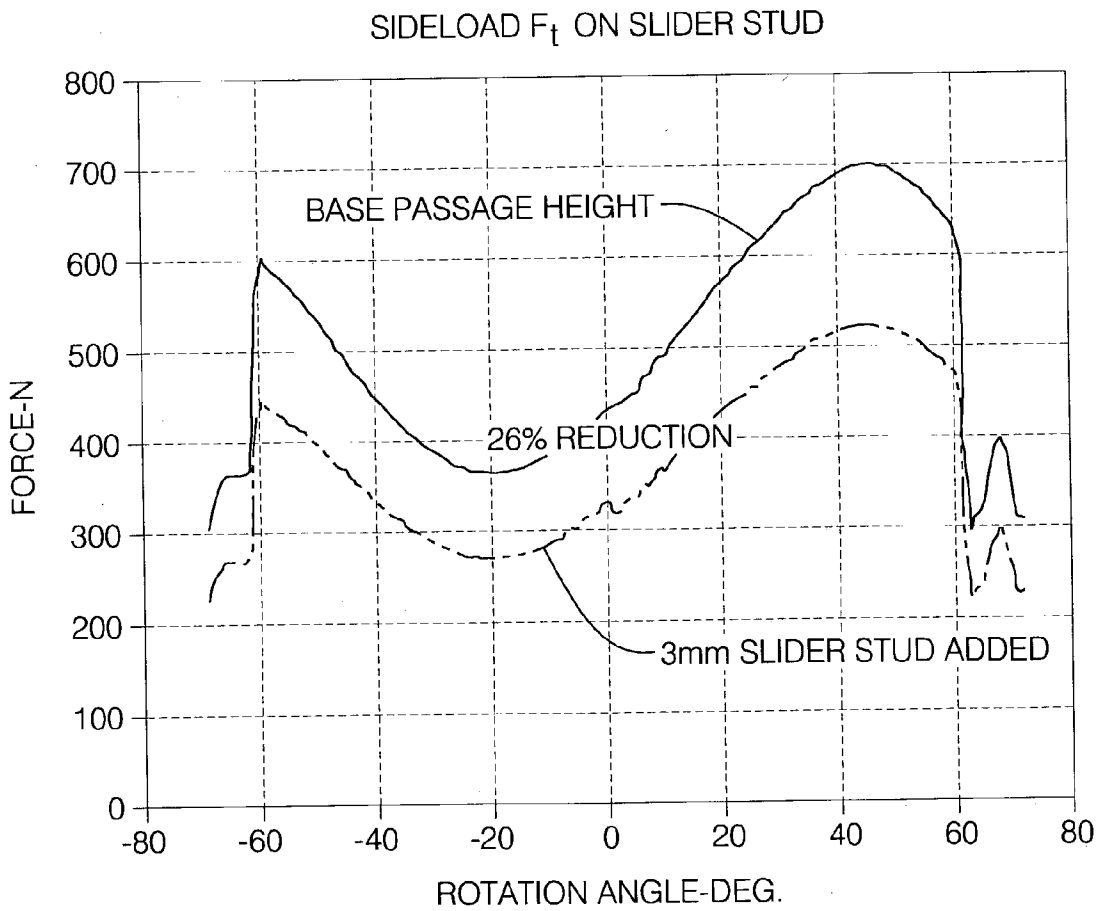
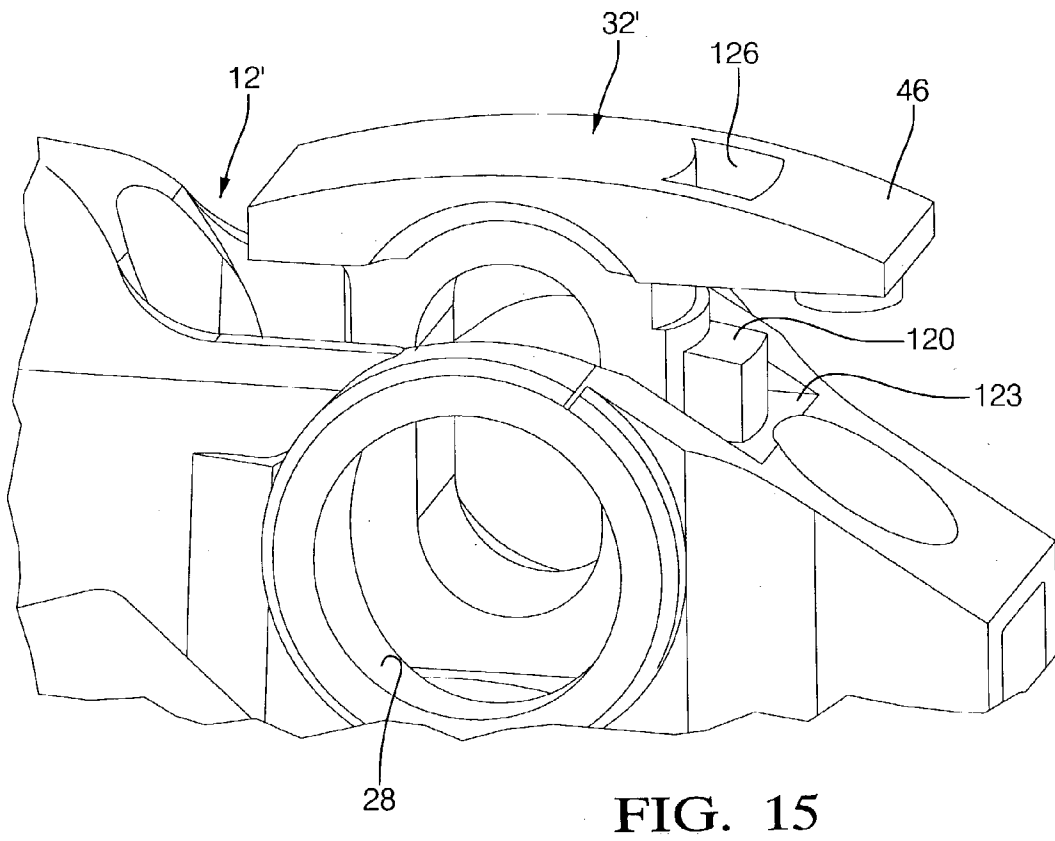
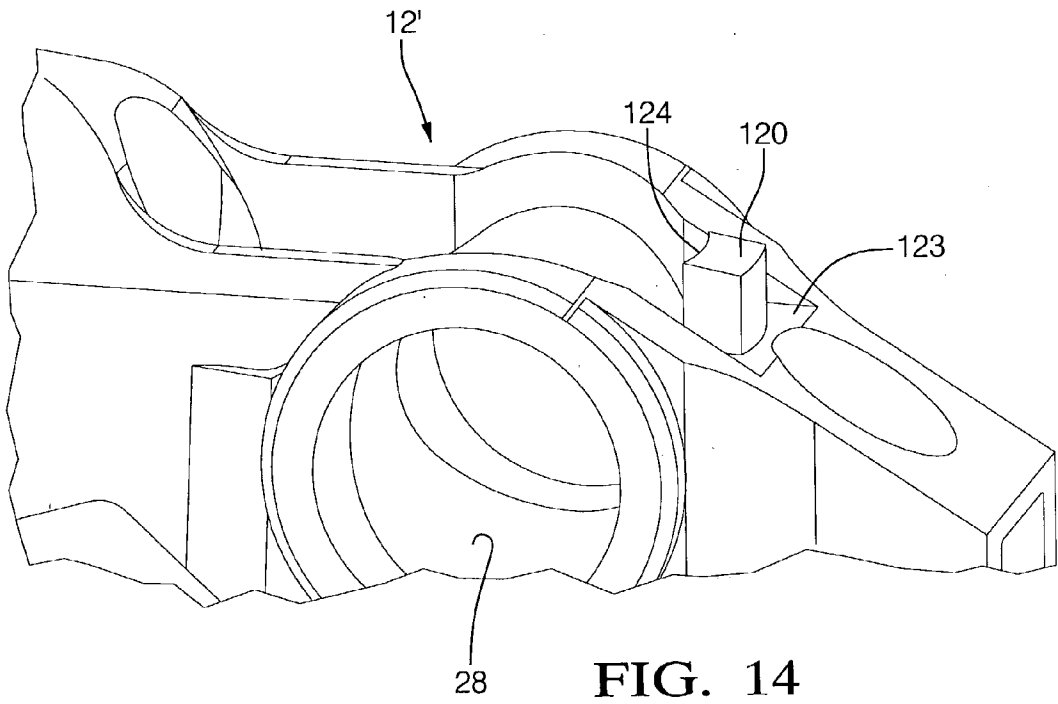

FIG. 13



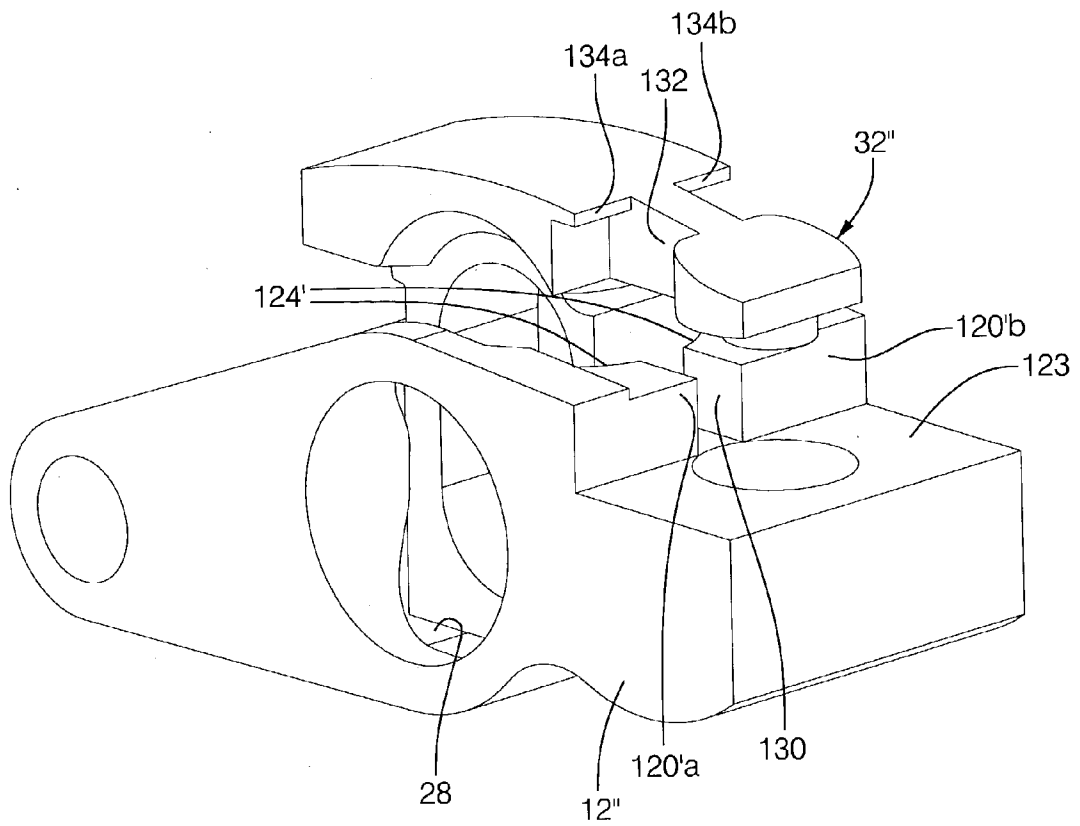

FIG. 16

TWO-STEP FINGER FOLLOWER ROCKER ARM

RELATIONSHIP TO OTHER APPLICATIONS AND PATENTS

[0001] The present application is a Continuation-In-Part of a pending U.S. patent application Ser. No. 10/121,720, filed Apr. 12, 2002.

TECHNICAL FIELD

[0002] The present invention relates to mechanisms for altering the actuation of valves in internal combustion engines; more particularly, to finger follower type rocker arms having means for changing between high and low or no valve lifts; and most particularly, to a two-step finger follower type rocker arm having a slider member disposed in a passage in a finger follower body for sliding motion in the direction of lift between high and low positions and having a locking pin operative in an orthogonal bore in the finger follower body for latching and unlatching the slider member and the finger follower body to shift between high lift and low lift modes.

BACKGROUND OF THE INVENTION

[0003] Variable valve activation (VVA) mechanisms for internal combustion engines are well known. It is known to be desirable to lower the lift, or even to provide no lift at all, of one or more valves of a multiple-cylinder engine, especially intake valves, during periods of light engine load. Such deactivation can substantially improve fuel efficiency.

[0004] Various approaches have been disclosed for changing the lift of valves in a running engine. One known approach is to provide an intermediary cam follower arrangement which is rotatable about the engine camshaft and is capable of changing both the valve lift and timing, the cam shaft typically having both high-lift and low-lift lobes for each such valve. Such an arrangement can be complicated and costly to manufacture and difficult to install onto a camshaft during engine assembly.

[0005] Another known approach is to provide a deactivation mechanism in the hydraulic lash adjuster (HLA) upon which a cam follower rocker arm pivots. Such an arrangement is advantageous in that it can provide variable lift from a single cam lobe by making the HLA either competent or incompetent to transfer the motion of the cam eccentric to the valve stem. A shortcoming of providing deactivation at the HLA end of a rocker arm is that, because the cam lobe actuates the rocker near its longitudinal center point, the variation in lift produced at the valve-actuating end can be only about one-half of the extent of travel of the HLA deactivation mechanism.

[0006] Still another known approach is to provide a deactivation mechanism in the valve-actuating end of a rocker arm cam follower (opposite from the HLA pivot end) which locks and unlocks the valve actuator portion from the follower body. Unlike the HLA deactivation approach, this approach typically requires both high-lift and low-lift cam lobes to provide variable lift.

[0007] It is a principal object of the present invention to provide a simplified variable valve lift apparatus.

[0008] It is a further object of the invention to provide an increased range of motion between a high lift and a low lift position of an engine valve.

SUMMARY OF THE INVENTION

[0009] Briefly described, a two-step finger follower rocker arm assembly in accordance with the invention includes an elongate, rigid follower body having a socket at a first end for engaging a conventional hydraulic lash adjuster as a pivot means, and having an arcuate pad at a second and opposite end for engaging a valve stem or lifter means. A passage through the follower body in the direction of actuation by an engine cam lobe is slidably receivable of a reciprocating slider member for variably engaging a central cam lobe, preferably a high-lift lobe. A transverse bore in the follower body intersects the passage. A slot is provided in the slider member, and an elongate shaft extends through the bore in the body and through the slot in the slider member such that the maximum length of travel of the slider member in the passage is limited by the length of the clearance between the shaft and the slot. Outboard of the follower body, the shaft is provided on either side of the body with first and second lateral roller followers, preferably rotatably mounted in bearings on the shaft, for variably engaging first and second lateral cam lobes, preferably low-lift lobes, flanking the central cam lobe. A lost-motion spring urges the slider member into contact with the central lobe, and the hydraulic lash adjuster urges the lateral rollers into contact with the lateral lobes. A transverse locking pin can selectively engage and lock the slider member to the follower body such that the follower follows the motion of the central cam lobe. When the locking pin is disengaged from the slider member, the member slides within the passage formed in the follower body, allowing the lateral rollers to engage and follow the lateral lobes. Preferably, the central lobe is a high-lift lobe and the lateral lobes are low-lift lobes. Preferably, the locking pin is provided as a pre-assembled cartridge unit. To reduce undesirable torque and resulting wear on the slider in the passage, caused by sliding action of the slider against the central cam lobe, a wall of the passage preferably is extended to increase the resistive torque moment of the slider in the passage.

BRIEF DESCRIPTION OF THE DRAWINGS

[0010] These and other features and advantages of the invention will be more fully understood and appreciated from the following description of certain exemplary embodiments of the invention taken together with the accompanying drawings, in which:

[0011] **FIG. 1** is an isometric view from the front of a two-step finger follower rocker arm assembly in accordance with the invention;

[0012] **FIG. 2** is an exploded isometric view of the rocker arm assembly shown in **FIG. 1**;

[0013] **FIG. 3** is an isometric view from above of the rocker arm assembly shown in **FIG. 1**, the slider member being omitted for illustration;

[0014] **FIG. 4** is an elevational cross-sectional view of the rocker arm assembly shown in **FIG. 1**, installed schematically in an internal combustion engine and having the associated valve closed, the locking pin unlocked, and the slider member on the base circle portion of the central cam lobe;

[0015] **FIG. 5** is an elevational cross-sectional view like that shown in **FIG. 4**, showing the locking pin still unlocked,

the lateral roller followers on the nose of the lateral cam lobes, and the valve opened to a low-lift position;

[0016] FIG. 6 is an elevational cross-sectional view like that shown in FIG. 4, showing the locking pin in locked position in the slider member, the nose of the central cam lobe on the slider member, and the valve opened to a high-lift position;

[0017] FIG. 7 is an elevational cross-sectional view of a first embodiment of a locking pin assembly in accordance with the invention;

[0018] FIG. 8 is an elevational cross-sectional view of a second embodiment of a locking pin assembly, showing a cartridge pin subassembly having a piston extension for mechanical actuation of the locking pin;

[0019] FIG. 9 is a view like that shown in FIG. 8, showing a cartridge pin subassembly without the piston extension, as would be configured for hydraulic actuation of the locking pin;

[0020] FIG. 10 is an elevational cross-sectional view of a two-step finger follower in accordance with the invention, including the cartridge pin subassembly shown in FIG. 8, the pin and slider member being in the unlocked position;

[0021] FIG. 11 is an elevational cross-sectional view like that shown in FIG. 10, showing the pin and slider member in the locked position;

[0022] FIG. 12 is a schematic cross-sectional diagram of a slider element showing imposed and resistive torque moments;

[0023] FIG. 13 is a graph showing beneficial side-load force reduction by extending the length of the slider passage in the follower body;

[0024] FIG. 14 is an isometric view of the follower body showing a first embodiment of a passage extender stud in accordance with the invention;

[0025] FIG. 15 is an isometric view like that shown in FIG. 14, showing a first embodiment of a slider installed in the follower body and having a central cutout to accommodate the passage extender when in low-lift mode; and

[0026] FIG. 16 is an isometric view of a second embodiment of passage extension means, showing a second embodiment of a passage extender stud and a second embodiment of a slider installed in the follower body and having a pair of peripheral cutouts to accommodate the passage extender stud when in low-lift mode.

DESCRIPTION OF THE PREFERRED EMBODIMENTS

[0027] Referring to FIGS. 1 through 6, a two-step finger follower rocker arm assembly 10 in accordance with the invention includes a follower body 12 having a first end 14 having means for receiving the head of a hydraulic lash adjuster 16 for pivotably mounting assembly 10 in an engine 18. The receiving means is preferably a spherical socket 20, as shown in FIGS. 4-6. A second and opposite end 22 of follower body 12 is provided with a pad 24, preferably arcuate, for interfacing with and actuating a valve stem 26 of gas valve 27. Body 12 is provided with a passage 28 therethrough between socket 20 and pad 24, passage 28

being generally cylindrical and having a sliding surface 29 for slidably receiving a partially-cylindrical mating sliding surface 30 of a slider member 32 having a longitudinal slot 33 therein. Body 12 is further provided with a first bore 34 transverse of passage 28, ending in bosses 36 for receiving roller bearings 38 for rotatably supporting a shaft 40 extending through bore 34 and slot 33 to slidably retain slider member 32 in passage 28. First and second lateral follower rollers 42a,b are mounted on opposite ends, respectively, of shaft 40.

[0028] Slider member 32 further includes an actuating portion 44 having an arcuate outer surface 46 for engaging a central cam lobe 48 of an engine camshaft 47. Portion 44 extends toward first and second ends 14,22 of 12 to define, respectively, a latching surface 49 and a spring seat 50. Second end 22 is provided with a well 52 for receiving a lost-motion spring 54 disposed between end 22 and spring seat 50 (spring 54 shown in FIG. 10 but omitted from the other drawings for clarity).

[0029] First end 14 is further provided with a latching mechanism 56 for engaging and locking slider member 32 at its most outward extreme of motion in passage 28. Mechanism 56 comprises a stepped second bore 58 in body 12 and having an axis 60 intersecting passage 28, preferably orthogonally, bore 58 being preferably cylindrical.

[0030] Referring to FIGS. 4 through 7, latching means 57 in mechanism 56 includes a piston 62 biased outwards in bore 58 by a return spring 64 and extending toward slider member 32 to support a latch member 66 which may slide along a slide surface 68 in body 12. Bore 58 is closed by a plug 70, forming a hydraulic chamber 72 in communication via passage 74 with socket 20. Pressurized oil may be supplied to chamber 72 in known fashion from HLA 16, upon command from an engine control module (not shown), to cause piston 62 to become hydraulically biased toward slider member 32. When such biasing occurs, to overcome the counter-bias of return spring 64, arcuate surface 46 being engaged on the base circle portion 76 of central cam lobe 48, latch member 66 is urged axially into latching and locking engagement with latching surface 49. As shown in FIG. 6, when cam lobe 48 rotates to engage nose portion 78 with surface 46, valve stem 26 is actuated from a zero lift position 80 to a high lift position 82.

[0031] Still referring to FIGS. 4 through 6, central cam lobe 48 is flanked by first and second lateral cam lobes 84 (only one visible in FIGS. 4-6) for selectively engaging first and second lateral follower rollers 42a,b, respectively. When the engine control module determines, in known fashion from various engine operating parameters, that a low-lift condition is desired, oil pressure is no longer supplied to chamber 72, allowing return spring 64 to again bias piston 62 and associated latch member 66 away from slider member 32. When cam lobe 48 rotates to place surface 46 on base circle portion 76 again, piston 62 unlatches latch member 66 and slider member 32 is again free to slide in passage 28. When the camshaft again rotates to place nose 78 on surface 46, member 32 is depressed into body 12, allowing noses 86 on lateral cam lobes 84 to be engaged by rollers 42a,b, as shown in FIG. 5, thus displacing valve stem 26 from zero lift position 80 to a low-lift position 88. As long as oil pressure is withheld from chamber 72, latching mechanism 56 remains disengaged from slider member 32, and assembly 10 functions as a low-lift rocker.

[0032] As shown in FIGS. 3 and 7, latch member 66 includes flatted bottom surface 67 for slidably engagement with flatted portion 69 of slider surface 68. Thus, when latch member 66 is in position to lock slider member 32, the downward force exerted on the slider member is supported vertically by latch member 66 and slider surface 68 and is not translated torsionally through piston 62.

[0033] Of course, it will be seen by those of skill in the art that the dimensions of the lateral cam lobes and lateral follower rollers may be configured to provide any desired degree of lift to valve stem 26 in a range between positions 80 and 88.

[0034] Referring to FIGS. 8 through 11, another embodiment 90 is shown for a latching mechanism 56 in accordance with the invention. Embodiment 90 comprises a latching cartridge 92 which may be inserted into bore 58 and which is preferably and conveniently pre-assembled as a sub-assembly, thereby greatly simplifying the overall assembly of follower 10. Cartridge 92 includes a body 94, preferably tubular and closed at outer end 96 and sized to be press-fitted into bore 58, thereby eliminating the need for plug 70. Preferably, body 94 is constricted 98 to separate piston 62' from end 96, thereby providing a hydraulic chamber 72' within the cartridge. Constriction 98 is perforated 100 to allow hydraulic communication with passage 74 and socket 20. Body 94 is partially closed at inner end 102 to retain return spring 64' and provide guidance for piston 62' in driving latch member 66' into (FIG. 11) and out of (FIG. 10) engagement with latching surface 49.

[0035] Referring to FIG. 8, a variation 92' of cartridge 92 is provided with a piston extension 104 slidably extending through outer end 96 for engagement by mechanical or electromechanical actuation means (not shown), for example, a conventional solenoid actuator, in place of the previously-discussed hydraulic actuation.

[0036] Referring to FIGS. 5, 7, and 12, rotation of eccentric nose portion 78 of central cam lobe 48 against slider surface 46 exerts a force F_c against the slider, which is resisted by a force F_p generated by latch member 66 in locked position. As the two forces are not directly opposed, a torque moment is imposed on slider member 32, creating a resistive counter-torque moment comprising forces F_b and F_t . These forces can cause wear of slider element 32 and the walls of passage 28 and cause stress on these components as well. The magnitude of these counter forces is a function of the distance between them as taken along the longitudinal dimension of slider member 32.

[0037] Referring to FIG. 13, it is seen that significant reduction in F_t (and, of course, F_b) can be obtained by extending the distance between F_b and F_t , for example, by about 3 mm, beneficially reducing the wear rates of slider element 32 and walls of passage 28 and contact stress therebetween.

[0038] Referring to FIGS. 14 and 15, in a first improved embodiment of a follower body 12', a passage extender stud 120 extends upwards from upper surface 123 of body 12' and has a face 124 that is an extension of the inner surface of passage 28. Thus, the surface of passage 28 supportive of slider member 32 is lengthened to reduce the torque moment (sideload force) as shown in FIG. 13. Preferably, stud 120 is about 3 mm in length. To permit slider member 32 to be

depressed normally in passage 28 when latch mechanism 56 is disengaged, a cutout passage 126 is provided in an improved slider member 32', preferably having about the same cross-sectional shape as stud 120, so that stud 120 may pass to its necessary extent into slider member 32 during lost-motion movement of the slider within passage 28.

[0039] Cutout passage 126 opens onto surface 46, and high-lift cam lobe passes over it only during low-lift (disengaged) operation of the lifter when contact loads are at a minimum. Referring to FIG. 16, in a second embodiment of a follower body 12" passage extender studs 120'a,b extend upwards from upper surface 123 of body 12". Extender studs 120'a,b are axially separated by an opening 130 between studs 120'a and 120'b. The studs have faces 124' that are extensions of the inner surface of passage 28. Thus the surface of passage 28 supportive of slider member 32 is lengthened. Preferably, studs 120'a,b are about 3 mm in length. To permit improved slider member 32" to be depressed normally in passage 28 when latch mechanism 56 is disengaged, opening 130 receives flange 132; further, member 32" is provided with lateral cutouts 134a,134b for receiving studs 120'a,120'b during lost-motion movement of the slider into passage 28.

[0040] While the invention has been described by reference to various specific embodiments, it should be understood that numerous changes may be made within the spirit and scope of the inventive concepts described. Accordingly, it is intended that the invention not be limited to the described embodiments, but will have full scope defined by the language of the following claims.

What is claimed is:

1. A two-step finger follower rocker arm assembly for variably activating a gas valve in an internal combustion engine having a camshaft having a central lobe and at least one lateral lobe, comprising:

- a) a follower body having means for engaging said engine at a first end of said body and having means for engaging a valve stem of said gas valve at a second end of said body and having a passage formed in said body between said first end and said second end and having an upper surface at the terminus of said passage adjacent said camshaft;
- b) a slider member slidably disposed in said passage and having an outer surface for engaging said central lobe of said camshaft, and having a latching surface, and having a first sliding surface for engaging a second sliding surface of said passage;
- c) latching means disposed in said follower body for latching said slider member to said body to engage said outer surface with said central lobe to provide a first rocker assembly mode having a first valve lift capability, and for unlatching said slider member from said body; and
- d) means for extending said passage beyond said upper surface of said body to lengthen at least a portion of said second sliding surface of said passage to decrease a counter-torque moment between said slider member and said follower body.

2. A rocker arm assembly in accordance with claim 1 further comprising means in said slider member for receiving said means for extending during sliding of said slider in said passage.

3. A rocker arm assembly in accordance with claim 1 wherein said means for extending includes at least one stud having at least one surface formed as an extension of said second sliding surface of said passage.

4. A multiple-cylinder internal combustion engine having a camshaft having a central lobe and at least one lateral lobe, the engine comprising:

a two-step finger follower rocker arm assembly for variably activating a gas valve, including

a follower body having means for engaging said engine at a first end of said body and having means for engaging a valve stem of said gas valve at a second end of said body and having a passage formed in said body between said first end and said second end and

having an upper surface at the terminus of said passage adjacent said camshaft,

a slider member slidably disposed in said passage and having an outer surface for engaging said central lobe of said camshaft, and having a latching surface, and having a first sliding surface for engaging a second sliding surface of said passage, latching means disposed in said follower body for latching said slider member to said body to engage said outer surface with said central lobe to provide a first rocker assembly mode having a first valve lift capability, and for unlatching said slider member from said body, and

means for extending said passage beyond said upper surface of said body to lengthen at least a portion of said second sliding surface of said passage to decrease a counter-torque moment between said slider member and said follower body.

* * * * *