



INTERNATIONAL APPLICATION PUBLISHED UNDER THE PATENT COOPERATION TREATY (PCT)

<p>(51) International Patent Classification ⁶ : H04M 11/00, 1/64, 1/05, H04B 1/38, H04Q 7/00, H04R 25/00</p>	<p>A1</p>	<p>(11) International Publication Number: WO 99/03254 (43) International Publication Date: 21 January 1999 (21.01.99)</p>
<p>(21) International Application Number: PCT/US98/13588 (22) International Filing Date: 7 July 1998 (07.07.98) (30) Priority Data: 08/890,930 10 July 1997 (10.07.97) US (63) Related by Continuation (CON) or Continuation-in-Part (CIP) to Earlier Application US 08/890,930 (CON) Filed on 10 July 1997 (10.07.97) (71) Applicant (for all designated States except US): RESOUND CORPORATION [US/US]; 220 Saginaw Drive, Seaport Centre, Redwood City, CA 94065 (US). (72) Inventor; and (75) Inventor/Applicant (for US only): PUTHUFF, Steven, H. [US/US]; 13001 Saratoga Sunnyvale Road, Saratoga, CA 95070 (US). (74) Agent: KREBS, Robert, E.; Burns, Doane, Swecker & Mathis, L.L.P., P.O. Box 1404, Alexandria, VA 22313-1404 (US).</p>	<p>(81) Designated States: AL, AM, AT, AU, AZ, BA, BB, BG, BR, BY, CA, CH, CN, CU, CZ, DE, DK, EE, ES, FI, GB, GE, GH, GM, GW, HR, HU, ID, IL, IS, JP, KE, KG, KP, KR, KZ, LC, LK, LR, LS, LT, LU, LV, MD, MG, MK, MN, MW, MX, NO, NZ, PL, PT, RO, RU, SD, SE, SG, SI, SK, SL, TJ, TM, TR, TT, UA, UG, US, UZ, VN, YU, ZW, ARIPO patent (GH, GM, KE, LS, MW, SD, SZ, UG, ZW), Eurasian patent (AM, AZ, BY, KG, KZ, MD, RU, TJ, TM), European patent (AT, BE, CH, CY, DE, DK, ES, FI, FR, GB, GR, IE, IT, LU, MC, NL, PT, SE), OAPI patent (BF, BJ, CF, CG, CI, CM, GA, GN, ML, MR, NE, SN, TD, TG).</p> <p>Published <i>With international search report. Before the expiration of the time limit for amending the claims and to be republished in the event of the receipt of amendments.</i></p>	

(54) Title: PERSONAL COMMUNICATION DEVICE

(57) Abstract

A communication system provides two-way wireless communication between a user and at least one remote device. The communication system comprises at least one earpiece (400) worn by the user and a personal communication device (100) for receiving and transmitting signals over a wireless link to and from the earpiece. The personal communication device (100) includes voice recognition circuitry (140) which recognizes and interprets voice commands of the user. The personal communication device is configured to determine a remote device to receive each of the voice commands, and transmits the appropriate voice commands to the remote device, accordingly.

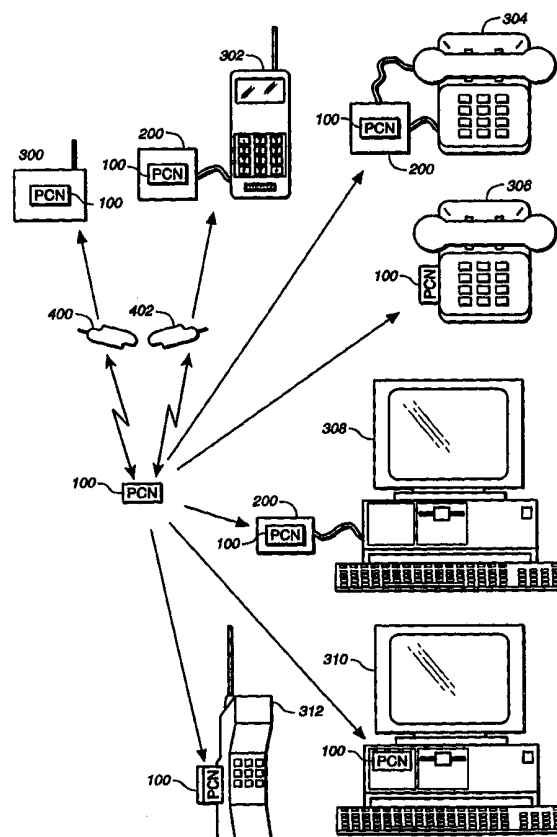

FOR THE PURPOSES OF INFORMATION ONLY

Codes used to identify States party to the PCT on the front pages of pamphlets publishing international applications under the PCT.

AL	Albania	ES	Spain	LS	Lesotho	SI	Slovenia
AM	Armenia	FI	Finland	LT	Lithuania	SK	Slovakia
AT	Austria	FR	France	LU	Luxembourg	SN	Senegal
AU	Australia	GA	Gabon	LV	Latvia	SZ	Swaziland
AZ	Azerbaijan	GB	United Kingdom	MC	Monaco	TD	Chad
BA	Bosnia and Herzegovina	GE	Georgia	MD	Republic of Moldova	TG	Togo
BB	Barbados	GH	Ghana	MG	Madagascar	TJ	Tajikistan
BE	Belgium	GN	Guinea	MK	The former Yugoslav Republic of Macedonia	TM	Turkmenistan
BF	Burkina Faso	GR	Greece	ML	Mali	TR	Turkey
BG	Bulgaria	HU	Hungary	MN	Mongolia	TT	Trinidad and Tobago
BJ	Benin	IE	Ireland	MR	Mauritania	UA	Ukraine
BR	Brazil	IL	Israel	MX	Mexico	UG	Uganda
BY	Belarus	IS	Iceland	MW	Malawi	US	United States of America
CA	Canada	IT	Italy	NE	Niger	UZ	Uzbekistan
CF	Central African Republic	JP	Japan	NL	Netherlands	VN	Viet Nam
CG	Congo	KE	Kenya	NO	Norway	YU	Yugoslavia
CH	Switzerland	KG	Kyrgyzstan	NZ	New Zealand	ZW	Zimbabwe
CI	Côte d'Ivoire	KP	Democratic People's Republic of Korea	PL	Poland		
CM	Cameroon	KR	Republic of Korea	PT	Portugal		
CN	China	KZ	Kazakistan	RO	Romania		
CU	Cuba	LC	Saint Lucia	RU	Russian Federation		
CZ	Czech Republic	LI	Liechtenstein	SD	Sudan		
DE	Germany	LK	Sri Lanka	SE	Sweden		
DK	Denmark	LR	Liberia	SG	Singapore		
EE	Estonia						

PERSONAL COMMUNICATION DEVICE

BACKGROUND OF THE INVENTION

1. Field of the Invention

The present invention is directed to a communication system for two-way
5 wireless communication. More particularly, the present invention is directed to a
communication system including a personal communication device which is
universally adaptable to at least one remote device for two-way wireless
communication between a user and the remote device.

2. State of the Art

10 Two-way wireless communication systems are well known. For example,
one known two-way wireless communication system is described in copending U.S.
Patent Application No. 08/479,629, filed on June 7, 1995 in the name of Jim
Anderson, and entitled "Hearing Aid With Wireless Remote Processor", the contents
of which are herein incorporated by reference in their entirety. In this system, audio
15 signals are picked up by a microphone in an earpiece worn by a user, transmitted
over a wireless link to a remote processor in which they can be processed to enhance
the signal quality and then: (1) returned to the earpiece for output to the wearer; or
(2) processed for transmission to a secondary unit (e.g., a cellular phone network).
In a similar manner, signals from the secondary unit can be received by the remote
20 processor, processed, and then transmitted to the earpiece.

A problem with this known system is that it is not universally adaptable to
any type of secondary unit. Connecting a particular secondary unit to the remote
processor requires special adaptation circuitry. This makes it prohibitively
expensive and complex to connect the remote processor to many different types of
25 secondary units.

Thus, there is a need for a communication system which permits two-way
wireless communication between a user and at least one remote device which is
universally adaptable to a variety of remote devices, and which can be connected to a
single remote device or to a plurality of different remote devices at the same time or
30 at different times in a simple manner.

SUMMARY OF THE INVENTION

The present invention is directed to a two-way wireless communication system between a user and at least one remote device which is universally adaptable to a variety of remote devices. Further, the present invention is directed to a two-
5 way wireless communication system between a user and a plurality of remote devices which can be connected to the plurality of remote devices at the same time or at different times in a simple manner. In addition, the present invention is directed to a two-way wireless communication system between a user and at least one remote
10 device which enables the user to control the remote device and/or to communicate with a third party via the remote device.

According to exemplary embodiments of the present invention, the foregoing objects, as well as other objects are met by a communication system comprising at least one earpiece worn by a user and a personal communication device for receiving and transmitting signals over a wireless link to and from the earpiece. The personal
15 communication device includes voice recognition means which recognizes and interprets voice commands of the user. The personal communication device is configured to determine a remote device which is to receive each of the voice commands. The voice commands are used to control the remote device, and the user can communicate with a third party via the remote device.

20 According to one embodiment of the present invention, the personal communication device is connected to one remote device at a time, either directly or via an adaptor. The adaptor universally connects the personal communication device to a variety of remote devices. The personal communication device is configured to determine voice commands that are to be sent to the remote device and sends these
25 commands to the remote device, accordingly.

According to a second embodiment of the present invention, the personal communication device is connected to a plurality of remote devices at the same time or at different times, via, for example, a universal adaptor. The personal communication device is configured to determine which remote device the voice

commands are to be sent to, and sends the commands to the appropriate remote device, accordingly.

BRIEF DESCRIPTION OF THE DRAWINGS

The objects and advantages of the present invention will be understood by
5 reading the following detailed description in conjunction with the drawings, wherein like elements are identified by like reference numbers, and wherein:

Figure 1 illustrates a communication system according to a first embodiment of the present invention;

Figure 2 illustrates a communication system according to a second
10 embodiment of the present invention;

Figure 3 illustrates in detail an exemplary universal adapter which can be implemented in the communication system shown in Figures 1 and 2;

Figure 4 illustrates a personal communication device which can be implemented in the communication system shown in Figures 1 and 2;

15 Figure 5 illustrates in detail an exemplary Kernel Operating System which can be implemented in the personal communication device shown in Figure 4; and

Figure 6 illustrates in detail an exemplary Data I/O Manager Buffer which can be implemented in the personal communication device shown in Figure 4.

DETAILED DESCRIPTION OF THE PREFERRED EMBODIMENTS

20 Figure 1 illustrates a communication system according to one embodiment of the present invention. Referring to Figure 1, a personal communication device, referred to as a personal communication node (PCN) 100, is connected via wireless links to earpieces 400 and 402 worn by a user. The wireless links can, for example, be radio frequency links such as that described in the above-referenced U.S. Patent
25 Application No. 08/479,629. Further, the earpieces 400 and 402 can, for example, be configured as described in the aforementioned copending U.S. Patent Application. Although two earpieces are shown and can be worn by the user, one

skilled in the art will appreciate that it may be desirable for the user to wear only one earpiece.

The PCN 100 permits a user to control at least one remote device and communicate wirelessly with a third party via the remote device simply by issuing
5 voice commands. The PCN 100 recognizes and interprets the voice commands of the user, determines whether the commands are to be sent to a given remote device to which it is connected, and forwards the voice commands to the appropriate remote device, accordingly. As shown by the arrows in Figure 1, the PCN 100 can be coupled to several different types of remote devices, either directly or through a
10 universal adapter 200.

For example, the PCN 100 can be connected directly to a cellular telephone 300 that is adapted for connection to the PCN. As shown in Figure 1, the cellular telephone 300 has no keyboard or LED display and is instead controlled solely by voice commands from the user as described in more detail below. Alternately, the
15 PCN 100 can be connected to a cellular telephone or pager 302 via an adapter 200. Figure 1 also shows the PCN 100 connected directly to a cellular phone 312 that is adapted for connection to the PCN 100. The cellular phone 312 can be used in a normal manner by entering commands via a keyboard or in response to voice commands forwarded by the PCN 100. Using the PCN 100 connected to the cellular
20 telephones 300, 302, and/or 312 the user can answer calls, initiate calls, receive or send messages, and so on, simply by issuing voice commands.

The PCN 100 can also be connected via the adapter 200 to a fixed wireline telephone 304. The adapter 200 is connected between the handset of the telephone 304 and the telephone body. Alternately, the PCN 100 can be connected directly to
25 a fixed wireline telephone 306 that is adapted to be connected to the PCN. With the PCN 100 connected to the fixed wireline telephones 304 or 306, the user controls the TIP and RING functions of the telephone to dial a number to initiate a call or to answer a call, respectively, simply by issuing voice commands.

The PCN 100 can also be connected to a personal computer 308 via the
30 adapter 200 through a parallel or serial port on the personal computer 308.

Alternately, the PCN 100 can be connected directly to a personal computer 310 that includes I/O jacks for connection to the PCN. With the PCN 100 connected either directly or via the adapter 200, the user can use the personal computers 308 and 310 for Internet applications, to update schedules, to input data, to control calls, to
5 dictate information, for intelligent applications, and so on, simply by issuing voice commands.

Figure 2 illustrates a communication system according to a second embodiment of the present invention. As in Figure 1, the PCN 100 is connected via wireless links to earpieces 400 and 402 worn by a user. In Figure 2, however, the
10 PCN 100 is connected to a plurality of different remote devices at the same time or at different times through a universal adapter 200. For example, as shown in Figure 2, the PCN 100 can be connected to a cellular telephone 302, a fixed wireline telephone 304, and a personal computer 308 at the same time or at different times via the universal adapter 200. The connection of the adapter 200 to these remote
15 devices is the same as that described above with reference to Figure 1. The PCN 100 shown in Figure 2 is configured to determine which of the remote devices a voice command is to be sent to and forwards the voice command to the appropriate device, accordingly. This is described in more detail below.

Although Figures 1 and 2 show the PCN 100 connected to remote devices
20 directly or through an adapter 200, the PCN 100 can also be connected to the remote devices directly or through an adapter 200 via another device such as a LAN, a bidirectional FM device, or an infrared device. Such devices extend the distance through which the PCN 100 can communicate with or control remote devices. In addition, although the PCN 100 and the adapter 200 are shown in Figures 1 and 2 as
25 separate devices, they can be incorporated into a single device.

Figure 3 illustrates in detail an exemplary universal adapter which can be implemented in the communication system shown in Figures 1 and 2. The universal adapter 200 is connected to the PCN 100 via a connector 280. The connector 280 includes ports P1-P7 connected to respective ports PCN1-PCN7 of the PCN 100.
30 For example, port P1 is connected to a positive voltage port PCN1, port P2 is

connected to a ground port PCN2, port P3 is connected to a voice out port PCN3, port P4 is connected to a voice in port PCN4, port P5 is connected to a data I/O port PCN5, port P6 is connected to a control port PCN6, and port P7 is connected to a clock port PCN7. Remote devices configured for connection directly to the PCN
5 100 are connected through the ports PCN1-PCN7 of the PCN 100.

The universal adapter 200 also includes various ports for connection to remote devices. For example, the universal adapter 200 includes ports 220 and 230 for connection to a telephone handset IN and OUT. These ports can include, for example, standard RJ-11 connectors. The universal adapter 200 also includes a
10 Serial Adapter port 240 for connection to a serial port of a CPU, and ports 250 and 252 for connection to cellular telephone control and a cellular telephone audio I/O jack, respectively.

The universal adapter 200 includes an I/O Control Unit 210 for controlling the flow of data and control signals through the adapter between the PCN 100 and
15 the remote devices in response to, for example, voice commands received via connector 280. Control and clock signals for the CPU received via PCN ports P6 and P7 are transferred under the control of the I/O Control Unit 210 directly to the CPU via the Serial Adapter port 240. Control and clock signals for the telephone handset are transmitted from the I/O Control Unit 210 to the TIP/RING Unit 260
20 which controls the TIP/RING functions of the telephone handset in response to, for example, voice commands received via connector 280. Control and clock signals for the cellular telephone are also transmitted from the I/O Control Unit 210 to the cellular telephone via the port 250.

The universal adapter 200 receives and transmits digital data from and to the
25 PCN 100 via the ports PCN5 and P5. Digital data is transmitted to and received from the CPU via the I/O control unit 210 and the Serial Adapter port 240.

The universal adapter 200 receives digital voice information from the PCN
100 via the ports PCN3 and P3 and transmits digital voice information from a remote device to the PCN 100 via the ports P4 and PCN4. Voice data received at
30 port P3 is processed in a voice output circuitry 292 (e.g., an analog operational

amplifier with adjustable feedback resistance) and transmitted to the cellular phone via the audio I/O jack 252, to the telephone handset via the port 230, and/or to the CPU via the Serial Adapter port 240. Voice data received from the cellular phone via audio I/O jack 252, from the telephone handset via the port 220, and from the
5 CPU via the Serial Adapter port 240 is processed by the voice input circuitry 290 (i.e., similar to the voice output circuitry), and delivered to the PCN 100.

According to an exemplary embodiment, the universal adapter 200 need not include an internal power supply, but rather can be connected to an external AC power supply 410 via an AC/DC Adapter 400. The universal adapter 200 includes a
10 voltage regulator 270 and a decoupling capacitor 272 for this purpose. The voltage regulator 270 regulates voltage supplied to the PCN 100 via the ports P1 and PCN1. In the case of a PCN 100 connected directly to a remote device, the voltage regulator 270 and decoupling capacitor 272 can be included in the PCN 100, as shown in Figure 4 below.

15 Figure 4 illustrates a personal communication node according to an exemplary embodiment of the present invention. For illustrative purposes, the PCN 100 is depicted in Figure 4 as connected to a single remote device, the cellular telephone 312, adapted for connection directly to the PCN 100.

Referring to Figure 4, the PCN 100 processes signals received via the
20 earpiece(s) worn by the user, including voice commands to control the cellular telephone 312 as well as voice data to be conducted over the cellular telephone network, and transmits appropriate signals to the cellular telephone 312. The PCN 100 also processes signals from the telephone 312 and transmits these signals to the earpiece(s). To perform these functions, the PCN 100 includes a Kernel Operating
25 System 110, an Audio Digital Signal Processing (DSP) Algorithms Unit 120, a Data Input/Output (I/O) Manager (Mgr) Buffer 130, a Voice Recognition Command Manager 140, a Sound Processing System 150, Data I/O Buffers 160 and 162, an Adaptive Speech Filtering and Noise Cancellation Unit 180, and a Memory Unit 190. The Kernel Operating System 110 includes software for scheduling software
30 tasks, handling interrupt requests, scheduling data input/output, and allocating

memory for various applications in the PCN 100. Figure 5 illustrates in detail an exemplary Kernel Operating System which can be implemented in the personal communication device shown in Figure 4. A Status and Control Manager (Mgr) 115 of the Kernel Operating System 110 handles status (clock) and control information received from and transmitted to the Data I/O Mgr Buffer 130. Scheduling of data input/output from various elements in the PCN 100 is handled by the Figure 5 I/O Data Handler 114 under the control of the Status and Control Mgr 115. The Memory Management Handler 113 allocates memory from the Memory Unit 190 for various tasks in the PCN 100 under the control the Status and Control Mgr 115.

10 Memory is allocated and data I/O is scheduled according to software task and interrupt requests.

Software task requests from various elements in the PCN 100, such as the Figure 4 Audio DSP Algorithms Unit 120, are handled by the Figure 5 Software Task Handler 112. The Software Task Handler 112 issues software task instructions under the control of the Status and Control Mgr 115.

15

Interrupt requests from various elements in the PCN 100, such as the Figure 4 Data I/O Mgr Buffer 130 and the Audio DSP Algorithms Unit 120, are handled by the Figure 5 Interrupt Handler 111, which issues interrupt instructions under the control of the Status and Control Mgr 115. The Interrupt Handler 111 includes a prioritized list of applications, which indicates which applications can interrupt other applications. As those skilled in the art will appreciate, this list can be selectively prioritized in any manner desired by the user. For example, the Interrupt Handler 111 can assign higher priority to incoming data from a CPU than to processing of an ongoing telephone call (or vice versa). Thus, when the Interrupt Handler 111 receives a request to interrupt from the Figure 4 Data I/O Mgr Buffer 130 based on receipt of data from the CPU, the Interrupt Handler responds by interrupting operation of the Sound Processor 150. The Interrupt Handler 111 bases interrupt instructions on idle time reports from the Idle Time Unit 116, and does not issue interrupt instructions if the reports indicate that the PCN 100 is idle. The Idle Time

20

25

Unit 116 bases the idle time reports on information from the I/O Data Handler 114 which indicates the schedule of data I/O at a given time.

Referring again to Figure 4, the Sound Processing Unit 150 includes basic software used, for example, in a hearing aid to enhance signal quality. The Sound
5 Processing Unit 150 can be implemented with a remote processor such as that described in the above-referenced copending U.S. Patent Application No. 08/479,629. The Voice Recognition Command Manager 140 includes software which interprets voice commands from the user. For example, a voice command can be interpreted as a command to direct the cellular telephone 312 of Figure 4 to
10 perform a certain function. The Voice Recognition Command Manager 140 can be implemented with any conventional voice recognition software, such as Motorola's Lexicus Microbrain or the Voice Dialer, Model VCS 2060 of Voice Control Systems Inc. in Dallas, Texas. The Voice Recognition Command Manager 140 is "trained" ahead of time during a set up phase to recognize the voice of a specific user. For
15 example, the user simply speaks a series of selected words, and the Voice Recognition Command Manager 140 becomes programmed (i.e., trained) in known fashion to recognize any word spoken by the user based on these selected words. The Voice Recognition Command Manager 140 can, for example, be language-independent. That is, it can be trained to recognize a user's voice in any language.
20 Once the Voice Recognition Command Manager 140 is trained to the voice of the user, it need not be trained again.

The Voice Command Manager 140 matches a voice command to a particular control function in a library or look-up table of memory 190. The voice command is also matched, via the look-up table, to a particular remote device. After matching
25 the voice command to a particular control function and a particular remote device, the Voice Recognition Command Manager 140 then issues an appropriate control code to, for example, control gating of commands and/or data to one or more remote devices via the Figure 4 Kernel Operating System and, where the adapter 200 is used, the Figure 3 I/O control 210. If the voice command does not match a control
30 function in the library or look-up table, no control code is issued. Also, if the voice

command corresponds to a remote device to which the PCN 100 is not connected, no control code is issued.

The Audio DSP Algorithms Unit 120 provides digital sound processing algorithms for the Voice Recognition Command Mgr 140 and the Sound Processing Unit 150 under the control of the Kernel Operating System 110. The Audio DSP Algorithms Unit 120 can be implemented in accordance with features described in U.S. Patent No. 5,479,522 (Lindemann et al.), the contents of which are hereby incorporated by reference in their entirety.

The Data I/O Mgr Buffer 130 temporarily stores data, voice, and control signals. Figure 6 illustrates in detail an exemplary Data I/O Manager Buffer which can be implemented in the personal communication node shown in Figure 4. The Data I/O Mgr Buffer 130 includes input and output buffers 131 and 132 for outputting and receiving, respectively, digital data, digital voice information, and clock and control signals to and from the Kernel Operating System 110. Digital data from the Output Buffer 132 is converted into serial form in a Parallel to Serial Converter 134 and delivered to the remote device via the port PCN5. Digital data from the remote device is converted into parallel form in the Serial to Parallel converter 137 and delivered to the Kernel Operating System 110 via the Input Buffer 131. The digital voice data is transmitted across, for example, 8 to 16 bit buses. Digital voice data is delivered from the Output Buffer 132 to an 8 to 16 bit register 135, converted into analog form in the D/A converter 192, and transmitted to the remote device. Digital voice data received from the remote device is converted into digital form in the A/D converter 194, stored in the 8 to 16 bit register 136, and delivered to the Input Buffer 131 for output to the Kernel Operating System 110. The Data I/O Mgr Buffer 130 also includes a Status Buffer 133 for storing clock and control information transferred between the Kernel Operating System 110 and the remote device.

Referring again to Figure 4, the personal communication device also includes an Adaptive Speech Filtering and Noise Cancellation Unit 180 which enhances signal quality by filtering and cancelling noise in the signal. The Adaptive Speech Filtering

and Noise Cancellation Unit 180 can be implemented in accordance with, for example, U.S. Patent No. 5,140,640 (Graupe et al.) and/or U.S. Patent No. 5,452,361 (Jones) entitled "Reduced VLF Overload Susceptibility Active Noise Cancellation Headset" assigned to Noise Cancellation Technology (NCT), the contents of which are hereby incorporated by reference in their entirety.

In the exemplary embodiment illustrated, the PCN 100 need not include a power supply, but rather can be connected to an external AC power supply 410 via a voltage regulator and decoupling unit 164. Although shown as a separate element, the AC power supply 410 can, for example, be the same power supply used to power the cellular telephone 312. The voltage regulator and decoupling unit 164 can include the voltage regulator 270 and the decoupling capacitor 272 shown in Figure 3. Power is supplied from the external power supply and regulated by the voltage regulator and decoupling unit 164 in the same manner described above with reference to Figure 3.

In an exemplary embodiment, the PCN 100 communicates wirelessly with the earpiece(s), although wired communication can of course be used. In the Figure 4 embodiment, the PCN 100 receives signals from the earpieces via the Receiver 170 and stores the signals in a Data I/O Buffer 160, and the PCN 100 transmits signals to the earpiece(s) after being stored in the Data I/O buffer 162 via the Transmitter 172. Signals are converted into analog form and forwarded to the cellular telephone 312 via the D/A converter 192. Signals are received from the cellular telephone 312 and converted into digital form in the A/D Converter 194. The Data I/O Buffers 160 and 162, the Receiver 170, the Transmitter 172, and the converters 192 and 194 can be implemented with any suitable conventional devices.

According to an exemplary embodiment, the PCN device 100 operates in the following manner. When the cellular telephone 312 rings to indicate an incoming call, the ring signal can be transmitted directly to the user, for example via the microphone in the earpiece(s), or transmitted to the user via the PCN 100 and the earpiece(s). If the ring signal is an audible signal, the user can, of course, respond to it by commanding that the telephone be picked up. However, if the user has a

hearing impairment, the audible ring signal can be transmitted via the earpiece
microphone and speaker. That is, the audible ring of the telephone can be detected
by the earpiece(s) and passed to the user (e.g., a hearing impaired user) after signal
enhancement is performed by the PCN 100. Alternately, if the ring signal is a non-
5 audible signal, it can be transmitted by the PCN 100 to the earpiece. In such a case,
the analog ring signal is converted into digital form in the A/D converter 194 and
forwarded to the Data I/O Manager Buffer 130 which temporarily stores the ring
signal.

The Data I/O Mgr Buffer 130 forwards the ring signal to the Audio DSP
10 Algorithms Unit 120 and the Sound Processing Unit 150 via the Kernel Operating
System 110. The Sound Processing Unit 150 processes the ring signal to enhance its
signal quality according to the Audio DSP Algorithms Unit 120 under the control of
the Kernel Operating System 110.

The processed ring signal is forwarded from the Sound Processing Unit 150
15 to the Data I/O Buffer 162 via the Kernel Operating System 110. The Data I/O
Buffer 162 delivers the processed ring signal to the Transmitter 172 which transmits
the ring signal to the earpiece(s) worn by the user.

When the user hears the ring signal, either directly or through the
earpiece(s), he or she simply commands the telephone 312 to go off-hook by issuing
20 a voice command, such as "Pick-up cellular phone". This voice command is picked
up by microphone(s) in the earpiece(s) and transmitted across the wireless link(s) to
the Receiver 170. The Receiver 170 forwards the voice command in digital form to
the Kernel Operating System 110 via the Data I/O Buffer 160. The voice command
is also forwarded to the Adaptive Speech Filtering and Noise Cancellation Unit 180
25 which filters and cancels noise in the voice command and then forwards the voice
command to the Voice Recognition Command Manager 140.

The Voice Recognition Command Manager 140 matches the voice command
to a particular control code and a particular remote device and forwards the control
code to the Kernel Operating System 110 via the Audio DSP Algorithms Unit 120.
30 The Kernel Operating System 110 forwards the control code to the Data I/O Mgr

Buffer 130 which, in turn, forwards the control code to the cellular telephone 312 via the port PCN6. For a plurality of remote devices connected to the PCN 100, the control code is forwarded to the appropriate remote device from the Data I/O Mgr Buffer 130 and, where the Figure 3 adapter 200 is used, via the I/O control 210.

- 5 The cellular telephone 312 recognizes the control code as a command to go off-hook and responds accordingly. In this manner, the voice command issued by the user causes the cellular telephone 312 to go off-hook.

The user can then begin a typical conversation on the telephone network by speaking normally. The user's voice is picked up by the microphone(s) in the
10 earpiece(s), transmitted over the radio link to the Receiver 170, and processed by the PCN 100 in the same manner as described above for the voice command, except that the voice information is processed by the Sound Processing Unit 150 according to the Audio DSP Algorithms before being forwarded to the Kernel Operating System 110, and the voice information is delivered to the D/A converter 192 from the port
15 PCN3 for conversion into analog form before being delivered to the cellular telephone 312. Voice information and/or data from a third party caller is picked up by the cellular telephone 312, converted into digital form by the A/D converter 194, received at the port PCN4 and processed in the PCN 100, and transmitted wirelessly to the speaker(s) in the earpiece(s) via the Transmitter 172 in the same manner
20 described above for the ring signal.

When the user wants to terminate the call, he or she merely issues a voice command such as "Hang up". This voice command is transmitted to the PCN 100 and interpreted by the Voice Recognition Manager 140 as a command to terminate the call, and an appropriate control code is issued. The control code is forwarded to
25 the cellular telephone 312 in the manner described above for the call initiation voice command. In this manner, the voice command issued by the user causes the telephone 312 to go on-hook.

The operation described above for the cellular telephone 312 can also be used to issue commands to control and to communicate with other remote devices, such as
30 fixed wireline phones, personal computers, and so on, connected directly or through,

for example, the universal adaptor 200 to the PCN 100. For a remote device such as a computer, digital data is processed in a similar manner, except that it is forwarded from and delivered to the PCN via the port PCN5 without conversion to digital or analog form.

5 The remote devices described in the embodiments above are shown for illustrative purposes only. One skilled in the art will appreciate that the PCN 100 can be connected to other types of remote devices. For example, the PCN 100 can be connected to a tapedeck for hands-free control of the speed and radio/tapedeck functions in, for example, an automobile. The PCN 100 can also be used to control
10 other functions in an automobile, such as cruise control, temperature settings, or any other function conventionally controlled by hand. Similarly, the PCN 100 can be connected to control a stereo, a CD player, and a television or to program a VCR simply by stating the name, channel, and time of a program to be recorded verbally.

 The PCN 100 can also be connected to a remote device in an operating room
15 of a hospital. The remote device can be controlled by voice commands to monitor medical conditions such as heartbeat, blood pressure, temperature, and so on. Vital statistics of a patient can thus be monitored by known sensors, and used to supply information to the doctor on command. Alternately, the information can be delivered to a doctor wearing the earpiece(s), and then used to either automatically
20 initiate medical procedures, or to initiate such medical procedures in response to voice commands of the doctor (e.g., medical procedures such as administering more medicine). In a similar manner, the PCN 100 can also be connected to control exercise equipment in response to verbal commands of the user or to supply audible output to the user in response to PCN monitoring of heart attack conditions, high
25 blood pressure, high cholesterol, and other medical conditions detected by dedicated sensors worn by the user. Information gathered by the PCN from the various sensors can be provided directly to the individual or can be used to initiate automatic functions such as automatically dialing "911" in case of an emergency.

 The PCN 100 can also be used in combination with other PCN devices to
30 provide wireless communication between individuals, such as soldiers in the field.

From the examples provided above, it is apparent that the PCN can be used in many different applications to control remote devices and to communicate with third parties via the remote devices.

It will be appreciated by those of ordinary skill in the art that the present
5 invention can be embodied in other specific forms without departing from the spirit
or essential characteristics thereof. The presently disclosed embodiments are
therefore considered in all respects to be illustrative, and not restrictive. The scope
of the invention is indicated by the appended claims, rather than the foregoing
description, and all changes that come within the meaning and range of equivalence
10 thereof are intended to be embraced therein.

WHAT IS CLAIMED IS:

1. A communication system for providing two-way wireless communication between a user and at least one remote device, the communication
5 system comprising:
 - at least one earpiece worn by the user; and
 - a personal communication device for receiving and transmitting signals over a wireless link to and from said earpiece, wherein said personal communication device includes voice recognition means for recognizing and
10 interpreting voice commands of the user, said personal communication device being configured to determine a remote device which is to receive each of said voice commands and to transmit appropriate signals to the remote device in response to each of said voice commands.
2. The communication system of claim 1, wherein the personal
15 communication device is connected to a plurality of remote devices at the same time or at different times.
3. The communication system of claim 1, wherein the personal communication device is connected to a single remote device.
4. The communication system of claim 1, further comprising an adapter
20 for adapting the personal communication device to a plurality of different types of remote devices.
5. The communication system of claim 1, wherein the personal communication device transmits voice commands to the remote device to control functions of the remote device.

6. The communication system of claim 1, wherein the personal communication device transmits signals to the remote device which are transmitted by the remote device to a third party.

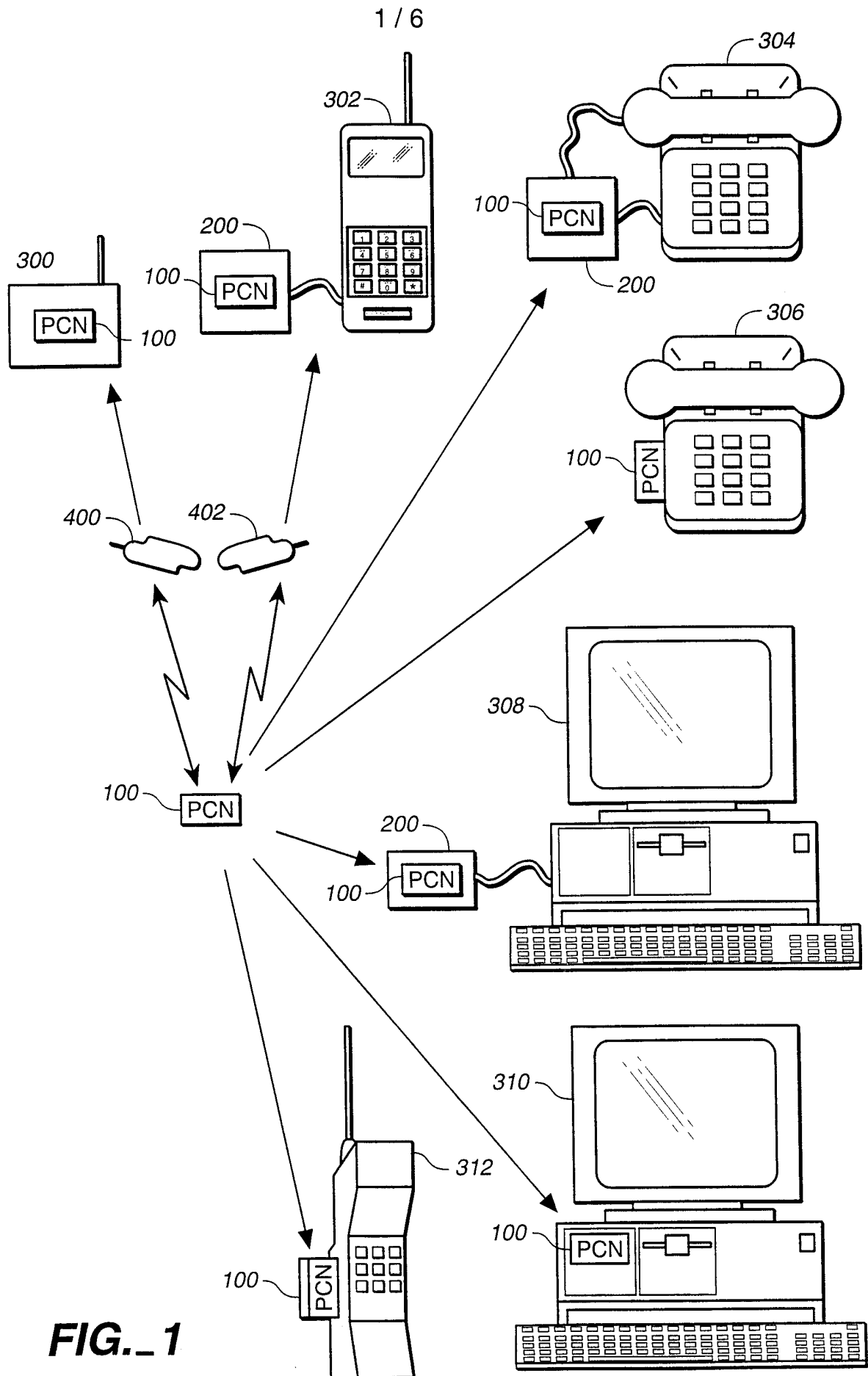

FIG. 1

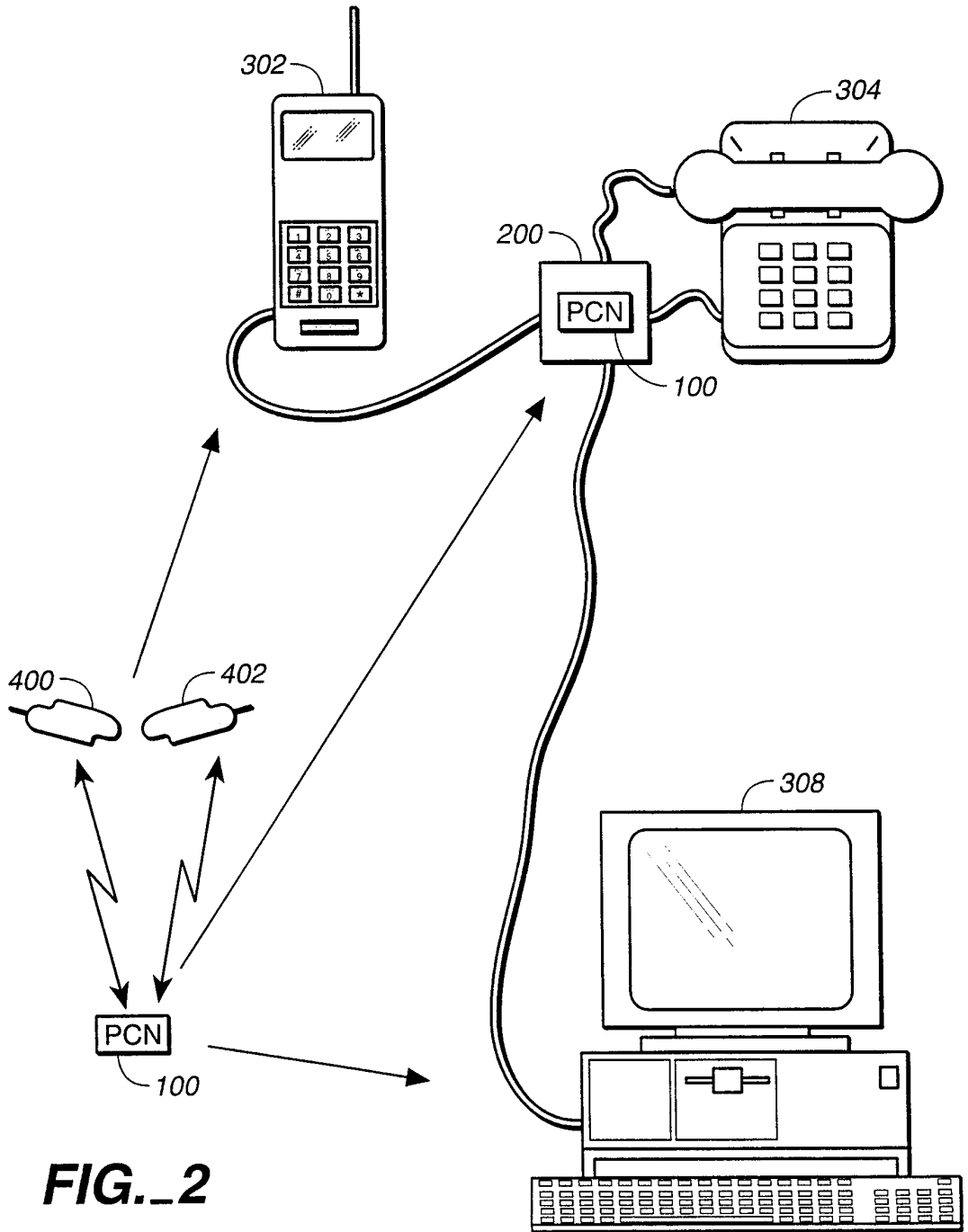

FIG. 2

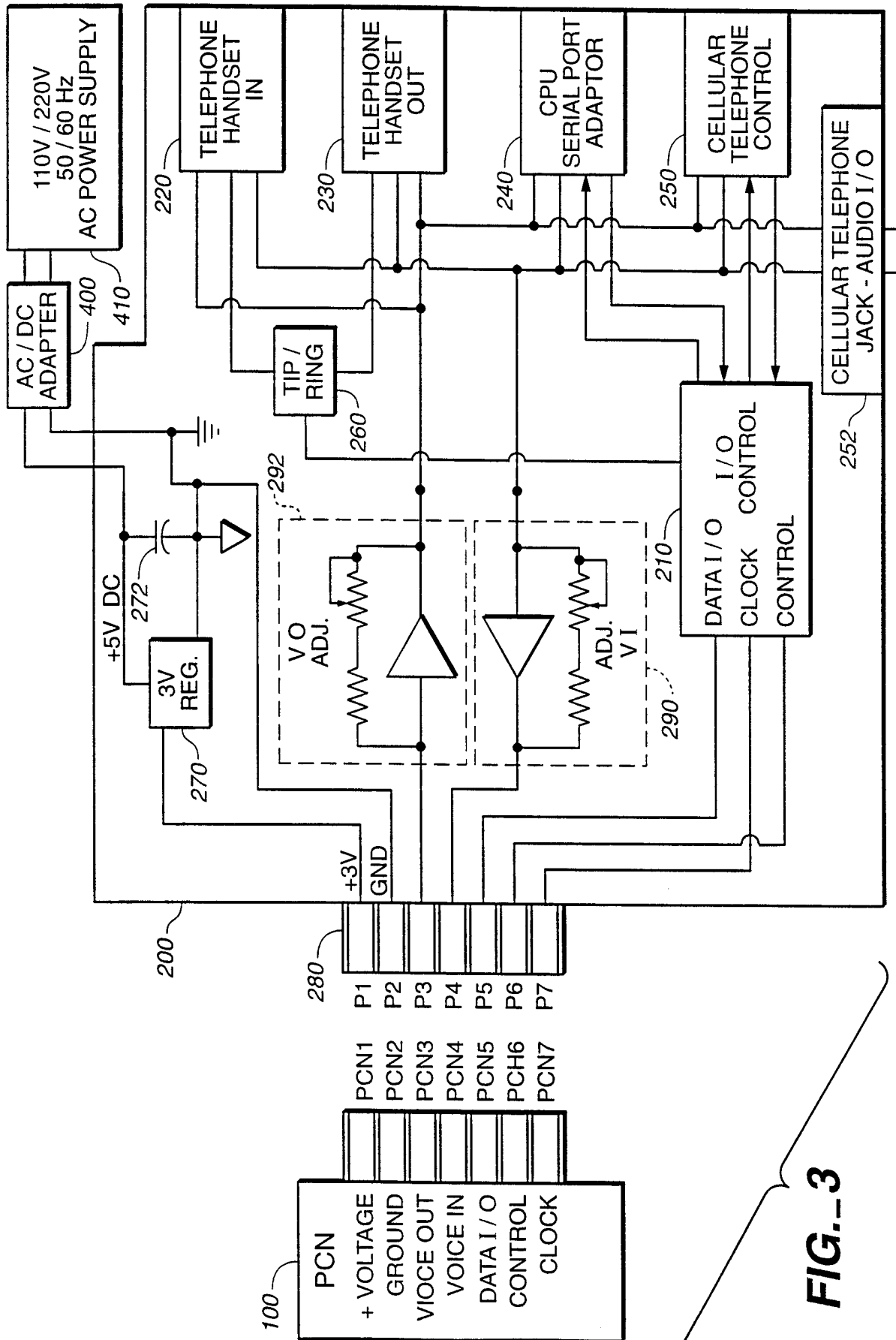

FIG. 3

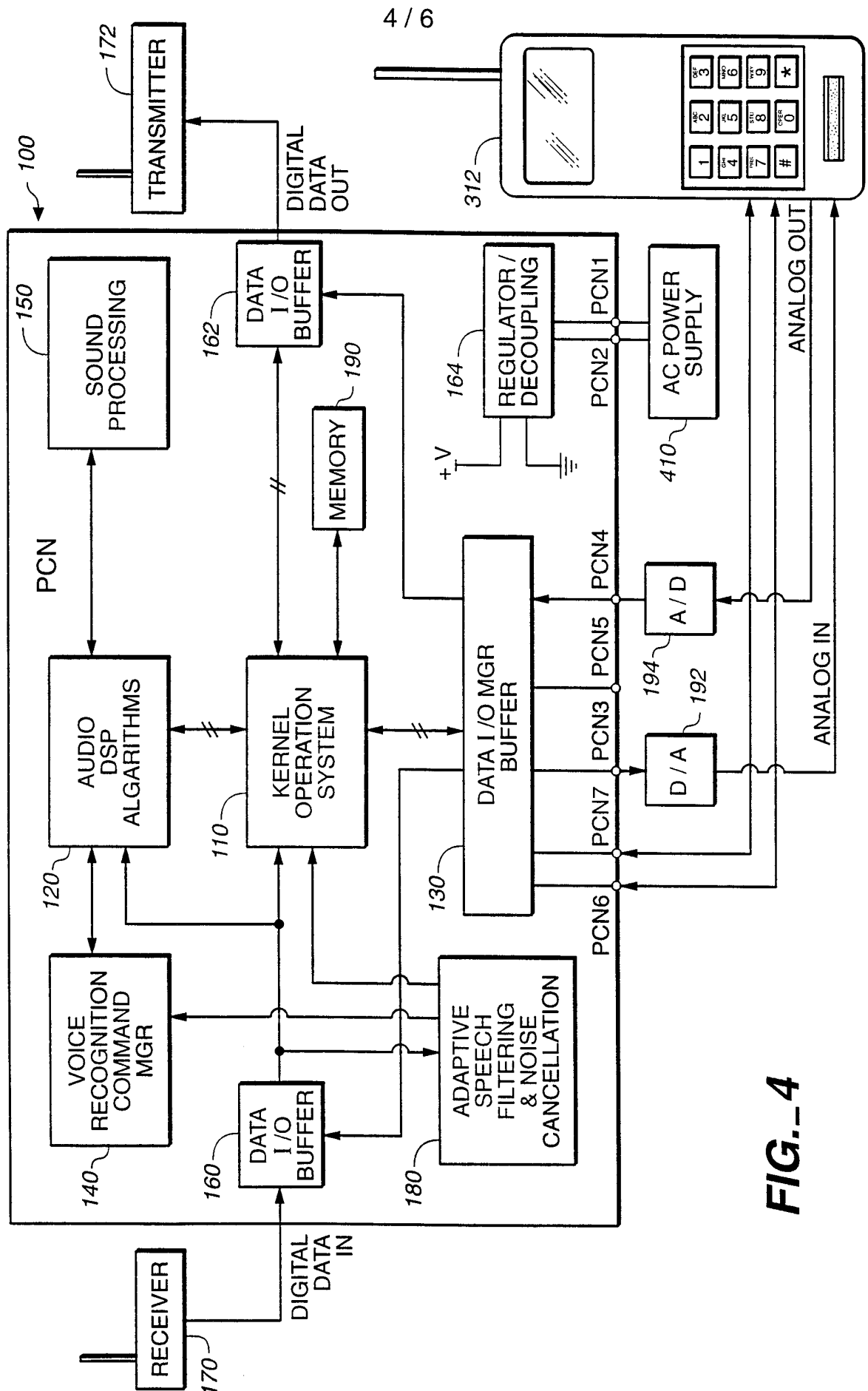

FIG. 4

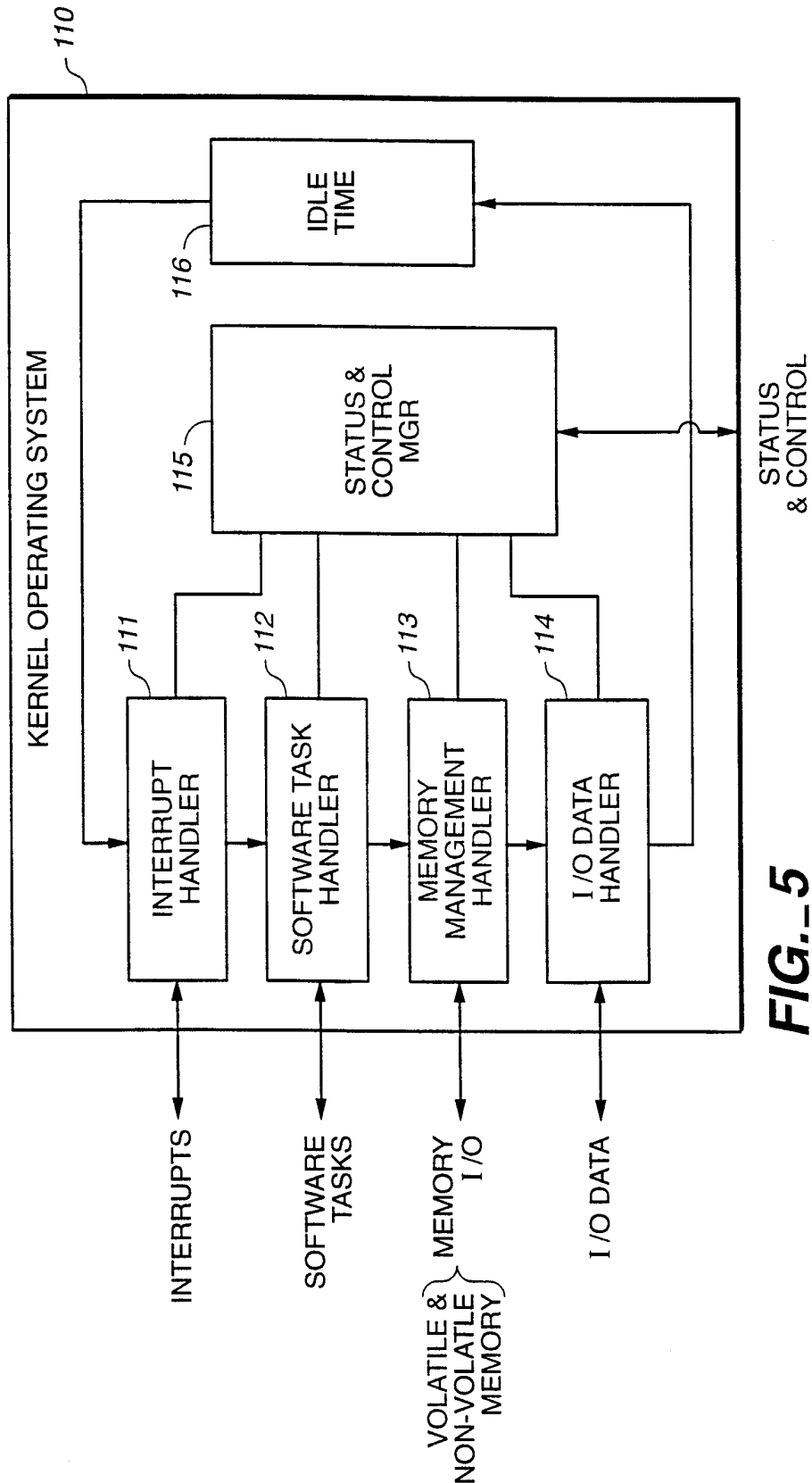

FIG. 5

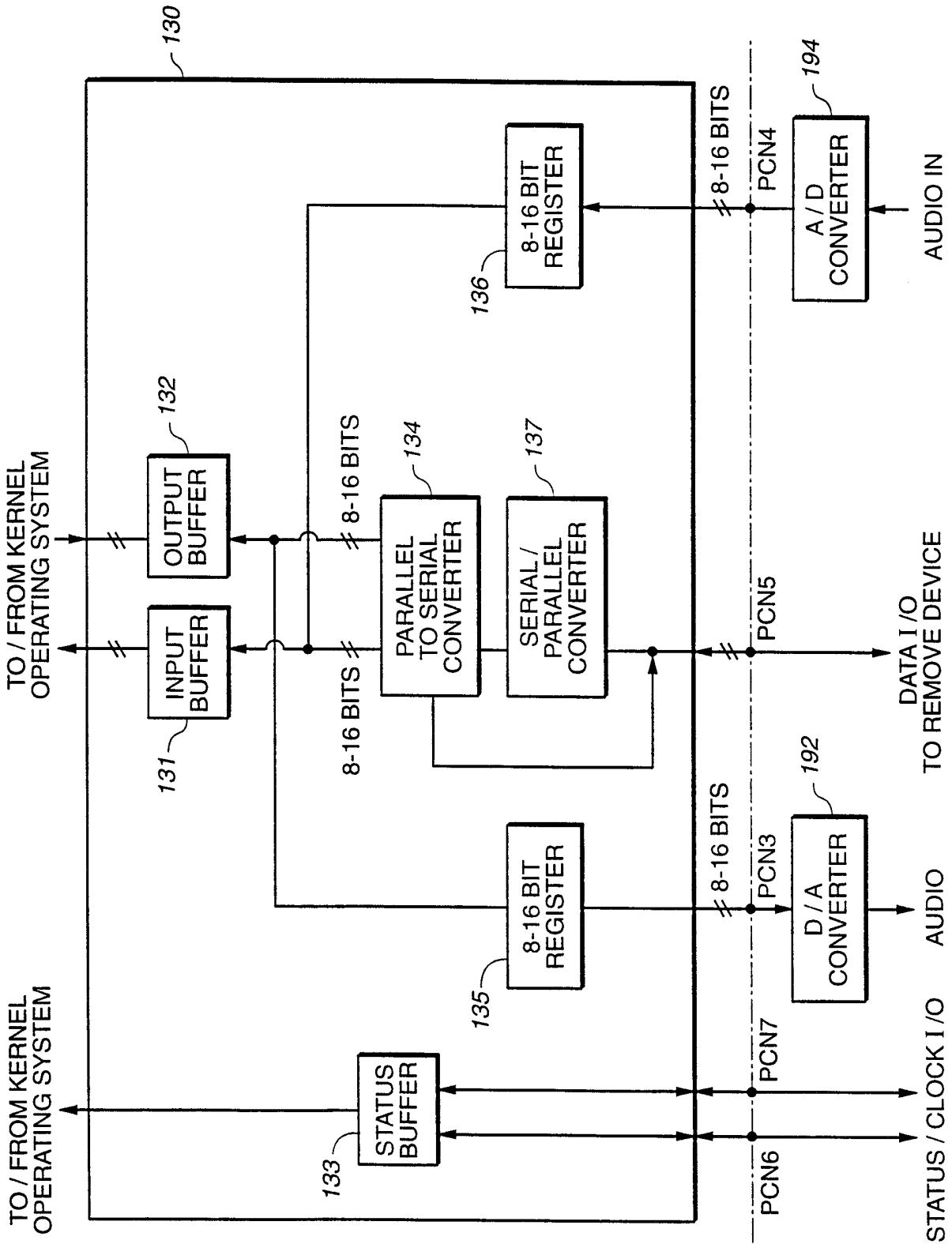

FIG. 6

INTERNATIONAL SEARCH REPORT

International application No.
PCT/US98/13588

A. CLASSIFICATION OF SUBJECT MATTER
 IPC(6) : H04M 11/00, 1/64, 1/05; H04B 1/38; H04Q 7/00; H04R 25/00
 US CL : Please See Extra Sheet.
 According to International Patent Classification (IPC) or to both national classification and IPC

B. FIELDS SEARCHED
 Minimum documentation searched (classification system followed by classification symbols)
 U.S. : Please See Extra Sheet.

Documentation searched other than minimum documentation to the extent that such documents are included in the fields searched

Electronic data base consulted during the international search (name of data base and, where practicable, search terms used)
 APS

C. DOCUMENTS CONSIDERED TO BE RELEVANT

Category*	Citation of document, with indication, where appropriate, of the relevant passages	Relevant to claim No.
X, P Y	US 5,721,783 A (ANDRSON) 24 FEBRUARY 1996, FIG. 1; COL. 25, LINE 15 TO COL. 26, LINE 19; COL. 27, LINE 45 TO COL. 28, LINE 68; COL. 5, LINE 61 TO COL. 6, LINE 25.	1-3, 5, 6 4
Y, P	US 5,742,905 A (PEPE ET AL.) 21 APRIL 1998 FIG. 3; COL. 3, LINES 10-43.	4

Further documents are listed in the continuation of Box C. See patent family annex.

- | | |
|---|--|
| * Special categories of cited documents: | *T* later document published after the international filing date or priority date and not in conflict with the application but cited to understand the principle or theory underlying the invention |
| *A* document defining the general state of the art which is not considered to be of particular relevance | *X* document of particular relevance; the claimed invention cannot be considered novel or cannot be considered to involve an inventive step when the document is taken alone |
| *E* earlier document published on or after the international filing date | *Y* document of particular relevance; the claimed invention cannot be considered to involve an inventive step when the document is combined with one or more other such documents, such combination being obvious to a person skilled in the art |
| *L* document which may throw doubts on priority claim(s) or which is cited to establish the publication date of another citation or other special reason (as specified) | *g* document member of the same patent family |
| *O* document referring to an oral disclosure, use, exhibition or other means | |
| *P* document published prior to the international filing date but later than the priority date claimed | |

Date of the actual completion of the international search 06 OCTOBER 1998	Date of mailing of the international search report 09 NOV 1998
--	---

Name and mailing address of the ISA/US Commissioner of Patents and Trademarks Box PCT Washington, D.C. 20231 Facsimile No. (703) 305-3230	Authorized officer JEAN A. GELIN  Telephone No. (703) 305-4847
---	---

INTERNATIONAL SEARCH REPORT

International application No.
PCT/US98/13588

A. CLASSIFICATION OF SUBJECT MATTER:

US CL :

455/90, 403, 550, 563, 568, 569, 575.

379/67.1, 88.01, 88.02.

381/312, 314, 315, 316.

B. FIELDS SEARCHED

Minimum documentation searched

Classification System: U.S.

455/90, 403, 550, 563, 568, 569, 575.

379/67.1, 88.01, 88.02.

381/312, 314, 315, 316.