

No. 831,726.

PATENTED SEPT. 25, 1906.

L. LONG.

DEVICE FOR ROLLING BANDAGES.

APPLICATION FILED SEPT. 13, 1905.

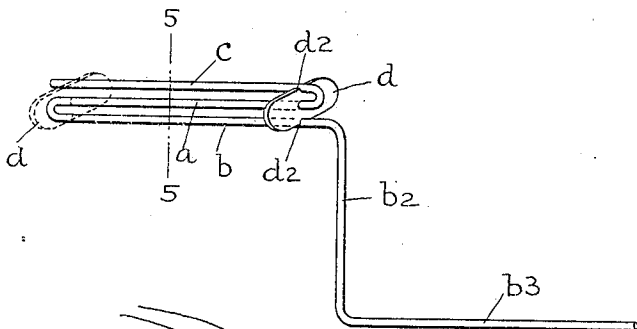

Fig. 1.

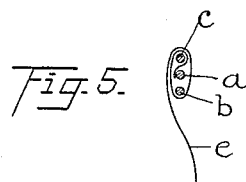
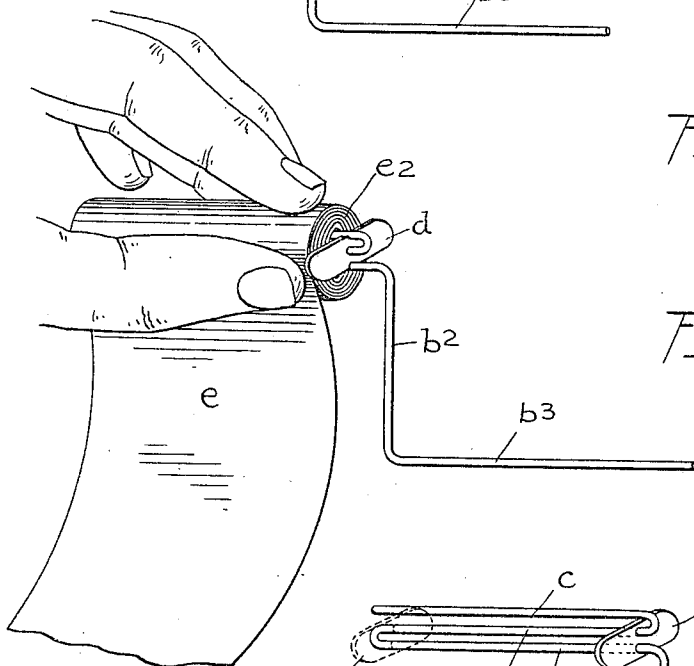

Fig. 2.

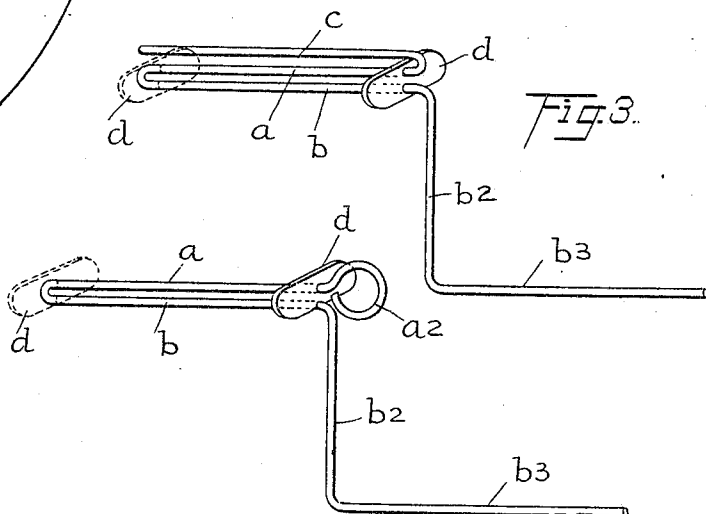

Fig. 3.

Fig. 4.

WITNESSES

*J. C. Larsen*  
*F. A. Stewart*

INVENTOR

*Louis Long*

BY

*Edgar T. Co*  
ATTORNEYS

# UNITED STATES PATENT OFFICE.

LOUIS LONG, OF BUCHANAN, NEW YORK.

## DEVICE FOR ROLLING BANDAGES.

No. 831,726.

Specification of Letters Patent.

Patented Sept. 25, 1906.

Application filed September 13, 1905. Serial No. 278,220.

*To all whom it may concern:*

Be it known that I, LOUIS LONG, a subject of the King of Italy, residing at Buchanan, in the county of Westchester and State of New York, have invented certain new and useful Improvements in Devices for Rolling Bandages, of which the following is a specification, such as will enable those skilled in the art to which it appertains to make and use the same.

This invention relates to devices for rolling bandage-strips; and the object thereof is to provide an improved device of this class by means of which bandage-strips may be quickly, easily, and conveniently rolled up whenever desired, a further object being to provide a device of this class which may be used for the purpose of rolling up ribbons, tapes, or other strips of flexible material or fabric whenever desired and wherever necessary.

The invention is fully disclosed in the following specification, of which the accompanying drawings form a part, in which the separate parts of my improvement are designated by suitable reference characters in each of the views, and in which—

Figure 1 is a perspective view of my improved bandage-rolling device; Fig. 2, a similar view showing the method of the operation thereof; Fig. 3, a view similar to Fig. 1, showing a modification; Fig. 4, another view similar to Fig. 1 and showing another modification, and Fig. 5 a section on the line 5 5 of Fig. 1 and showing the method of connecting the bandage with the roll device.

In the practice of my invention, reference being made to Figs. 1 and 2, I provide a strong wire or rod and bend it so as to form two parallel members *a* and *b*, and one of the wires or rods is then bent backwardly to form another member *c*, parallel with the member *a*, while the corresponding end of the other wire or rod is bent at right angles thereof to form a right-angled handle *b*<sup>2</sup> and *b*<sup>3</sup>, the part *b*<sup>3</sup> constituting the handle proper and the part *b*<sup>2</sup> the shank thereof.

Mounted on and slidable on the central member *a* of the winder is a transverse bar *d*, which in the form of construction shown is provided in the top and bottom edges thereof with recesses *d*<sup>2</sup> and *d*<sup>3</sup>, in which the members *c* and *b* fit. In the operation of this device in winding up a bandage or any other article of the class described, as shown in Figs. 2 and 5, one end of the bandage is inserted between the members *c* and *a* of the winder,

and the body portion of the winder, consisting of the parts *a*, *b*, and *c*, is held in one hand, so that the fingers and thumb thereof will hold the bandage in position, said bandage being shown at *e*, and the winder is turned by means of the handle *b*<sup>3</sup>. This operation of the device winds the bandage into a roll *e*<sup>2</sup>, and when the bandage is fully rolled up it is removed from the body portion of the winder by sliding the bar *d* longitudinally of the body portion of the winder to the opposite end thereof, as shown by the dotted line in Fig. 1. It will be understood that this device may be used for winding up many strips of any kind or class of material.

In Fig. 3 I have shown a modification in which the bar *d* is mounted on both of the parts *a* and *b* of the body portion of the winder, said parts *a* and *b* being passed through said bar, and this construction serves to hold the bar more steadily and prevents the turning or moving thereof in the operation of the device.

In Fig. 4 I have shown another modification in which the part *c* of the body portion of the winder is omitted, the said body portion comprising only the parallel members *a* and *b*. With this form of construction the end of the bandage is held on one of the parts *a* and *b* in starting the operation of winding a bandage; but it will be understood that the operation with this form of construction will be substantially the same as that of the construction shown in Figs. 1 and 3. In this last form of construction, however, the part *a* at its free end is formed into a ring or eye *a*<sup>2</sup>, and in practice a finger of the right hand is inserted through said ring or eye to assist in pulling the roll off of the parts *a* and *b*, which is done by moving the bar *d* to the left, as hereinbefore described.

Having fully described my invention, what I claim as new, and desire to secure by Letters Patent, is—

1. A winding device of the class described composed of a rod bent to form parallel members, a transverse bar mounted on said members and movable longitudinally thereon, one of said members being also provided with a crank-handle, substantially as shown and described.

2. A winding device of the class described composed of a rod bent to form a plurality of parallel members, two of which are connected at the opposite ends, a transversely-arranged bar mounted on one or more of said members

and movable longitudinally thereon, one of said parts being also provided at one end with a crank-handle, substantially as shown and described.

5 3. A winding device of the class described composed of a rod bent to form a plurality of parallel members, two of which are connected at the opposite ends, a transverse bar mounted on and movable longitudinally of said  
10 members, one of said members being also pro-

vided at one end with a crank-handle, substantially as shown and described.

In testimony that I claim the foregoing as my invention I have signed my name, in presence of the subscribing witnesses, this 2d day 15 of September, 1905.

LOUIS LONG.

Witnesses:

GEO. D. WHEELER,  
W. H. CLINTON.