



INTERNATIONAL APPLICATION PUBLISHED UNDER THE PATENT COOPERATION TREATY (PCT)

(51) International Patent Classification ⁶ : A61N	A2	(11) International Publication Number: WO 99/42167 (43) International Publication Date: 26 August 1999 (26.08.99)
(21) International Application Number: PCT/US98/00463 (22) International Filing Date: 7 January 1998 (07.01.98) (30) Priority Data: 08/782,471 10 January 1997 (10.01.97) US (71) Applicant: SCIMED LIFE SYSTEMS, INC. [US/US]; One Scimed Place, Maple Grove, MN 55311-1566 (US). (72) Inventor: HASTINGS, Roger, N.; 7013 Carey Lane, Maple Grove, MN 55369 (US). (74) Agents: ATKINSON, Robert, E. et al.; Westman, Champlin & Kelly, P.A., Suite 1600-International Centre, 900 Second Avenue South, Minneapolis, MN 55402-3319 (US).	(81) Designated States: CA, JP, European patent (AT, BE, CH, DE, DK, ES, FI, FR, GB, GR, IE, IT, LU, MC, NL, PT, SE). Published <i>Without international search report and to be republished upon receipt of that report.</i>	
(54) Title: INTRAVASCULAR RADIATION DELIVERY SYSTEM (57) Abstract <p>An intravascular radiation delivery system including a catheter, a radiation source disposed in an open-ended lumen in the catheter and a closed-ended sheath surrounding the radiation source so as to prevent blood and other fluids from coming into contact with the radiation source. Preferably, the open-ended lumen is centered in the balloon for uniform radiation delivery. The catheter may include a blood perfusion lumen under the balloon or around the balloon. The open-ended lumen in the catheter may have a reduced diameter adjacent the distal end of the catheter to prevent the radiation source from exiting the lumen. Methods of using the radiation delivery system are also disclosed. An alternative method of delivering radiation to a treatment site inside the vasculature of a patient using a gas-filled balloon catheter and a radiation source disposed in the balloon catheter. The treatment site is exposed to radiation, preferably beta radiation, through the gas-filled balloon.</p>		

FOR THE PURPOSES OF INFORMATION ONLY

Codes used to identify States party to the PCT on the front pages of pamphlets publishing international applications under the PCT.

AL	Albania	ES	Spain	LS	Lesotho	SI	Slovenia
AM	Armenia	FI	Finland	LT	Lithuania	SK	Slovakia
AT	Austria	FR	France	LU	Luxembourg	SN	Senegal
AU	Australia	GA	Gabon	LV	Latvia	SZ	Swaziland
AZ	Azerbaijan	GB	United Kingdom	MC	Monaco	TD	Chad
BA	Bosnia and Herzegovina	GE	Georgia	MD	Republic of Moldova	TG	Togo
BB	Barbados	GH	Ghana	MG	Madagascar	TJ	Tajikistan
BE	Belgium	GN	Guinea	MK	The former Yugoslav Republic of Macedonia	TM	Turkmenistan
BF	Burkina Faso	GR	Greece			TR	Turkey
BG	Bulgaria	HU	Hungary	ML	Mali	TT	Trinidad and Tobago
BJ	Benin	IE	Ireland	MN	Mongolia	UA	Ukraine
BR	Brazil	IL	Israel	MR	Mauritania	UG	Uganda
BY	Belarus	IS	Iceland	MW	Malawi	US	United States of America
CA	Canada	IT	Italy	MX	Mexico	UZ	Uzbekistan
CF	Central African Republic	JP	Japan	NE	Niger	VN	Viet Nam
CG	Congo	KE	Kenya	NL	Netherlands	YU	Yugoslavia
CH	Switzerland	KG	Kyrgyzstan	NO	Norway	ZW	Zimbabwe
CI	Côte d'Ivoire	KP	Democratic People's Republic of Korea	NZ	New Zealand		
CM	Cameroon			PL	Poland		
CN	China	KR	Republic of Korea	PT	Portugal		
CU	Cuba	KZ	Kazakistan	RO	Romania		
CZ	Czech Republic	LC	Saint Lucia	RU	Russian Federation		
DE	Germany	LI	Liechtenstein	SD	Sudan		
DK	Denmark	LK	Sri Lanka	SE	Sweden		
EE	Estonia	LR	Liberia	SG	Singapore		

INTRAVASCULAR RADIATION DELIVERY SYSTEMCross-Reference to Related Applications

This application is a continuation-in-part of co-pending U.S. Patent Application serial number 08/608,655 filed on February 29, 1996 entitled
5 INTRAVASCULAR RADIATION DELIVERY SYSTEM, the entire disclosure of which is incorporated herein by reference.

Field of the Invention

The present invention generally relates to intraluminal devices used to deliver radiation inside a living body. More specifically, the present invention
10 relates to intravascular devices used to deliver radiation inside the vasculature of a patient for therapeutic purposes. Those skilled in the art will recognize the benefits of applying the present invention to similar fields not discussed herein.

Background of the Invention

Intravascular diseases are commonly treated by relatively non-invasive
15 techniques such as percutaneous transluminal angioplasty (PTA) and percutaneous transluminal coronary angioplasty (PTCA). These therapeutic techniques are well-known in the art and typically involve the use of a balloon catheter with a guide wire, possibly in combination with other intravascular devices. A typical balloon catheter has an elongate shaft with a balloon attached to its distal end and a
20 manifold attached to the proximal end. In use, the balloon catheter is advanced over the guide wire such that the balloon is positioned adjacent a restriction in a diseased vessel. The balloon is then inflated and the restriction in the vessel is opened.

Vascular restrictions that have been dilated do not always remain open. For example, the restriction may redevelop over a period of time, a phenomenon
25 commonly referred to as restenosis. Various theories have been developed to explain the cause for restenosis. It is commonly believed that restenosis is caused, at least in part, by cellular proliferation over a period of time to such a degree that a stenosis is reformed in the location of the previously dilated restriction.

Intravascular radiation, including thermal, light and radioactive radiation, has
30 been proposed as a means to prevent or reduce the effects of restenosis. For example, U.S. Patent No. 4,799,479 to Spears suggests that heating a dilated restriction may prevent gradual restenosis at the dilation site. In addition, U.S.

Patent No. 5,417,653 to Sahota et al. suggests that delivering relatively low energy light, following dilatation of a stenosis, may inhibit restenosis. Furthermore, U.S. Patent No. 5,199,939 to Dake et al. suggests that intravascular delivery of radioactive radiation may be used to prevent restenosis. While most clinical studies suggest that thermal radiation and light radiation are not significantly effective in reducing restenosis, some clinical studies have indicated that intravascular delivery of radioactive radiation is a promising solution to the restenosis enigma.

Since radioactive radiation prevents restenosis but will not dilate a stenosis, radiation is preferably administered during or after dilatation. European Patent No. 0 688 580 to Verin discloses a device and method for simultaneously dilating a stenosis and delivering radioactive radiation. In particular, Verin '580 discloses balloon dilatation catheter having an open-ended lumen extending therethrough for the delivery of a radioactive guide wire.

One problem associated with the open-ended lumen design is that bodily fluids (e.g., blood) may come into contact with the radioactive guide wire. This may result in contamination of the bodily fluid and require the resterilization or disposal of the radioactive guide wire. To address these issues, U.S. Patent No. 5,503,613 to Weinberger et al. proposes the use of a separate closed-ended lumen in a balloon catheter. The closed-ended lumen may be used to deliver a radioactive guide wire without the risk of contaminating the blood and without the need to resterilize or dispose of the radiation source.

The closed-ended lumen design also has draw backs. For example, the addition of a separate delivery lumen tends to increase the overall profile of the catheter. An increase in profile is not desirable because it may reduce flow rate of fluid injections into the guide catheter and it may interfere with navigation in small vessels.

Another problem with both the open-ended and closed-ended devices is that radiation must travel through the fluid filled balloon in order to reach the treatment site. While this is not a problem for gamma radiation, it poses a significant problem for beta radiation which does not penetrate as well as gamma radiation. Beta radiation is considered a good candidate for radiation treatment because it is easy to shield and control exposure. In larger vessels (e.g., 0.5 cm or larger), a fluid filled

balloon absorbs a significant amount of beta radiation and severely limits exposure to the treatment site.

Summary of the Invention

The present invention overcomes these problems by providing a radiation
5 delivery system that permits the use of an open-ended delivery lumen without the risk of blood contamination and without the need to dispose of or resterilize the radiation source. In addition, the present invention provides a radiation delivery system that permits beta radiation to be delivered through a balloon without a significant decrease in radiation exposure to the treatment site, even in large vessels.

10 One embodiment of the present invention may be described as a catheter having an open-ended lumen, a radiation source disposed in the open-ended lumen of the catheter and a closed-end sheath surrounding the radiation source. The closed-end sheath prevents blood and other fluids from coming into contact with the radiation source so that blood is not contaminated and the radiation source may be
15 reused. The catheter may be a balloon catheter and may include a guide wire disposed in the open-ended lumen of the catheter. The open-ended lumen may be a full-length lumen or a partial-length lumen (e.g., a rapid exchange lumen). Preferably, the lumen is centered in the balloon for uniform radiation delivery. The catheter may also include a blood perfusion lumen under the balloon or around the
20 balloon. The open-ended lumen in the catheter may have a reduced diameter adjacent the distal end of the catheter to prevent the radiation source from exiting the lumen. Alternatively, the closed-end sheath may have a ridge which abuts a corresponding restriction in the open-end lumen of the catheter to prevent the radiation source from exiting the lumen.

25 Another embodiment of the present invention may be described as a method of delivering radiation to a treatment site inside the vasculature of a patient using a the radiation delivery system described above wherein the method includes the steps of (1) inserting the catheter into the vasculature of a patient; (2) inserting the radiation source into the closed-end sheath; (3) inserting the radiation source and the
30 closed-end sheath into the lumen of the catheter such that the radioactive portion is positioned adjacent a treatment site; and (3) exposing the vascular wall to radiation from the radiation source. Alternatively, the sheath may be inserted into the

catheter before the radiation source is loaded into the sheath. The method may also include the steps of (4) removing the radiation source from the catheter; and (5) removing the catheter from the patient. The catheter may be inserted into the vasculature over a guide wire and the guide wire may be removed from the catheter prior to exposing the vascular wall to radiation.

Yet another embodiment of the present invention may be described as a method of delivering radiation to a treatment site inside the vasculature of a patient using a gas-filled balloon catheter and a radiation source wherein the method includes the steps of: (1) inserting the catheter into the vasculature such that the balloon is adjacent to a treatment site; (2) inserting the radiation source into the catheter such that the radioactive portion is adjacent to the balloon; (3) inflating the balloon with a gas; and (4) exposing the treatment site to radiation from the radiation source through the gas in the balloon. The balloon may be inflated prior to or subsequent to inserting the radiation source. Preferably beta radiation is used, but other radioisotopes may be employed.

Brief Description of the Drawings

Figure 1 is a partially sectioned side view of an embodiment of the present invention.

Figure 2 is a cross-sectional view taken at A-A in Figure 1.

Figure 3 is a side view of an alternative embodiment of the present invention including a helical-shaped balloon.

Figure 4 is a side view of an alternative embodiment of the present invention including a toroidal-serpentine-shaped balloon.

Figures 5a, 5b and 5c are partially sectioned side views of an alternative embodiment of the present invention including a rapid-exchange guide wire lumen.

Figure 6 is a partially sectioned side view of an alternative embodiment of the present invention including a perfusion lumen passing through the balloon.

Figure 7 is a cross-sectional view taken at B-B in Figure 6.

Figure 8 is a cross-sectioned side view of an alternative sheath of the present invention.

Detailed Description of the Invention

The following detailed description should be read with reference to the drawings in which similar parts in different drawings are numbered the same. The drawings, which are not necessarily to scale, depict exemplary embodiments and are not intended to limit the scope of the invention.

5 Examples of suitable materials, dimensions, parts, assemblies, manufacturing processes and methods of use are described for each embodiment. Otherwise, that which is conventional in the field of the invention may be implemented. Those skilled in the field will recognize that many of the examples provided have suitable alternatives which may also be utilized.

10 Refer now to Figures 1 and 2 which illustrate a radiation delivery system 10 of the present invention. Radiation delivery system 10 includes a catheter 11 having an open-ended lumen 12 extending therethrough. A closed-ended sheath 13 surrounds a radiation source 14 (such as a guide wire) disposed in the open-ended lumen 12. An after-loader 22 may be connected to the proximal end of the radiation source 14
15 to advance and retract the radiation source 14 and safely contain it when not in use.

 The catheter 11 includes an inflatable balloon 15 having an interior 16 which is in fluid communication with an inflation lumen 17. The catheter 11 illustrated in Figures 1 and 2 has a coaxial shaft construction including an inner tube 23 and an
20 outer tube 24. Other shaft constructions may be employed such as a dual lumen shaft design illustrated in Figure 6. A manifold 18 is connected to the proximal end of the catheter 11 and includes a guide wire port 19 and a flush port 20 both of which are in fluid communication with the open-ended lumen 12. The guide wire port may include a toughy-borst (not shown) to seal about the proximal end of the closed-end sheath 13. The manifold 18 also includes an inflation port 21 which is in fluid
25 communication with the inflation lumen 17 and the interior 16 of the balloon 15.

 The closed-end sheath 13 preferably extends to the proximal end of the catheter 11 and may include means for connection to the after-loader 22. The closed-end sheath 13 may be formed of polyethylene, PTFE coated polyimide or other
30 suitable flexible material. The closed-end sheath 13 may have a length of about 100 to 300 cm depending on the length of the catheter 11. A wall thickness between 0.0002 and 0.005 inches is preferred to minimize profile and radiation absorption.

As included with catheter 11 illustrated in Figures 1 and 2, the open-ended lumen 12, closed-ended sheath 13, radiation source 14, after loader 22 and toughy-borst are also included with catheters 31, 41, 51 and 61 as illustrated in Figures 3, 4, 5 and 6 respectively. In addition, those skilled in the art will appreciate that the various features of each catheter 11, 31, 41, 51 and 61 may be mixed and matched depending on the desired result. For example, the rapid exchange features of catheter 51 may be incorporated into perfusion catheter 61, resulting in a perfusion rapid exchange catheter for the delivery of radiation. As another example, the centering balloon 35 or 45 may be contained inside balloon 15 of catheters 11 and 61 to provide a centering function, even in curved vasculature.

Refer now to Figures 3 and 4 which illustrate alternative radiation delivery catheters 31 and 41. Alternative catheters 31 and 41 may be used in place of catheter 11 for the radiation delivery system 10 illustrated in Figure 1. Except as described herein, the design and use of alternative catheters 31 and 41 is the same as catheter 11. Alternative catheter 41 may be made as described in co-pending U.S. Patent Application serial number 08/608,655 which is incorporated herein by reference. Similarly, alternative catheter 31 may be made as described in the above-referenced case except that the balloon 35 is wound in a helical shape rather than a serpentine shape.

With reference to Figure 3, alternative catheter 31 includes a helically-shaped balloon 35 which is wound around the distal end of the catheter 31. When the helically-shaped balloon 35 is inflated, a helically-shaped perfusion path 36 is defined between the balloon 35, the shaft 37 and the inside surface of the blood vessel. The blood perfusion path 36 allows blood to flow across the treatment site while the balloon 35 is inflated. In addition, the concentric and flexible helical shape of the inflated balloon 35 maintains the distal portion of the catheter 31 centered in the vessel, even around turns in the vasculature. Having the catheter 31 centered in a vessel permits the uniform distribution of radiation to the treatment site.

The distal end of the shaft 37 may include a reduced diameter tip 38 with a corresponding reduced inside diameter open-ended lumen (not visible). The reduced inside diameter permits a conventional guide wire to exit out the distal end of the catheter 31 but prohibits the sheath 13 and radioactive source wire 14 from

exiting. This assumes, of course, that the sheath 13 or radioactive source wire 14 is larger than the guide wire. A reduced diameter tip may be included on any of the catheters described herein.

With reference to Figure 4, alternative catheter 41 includes a toroidal-
5 serpentine-shaped balloon 45. When the serpentine-shaped balloon 45 is inflated, a linear perfusion path 44 is defined between the balloon 45, the shaft 47 and the inside surface of the blood vessel. The blood perfusion path 44 allows blood to flow across the treatment site while the balloon 45 is inflated. As with the helical balloon described above, the concentric and flexible serpentine shape of the inflated balloon
10 45 maintains the distal portion of the catheter 41 centered in the vessel, even around turns in the vasculature. Having the catheter 41 centered in a vessel permits the uniform distribution of radiation to the treatment site. A further advantage of the serpentine-shaped balloon 45 is the relative linearity of the perfusion path 44 which tends to minimize resistance to blood flow.

15 Catheter 41 may also include two radiopaque markers 46 to facilitate radiographic placement in the vasculature. The distal end of the shaft 47 may include a reduced diameter tip 48 with a corresponding reduced inside diameter open-ended lumen (not visible). The reduced inside diameter permits a conventional guide wire to exit out the distal end of the catheter 41 but prohibits the
20 sheath 13 and radioactive source wire 14 from exiting.

It is also contemplated that both the helical balloon 35 and the serpentine balloon 45 may be covered with an elastomeric sleeve to aid in collapsing the balloon 35/45 upon deflation. This sleeve would be connected to the shaft adjacent the proximal and distal ends of the balloon 35/45. It is further contemplated that this
25 sleeve may include perfusion holes both proximally and distally to permit blood perfusion along the perfusion path 36/44 defined by the balloon 35/45. If a gas is used to inflate the balloon 35/45 in large diameter vessels (e.g., peripheral vasculature), it is preferred to not permit perfusion of blood which would otherwise absorb beta radiation. In such a situation, the sleeve would not include perfusion
30 holes.

Refer now to Figures 5a, 5b and 5c which illustrate a rapid-exchange embodiment of the present invention. Alternative catheter 51 may be used in place

of catheter 11 for the radiation delivery system 10 illustrated in Figure 1. Except as described herein, the design and use of alternative catheter 51 is the same as catheter 11.

Rapid-exchange catheter 51 includes an elongate shaft 57 with a manifold 52 connected to the proximal end and a balloon 45 connected to the distal end. Although catheter 51 is shown with a serpentine balloon 45 and a corresponding linear perfusion path 44, any of the balloon types described herein may be used.

The manifold 52 includes a balloon inflation port 53 which is in fluid communication with the balloon 45 via a conventional inflation lumen. A radiation source entry port 54 is also included in the manifold 52. The entry port 54 communicates with the open-ended lumen and permits the insertion of the sheath 13 and radiation source 14. The open-ended lumen terminates in a reduced diameter tip 58 which permits a conventional guide wire 56 to exit out the distal end of the catheter 51 but prohibits the sheath 13 and radioactive source wire 14 from exiting.

The guide wire 56 enters the shaft 57 at the proximal guide wire tube 55. The guide wire tube 55 is located near the distal end of the catheter to permit catheter exchange without the need for an extension wire or wire trapping device. As best seen in Figure 5c, the guide wire tube 55 has sufficient length such that the guide wire 56 may be pulled back and out of the open-ended lumen. In particular, the distance from the proximal end of the guide wire tube 55 to the distal end of the catheter 51 is less than the length of the guide wire extending outside of the patient's body. With the guide wire pulled back, the radioactive source wire 14 and the sheath 13 may be inserted into the entry port 54 to the distal end of the catheter 51.

Refer now to Figures 6 and 7 which illustrate an alternative perfusion catheter 61. Alternative catheter 61 may be used in place of catheter 11 for the radiation delivery system 10 illustrated in Figure 1. Except as described herein, the design and use of alternative catheter 61 is the same as catheter 11.

Perfusion catheter 61 includes an elongate shaft 67 with a manifold 18 connected to the proximal end and a balloon 16 connected to the distal end. The shaft 67 is a multi-lumen type extrusion including an open-ended lumen 62 and an inflation lumen 63. Inflation lumen 63 provides fluid communication between the inflation port 21 and the interior of the balloon 16. Open ended lumen 62 is in

communication with entry port 19 for the insertion of a guide wire (not shown) or the radioactive source 14 and sheath 13. A guide wire extension tube 64 is connected to the distal end of the multi-lumen shaft 67 and rigidly connects to the distal end of the balloon 15.

5 Catheter 61 includes a series of perfusion ports 65 which are in fluid communication with the distal portion of the open-ended lumen 62. The perfusion ports 65 permit blood to flow across the treatment site via the open-ended lumen while the balloon 15 is inflated.

With reference now to Figure 8, an alternative sheath 81 is illustrated.

10 Alternative sheath 81 may be used in place of sheath 13 for the radiation delivery system 10 illustrated in Figure 1. Except as described herein, the design and use of alternative sheath 81 is the same as sheath 13.

Sheath 81 includes a proximal portion 82 and a distal portion 83, wherein the proximal portion 82 includes a relatively thicker wall and larger outside diameter. The thicker wall tends to absorb radiation to reduce the amount of unwanted exposure, particularly exposure of the medical personnel. The larger outside diameter of the proximal portion 84 may be used in conjunction with a corresponding restriction in the open-ended lumen 12 of any of the catheters described herein. Specifically, the leading edge or ridge 86 of the proximal portion 82 may abut a mating restriction in the open-ended lumen 12 such that the sheath 81 cannot be advanced beyond that point. The leading edge 86 and the mating restriction in the open-ended lumen serve the same function as the reduced diameter tip described previously and may be used in lieu thereof. In other words, the leading edge 86 and the mating restriction in the open-ended lumen would permit a conventional guide wire 56 to exit out the distal end of the catheter but would prohibit the sheath 81 and radioactive source wire 14 from exiting the distal end of the catheter.

25 The closed-end sheath 81 may include means for connection to the after-loader 22. The closed-end sheath 81 may be formed of polyethylene, PTFE coated polyimide or other suitable flexible material. The closed-end sheath 81 may have a length of about 100 to 300 cm depending on the length of the catheter 11. On the distal portion 83, a wall thickness between 0.0002 and 0.005 inches is preferred to

minimize profile and radiation absorption. On the proximal portion 82, a wall thickness between 0.040 and 1.0 inches is preferred to maximize radiation absorption without significantly compromising profile. The outside diameter of the proximal portion 82 may be greater than the vascular access size on the portion of the sheath 81 that remains outside the body. Once the radiation source is inside the body, the risk of exposure of beta radiation to medical personnel is diminished.

Sheath 81 may also include a radiopaque marker 84 to facilitate radiographic placement of the sheath 81 and radioactive wire 14. Such a radiopaque marker 84 may also be included on sheath 13.

Sheath 81 may also include a series of annular magnets 85. Magnets 85 may be used to interact with a series of magnets connected to the catheter 11, 31, 41, 51 or 61 or a series of magnets connected to a guide catheter (not shown). This general arrangement is described in more detail in PCT publication WO 95/21566 which is fully incorporated herein by reference. The interacting magnets provide a means to longitudinally control and stabilize the position of the radiation source relative to the patient and treatment site.

In practice, catheters 11, 31, 41, 51 and 61 may be used to deliver radiation to the vascular wall in the following manner. After vascular access is established and a guide catheter is in position (if desired), the catheter 11/31/41/51/61 is inserted into the patient with the distal portion adjacent the treatment site. If a guide wire is used, the guide wire may be inserted prior to or simultaneously with the catheter. The balloon is then inflated to a low pressure sufficient to center the balloon in the vasculature and prevent movement of the catheter relative to the treatment site. Optionally, the balloon may first be inflated to a higher pressure in order to dilate the treatment site. If desired, the balloon may be inflated with a gas such as nitrogen, carbon dioxide or other non-toxic gas to minimize the absorption of radiation by the inflation media. After dilatation, the balloon is maintained in an inflated state, preferably at a low pressure, to center the catheter in the vascular lumen. The sheath 13 is placed over the radiation wire 14, preferably ahead of time, and the two are advanced into the open-ended lumen using an after-loader system. Optionally, the sheath 13 is first loaded into the open-ended lumen of the catheter and the proximal end of the sheath is connected to the after-loader, followed by

insertion of the radioactive source wire 14. The toughy-borst is maintained sufficiently loose to allow advancement and may be locked to fully seal about the sheath 13 once the radiation wire 14 and sheath 13 are in the desired position. If a guide wire is used in the open-ended lumen, the guide wire is preferably retracted to permit passage of the radioactive wire 14 and sheath 13. If a rapid exchange catheter 51 is used, the guide wire is pulled back into the proximal guide wire tube 55. The vascular wall is then exposed to radiation (preferably beta radiation) for the desired period of time. The radioactive wire 14 and sheath 13 are removed from the catheter 11/31/41/51/61 and the catheter is removed from the patient.

While the specification describes the preferred embodiments, those skilled in the art will appreciate the spirit and scope of the invention with reference to the appended claims. Claims directed to methods of the present invention may be read without regard as to the order of the steps unless contraindicated by the teachings herein.

WHAT IS CLAIMED IS:

1. An intravascular radiation delivery system, comprising:
 - a. a catheter having a proximal end, a distal end, an exterior and an open-ended lumen extending therethrough, the open-ended lumen being in fluid communication with the exterior of the catheter;
 - b. an elongate radiation source having a proximal end, a distal end and a radioactive portion adjacent the distal end, the elongate radiation source disposed in the open-ended lumen of the catheter; and
 - c. a closed-ended sheath disposed in the open-ended lumen of the catheter and about the elongate radiation source so as to prevent fluid communication between the radiation source and the open-ended lumen.
2. A radiation delivery system as in claim 1, wherein the catheter includes an inflatable balloon disposed about the distal end of the catheter, the balloon having an interior.
3. A radiation delivery system as in claim 2, wherein the catheter includes an inflation lumen extending therethrough, the inflation lumen communicating with the interior of the balloon.
4. A radiation delivery system as in claim 3, further comprising a guide wire, the guide wire extending through the open-ended lumen of the catheter.
5. A radiation delivery system as in claim 4, wherein the open-ended lumen extends through a portion of the length of the catheter.
6. A radiation delivery system as in claim 4, wherein the open-ended lumen extends through the entire length of the catheter.

7. A radiation delivery system as in claim 2, wherein the catheter includes a blood perfusion lumen.
8. A radiation delivery system as in claim 7, wherein the perfusion lumen extends through the balloon.
9. A radiation delivery system as in claim 2, wherein the open-ended lumen is centered in the interior of the balloon.
10. A radiation delivery system as in claim 9, wherein the balloon is helical-shaped.
11. A radiation delivery system as in claim 9, wherein the balloon is toroidal-serpentine-shaped.
12. A radiation delivery system as in claim 9, 10 or 11, wherein the catheter includes a blood perfusion lumen.
13. A radiation delivery system as in claim 12, wherein the perfusion lumen extends through the balloon.
14. A radiation delivery system as in claim 12, wherein the open-ended lumen has a reduced diameter adjacent the distal end of the catheter.
15. A radiation delivery system as in claim 14, wherein the radiation source has a distal profile and the reduced diameter of the open-ended lumen is less than the distal profile of the radiation source.
16. A method of delivering radiation to a treatment site inside the vasculature of a patient, the method comprising the steps of:
 - a. providing a catheter having a proximal end, a distal end, an exterior and an open-ended lumen extending therethrough, the

- open-ended lumen being in fluid communication with the exterior of the catheter;
- b. providing an elongate radiation source having a proximal end, a distal end and a radioactive portion adjacent the distal end;
 - c. providing a closed-end sheath;
 - d. inserting the catheter into the vasculature of a patient;
 - e. inserting the elongate radiation source into the closed-end sheath;
 - f. inserting the radiation source and the closed-end sheath into the open-ended lumen of the catheter such that the radioactive portion is positioned adjacent a treatment site; and
 - g. exposing the vascular wall to radiation from the radiation source.
17. A method of delivering radiation as in claim 16, the method further comprising the steps of:
- h. removing the radiation source from the catheter; and
 - i. removing the catheter from the patient.
18. A method of delivering radiation as in claim 17, wherein the radiation source and the catheter are removed from the patient at the same time.
19. A method of delivering radiation as in claim 16, wherein the catheter is inserted into the vasculature over a guide wire.
20. A method of delivering radiation as in claim 19, wherein the guide wire is removed from the catheter prior to exposing the vascular wall to radiation.
21. A method of delivering radiation to a treatment site inside the vasculature of a patient, the method comprising the steps of:
- a. providing a catheter having a distal end and a balloon mounted on the distal end;

- b. providing a radiation source having a distal end and a radioactive portion adjacent the distal end;
 - c. inserting the catheter into the vasculature of a patient such that the balloon is adjacent to a treatment site;
 - d. inserting the radiation source into the catheter such that the radioactive portion is adjacent to the balloon;
 - e. inflating the balloon with a gas;
 - f. exposing the treatment site to radiation from the radiation source through the gas in the balloon.
22. A method of delivering radiation as in claim 21, wherein the radioactive source emits a beta isotope.
23. A method of delivering radiation as in claim 22, wherein the balloon is inflated prior to inserting the radiation source.
24. A method of delivering radiation as in claim 22, wherein the balloon is inflated subsequent to inserting the radiation source.
25. An intravascular radiation delivery system as in claim 1 wherein the closed-end sheath has a thicker wall proximal portion relative to a thinner wall distal portion such that the proximal portion shields radiation before the radiation source is positioned inside the patient.
26. An intravascular radiation delivery system as in claim 1 wherein the closed-end sheath has a ridge or edge at a point proximal of the distal end of the sheath to prohibit the sheath from exiting the catheter.
27. A method of delivering radiation to a treatment site inside the vasculature of a patient, the method comprising the steps of:
- a. providing a catheter having a proximal end, a distal end, an exterior and an open-ended lumen extending therethrough, the

- open-ended lumen being in fluid communication with the exterior of the catheter;
- b. providing an elongate radiation source having a proximal end, a distal end and a radioactive portion adjacent the distal end;
 - c. providing a closed-end sheath;
 - d. inserting the catheter into the vasculature of a patient;
 - e. inserting the closed-end sheath into the open-ended lumen of the catheter;
 - f. inserting the radiation source into the sheath such that the radioactive portion is positioned adjacent a treatment site; and
 - g. exposing the vascular wall to radiation from the radiation source.
28. A method of delivering radiation as in claim 27, the method further comprising the steps of:
- h. removing the radiation source from the sheath; and
 - i. removing the sheath from the catheter.
29. A method of delivering radiation as in claim 28, the method further comprising the step of:
- j. removing the catheter from the patient.
30. A method of delivering radiation as in claim 27, wherein the catheter is inserted into the vasculature over a guide wire.
31. A method of delivering radiation as in claim 30, wherein the guide wire is removed from the catheter prior to exposing the vascular wall to radiation.
32. A method of delivering radiation as in claim 29, wherein the catheter is removed from the patient over a guide wire.

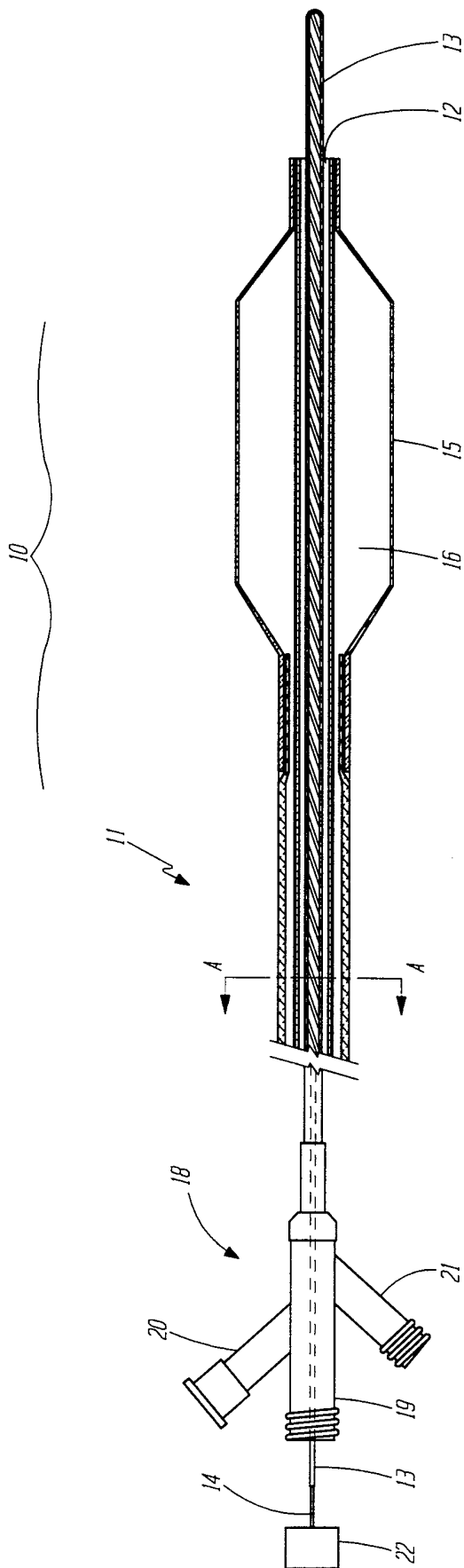

FIGURE 1

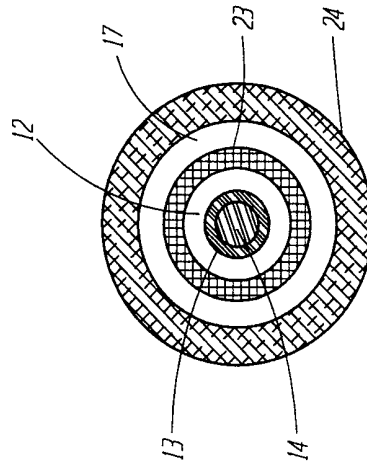

FIGURE 2

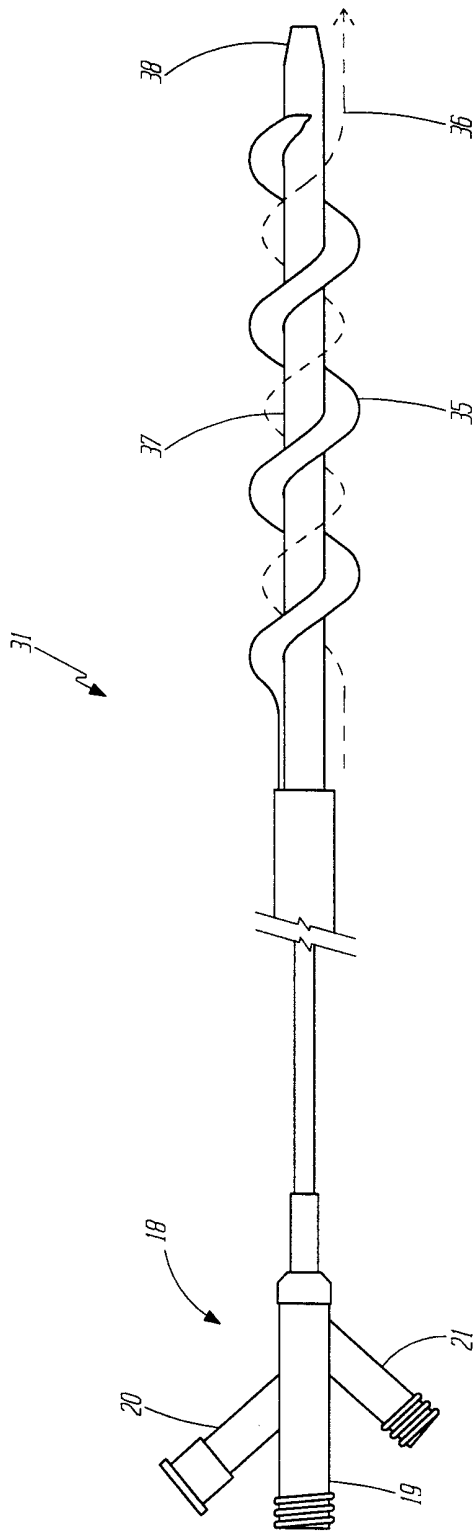

FIGURE 3

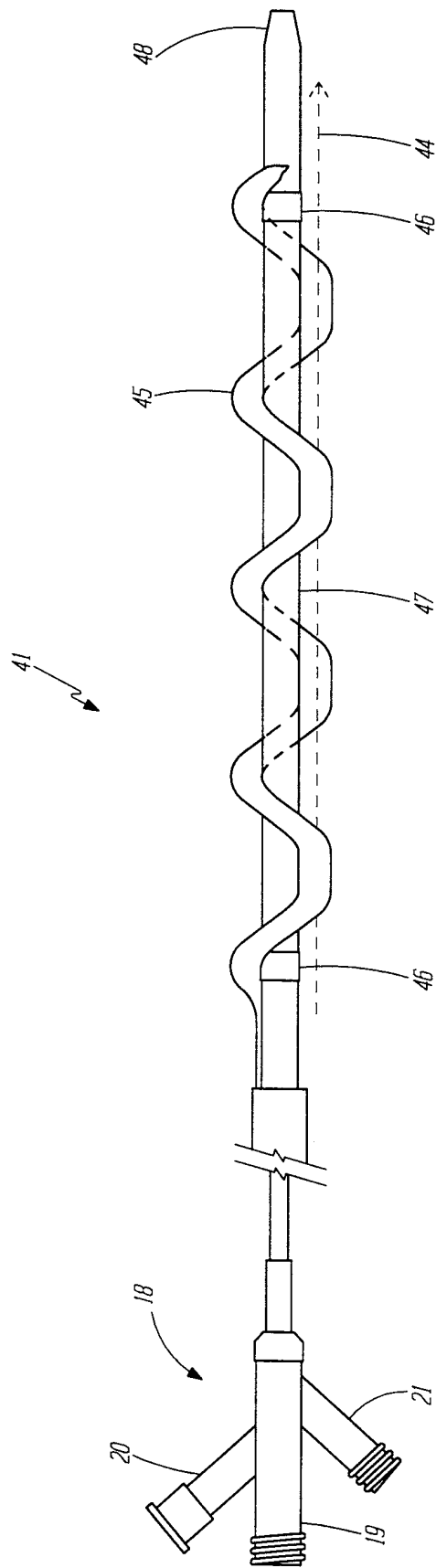

FIGURE 4

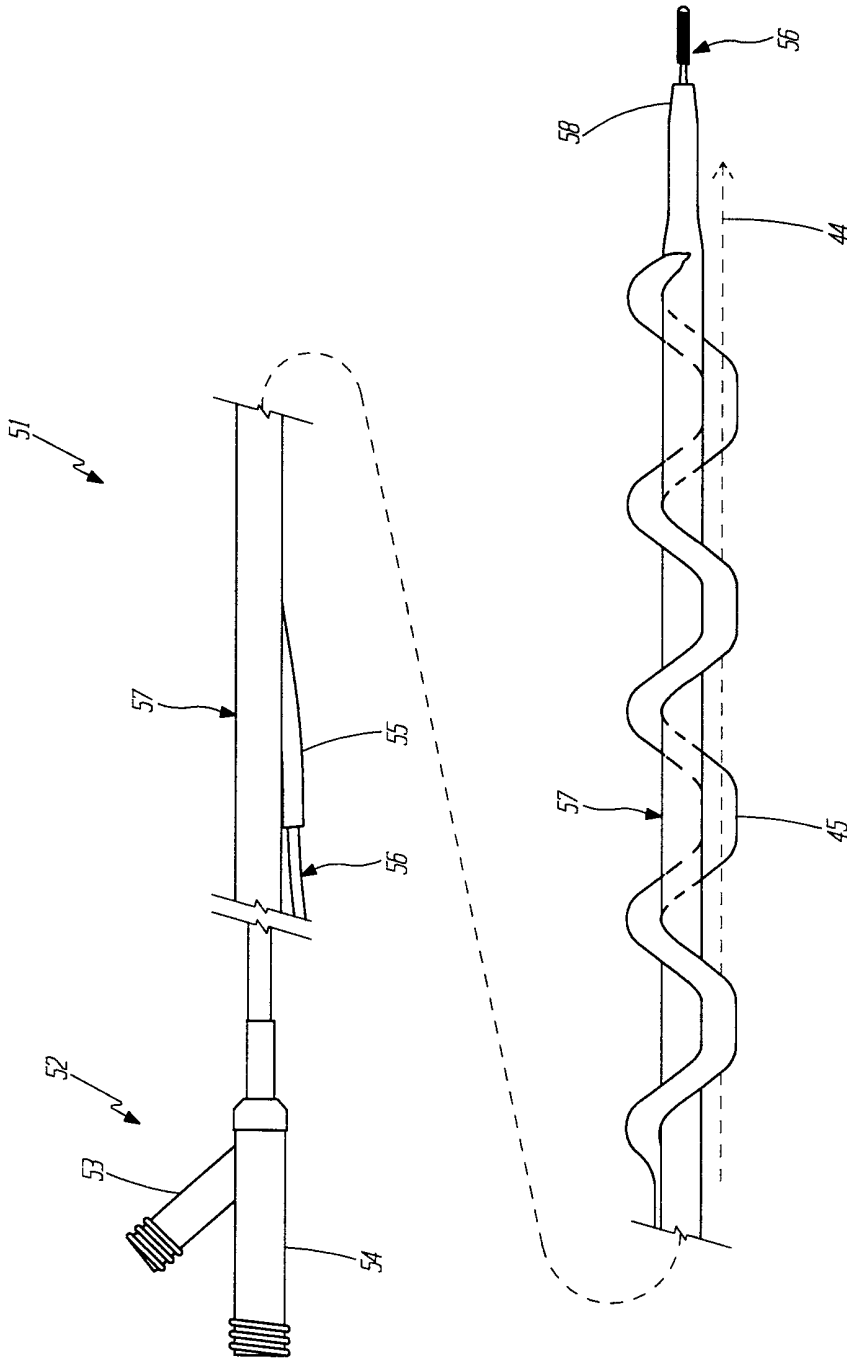

FIGURE 5a

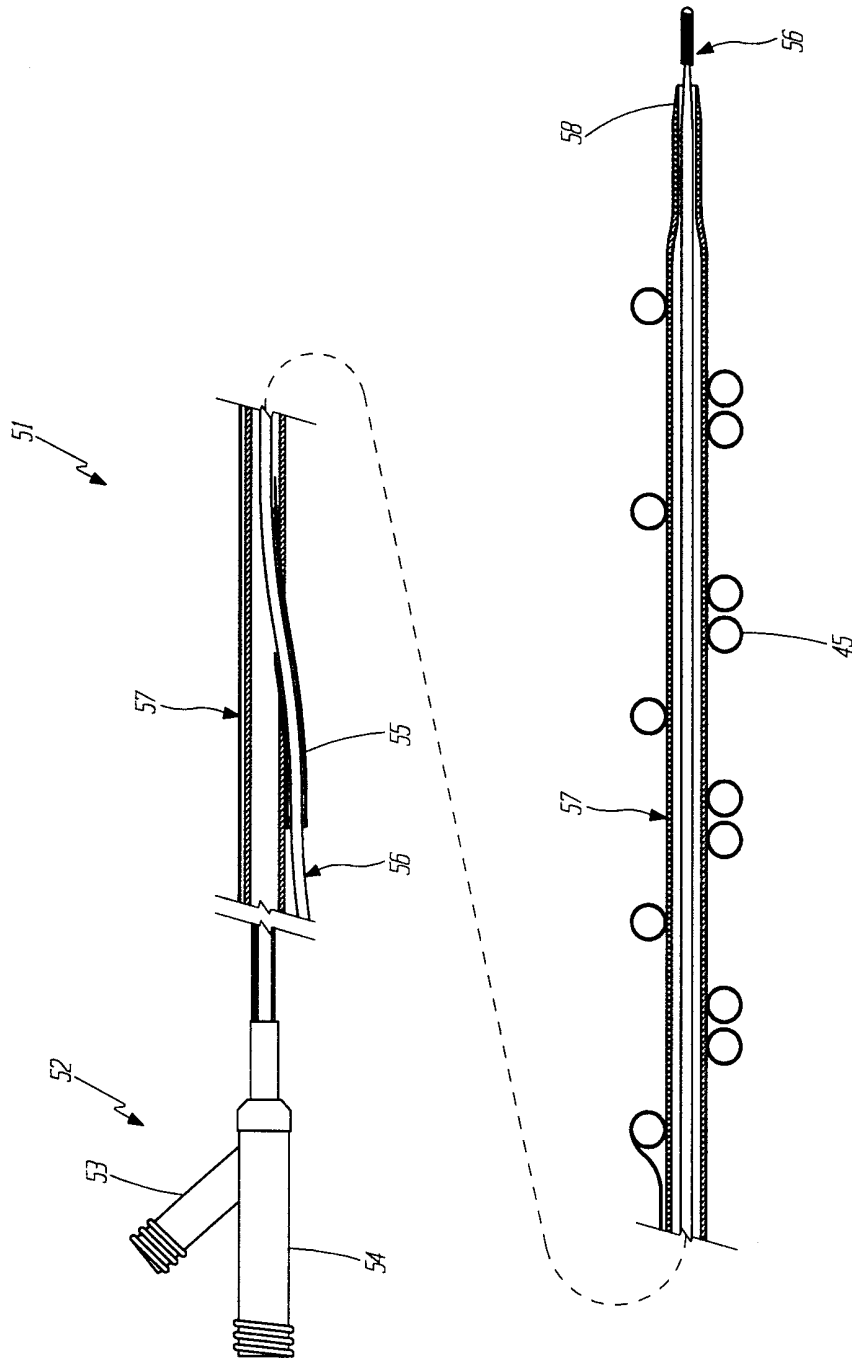

FIGURE 5b

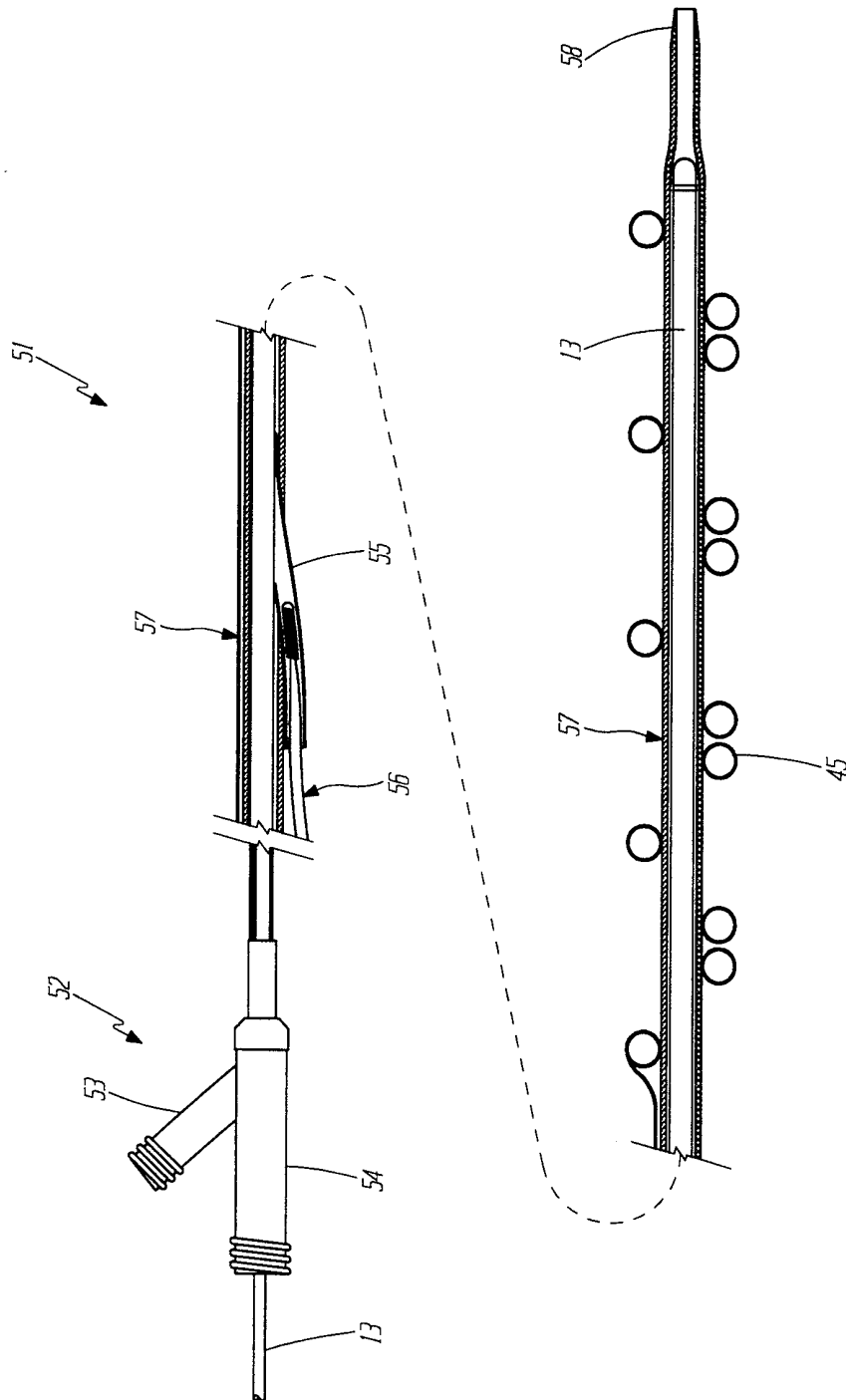

FIGURE 5C

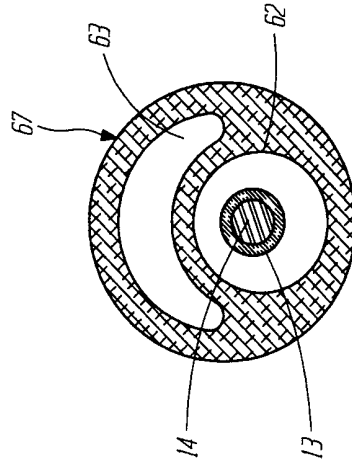
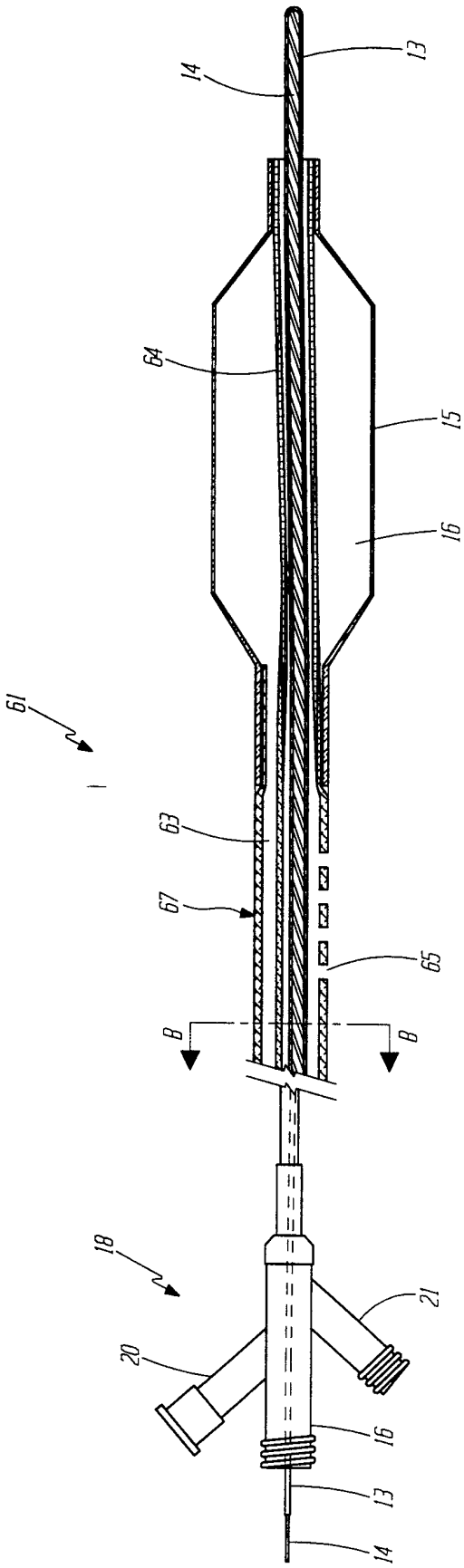

FIGURE 6

FIGURE 7

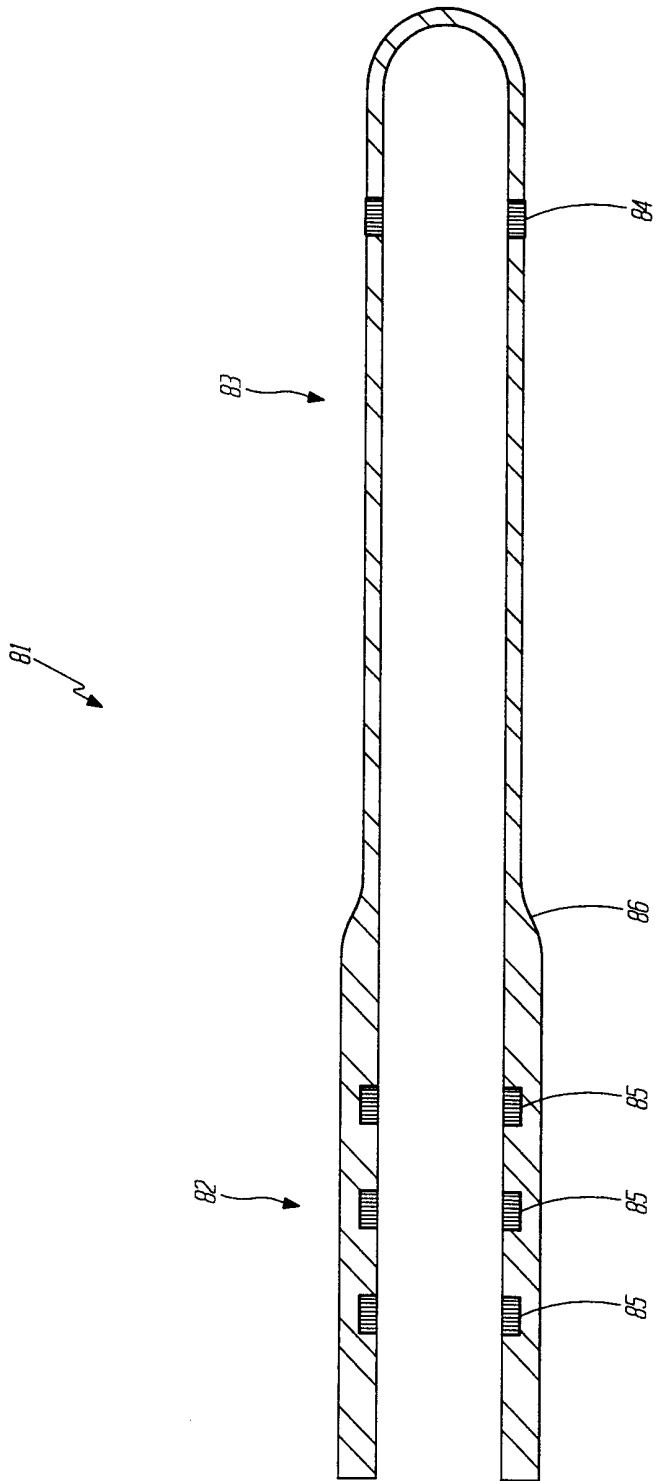

FIGURE 8