

C. J. HAGSTROM.
 DOOR OR WINDOW FASTENER.
 APPLICATION FILED MAY 4, 1912.

1,060,251.

Patented Apr. 29, 1913.

6 SHEETS-SHEET 1.

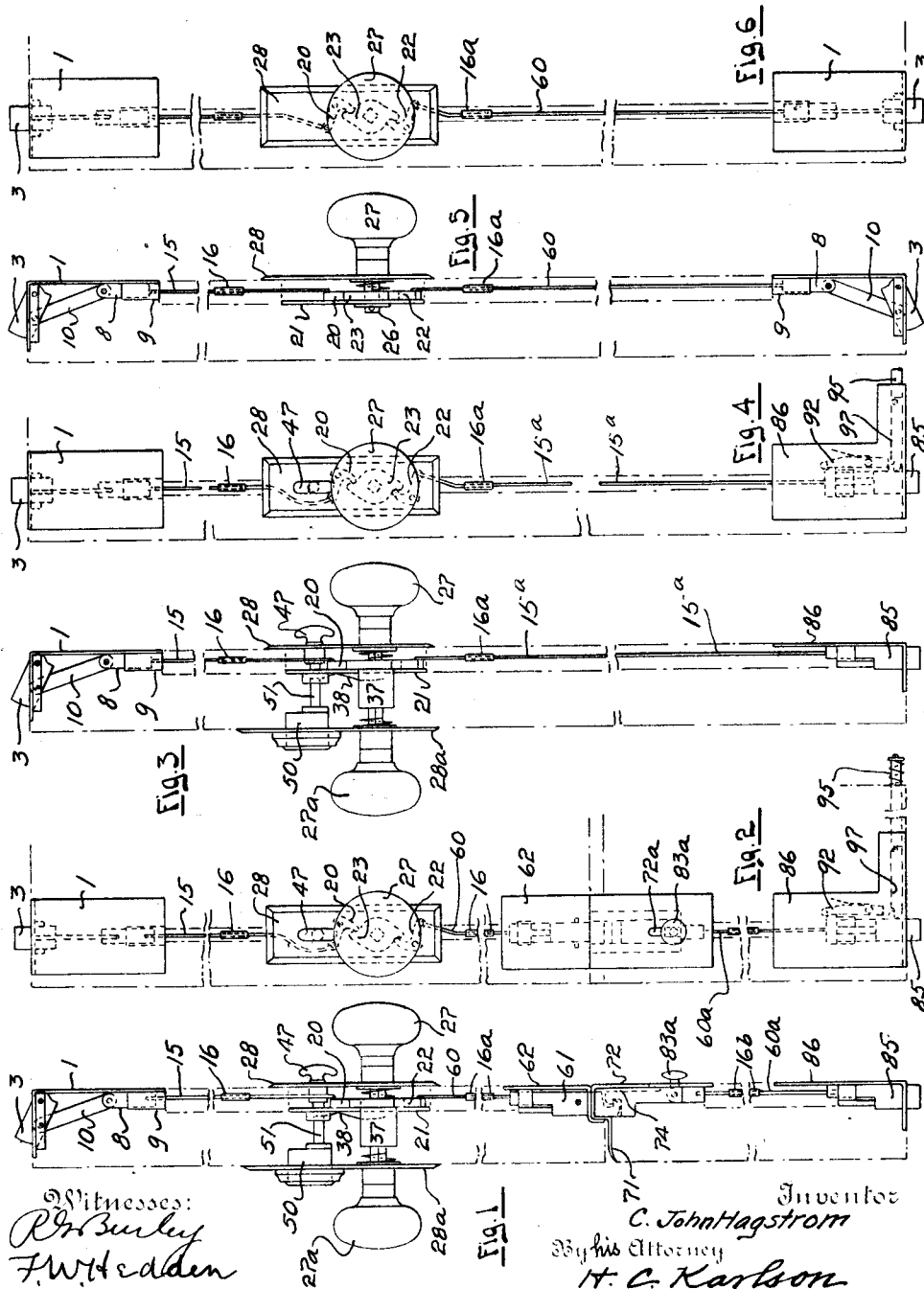

Witnesses:
R. B. Burley
F. W. Hadden

Inventor
C. John Hagstrom
 By his Attorney
H. C. Carlson

C. J. HAGSTROM.
 DOOR OR WINDOW FASTENER.
 APPLICATION FILED MAY 4, 1912

1,060,251.

Patented Apr. 29, 1913.

5 SHEETS—SHEET 2.

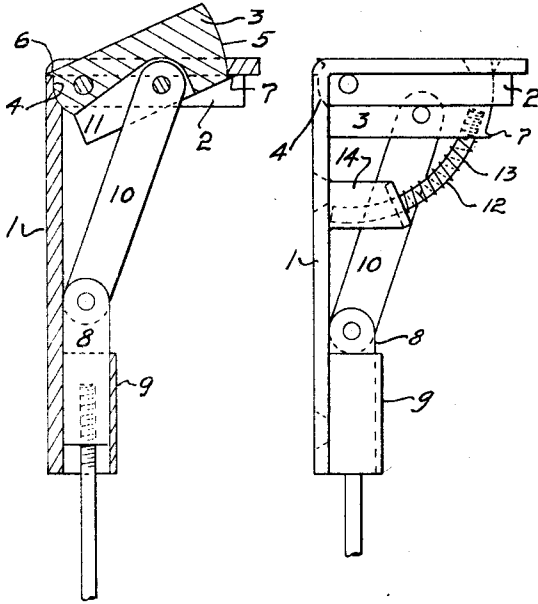

Fig. 9

Fig. 8

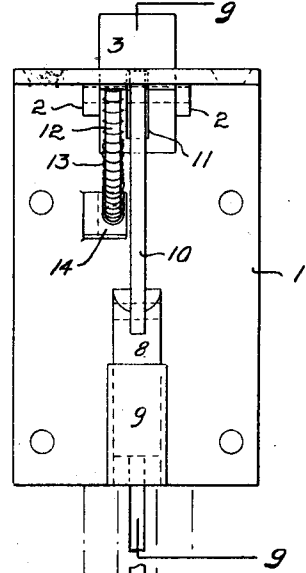

Fig. 7

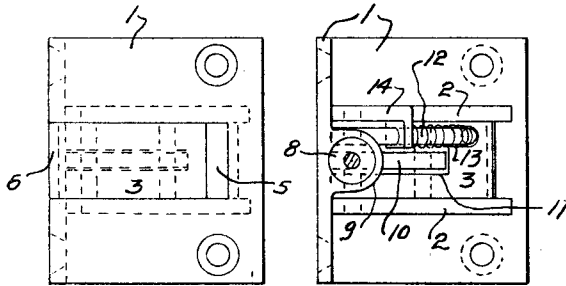
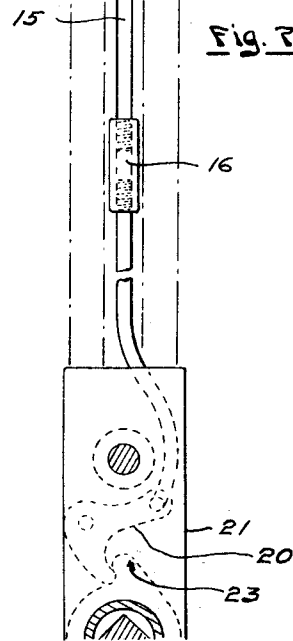

Fig. 10

Fig. 11



Witnesses:
R. B. Bailey
F. W. Hedden

Inventor
C. John Hagstrom
 By his Attorney
H. C. Carlson

C. J. HAGSTROM.
 DOOR OR WINDOW FASTENER.
 APPLICATION FILED MAY 4, 1912.

1,060,251.

Patented Apr. 29, 1913.

6 SHEETS—SHEET 3.

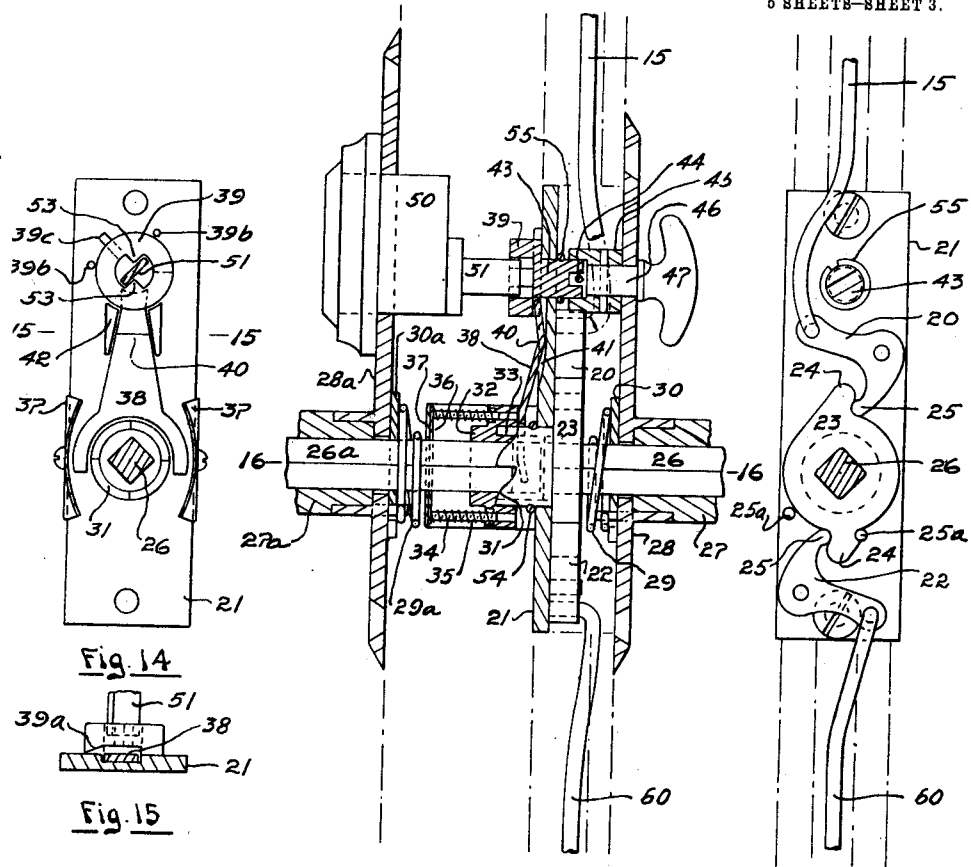

Fig. 14

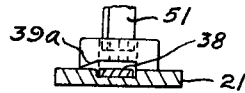

Fig. 15

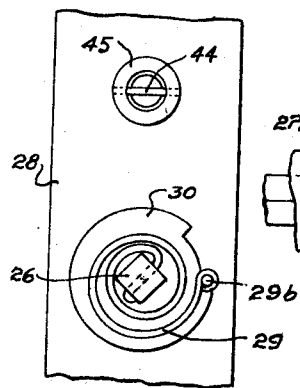

Fig. 17

Witnesses:
R. B. Beasley
W. H. Hadden

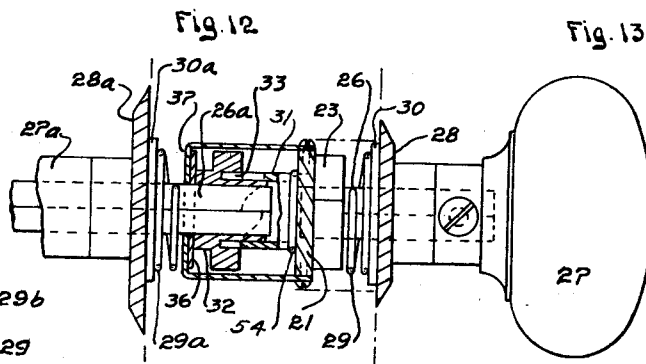

Fig. 16

Inventor
C. John Hagstrom
 By his Attorney
H. C. Karlson

C. J. HAGSTROM.
 DOOR OR WINDOW FASTENER.
 APPLICATION FILED MAY 4, 1912

1,060,251.

Patented Apr. 29, 1913.

5 SHEETS—SHEET 4.

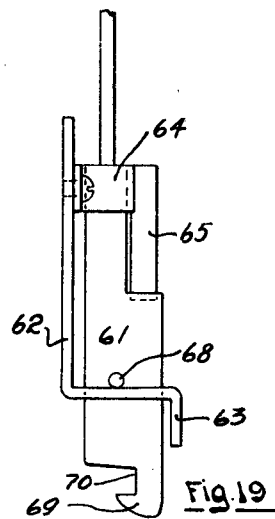

Fig. 19

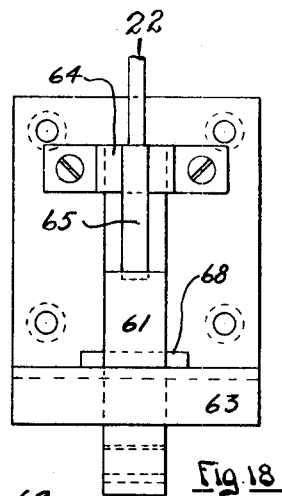

Fig. 18

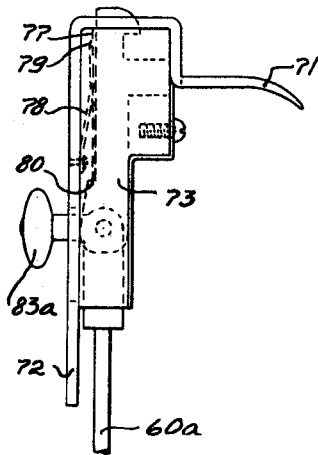

Fig. 21

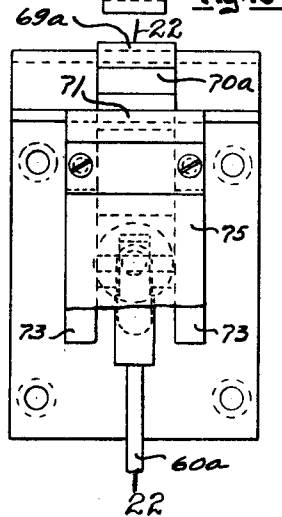

Fig. 20

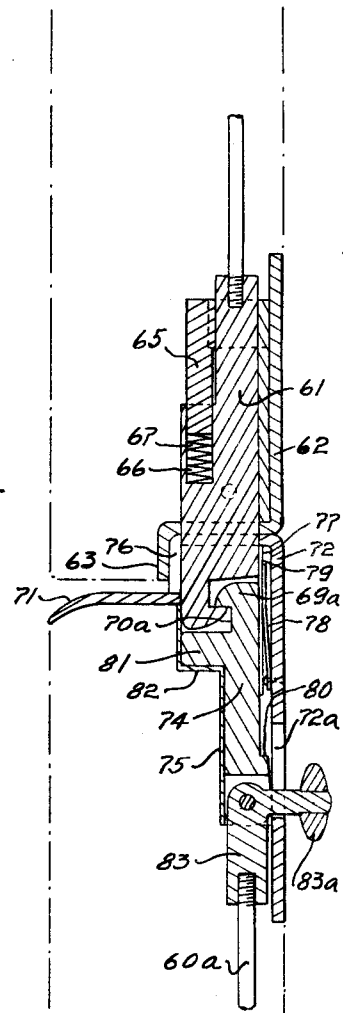

Fig. 22

Witnesses:
J. S. Smiley
F. W. Hadden

Inventor
C. John Hagstrom
 By his Attorney
H. C. Karlson

C. J. HAGSTROM.
 DOOR OR WINDOW FASTENER.
 APPLICATION FILED MAY 4, 1912.

1,060,251.

Patented Apr. 29, 1913.

5 SHEETS-SHEET 5.

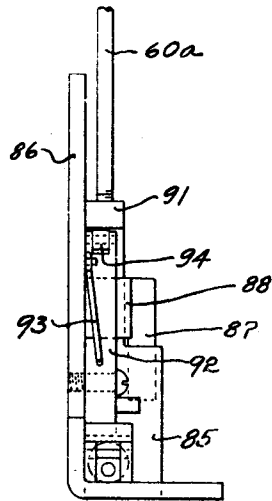

Fig. 25

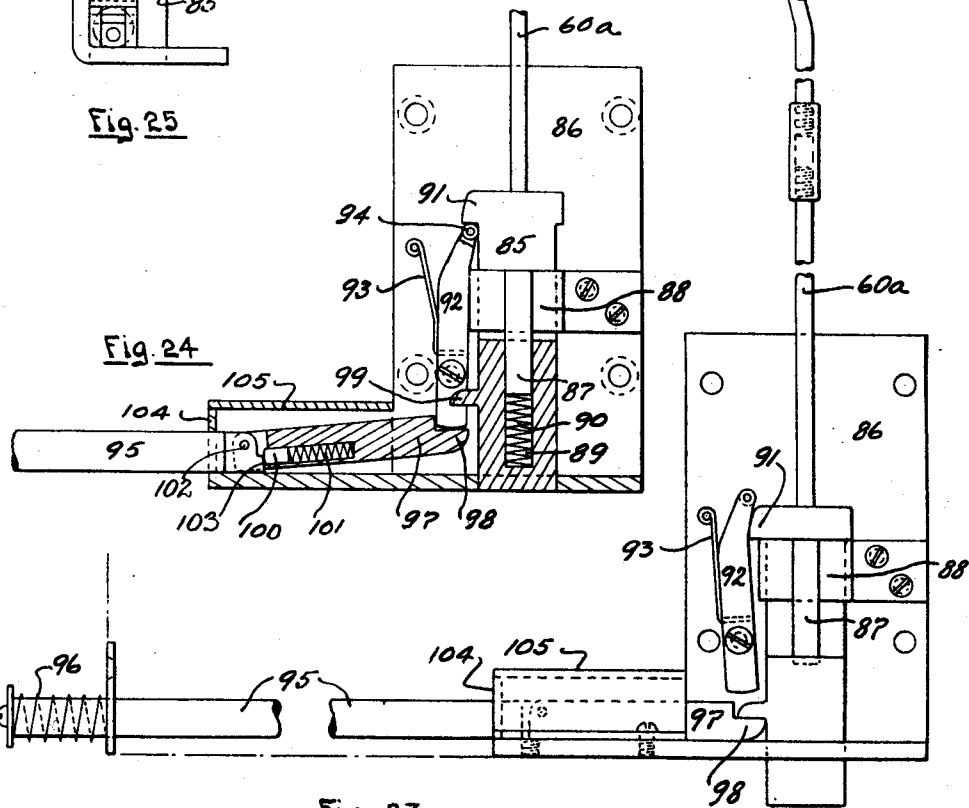
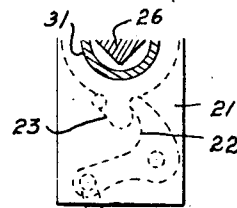

Fig. 24

Fig. 23

Witnesses:
R. Burley
J. W. Hadden

Inventor
C. John Hagstrom
 By his Attorney
H. C. Karlson

UNITED STATES PATENT OFFICE.

CARL JOHN HAGSTROM, OF GLEN COVE, NEW YORK.

DOOR OR WINDOW FASTENER.

1,060,251.

Specification of Letters Patent.

Patented Apr. 29, 1913.

Application filed May 4, 1912. Serial No. 695,240.

To all whom it may concern:

Be it known that I, CARL JOHN HAGSTROM, a citizen of Sweden, and resident of Glen Cove, Long Island, in the county of Nassau and State of New York, have invented certain new and useful Improvements in Door or Window Fasteners, of which the following is a specification.

This invention relates to locks adapted to fasten a door or window simultaneously both at top and bottom thereof.

One of the objects of the invention is the production of a lock which will automatically pick-up and hold together the fastening mechanism of the separately hinged parts of the so called Dutch-doors.

Another object is to produce a centrally operated top and bottom lock the constituent parts of which are invisibly contained within the stiles of casement windows or double doors.

A further object is a top and bottom lock for windows and doors so constructed that the lower latch is automatically prevented from dragging or scraping on the sill or floor when opened.

Still another object is to produce a lock for the purposes described which is simple, durable and amenable to manufacturing at low cost.

With these objects in view, the invention comprises the parts, combinations and improvements hereinafter described and shown in their preferred embodiments, and more particularly pointed out in the claims.

In the accompanying drawings hereto annexed: Figure 1 is a side view of the invention applied to a Dutch-door; Fig. 2 is a front view of Fig. 1; Fig. 3 is a side view of the invention applied to one of a pair of double doors; Fig. 4 is a front view of Fig. 3; Fig. 5 is a side view of the invention applied to a casement window; Fig. 6 is a front view of Fig. 5; in the above views the fragmentary outline of the door is shown by dash and dot lines. Fig. 7 is a rear view of the top catch; Fig. 8 is a side view of Fig. 7; Fig. 9 is a partial section on the line 9-9 of Fig. 7; Fig. 10 is a top plan view of Fig. 8; Fig. 11 is a bottom plan view of Fig. 8; Fig. 12 is a sectional side elevation of the lock and its actuating mechanism; Fig. 13 is a right hand side view of an in-

side carrier plate shown in Fig. 12; Fig. 14 is a left hand side view of the same carrier plate; Fig. 15 is a section on the line 15-15 of Fig. 14; Fig. 16 is a horizontal section on the line 16-16 of Fig. 12; Fig. 17 is an inside view of the right hand shield plate shown in Fig. 12; Fig. 18 is a rear view of the upper pick-up latch; Fig. 19 is a left hand side view of Fig. 18; Fig. 20 is a rear view of the lower pick-up latch; Fig. 21 is a left hand side view of Fig. 20; Fig. 22 is a section on the line 22-22 of the connected upper and lower latches illustrated in Figs. 18 and 20; Fig. 23 is a rear view of the foot bolt; Fig. 24 is a view similar to Fig. 23 with some of the elements shown in section and others in a changed position; and Fig. 25 is a left hand side view of Fig. 24 with some of the elements omitted.

The numeral 1 indicates an angular casing or bracket plate attached to the upper corner of a door or window and lying flush with the top and side surfaces thereof. On the underside of its top part the casing or support member 1 has guide ribs or strips 2 between which operates a pivoted catch 3. This catch operates in a slot in the top plate of the member 1, and the meeting surfaces of the catch member 1 at the ends of the catch, as indicated at 4 and 5, are curved on the arcs of circles so as to keep out water. At its upper corner adjacent the pivot the catch 3 is provided with a lip 6, which when the catch is projected upward in locking position as shown in Fig. 9 contacts with the upper edge of the vertical portion of the member 1, thereby both affording a stop and an additional guard against the entrance of water. The diagonally-opposite corner of the catch is provided with another lip 7, which contacts with the underside of the top plate of the member 1 to limit the movement of the catch. The catch is connected with a vertical slide 8 which moves in the guide 9, by means of a link 10, the upper portion of which is afforded clearance in a slotted recess 11 in the catch. The catch is provided with a depending arcuate guide rod 12, which passes through a guiding aperture in the laterally-bent portion of a bracket 14. Contact of the free end of this curved rod with the side plate of the member 1 limits

the downward or retracting movement of the catch. An expansion spring 13 is coiled about the rod 12 and confined between the catch and the bracket 14, so as to tend to urge the catch upward.

5 The upper end of a connecting rod 15 is secured to the slide 8, and its lower end is pivoted to a bell crank lever 20. The rounded nose 25 of the latter is adapted to contact with an operating projection 24 on a
10 rotatable operating member 23. The spring 13 operates to hold the said nose 25 in contact with the projection 24. The member 23 has a hub which is journaled in a bearing aperture in an interior carrying plate 21
15 fixed in a recess in the door or window. The member 23 has a reversely-disposed operating projection 24 which is contacted by the rounded nose 25 of a second bell crank lever 22,
20 which like the lever 20 is pivoted to the carrying plate 21. Another pull rod or link 60 is pivoted to the bell crank lever 22, and the spring 67 of the pick-up latch 61 (see Fig. 22) acting through this pull rod tends
25 to hold this bell crank lever in contact with the projection 24. The operating member 23 has a squared aperture slidably and removably receiving the square stem 26 of the operating knob 27 on the inside of the door
30 or window. After being turned by hand the operating member 23 is returned to normal position by means of a coiled spring 29, one end of which is fixed to the stem 26 and the other to a pin projecting from an exterior
35 plate 28, which covers the carrying plate 21 and the parts associated therewith in the recess in the door or window. A washer 30 with a notch in its periphery (see Fig. 17) limits the movement of the cam member 23 by cooperating with the pin 29^b
40 by which the spring 29 is anchored to the plate 28.

A knob 27^a is provided for operating the member 23 from the outside of the door, and
45 means are provided on the inside of the door whereby this knob may be disconnected from the said member. Furthermore, key-operated unlocking means are provided whereby the exterior knob 27^a may be re-
50 connected with the operating member 23. The hub of the said member is provided with teeth 31, constituting it a clutch member, with which cooperates another clutch member 32, having recessed teeth 33 and mounted
55 slidably on the stem 26^a of the knob 27^a. The clutch member 32 is urged into engagement with the clutch member constituting the hub of the operating member 23 by means of springs 34 coiled about rods 35 carried
60 by a plate 36, which engages the stem 26^a so as to turn therewith. The plate 36 finds an abutment against the cross-plate of a U-shaped housing 37, the ends of which are secured to the plate 21. The knob 27^a
65 may be returned to normal position by a

spring 29^a similar to the spring 29. A clutch-disengaging lever 38 is held at one end beneath a cam disk 39 and at the other end contacts with the face of the clutch member 32. This end of the lever may be notched
70 or bifurcated, as shown in Fig. 14, to straddle the hub of the operating member 23. The lever is offset intermediate its ends, as shown at 40, to afford a fulcrum, which bears against the bottom of a recess 41 in the plate
75 21. The lever is retained against sidewise displacement by ribs 42 on the plate 21. The cam disk 39 has a shank 43 rotatable in a bearing aperture in the plate 21, this shank being slotted at its end to receive a pin 44
80 carried by a socket 45 pinned to the stem 46 of a finger knob 47 on the inside of the door or window. By turning the cam disk 39 by the finger knob 47, the cam surface 39^a shown in Fig. 15 rides over the upper end of the lever
85 38, thereby moving the lower end of the lever outward so as to separate the clutch member 32 from the hub of the operating member 23, thus disconnecting the outside knob 27^a from said operating member 23.
90 The clutch lever 38 may be released from the outside of the door by means of a proper key inserted in a tumbler lock 50 of the Yale type, which like the knob 27^a is carried by an outside cover plate 28^a. This lock
95 50 has the conventional shank 51, which operates against shoulders 53 on the interior of the cam disk 39. These shoulders are spaced apart sufficiently, or in other words sufficient lost motion is provided, so that the
100 shank 51 may be returned to normal position to permit withdrawal of the key from the lock 50 without turning the cam disk 39, and also so that the knob 47 may turn the cam disk 39 without being blocked by the
105 said shank.

The operating member 23 and the cam disk 39 may be held to the carrying plate 21 by means of split clamps 55, 54, seated in grooves in their stem or hub portions and
110 bearing against opposite sides of the said plate. The socket 45 attached to the knob 47 is freely separable from the stem of the cam disk 39, and likewise the stem 26 of the knob 27 is separable from the operating member
115 23, so that the cover plate 28 may be readily removed with its parts, exposing to the plate 21 the parts carried thereby. In like manner the cover plate 28^a may be removed, carrying with it the lock 50 and the knob 27^a
120 with its stem 26^a, the latter sliding out of engagement with the clutch member 32 and the plate 36. Stop projections 25^a may be provided to be contacted by one of the projections 24 of the cam member 23, so as to
125 limit the movement thereof in opposite directions. Likewise the movement of the cam disk 39 in opposite directions may be limited by stops 39^b cooperating with a projection 39^c.
130

The lower end of the pull rod 60 is secured to the upper pick-up latch 61, which operates in the bottom of the upper half of the Dutch-door. The said latch 61 is slidably guided in an angular casing plate 62 secured to the door section and flush with the side and bottom surfaces thereof. The upper part of the said latch works in a keeper guide 64, and its lower part slides through an opening in the bottom part of the casing plate. A fixed depending plunger 65 is formed with the keeper 64 and enters a recess 66 in the pick-up latch 61; and a spring 67 confined in this recess between the bottom thereof and the lower end of the stationary plunger 65 urges the latch 61 downward, and also holds the bell crank lever 22 in contact with the corresponding projection on the cam member 23. The casing plate 62 is provided with a depending lip, which contacts with a casing structure 72 mounted in the upper part of the lower half of the door, for the purpose of limiting the relative swinging movement of the two door parts. The downward movement of the pick-up latch 61 may be limited by a stop 68 carried thereby and adapted to contact with the horizontal bottom portion of the casing plate 62. The upper pick-up latch 61 has a rounded nose portion 69 on its lower end, above which is a lateral recess or catch shoulder 70.

The lower pick-up latch 74 is slidable vertically in the top part of the stile of the lower half of the Dutch-door. It is mounted on a casing plate 72, between guides 73 thereon, and is held in position by a cover plate 75. Its lower end is loosely or pivotally connected to the pull rod section 60^a, and it is capable of limited lateral movement in its socket, being pressed away from the plate 72 by the flat spring 78 attached at one end to said plate and bearing at the other end against a plate 77 which lies flat against the back of the latch. A protuberance 79 on said plate rests against the upper end of the spring 78, which holds the plate from slipping down. The said plate affords a smooth bearing for the latch 74 to slide against, and it may also limit the upward movement of the latch by contacting at its lower end with the shoulder 80, as shown in Fig. 21. The downward movement of said latch is limited by a lug 81 thereon which contacts with the offset portion 82 of the cover plate 75. The latch 74 is pulled downward by the spring 90 (see Fig. 24), hereinafter referred to.

The upper end of the lower pick-up latch 74 is formed in complementary fashion to the upper pick-up latch 61, having a similar, but reversed, beveled nose 69^a, and a similar catch recess 70^a.

The upper part of the casing plate 72 is bent or disposed horizontally, then directed

downward, and then horizontally again to afford the riding lip 71 beveled at its end. In closing the two halves of the door together, the nose portion 69 of the upper pick-up latch 61 rides over this lip 71 and passes through the opening 76 in the angular plate 72, through which opening it moves down in front of the nose portion 69^a of the lower pick-up latch 74, being urged by the spring 67. In so doing it forces the lower pick-up latch 74 back against the tension of the spring 78, which forces the lower pick-up latch forward again, so that the nose or beak portion 69^a takes over the similar portion 69. In this way the upper latch 61 picks up the lower latch 74, not only locking the two halves of the door together but also connecting the pull rod 60^a, and consequently the bottom bolt 85, hereinafter described, to the operating member 23.

When the two halves of the Dutch door are brought together a lip 63 depending from the angular casing plate 62 contacts with the angular casing plate 72, thereby preventing relative movement of the two door parts in one direction. Relative movement or separation in the other direction is prevented by the entrance of the upper pick-up latch 61 into the recess in the lower door section, where it bears against the inner edge of the lip 71.

A knob 83^a extending outwardly from the link head 83 through a slot 72^a in the casing 72, is adapted for independent operation of the bottom bolt hereinafter referred to, when the upper and lower halves of the Dutch door are separate.

At the bottom of the door the bolt 85 secured to the lower end of the rod 60^a, slides on an angular casing plate 86, being guided in a keeper 88 thereon and also in an opening formed in the horizontal bottom part of the said casing plate. It is urged downward to enter the conventional floor socket (not shown) by a spring 90 housed in a pocket 89 in the bolt and bearing at opposite ends against the bolt and against a stationary plunger 87 formed with the keeper 88.

The bolt is held raised, so as not to drag on the floor, by a pawl 92, which is pivoted to the casing plate 86 and pressed by a spring 93 to engage beneath a lug or shoulder 91 on the bolt. The pawl may be provided with a roller 94. When the door is closed this pawl is automatically disengaged by means of a push rod 95 disposed within the bottom part of the door. One end of this push rod is projected from the hinge part of the door to contact with the door jamb, by means of a spring 96. When the door is closed the projecting portion of said rod 95 is forced into the door against the tension of said spring. To the other end of the rod is pivoted a dog 97, which con-

facts with the side of the lower portion of the pawl 92, so as to swing the upper part of the pawl in the opposite direction, thereby disengaging it from the shoulder 91 on the bolt. When the bolt 85 is pushed downward by its spring 90 it disengages the dog 97 from the pawl 92, so as to permit the latter to resume its normal position for reengagement with the shoulder 91 when the bolt is again lifted. To this end the bolt is provided with a lateral projection 99, which contacts with the dog 97, thereby depressing the same away from the pawl 92, to the position shown in Fig. 23. The downward movement of the bolt is limited by the dog 97 contacting with the horizontal bottom part of the plate 80.

The dog 97 is housed beneath a shield 105. Its forward end 98 may be notched or reduced to engage with the pawl 92 and the lug 99. It is tilted upward, so as to contact with the pawl 92, by means of a spring 101 housed in a barrel in the dog and forcing a plunger 100 against a surface 103 on the end of the rod 95, the point of contact being below the pivot 102. The movement of the rod 95 under the action of the spring 96 is limited by the rear end of the dog 97 contacting with the wall 104.

In operation, the top catch 3 normally projects up above the top of the door. When the door is closed it rides under the top of the door frame and springs upward into a suitable socket (not shown). It is pressed upward by the spring 13, which normally holds its bell-crank lever 20 in contact with the corresponding projection on the operating member 23. When the catch 3 yields downward in the act of closing the door the bell-crank 20 moves away from the member 23, without disturbing the latter or the bell-crank 22 and the parts below connected with this bell-crank. In like manner when the upper pick-up latch 61 rides upward on the lip 71, the bell-crank 22 is moved away from the corresponding projection 24 on the operating member 23 without disturbing the latter or the top catch 3. The bottom bolt 85 is always up when the lower part of the door is open, and down when this part of the door or both parts of the door are closed. The act of closing the lower part of the door automatically releases the pawl 92, permitting the spring 90 to shoot the bolt. The act of raising the bolt causes the pawl 92 to reengage with it, thereby holding it up. Turning of the operating knob 27, or of the other operating knob 27^a, on the outside, if this knob be connected with the mechanism, turns the member 23 through a partial revolution. This swings both of the bell-cranks 20 and 22, which pull down on the rod 15 and up on the rod 60. The pull on the rod 15

draws the catch 3 downward, thus releasing the door at the top. The upward pull on the rod 60 lifts the upper pick-up latch 61, and this draws up the lower pick-up latch 74. The pull is also transmitted to the rod 60^a, which raises the bottom bolt 85, thus releasing the door at the bottom. The pick-up latch 61 being raised out of the recess in the lower part of the door, the two halves of the door may be separated from each other. Upon release of the operating knob 27 or 27^a, as the case may be, the spring or springs 29, 29^a restore the knob and the member 23 to normal position, shown in Fig. 13, thereby permitting the spring 13 to raise the top catch 3 and the spring 67 to push the upper pick-up latch 61 downward. The catch 3 and the latch 61, are thus restored to position for reengagement with the parts with which they cooperate. It will be observed that the pick-up latches 61 and 74, serve as an automatic coupling for connecting the bottom bolt 85, carried by the lower part of the door to the operating member 23 and knobs, carried by the upper part of the door. The upper pick-up latch also serves to latch the two halves of the Dutch door together.

The operation of the cam disk 39 and the lever 38 by the knob 47 on the inside of the door to disconnect the knob 27^a on the outside of the door has been explained before, as also the use of the lock 50 to re-connect the said knob 27^a.

The construction of Figs. 3 and 4 is similar to that which has been described, except that the pick-up latches 61 and 74 are omitted, as being unnecessary for one of a pair of double doors. Instead of the rod 60, a rod 15^a is connected to the lower bell-crank 22 and extends downward and connects with the bottom bolt 85.

Figs. 5 and 6 represent the invention applied to a casement window. Here there are duplicate catches 3, 3 at the top and bottom, connected by rods 15 15^a to the bell-cranks 20, 22. The key-operated lock 50 and the finger knob 47, with the parts controlled thereby, have been dispensed with also.

The rods 15, 15^a, 60, 60^a operate in grooves or longitudinal recesses in the stiles of the doors or corresponding parts of the casement windows, and are covered by suitable strips. The catch 3, latches 61, 74 and bolt 85, with their associated parts, with the exception of the push-rod 95, are concealed in recesses in the stiles. The several pull rods 15, 15^a, 60 and 60^a are made in two pieces for convenience, and are connected by the couplings 16, 16^a.

Having described my invention what I desire to secure by Letters Patent and claim is:—

1. In a door or window fastening, the combination of a top catch pivoted in the

door or window and normally standing with its upper edge inclined, a vertical movable slide, a guide therefor, a link pivoted to said catch and slide, an operating stem in the door or window, an operating member inside the door or window connected to said stem, a bell-crank lever positioned to be rocked by said member, a pull rod connecting said slide and bell-crank lever, and a spring connected to and adapted to oppose the rotation of said stem at all positions thereof.

2. In a door or window fastening, the combination of a casing plate at the top of the door or window having a horizontal top part and a vertical side part, a catch pivoted near one end to said plate, the horizontal part of said plate having a slot through which said catch operates, said slot extending out so as to leave a gap in the top portion of said vertical wall, the ends of said catch and the corresponding edge of the slot being curved on an arc struck about the pivotal axis of the catch, and said catch being provided with two lips, one lip at its lower inside corner contacting with the horizontal casing part, and the other lip at its upper outside corner contacting with the vertical side part and covering said gap to prevent entrance of water.

3. In a door or window fastening, the combination of a casing member at the top of the door or window having a horizontal top wall and a vertical wall, spaced parallel guides on the under-side of said top wall, which has a slot, a catch pivoted between said guides and operating through said slot, a curved rod having one end secured to said catch, an angular bracket secured to said casing member and having an aperture in which said rod slides, the free end of said rod contacting with the vertical wall to limit the downward movement of the catch, and a spring coiled about said rod and confined between said catch and said bracket.

4. In a door or window fastening, the combination of an operating stem, an operating member turned thereby and having projections at top and bottom, upper and lower bell-cranks having their free end constantly contacting with said projections, a spring actuating said stem to hold said projections against the free ends of said bell-cranks, pull rods connected to the other ends of said bell-cranks and extending upward and downward, respectively, and locking members projecting through the top and bottom edges of the door connected with said pull rods.

5. In a door or window fastening, the combination of a pivoted operating member, knobs with stems on opposite sides of the door or window adapted to turn said member, a clutch member secured to said operating member, a second clutch member slid-

ably mounted on the stem of the outer knob and fixed therewith as to rotation, spring means for urging the slidable clutch member into engagement with the other, another knob on the inside of the door or window, and means whereby this knob disconnects the slidable clutch member.

6. In a door or window fastening, the combination of independent stems, a pivoted operating member carried by one of said stems, knobs on opposite sides of the door or window at the ends of said stems adapted to turn said member, a clutch member fixed to said operating member, a second clutch member slidable relatively to the first and connected to turn with the stem of the outer knob, spring means for urging said slidable clutch member into engagement with the other, another knob on the inside of the door or window, a cam connected to the last named knob, a lever fulcrumed intermediate its ends and adapted to be engaged at one end by said face cam and at the other end to press the slidable clutch member against the tension of said spring means.

7. In a door or window fastening, the combination of a carrying plate, an operating member mounted rotatably on said plate, knobs on opposite sides of the door or window adapted to turn said member, a clutch member fixed to said operating member, a second clutch member slidable relatively to the first and connected with the outer knob to turn therewith, spring means for connecting the clutch members, another inside knob, a face cam mounted rotatably on said carrying plate and connected with the last named knob, and a lever fulcrumed intermediate its ends on said plate, having one end received between said face cam and the carrying plate and the other end engaging said slidable clutch member.

8. In a door or window fastening, the combination of a carrying plate, an operating member mounted rotatably on said plate, knobs on opposite sides of the door or window adapted to turn said member, a clutch member fixed to said operating member, a second clutch member slidable relatively to the first and connected with the outer knob to turn therewith, spring means for connecting the clutch members, another inside knob, a face cam mounted rotatably on said carrying plate and connected with the last named knob, and a lever lying against said carrying plate, being offset intermediate its ends to fulcrum thereagainst, said plate having shoulders between which said lever is held against lateral displacement, one end of the lever being received between the face cam and said plate and the other end straddling one of said clutch members and bearing against the slidable clutch member.

9. In a door or window fastening, the combination of a carrying plate, an operat-

- ing member on one side of said plate having a hub rotatable in and passing through the plate, a spring-pressed axially movable clutch member at the opposite side of said plate adapted to connect with said operating member, knobs at opposite sides of the door, the inner knob being connected to said operating member and the outer knob to said clutch member, a cam on the opposite side of said carrying plate from said operating member, said cam having a shank rotatable in said plate and passing therethrough, another knob on the inside of the door connected to said shank, and a lever positioned to be operated by said cam and to disconnect said slidable clutch member.
10. In a door or window fastening, the combination of a carrying plate, an operating member mounted rotatably thereon and having a clutch member fixed therewith, knobs with stems on opposite sides of the door, the stem of the inner knob being connected to said operating member, a clutch member slidable and fixed against rotation on the stem of the outer knob, a plate on this stem having guide rods engaging the slidable clutch member and springs coiled about said rods, and a housing secured to said carrying plate and affording an abutment against which said rod-carrying plate is pressed by said springs.
11. In a door or window fastening, the combination of a pivoted operating member, knobs at opposite sides of the door adapted to turn said member, a clutch for connecting and disconnecting the outer knob, a pivoted part for operating said clutch, another knob on the inside of the door or window connected to said part, and a key operated lock on the outside having a turning member for operating said part, said lock member and clutch operating part having lost motion connections whereby said part may be turned by the knob without affecting the lock and whereby the lock member may be returned after actuation without returning said clutch operating part.
12. In a fastening for Dutch doors, the combination with operating mechanism carried by the upper part of the door, of a foot bolt carried by the lower part of the door, and connections between said operating mechanism and foot bolt including automatic coupling members carried by the two parts of the door.
13. In a fastening for Dutch doors, the combination with operating mechanism carried by the upper part of the door, and a bottom fastening carried by the lower part of the door, of pull connections between said operating mechanism and bottom fastening including vertically slidable coupling members carried, respectively, by the two parts of the door, and a socket in one part of the door having one of said coupling members therein, the other coupling member being spring projected and constituting a latch adapted to ride into said socket to connect the two parts of the door together, said coupling members having laterally projecting beaks for coupling together and one of the members being yieldable and spring-pressed laterally.
14. In a fastening for Dutch doors, the combination with operating mechanism carried by the upper part of the door, and a bottom fastening carried by the lower part of the door, of a pick-up latch slidable vertically in the bottom of the upper part of the door and connected with said operating mechanism, a spring forcing said latch downward, a socket in the top of the lower part of the door into which said latch rides when the door parts are brought in line, said latch having a beveled nose and a lateral recess, a pull rod in the lower part of the door connected to said bottom fastening, a vertically movable latching member located in said socket and formed to engage said pick-up latch, being connected to said pull rod so as to be capable of lateral yielding movement, and a spring pressing said latching member toward said pick-up latch.
15. In a fastening for Dutch doors, the combination with operating mechanism carried by the upper part of the door, and a bottom fastening carried by the lower part of the door, of a casing set in the lower part of the upper door member having a vertical wall, a horizontal wall and a lip depending from said horizontal wall and adapted to contact with the other door member to limit relative movement in one direction, a vertically slidable latch mounted on said casing and operating through an opening in said horizontal wall, a spring pressing said latch downward, a socket in the top part of the lower door member for the reception of said latch, a coupling member in the said lower door member adapted to engage automatically with said latch, and a pull rod connecting said coupling member and said bottom fastening.
16. In a fastening for Dutch doors, the combination of a casing set in the lower part of the upper door member, a vertically slidable latch having a recessed nose portion at its lower end guided in said casing, said latch being provided with a vertical spring barrel, a stationary plunger entering said barrel, a spring in the barrel acting against the lower end of said plunger to urge said latch downward, means attached to the upper end of the latch for pulling it upward against said spring, a casing in the upper part of the lower door and a latch in the latter named casing recessed oppositely to and adapted to receive the nose portion of the first named latch.
17. In a fastening for Dutch doors, the

combination of operating mechanism carried by the upper part of the door, a vertically movable latch carried by the upper part of the door and a spring urging the same downward, a casing set in the lower part of the door and having a vertical wall, a top wall and a laterally projecting inclined riding lip offset below said top wall and positioned to guide said latch, said casing having an opening, in its top through which said latch passes, a member in said casing adapted to couple automatically with said latch, and a fastening at the bottom of the lower door section connected with said member.

18. In a door fastening or the like, the combination of a foot bolt mounted in the bottom part of the door, a spring for shooting the same, a spring-actuated pawl adapted to automatically engage and hold said bolt retracted, means for automatically disengaging said pawl when the door is closed and other means carried by the latch for actuating said latter means whereby the pawl is set free to resume its normal position.

19. In a door fastening or the like, the combination of a casing set in the bottom of the door, a foot bolt having its upper and lower portions widened in opposite directions, a keeper with said casing intermediate the enlarged portions of said bolt limiting the travel thereof in both directions, the lower enlarged portion of the bolt being provided with a vertical barrel, a plunger on said keeper entering said barrel, a spring interposed between the bottom of the barrel and said plunger, and means attached to the upper enlarged portion of the bolt for pulling it up against said spring.

20. In a door fastening or the like, the combination of a foot bolt, a pawl adapted to automatically engage and hold said bolt retracted, and a thrust member having a flexible end projection carried by the door at right angles to said pawl, and in the same plane as the latter and the foot bolt, said thrust member being spring projected to contact with the hinge door jamb on closing of the door whereby to disengage said pawl said flexible projection yielding when the bolt is shot.

21. In a door fastening or the like, the combination of a foot bolt, a pawl adapted to automatically engage and hold said bolt retracted, a push rod carried horizontally lengthwise through the lower part of the door and spring projected to have its outer end contact with the hinge door jamb on closing of the door, a yieldable member carried by the inner end of said push rod to contact with said pawl to disengage the same, and means fixed to said bolt adapted to disengage said yieldable member from said pawl.

22. In a door fastening or the like, the combination of a foot bolt, a pawl adapted to automatically engage and hold said bolt retracted, a horizontal push rod carried by the door and spring projected to contact with the hinge door jamb, a dog pivoted to said rod, spring means for holding said dog in a position to contact with and disengage said pawl, and a projection on said bolt arranged to contact with and depress said dog out of engagement with said pawl.

23. In a door fastening or the like, the combination of a foot bolt, a pawl adapted to automatically engage and hold said bolt retracted, a horizontal push rod carried by the door and spring projected to contact with the hinge door jamb, a dog pivoted to said rod and having a spring barrel, a spring and a plunger therein, the latter contacting with the rod below the axis of said pivot, whereby the spring tilts the dog upward into position to contact with said pawl, and means whereby said bolt depresses said dog out of engagement with said pawl.

24. In a fastening for Dutch doors, the combination of a top fastening carried by the upper part of the upper door section, a bottom fastening carried by the lower part of the lower door section, intermediate fastening devices for holding the two door sections together, one of said fastening devices being carried by the lower part of the upper door section, and the other device being carried by the upper part of the lower door section, operating mechanism carried by the upper door section, connections in the upper door section between said operating mechanism and said top fastening and another connection between said operating mechanism and the upper intermediate fastening device, connections in the lower door section connecting said bottom fastening to the lower intermediate fastening device and means whereby the last named connections automatically couple with the connections in the upper door section.

25. In a fastening for Dutch doors, the combination of a top fastening carried by the upper part of the upper door section, a bottom fastening carried by the lower part of the lower door section, an intermediate fastening for connecting the two door sections together, operating mechanism carried by the upper door section, and connections in the two door sections connecting said top, bottom and intermediate fastenings with said operating mechanism.

26. In a fastening for Dutch doors, the combination of operating mechanism carried by the upper part of the door, a fastening carried by the upper part of the door for securing the lower part thereto, a bottom fastening carried by the lower part of the door, connections between said bottom fastening and said operating mechanism,

said connections being carried partly by the upper part of the door and partly by the lower part thereof and including the fastening for connecting the door sections together and means for operating said fastenings together or separately.

27. In a fastening for Dutch doors, the combination of a retaining bolt carried by one part of the door, coupling members between the door sections, an operating mech-

anism, and connections between said mechanism, said members, and said bolt.

Signed at the borough of Manhattan, in the county of New York and State of New York, this 26th day of April, A. D. 1912.

C. JOHN HAGSTROM.

Witnesses:

H. C. KARLSON,

W. H. GEE.

Copies of this patent may be obtained for five cents each, by addressing the "Commissioner of Patents, Washington, D. C."