

No. 780,196.

PATENTED JAN. 17, 1905.

J. KAYE.
ELEVATOR SAFETY DEVICE.

APPLICATION FILED FEB. 28, 1903.

3 SHEETS—SHEET 1.

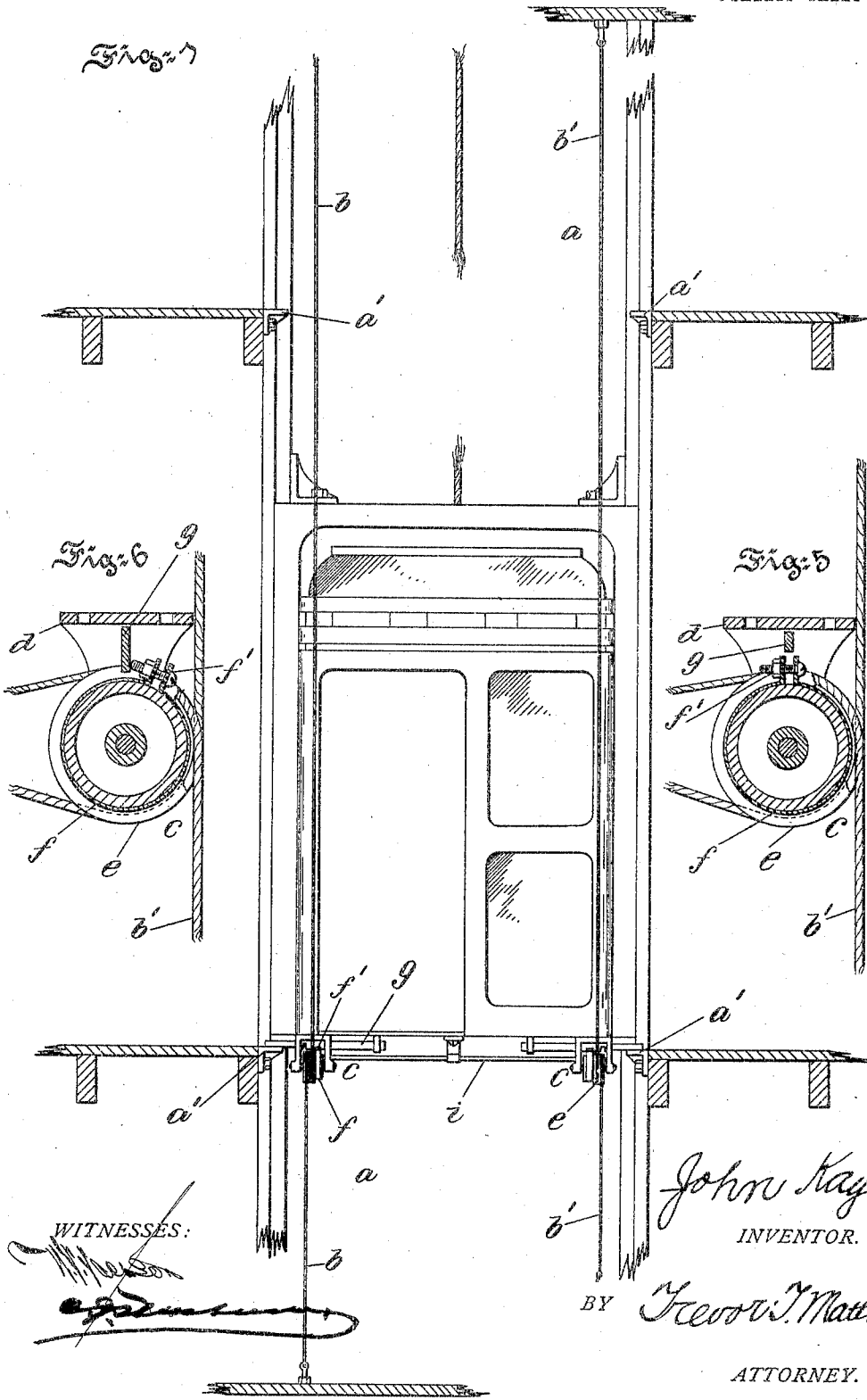

WITNESSES:

[Handwritten signatures]

John Kaye
INVENTOR.

BY *Frederic J. Matthews*
ATTORNEY.

J. KAYE.
ELEVATOR SAFETY DEVICE.
APPLICATION FILED FEB. 28, 1903.

3 SHEETS—SHEET 2.

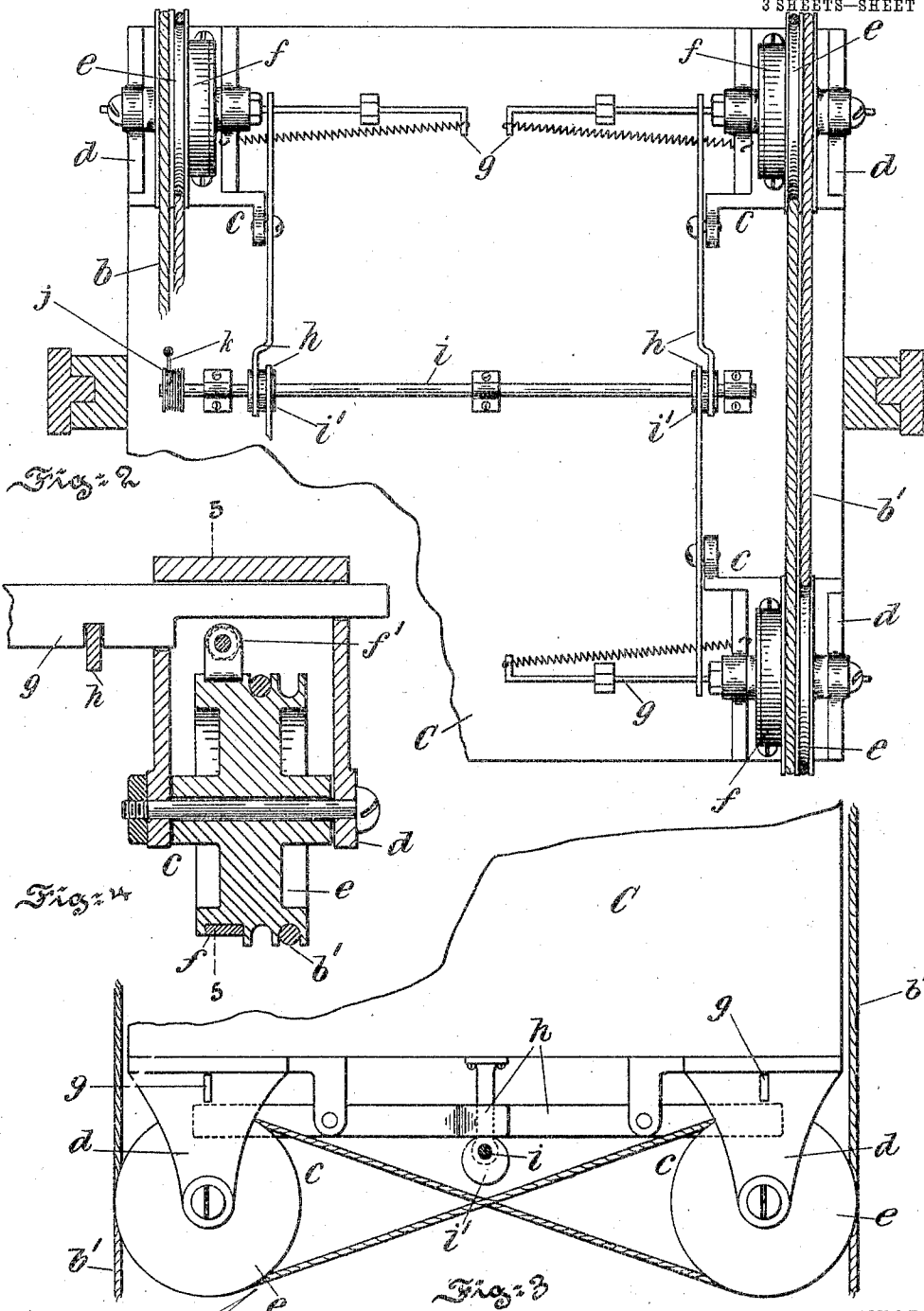

WITNESSES
Maey
Frank C. French

INVENTOR.
John Kaye
 BY
Trevor J. Matthews
 ATTORNEY.

No. 780,196.

PATENTED JAN. 17, 1905.

J. KAYE.
ELEVATOR SAFETY DEVICE.
APPLICATION FILED FEB. 28, 1903.

3 SHEETS—SHEET 3.

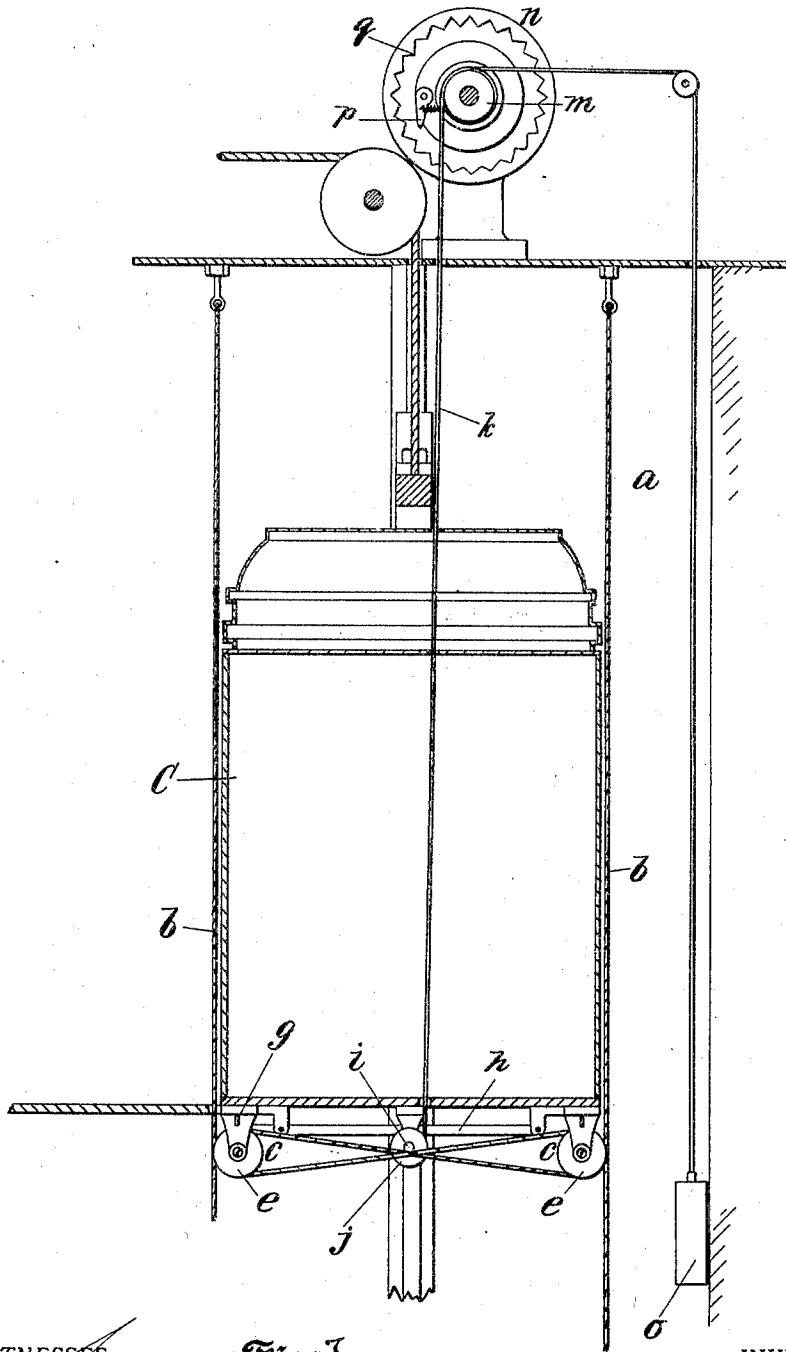

Fig. 1

WITNESSES:
[Signature]
Frank C. French

INVENTOR.
John Kaye
BY *Trevor J. Matthews*
ATTORNEY.

UNITED STATES PATENT OFFICE.

JOHN KAYE, OF PHILADELPHIA, PENNSYLVANIA.

ELEVATOR SAFETY DEVICE.

SPECIFICATION forming part of Letters Patent No. 780,196, dated January 17, 1905.

Application filed February 28, 1903. Serial No. 145,524.

To all whom it may concern:

Be it known that I, JOHN KAYE, a citizen of the United States, residing at Philadelphia, in the county of Philadelphia and State of Pennsylvania, have invented certain new and useful Improvements in Elevator Safety Devices, of which the following is a specification.

Accidents by reason of the breaking or derangement of the main hoisting-cable, for instance, frequently occur in places where elevators are used, resulting in loss of life and limb and otherwise causing much damage. It is one object of the present invention to overcome such defects and to provide such safety devices as will in the case of emergency automatically cause the elevator-car to slacken its speed and gradually come to rest at a predetermined spot.

Another object of the present invention is to provide light, durable, and comparatively inexpensive devices for this purpose.

A further object of the present invention is to adopt such devices to existing types of elevators without interfering with or altering the structure of the same.

The invention consists of the improvements hereinafter described and finally claimed.

The nature, characteristic features, and scope of the invention will be more fully understood from the following description, taken in connection with the accompanying drawings, forming part hereof, and in which—

Figure 1 is an elevational view, partly in section, of a hatchway and illustrating the position of a car after it has gradually come to rest subsequent to a broken main hoisting-cable. Fig. 2 is a view of the under side of the car, showing the application of the safety devices thereto and showing the cables *b* and *b'* crossing beneath the car from one side of the shaft to the other over the double-grooved sheaves. Fig. 3 is an elevational view of the lower portion of the same. Fig. 4 is a central sectional view of one of the safety devices. Fig. 5 is a view taken on the line 5 5 of Fig. 4. Fig. 6 is a similar view illustrating a position assumed by the devices after the operation of the governor in bringing the safety devices into action, and Fig. 7 is a sectional view taken at right angles to Fig. 1 and illus-

trating a governor and its connections with the elevator-car.

Referring to the drawings, *a* is the hatchway, provided at the different floors with stops or abutments *a'*, which, as shown, comprise angle-irons. Extending from the top to the bottom of the hatchway are wire cables *b* and *b'*, whose function will be described hereinafter.

c is the elevator-car. Located beneath the car, and preferably at each corner thereof, are safety devices. Obviously their number may be increased or diminished without departing from the spirit of the invention. These safety devices may be said to comprise castings *d*, to which are journaled double-grooved sheaves *e*. These sheaves are provided with what may be termed "adjustable" brakes *f*, which, as shown, comprise split rings or bands surrounding the rim of the sheaves and secured to place by means of threaded members and jam-nuts *f'*. The sheaves are alternately held and released by means of sliding bars *g* and their complemental pivotal catches *h*. These bars are notched and may act by reason of a counterweight or may be spring-controlled, as shown. The catches are operated by the shaft *i* and its cam member *j'* in a manner to be stated hereinafter. As shown in the drawings, at the left-hand end of the shaft *i* there is a drum *j*, having fastened thereto a cord *k*, which may be led up through the elevator-car, Fig. 7, and over the revoluble part *m* of the governor *n* and have secured at its free end a weight *o*. The governor may be of any of the well-known types, and the present style is merely illustrative of the invention. These safety devices, or rather the sheaves, are so arranged in respect to the cables *b* and *b'* that in the ordinary movement of the car they travel up and down these cables with comparatively little wear upon them. The cables are anchored at the bottom and are suspended from the top of the hatch by means of adjustable eyebolts to allow for obtaining proper tension. These cables are arranged with respect to the sheaves in the following manner: From the top of the hatch one cable extends downward and under one and over the other of the sheaves to the bottom of the

hatch, while the other of the cables extends from the bottom upward and over one and under the other of the sheaves to the top of the hatch. In other words, the cables cross each other beneath the car. This arrangement is repeated upon the opposite side of the hatch.

The operation of the above-described apparatus may be described as follows: In the normal course of the car up and down the hatch the safety devices would assume the position shown in Figs. 2, 3, 4, and 5—that is, the pivotal catch *h* would be in engagement with the notch in the sliding bars *g*—thus permitting the sheaves to rotate, by reason of the fact that the bars *g* are cut away sufficiently for this purpose. With reference now to Figs. 1 and 6, it will be assumed that the main hoisting-cable has broken or become deranged while the car was between the second and third floors, and thus causing it to increase its speed sufficiently to cause the spring-controlled pawl *p* of the governor *n* to fly outward and engage the rack *q*, whereupon the revoluble part *m* is stopped, thereby causing a sudden movement to be referred to the drum *j*, with the result that the shaft *i* and its cams *i'* are operated. Immediately the cams, through the instrumentality of the catches *h*, release the bars *g* and cause them to be thrown outwardly into alinement with the stops *a'*. By this movement the parts *f'* of the safety devices come in contact with the bars *g*, Fig. 6, thereby causing the brakes to act upon the hubs of the sheaves. Obviously this will cause the sheaves to assume a frictional relation with the cables *b* and *b'*, thus retarding the motion of the car and finally bringing the same to rest when the bars *g* reach the stops *a'*, Fig. 1. The sheaves being adjustable, they may be arranged to accommodate various degrees of weight to the following extent: Assuming that the elevator-car is used for carrying heavy loads, the bands *f* would be adjusted to positively stop the sheaves in case of accident, and thus depend upon the slippage of the cables *b b'* to gradually check the speed of the car. On the other hand, if the car carried only light loads the bands might be adjusted to slip with more or less friction upon the hubs of the sheaves.

It will be obvious to those skilled in the art to which the invention relates that modifications may be made in detail without departing from the spirit thereof. Hence I do not limit myself to the precise construction and ar-

range of parts herein shown and described; but,

Having thus described the nature and objects of the invention, what I claim as new, and desire to secure by Letters Patent, is—

1. In combination, an elevator-shaft, stops or abutments applied thereto, stationary cables extending from top to bottom of said shaft, a governor, a car, sheaves applied to the car and adapted to engage with the cables, brakes for the sheaves, sliding bars for the abutments, catches normally engaging said bars, cams and means between the governor and cams for operating said cams whereby when the car assumes an abnormal velocity the same is checked and gradually brought to rest, substantially as described.

2. Apparatus of the class designated comprising a pair of rotatable sheaves, brake members, sliding bars, catches for said bars, a governor, means between the governor and catches for releasing the bars and safety-cables arranged to frictionally engage the sheaves for retarding the motion of the car in case of emergency, substantially as described.

3. Apparatus of the character indicated, comprising a governor, a rotatable sheave having a rim, an adjustable brake for the rim, stationary cables for engaging the sheave, a sliding bar, a pivotal catch and means between the governor and the catch for releasing the bar, substantially as described.

4. Apparatus of the character indicated comprising a hatchway, stops secured to said hatchway, a governor, a car, rotatable sheaves upon the car, adjustable brakes for the sheaves, sliding bars, pivotal catches, and means operated by the governor for releasing and shifting the bars into engagement with the stops, substantially as described.

5. In combination an elevator-hatch having stops, a governor, a car, rotatable sheaves mounted thereon, stationary cables extending from top to bottom of the hatch and having engagement with the sheaves, brake members for the sheaves, sliding bars, pivotal catches and cams for said bars operated by the governor, substantially as described.

In testimony whereof I have hereunto set my hand this 26th day of February, 1903.

JOHN KAYE.

Witnesses:

W. J. JACKSON,
C. J. KETCHNER.