

May 21, 1940.

C. V. HALLENBECK
MEANS FOR ROAD SURFACING

2,201,534

Filed July 1, 1937

2 Sheets-Sheet 1

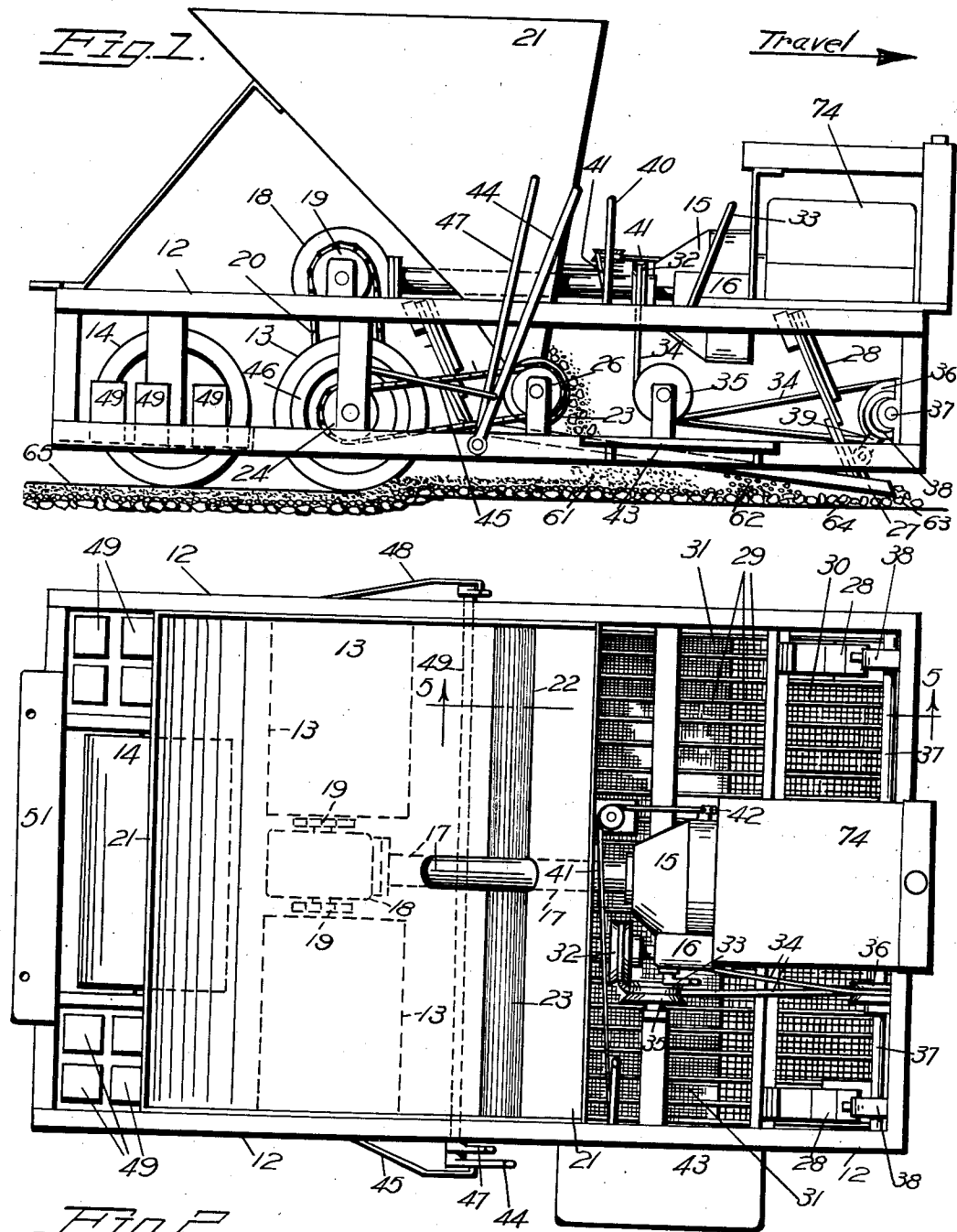

INVENTOR
CHARLES V. HALLENBECK

BY *[Signature]*
ATTORNEY.

May 21, 1940.

C. V. HALLENBECK

2,201,534

MEANS FOR ROAD SURFACING

Filed July 1, 1937

2 Sheets-Sheet 2

FIG. 3.

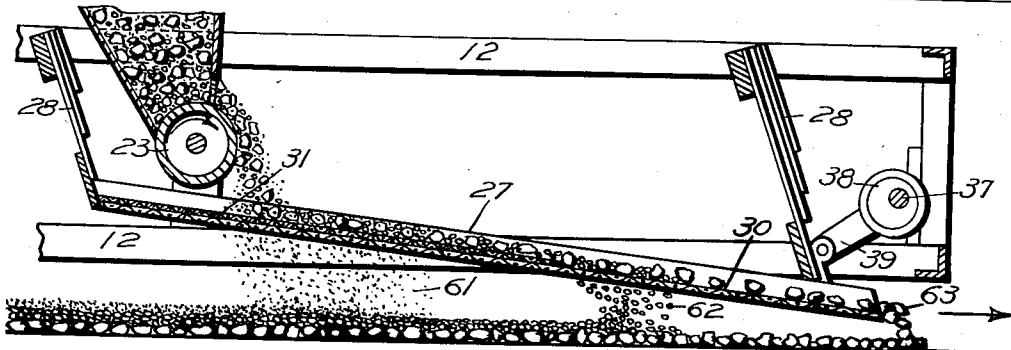
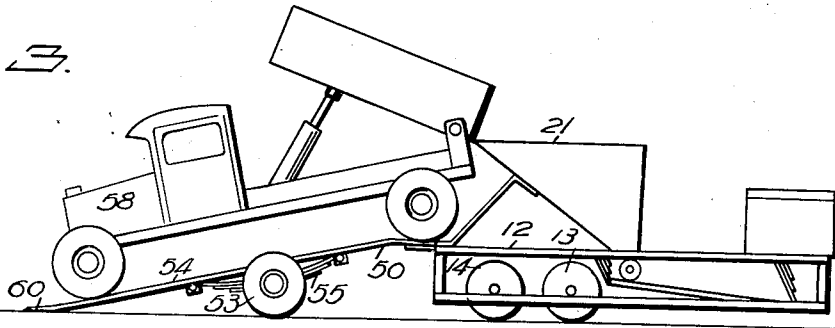

FIG. 5.

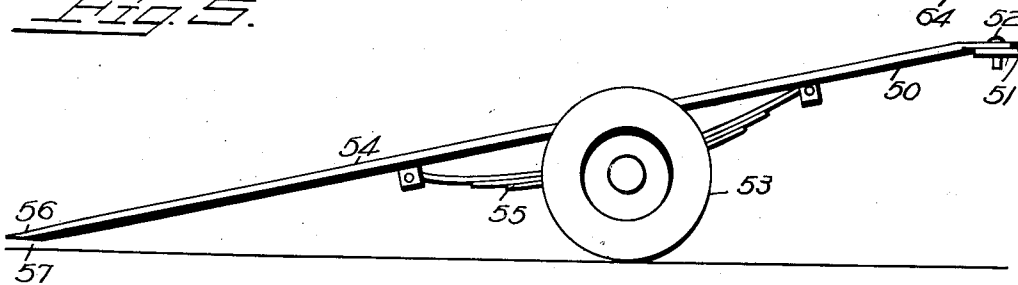

FIG. 4.

INVENTOR.
CHARLES V. HALLENBECK
BY *W. J. [Signature]*
ATTORNEY.

UNITED STATES PATENT OFFICE

2,201,534

MEANS FOR ROAD SURFACING

Charles V. Hallenbeck, Denver, Colo.

Application July 1, 1937, Serial No. 151,429

17 Claims. (Cl. 94-44)

This invention relates to improvements in means for and method of road-surfacing.

An object of the invention is to provide a machine which will automatically size-classify mixed road surfacing material such as gravel, rock chips or the like.

Another object is to provide a machine of this kind that will deposit the sized material in size-graded strata on and along the road bed to be surfaced, in the correct sequence of deposition.

A further object is the provision of a road-surfacing machine that will screen, spread and roll the material in one continuous operation.

A still further object is to provide such a machine that can readily be refilled with surfacing materials while maintaining it in its operating position.

Still another object is the provision of a road-surfacing machine that is self-propelled and which can be steered and otherwise fully controlled by one operator from a station thereon.

A still further object is to provide a machine for this purpose, that travels only on the surfaced road, it having no bearing on the unsurfaced road-bed.

Still another object of this invention is the teaching of a method of continuous screening, depositing and rolling, of road-surfacing material in size-classified strata and in correct sequence of deposition.

Other objects and advantages reside in details of design and construction which will be more fully disclosed in the following description and in the drawings wherein like parts are similarly designated and in which:

Figure 1 is a general side elevation of a road-surfacing machine built according to this invention;

Figure 2 is a plan view of the same;

Figure 3 is a side elevation of a similar machine, drawn on a smaller scale, and showing the means and method of supplying the machine with surfacing material;

Figure 4 is a side elevation, drawn on a larger scale, of a portable ramp built in accordance with this invention; and

Figure 5 is an enlarged fragmentary sectional view taken approximately on line 5-5 of Figure 2.

In the drawings, reference numeral 12 denotes a general supporting frame that is carried on propelling rollers 13 and idler roller 14 which overlaps the tracks of the propelling rollers in the direction of travel, as indicated by the arrow.

On the forward end of the frame is a power plant

74, preferably of the internal combustion automotive type, which includes a conventional clutch and transmission gearing in a housing 15 and a power take-off 16.

A tube 17 connects the transmission housing with a differential gear housing 18, and a propeller shaft, in the tube, transmits driving torque from the power plant to the differential gears, which in turn differentially drive sprockets 19, which differentially drive rollers 13 through the intermediary of drive chains 20.

An open top, V-shaped hopper 21 is mounted on the frame in a central location and has a relatively narrow transverse discharge slot 22 at its lower extremity. A feed roller 23 is driven in a forward direction of rotation by means of a sprocket 24 on one of the propeller rollers, and a chain 25 which cooperates with a driven sprocket 26 on the feed roller.

Immediately below the feed roller is a forwardly inclined screen assembly 27, which is resiliently suspended by means of leaf springs 28, the upper ends of which are carried by the frame structure. The screen assembly comprises a series of ribs 29 that serve to strengthen and support the assembly and to provide a series of channels therebetween that extend parallel to the direction of travel of the machine.

Beneath the ribs 29 is a coarse screen 30, on top of which is a finer screen 31 covering approximately the rear half of the coarse screen. It is not necessary to have the coarse screen extend back under the finer screen. A fine screen and a coarse screen may be placed edge to edge with the finer screen to the rear of the coarser one.

A V-belt pulley 32 is driven by the power take-off which is under control of an operating lever 33. A belt 34 is driven by the pulley 32 and passes around an idler 35, to drive a pulley 36 on a shaft 37, which carries a pair of eccentrics 38, having connecting rods 39, which are connected with the screen assembly to impart vibratory movement thereto.

A lever 40 is carried on the frame and is connected by means of a cable 41 to a clutch throw-out arm 42, so that an operator standing on an operator's platform 43 may disengage or engage the power-transmitting clutch as desired.

A braking lever 44 is connected by rod 45 to an internal expanding brake 46, which is operatively associated with the right-hand propelling roller 13. A second brake lever 47 is connected to a second and independent braking mechanism 48 by means of a cross-shaft 49, to apply braking

force when wanted, to the left-hand propelling roller 13.

A number of weights 49 are carried on platforms to the rear of the propelling rollers to counterbalance the weight of the machine that is forward of the axis of the propelling rollers, so that the entire structure ahead of this axis is suspended as a cantilever without touching the surface over which the machine is operated.

Figure 5 illustrates in detail the structure of the forwardly inclined vibratory screen and its actuating eccentric mechanism.

Figures 3 and 4 illustrates a portable lamp 50, which may be attached to a rear plate 51 carried on the frame 12, by means of pins 52. The ramp comprises an automotive-type running gear 53 and a track 54, which is suspended above the running gear by means of conventional leaf springs 55, so that the lower extremity 56 of the track is normally spaced away from the surface over which it is travelling, as shown at 57.

Operation

In use, an operator starts the power plant motor in a conventional manner and may thereafter control the machine from his station on platform 43. A truck driver backs a truck 58 up the ramp 50, as illustrated in Figure 3, to dump a load of mixed-size gravel or rock chips for road surfacing, into the hopper 21. The weight of the truck compresses the springs 55 so that the lower ends of the ramp track bear on the ground surface, as shown at 60. After the load of material has been deposited in the hopper 21, the driver of truck 58 may return to the source of supply for another load, while the operator of the surfacing machine proceeds to spread and to roll the material.

The clutch is engaged by means of lever 40 and cable 41, to transmit driving torque differentially to the two propelling rollers 13. The machine is guided by differential application of braking force to the rollers, by means of the levers 44 and 47 in the well-known manner. The forward motion of the rollers 13 transmits rotative driving force to the feed roller 23 at the lower end of the hopper, which movement will deliver a stream of mixed-size material onto the forwardly inclined screen assembly, which is being vibrated by the mechanism above described.

It will be clearly seen in Figures 1 and 5 that as the mixed-size material falls upon the screen assembly, it falls first upon the finer screen 31 so that the finest material, indicated at 61, will pass through at this location. As the material progresses forwardly and downwardly along the screen surface, it passes onto the coarser screen 30, where coarser material, indicated at 62, will pass through. The material 63 that is too large to pass through any screen mesh, will be discharged forwardly off of the forward end of the screen assembly, and it will be seen that, since the direction of travel is as indicated by the arrows in Figures 1 and 3, the coarsest material 63 will be deposited first in the forwardmost position on the road grade 64. The intermediate size material 62 will next be deposited in a stratum on top of the coarsest material, and the finest material 61 will be deposited on the uppermost surface. As the machine progresses forwardly, the rollers will smooth and compact the surfacing material as shown at 65 in Figure 1.

It will thus be seen that in a single progressive operation, this machine screens, classifies and deposits surfacing material in strata, with the

coarsest material in the lowermost position and the finest on the surface, which is an optimum method of road construction. The machine then rolls, smoothes and compacts the deposited material to a finished surface as it continues its progressive movement, and all of its functions are under the control of a single operator from his station 43.

In the meantime, one or more truck drivers may drive back and forth from the source of material supply to replenish the material in the hopper 21, so that the operation of the surfacing machine is only momentarily interrupted to receive a truck load of material at predetermined intervals.

It is understood that the ramp 50 will normally be attached to the spreader and trail along therewith, to receive the supply-trucks upon their arrival.

What I claim and desire to secure by Letters Patent is:

1. A road-surfacing machine of the class disclosed, comprising a carriage, a driving motor thereon, carriage roller wheels in driven relation to the motor, a forwardly inclined material size-classifying screen on the carriage, positioned to discharge the coarsest material farthest forward in the direction of travel of the machine, and mechanism for transmitting power from the motor to operate the screen.

2. A road-surfacing machine of the class disclosed, comprising a carriage, a hopper for mixed-sized surfacing material thereon, a driving motor thereon, carriage roller wheels in driven relation to the motor, a vibratory size-classifying screen mounted below the hopper, mechanism for transmitting power from the motor to vibrate the screen, and means comprising a feed roller, for delivering mixed material from the hopper onto the screen.

3. A road-surfacing machine of the class disclosed, comprising a supporting frame, a hopper for mixed-sized surfacing material thereon, a driving motor carried on the frame, frame-carrying roller wheels in driven relation to the motor, the frame extending forward of the roller wheels as a cantilever, there being sufficient weight to the rear of the axis of the roller wheels to overbalance the weight forward thereof, a forwardly inclined material size-classifying screen resiliently mounted forward of the roller wheels and below the hopper, mechanism for transmitting power from the motor to vibrate the screen, and means for delivering mixed material from the hopper onto the screen.

4. A road-surfacing machine of the class disclosed, comprising a carriage, a driving motor thereon, carriage roller wheels in driven relation to the motor, a forwardly inclined size-classifying screen resiliently mounted below the hopper, and mechanism comprising a power take-off at the motor, and an eccentric driven thereby connected with the screen, for transmitting power from the motor to vibrate the screen.

5. A road-surfacing machine of the class disclosed, comprising a carriage, a hopper for mixed-sized surfacing material thereon, a driving motor on the carriage, roller wheels in driven relation to the motor, a forwardly inclined material size-classifying vibratory screen mounted below the hopper to separate and deposit the coarsest material in a lowermost stratum on the road-bed, mechanism for transmitting power from the motor to vibrate the screen, and means

for delivering mixed material from the hopper onto the screen.

5 6. A road-surfacing machine of the class disclosed, comprising a carriage, a hopper for mixed-sized surfacing material thereon, a driving motor on the carriage, carriage roller wheels in driven relation to the motor, a forwardly inclined material size-classifying screen resiliently mounted below the hopper to deposit the finest material on the upper surface of the road, mechanism for transmitting power from the motor to vibrate the screen, and means for delivering mixed material from the hopper onto the screen.

10 7. A road-surfacing machine of the class disclosed, comprising a carriage, a hopper for mixed-size surfacing material thereon, a driving motor on the carriage, a size-classifying screen element on the carriage, positioned to deposit the material in at least three size-graded strata in correct sequence of deposition with the coarsest at the bottom and progressing to the finest on the top, mechanism for transmitting power from the motor to operate the screen, and means for delivering mixed material from the hopper onto the screen.

15 8. In a road-surfacing machine of the class disclosed, a surfacing-material size-classifying vibratory screen assembly, comprising a frame, a plurality of reinforcing channel-forming ribs extending thereacross in the direction of discharge, and a forwardly inclined screen positioned to discharge oversize ahead of undersize material.

20 9. A road-surfacing machine comprising a carriage, a driving motor therefor, rollers acting as wheels for the carriage, in driven relation to the motor, a portion of the carriage extending forward of the roller-wheels as a cantilever, and a size-classifying element on the cantilever-portion of the carriage, in a position to deposit classified material in the path of said rollers.

25 10. The combination with a road-building machine inclusive of a roller, of a size-classifying element for loose road-surfacing material positioned on the machine forward of said roller in the normal direction of travel and adapted to deposit classified material onto a road-bed in the path of said roller, with the coarser material deposited ahead of the finer.

30 11. The combination with a road-building machine inclusive of a roller, of a size-classifying vibratory screen for loose road-surfacing material positioned on the machine forward of said roller in the normal direction of travel and adapted to deposit screened material onto a road-bed in the path of said roller, with the coarser material deposited ahead of the finer.

35 12. The combination with a road-building machine inclusive of a roller, of a hopper on the machine for loose road-surfacing material, a size

classifying screen on the machine positioned forward of said roller in the normal direction of travel and adapted to deposit coarse screened material on a road-bed ahead of finer screened material, in the path of said roller, and means to deliver said mixed material from the hopper to the screen.

40 13. A road surfacing machine comprising a carriage movable along a roadbed, and a screen element mounted thereon in a position to deposit material onto the roadbed in size-classified strata, and including a plurality of screens of different mesh, with the screen of finest mesh in the most rearward position on the element with respect to the direction of travel of the carriage, and means associated with the screen element for delivering loose surfacing material onto the screen of finer mesh in a forwardly impelling movement.

45 14. A road surfacing machine comprising a carriage movable along a roadbed, and a screen element mounted thereon and inclining downwardly toward the forward end of the carriage, a plurality of screens of different mesh on the element with the coarsest size at the forward end of the element, and means on the carriage to deposit loose surfacing material onto the screen element at its rear end.

50 15. A road surfacing machine comprising a carriage, inclusive of a roller, movable along a roadbed, and mechanism on the carriage including a screen element mounted thereon in a position to deposit material onto the road bed in size-classified strata, a plurality of screens of different mesh on the element, with the screen of finest mesh in the most rearward position with respect to the direction of travel of the carriage and means associated with the screen element for delivering loose surfacing material onto the screen of finer mesh in a forwardly impelling movement.

55 16. A road surfacing machine comprising means for moving a quantity of mixed-size loose material along a road-bed, means for separating some of the material into size classes and depositing the differentially classified material in strata on said road-bed during said movement, and means comprising a roller associated with the movable means for compacting the stratified material.

17. A road surfacing machine comprising means for progressively moving a confined body of loose material along a road-bed, means for continuously depositing size-classified portions of said body differentially in strata on the road-bed with the finest material over the coarsest, and a driving element for the movable means positioned to compact the stratified material upon deposit on the road-bed.

CHARLES V. HALLENBECK.