

(12) STANDARD PATENT
(19) AUSTRALIAN PATENT OFFICE

(11) Application No. **AU 2002242577 B2**

(54) Title
Device for guiding a cerclage wire

(51)⁷ International Patent Classification(s)
A61B 017/82 A61B 017/58

(21) Application No: **2002242577** (22) Date of Filing: **2002.04.09**

(87) WIPO No: **WO03/084417**

(43) Publication Date: **2003.10.20**

(43) Publication Journal Date: **2003.11.27**

(44) Accepted Journal Date: **2005.10.27**

(71) Applicant(s)
Synthes AG Chur

(72) Inventor(s)
Rupp, Stephan

(74) Agent / Attorney
Phillips Ormonde & Fitzpatrick, Level 21 367 Collins Street, Melbourne, VIC, 3000

(56) Related Art
US 5810832
US 5851209
US 2002/004666
WO 2001/035843
US 5599322

(12) NACH DEM VERTRAG ÜBER DIE INTERNATIONALE ZUSAMMENARBEIT AUF DEM GEBIET DES PATENTWESENS (PCT) VERÖFFENTLICHTE INTERNATIONALE ANMELDUNG

(19) Weltorganisation für geistiges Eigentum
Internationales Büro



(43) Internationales Veröffentlichungsdatum
16. Oktober 2003 (16.10.2003)

PCT

(10) Internationale Veröffentlichungsnummer
WO 03/084417 A1

(51) Internationale Patentklassifikation⁷: A61B 17/82, 17/58

(21) Internationales Aktenzeichen: PCT/CH02/00199

(22) Internationales Anmeldedatum:
9. April 2002 (09.04.2002)

(25) Einreichungssprache: Deutsch

(26) Veröffentlichungssprache: Deutsch

(71) Anmelder (für alle Bestimmungsstaaten mit Ausnahme von CA, US): SYNTHES AG CHUR [CH/CH]; Grabenstrasse 15, CH-7002 Chur (CH).

(71) Anmelder (nur für CA): SYNTHES (U.S.A) [US/US]; 1690 Russell Road, P.O. Box 1766, Paoli, PA 19301-1222 (US).

(72) Erfinder; und

(75) Erfinder/Anmelder (nur für US): RUPP, Stephan [CH/CH]; Ortsstrasse 6, CH-7270 Davos (CH).

(74) Anwalt: LUSUARDI, Werther; Dr. Lusuardi AG, Kreuzbühlstrasse 8, CH-8008 Zürich (CH).

(81) Bestimmungsstaaten (national): AE, AG, AL, AM, AT, AU, AZ, BA, BB, BG, BR, BY, BZ, CA, CH, CN, CO, CR, CU, CZ, DE, DK, DM, DZ, EC, EE, ES, FI, GB, GD, GE, GH, GM, HR, HU, ID, IL, IN, IS, JP, KE, KG, KP, KR, KZ, LC, LK, LR, LS, LT, LU, LV, MA, MD, MG, MK, MN, MW, MX, MZ, NO, NZ, PL, PT, RO, RU, SD, SE, SG, SI, SK, SL, TJ, TM, TR, TT, TZ, UA, UG, US, UZ, VN, YU, ZA, ZW.

(84) Bestimmungsstaaten (regional): ARIPO-Patent (GH, GM, KE, LS, MW, MZ, SD, SL, SZ, TZ, UG, ZM, ZW), eurasisches Patent (AM, AZ, BY, KG, KZ, MD, RU, TJ, TM), europäisches Patent (AT, BE, CH, CY, DE, DK, ES, FI, FR, GB, GR, IE, IT, LU, MC, NL, PT, SE, TR), OAPI-Patent (BF, BJ, CF, CG, CI, CM, GA, GN, GQ, GW, ML, MR, NE, SN, TD, TG).

Veröffentlicht:

— mit internationalem Recherchenbericht

Zur Erklärung der Zweibuchstaben-Codes und der anderen Abkürzungen wird auf die Erklärungen ("Guidance Notes on Codes and Abbreviations") am Anfang jeder regulären Ausgabe der PCT-Gazette verwiesen.

(54) Title: DEVICE FOR GUIDING A CERCLAGE WIRE

(54) Bezeichnung: VORRICHTUNG ZUR FÜHRUNG EINES CERCLAGEDRAHTES

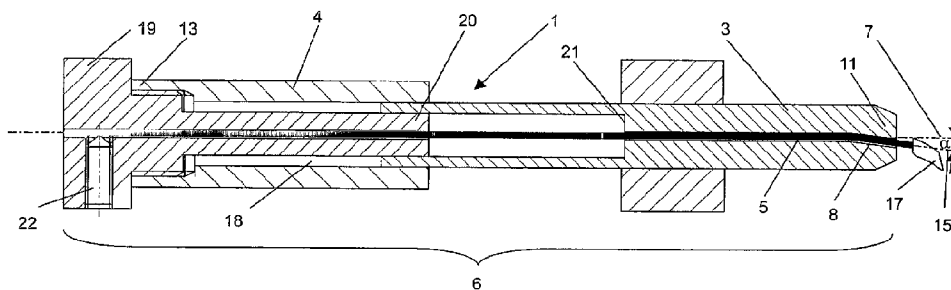

WO 03/084417 A1

(57) Abstract: The invention relates to a device for guiding a cerclage wire around a bone, comprising: A) a longitudinal shaft (6) that can be placed against a bone (2), has a central axis (7), a front end (11) and a central boring (8), which is open at the front end (11) of the shaft (6) while having a central axis (15), and; B) an axially displaceable longitudinal flexible guiding wire (5), which can be extended out of the central boring (8) at the front end (11) of the shaft (6), whereby; C) the central boring (8) at the front end (11) of the shaft (6) has a central axis (15) that is at an angle to the central axis (7) of the shaft (6) whereby causing the guiding wire (5) at the front end (11) of the shaft (6) to extend at an angle to the central axis (7) of the shaft (6).

(57) Zusammenfassung: Vorrichtung zur Führung einer Cerclage um einen Knochen herum umfassend A) einen an einen Knochen (2) anlegbaren, longitudinalen Schaft (6) mit einer Zentralachse (7), einem vorderen Ende (11), und einer Zentralbohrung (8), die am vorderen Ende (11) des Schaftes (6) offen ist, wobei die Zentralbohrung (8) am vorderen Ende (11) des Schaftes (6) eine gegenüber der Zentralachse (7) des Schaftes (6) abgewinkelte Zentralachse (15) aufweist, so dass der Führungsdraht (5) am vorderen Ende (11) des Schaftes (6) gegenüber der Zentralachse (7) des Schaftes (6) abgewinkelt wird.

DEVICE FOR GUIDING A CERCLAGE WIRE

5 The invention relates to a device for guiding a cerclage about a bone.

 The discussion below of the background to the invention is included to explain the context of the invention. This is not to be taken as an admission that any of the material referred to was published, known or part of the common general knowledge
10 in the art as at the priority date established by the present application.

 For osteosynthetic interventions, the guiding of a cerclage wire or cable about long tubular bones or at the pelvis is associated with a large detachment of soft parts around the bone. In order to avoid large openings, the cerclage wire must be
15 guided with a special guiding device underneath the tissue around the bone.

 A device for guiding a catheter to a particular position, for example, within a blood vessel, by means of a guide wire is disclosed in EP 0 141 006 of SAKAMOTO. This device comprises a guide wire for a catheter, which comprises, on
20 the one hand, a distal end section, which is sufficiently flexible so that it can be introduced, for example, into a complex vascular system, and, on the other, a trunk section, which is sufficiently stable to prevent deformation. With regard to guiding the end section about a bone, it is a disadvantage of this device that the flexible end section is extended linearly coaxially from the catheter, so that a curvature cannot be impressed
25 upon the flexible end section, which is to be introduced, before this end section is guided around a bone.

 Therefore, it would be desirable to create a device for implanting cerclages, by means of which a guide wire can be extended from a stiffer shaft segment
30 telescopically and pre-bent to approximate the curvature of the bone surface, so that the stiffer shaft segment can be placed against the bone and the tip of the guide wire can slip between the bone and the soft parts around the bone.

According to the present invention, there is provided a device for guiding a cerclage about a bone, including

- 5 A) a longitudinal shaft, which can be placed in contact with a bone, with a central axis, a front end and a central borehole, which is open at the front end of the shaft, with a central axis and
- B) an axially displaceable, longitudinally bendable guide wire, which can be extended at the front end of the shaft from the central borehole wherein
- 10 C) the central borehole, at the front end of the shaft, has a central axis, which is angled with respect to the central axis of the shaft, so that the guide wire at the front end of the shaft is angled with respect to the central axis of the shaft.

15 Preferably, the central borehole can be shaped so that its central axis is curved or bent at an angle with respect to the central axis of the shaft. This configuration of the central borehole can allow the guide wire to be extended from the shaft deformed and pre-bent to correspond approximately to the periphery of the bone.

20 Advantages that can be achieved by the invention include one or more of the following:

- only a small incision is required;
- detachment of the soft parts over a large area is not necessary; and
- 25 • only a slight interference with the blood supply is caused.

In the preferred embodiment of the inventive device, the angle α between the central axis of the shaft and the central axis of the central borehole at the front end of the shaft is preferably between 1° and 90° . The angle selected determines the axial deformation of the guide wire as well as the exit angle at the front end of the shaft with respect to the central axis of the shaft. A better guidance of the guide wire about the bone can be achieved by pre-bending the guide wire in the device.

In a different embodiment of the inventive device, the guide wire is produced from a highly elastic material (such as Nitinol or spring steel).

In a different embodiment of the inventive device, the guide wire is produced from a plastically deformable material, as a result of which a permanent pre-bending can be impressed on the guide wire at the outlet on the shaft.

In yet another embodiment of the inventive device, the latter comprises a headpiece at the front of the guide wire. This headpiece has a borehole with, for example, two constrictions. The different diameters of the borehole and the constrictions permit cerclage wires or cables of different thicknesses to be pressed into the borehole or into one of the constrictions. Furthermore, it can become possible to introduce a cerclage wire or cable into the borehole from a lateral external wall up to the borehole or up to a transverse borehole penetrating into the constrictions and to pass it out of the headpiece once again through the transverse borehole. By these means, it can be achieved that the cerclage wire does not have to be pressed into the borehole or one of the constrictions and, instead, can be fastened to the headpiece by means of a loop.

Various driving mechanisms are possible for axially displacing the guide wire relative to the shaft:

- the shaft comprises a front shaft segment and a rear shaft segment, it being possible to telescope the two shaft segments parallel to the central axis of the shaft and relative to one another, so that the guide wire can be extended and retracted by shifting the two shaft segments relative to one another;
- the shaft comprises a sliding element, which can be shifted parallel to its central axis and is connected with the guide wire, so that the guide wire can be extended and retracted by axially displacing the sliding element or

- the shaft comprises a rack mechanism, which can be moved, for example, by means of a nut in the shaft parallel to the central axis. The guide wire, which is firmly connected with the rack, can be extended or retracted from the shaft by axially moving the rack relative to the shaft.

5
10 In a different embodiment of the inventive device, the shaft is angled at its front end, a construction, angled in curved or linear form, also being possible here. The shaft is bent at an angle so that it can be placed better with its front end against the periphery of the bone.

15 The guide wire may be cylindrical or prismatic. In order to achieve a high stiffness to counter twisting, the guide wire may have, for example, a rectangular cross section.

20 In a further embodiment of the inventive device, the guide wire is drilled coaxially and constructed hollow cylindrically or hollow prismatically, so that, for example, a cerclage wire can be accommodated in the cavity of the guide wire and guided, together with the guide wire, around the bone.

25 The invention and further developments of the invention are explained in even greater detail by means of the partially diagrammatic representations of several examples. In the representations,

FIG. 1 shows a view of an embodiment of the inventive device with the guide wire retracted;

FIG. 2 shows the embodiment of the inventive device of FIG. 1 with the guide wire extended completely;

FIG. 3 shows a view of a further embodiment of the inventive device with the guide wire partially extended;

FIG. 4 shows the embodiment of the inventive device of FIG 3 with the guide wire extended completely;

FIGS. 5a to 5c show a longitudinal section through a head piece of an embodiment of the inventive device;

FIG. 6 shows a view of a further embodiment of the inventive device with a rack mechanism and

FIG. 7 shows a view of a further embodiment of the inventive device.

In FIG. 1, an embodiment of the inventive device 1 is shown with a shaft 6, having a front shaft segment 3 and a rear shaft segment 4, and a guide wire 5, which can be extended at the front end 11 of the shaft 6. The two shaft segments 3; 4 are configured so that they can be telescoped parallel to the central axis 7. In this embodiment, the front shaft segment 3 can be taken up axially displaceably in the borehole 18 in the rear shaft segment 4, which is coaxial with the central axis 7. At the rear end 13 of the shaft 6, a connecting piece 19 is screwed in, which has a front end 20 protruding coaxially into the borehole 18 in the rear shaft segment 4. When the guide wire 5 is extended completely, the front end 20 of the connecting piece 19 comes up against the shoulder 21 in the central borehole 8 of the front shaft segment 3 (FIG. 2), so that an axial stop for the displaceability of the two shaft segments 3; 4 relative to one another is formed by these means. At the front end 11 of the shaft 6, the central borehole 8 is angled so that the central axis 15 of the central borehole 8

forms an angle α with the central axis 7 of the shaft 6 formed by the 2 shaft segments 3; 4. Furthermore, the guide wire 5 is fixed axially in the connecting piece 19 by a setscrew 22. A headpiece 17, in which a cerclage wire (FIGs. 5a – 5c) can be accommodated, is mounted at the front at the guide wire 5.

FIG. 2 shows the device 1 with the guide wire 5 extended completely. For guiding the guide wire 5 around a bone 2, the front end 11 of the shaft 6 is brought into contact with the bone surface and held in this position. If the rear shaft segment 4 is shifted axially relative to the front shaft segment 3, the guide wire 5 is shifted axially along with it and extended at the front end 11 of the shaft 6 at an angle to the central axis 7 of the shaft 6.

FIGs. 3 and 4 show an embodiment of the inventive device, in which the central borehole 8 has a curved central axis 15 at the front end 11 of the shaft 6. At the outlet from the shaft 6, the central axis 15 of the central borehole 8 and the central axis 7 of the shaft 6 once again enclose an angle α . The guide wire 5 is displaced axially by a sliding element 9, which is disposed in the shaft 6 so that it can be displaced axially. The sliding element 9 may be disposed, for example, in a groove (not shown) in the shaft 6. In FIG. 4, the sliding element 9 is in its foremost position, so that the guiding wire 5 can be passed completely around a bone 2.

The device 1 can be inserted through the main incision or through a small incision, which is made especially for this step. The front segment 3 of the shaft 6 is placed against the bone surface and held. Subsequently, the guide wire 5 is extended telescopically by means of a sliding element 9, which can be shifted at the rear shaft segment 4 parallel to the central axis 7 of the shaft 6. At the same time, the free end of the guide wire 5 automatically follows its way around the bone 2. The free end of the guide wire 5 slides between the bone 2 and the soft parts (not shown) and around the bone 2. When the free end of the guide wire 5 has been passed around the bone 2, the cerclage wire (not shown) or the cerclage cable is fastened to the head

piece 17 of the guide wire 5 and, by retracting the guide wire 5 by means of the sliding element 9, passed around the bone 2.

An embodiment of the headpiece 17 is shown in FIGs. 5a to 5c. This headpiece 17 is fastened to the front of the guide wire 5 and is passed around a bone 2 (FIG. 2) together with the guide wire 5. The headpiece 17 has a borehole 23, which includes a first and a second constriction 24; 26 in the head piece 17. The dimensions of the constrictions 24; 26 are such, that cerclage wires 25 with different diameters can be pressed, in each case, into one of the constrictions 24; 26. Furthermore, the borehole 23 includes a transverse borehole 27, which passes through the headpiece 17 transversely to the axis of the borehole 23 and from the borehole 23 to the exterior surface of the headpiece 17. With that, a cerclage wire 25 can be introduced into the borehole 23 and passed through the transverse borehole 27, so that a loop can be formed in the cerclage wire 25. The cerclage wire 25 is then fixed by means of the loop to the headpiece 17.

The embodiment of the inventive device 1, shown in FIG. 6, differs from those shown in FIGs. 1 to 4 only in that the guide wire 5 can be moved in the shaft 6 by a rack mechanism 16 parallel to the central axis 7 of the shaft 6 and can be extended and retracted at the front end 11 of the shaft 6 analogously to the embodiments of FIGs. 1 to 4. The rack mechanism 16 comprises essentially a rack 29, which can be displaced in the central borehole 8 parallel to the central axis 7 of the shaft 6 and can be moved by a nut 28, which is connected with the shaft 6 axially fixed and rotatable about the central axis 7. The rack 29 can be moved axially by the internal thread of the nut 28 engaging the teeth of the rack.

FIG. 7 shows an embodiment of the inventive device 1, which differs from the embodiments of FIGs. 1 to 4 and 6 only in that the shaft 6 is angled or bent at its front end 11, so that the central axis 7b at the front end 11 of the shaft 6 encloses an angle β with the central axis 7a of the remaining length of the shaft 6.

Throughout the description and claims of the specification, the word “comprise” and variations of the word, such as “comprising” and “comprises”, is not intended to exclude other additives, components, integers or steps.

- 5 The invention described herein is susceptible to variations, modifications and/or additions other than those specifically described and it is to be understood that the invention includes all such variations, modifications and/or additions which fall within the spirit and scope of the above description.

THE CLAIMS DEFINING THE INVENTION ARE AS FOLLOWS:

1. A device for guiding a cerclage about a bone, including
 - A) a longitudinal shaft, which can be placed in contact with a bone, with a central axis, a front end and a central borehole, which is open at the front end of the shaft, with
5 a central axis and
 - B) an axially displaceable, longitudinally bendable guide wire, which can be extended at the front end of the shaft from the central borehole wherein
 - 10 C) the central borehole, at the front end of the shaft, has a central axis, which is angled with respect to the central axis of the shaft, so that the guide wire at the front end of the shaft is angled with respect to the central axis of the shaft.

2. A device according to claim 1, wherein at the front end of the shaft, the central
15 axis of the central borehole encloses an angle α of between 1° and 90° with the central axis of the shaft.

3. A device according to claim 1 or 2, wherein the guide wire is deformable elastically.
20

4. A device according to any one of claims 1 to 3, wherein the device includes, at a front end of the guide wire, a head piece, which has a borehole with several constrictions, the diameters of the head piece borehole and of the constrictions being such that different cerclage wires or cables can be pressed into the head piece borehole
25 or into one of the constrictions.

5. A device according to claim 4, wherein, in the head piece, a transverse borehole is additionally provided, which passes through the head piece between the head piece borehole and an exterior wall of the head piece, so that a cerclage wire or cable can be
30 passed in a loop through the head piece borehole and the transverse borehole.

6. A device according to any one of claims 1 to 5, wherein the guide wire is drilled coaxially.

7. A device according to any one of claims 1 to 6, wherein the shaft includes a front shaft segment and a rear shaft segment and that the front and rear shaft segments can be telescoped parallel to the central axis of the shaft and relative to one another, so that the guide wire can be extended at the front end of the shaft by retracting one of the front and rear shaft segments into the other of the front and rear shaft segments.

8. A device according to any one of claims 1 to 6, wherein the guide wire can be extended from the front end of the shaft by means of a sliding element, which can be shifted coaxially with the central axis of the shaft.

9. A device according to any one of claims 1 to 6, wherein the guide wire may be extended at the front end of the shaft by means of a rack mechanism.

10. A device according to any one of claims 1 to 9, wherein the shaft is angled or bent at its front end, so that the central axis of the shaft, at the front end of the shaft, encloses an angle β with the central axis of the shaft through the remaining length of the shaft.

11. A device according to claim 10, wherein the angle β is between 1° and 90° .

12. A device according to any one of the embodiments substantially as herein described and illustrated.

DATED : 25 October, 2004

PHILLIPS ORMONDE & FITZPATRICK

Attorneys For:

SYNTHES AG CHUR

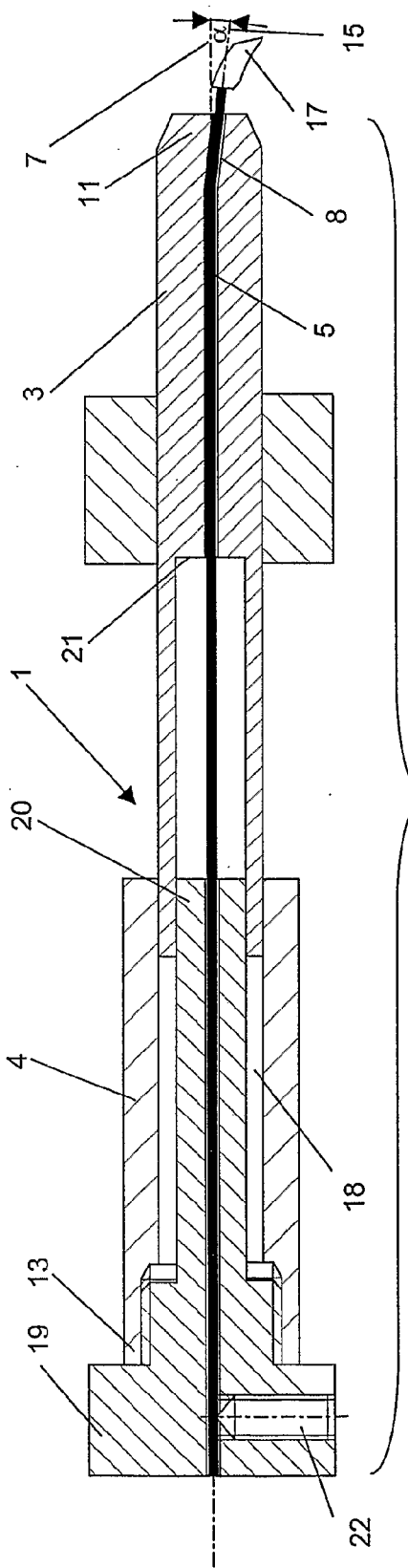

Fig. 1

1/5

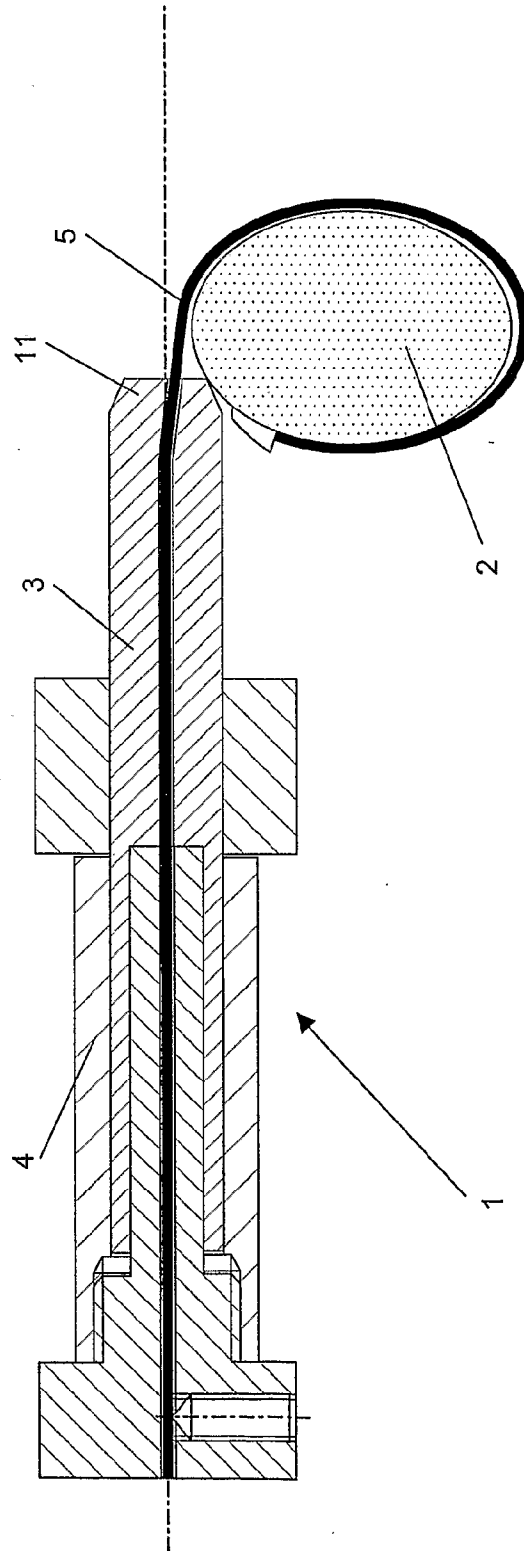

Fig. 2

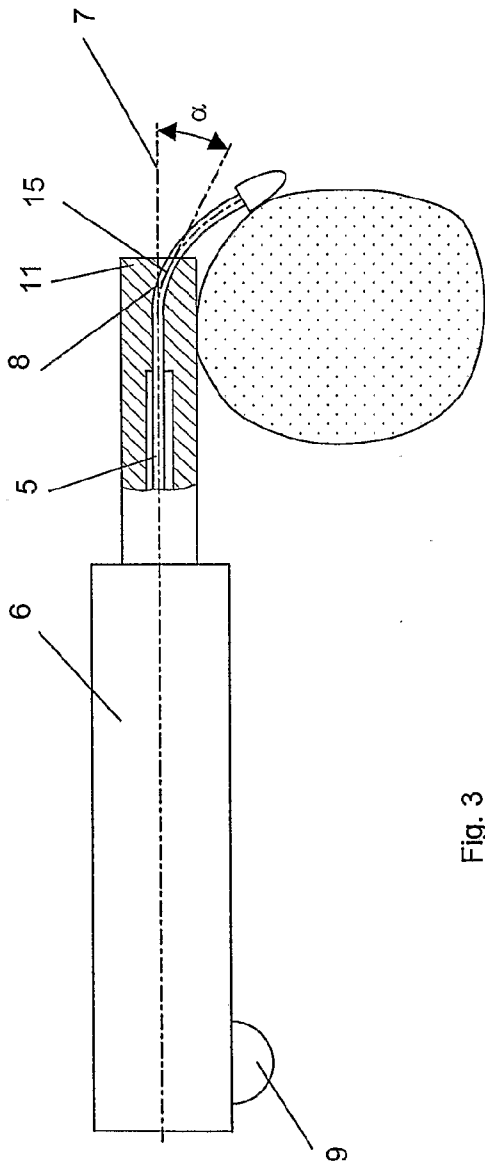

Fig. 3

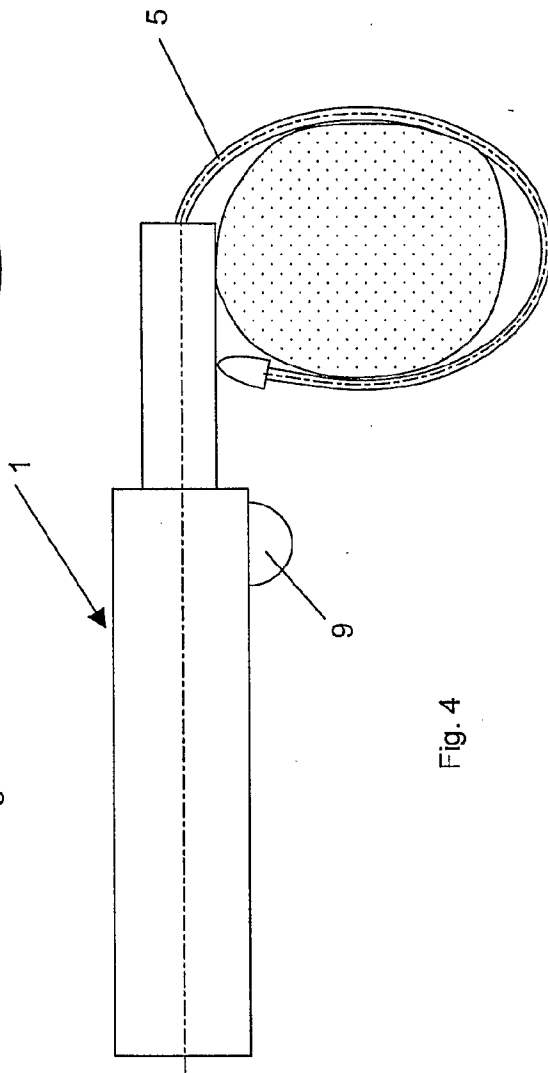

Fig. 4

3 / 5

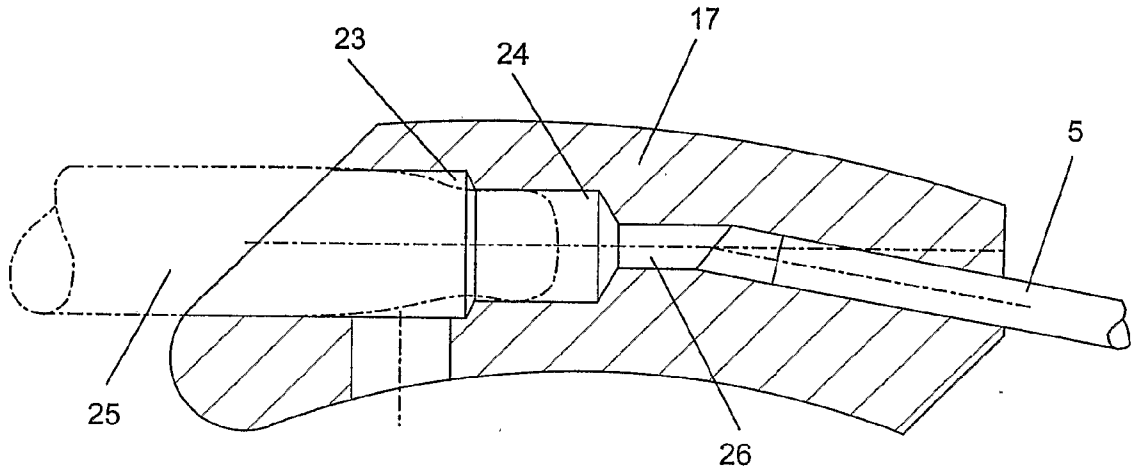

Fig. 5a

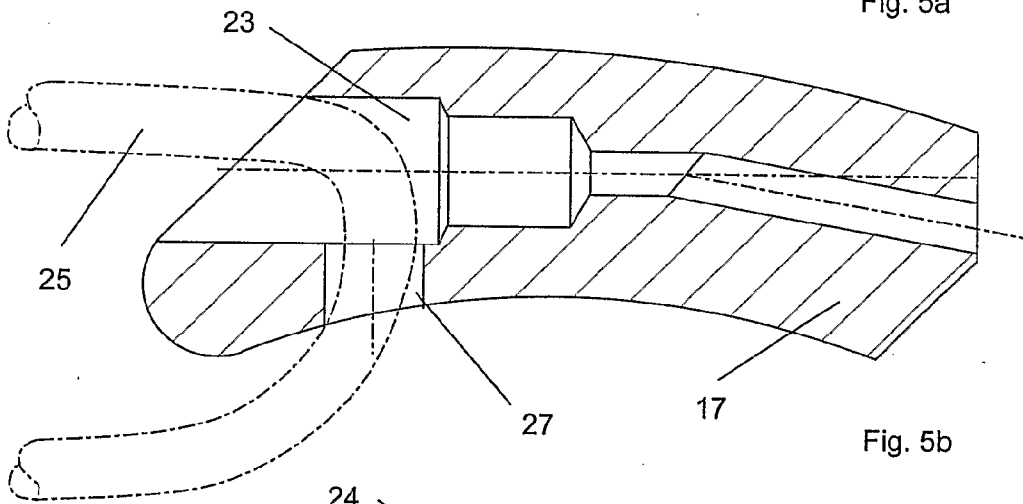

Fig. 5b

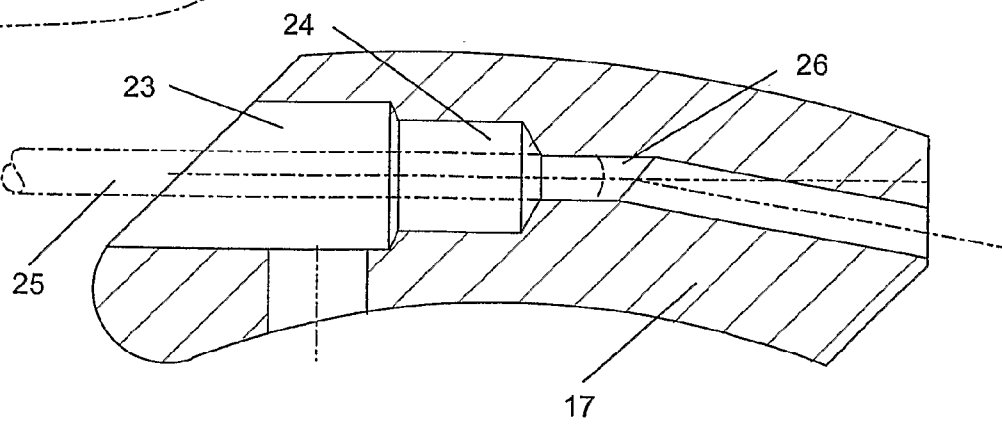

Fig. 5c

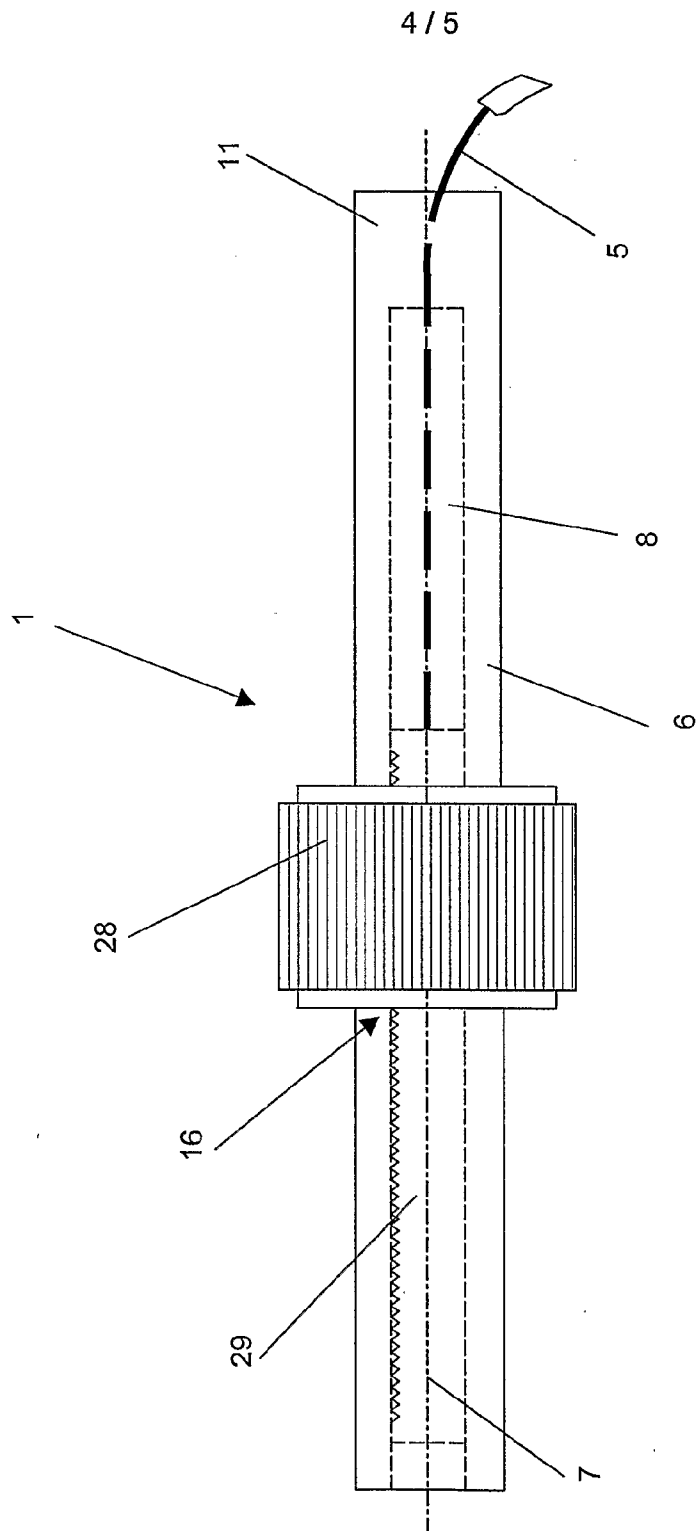

Fig. 6

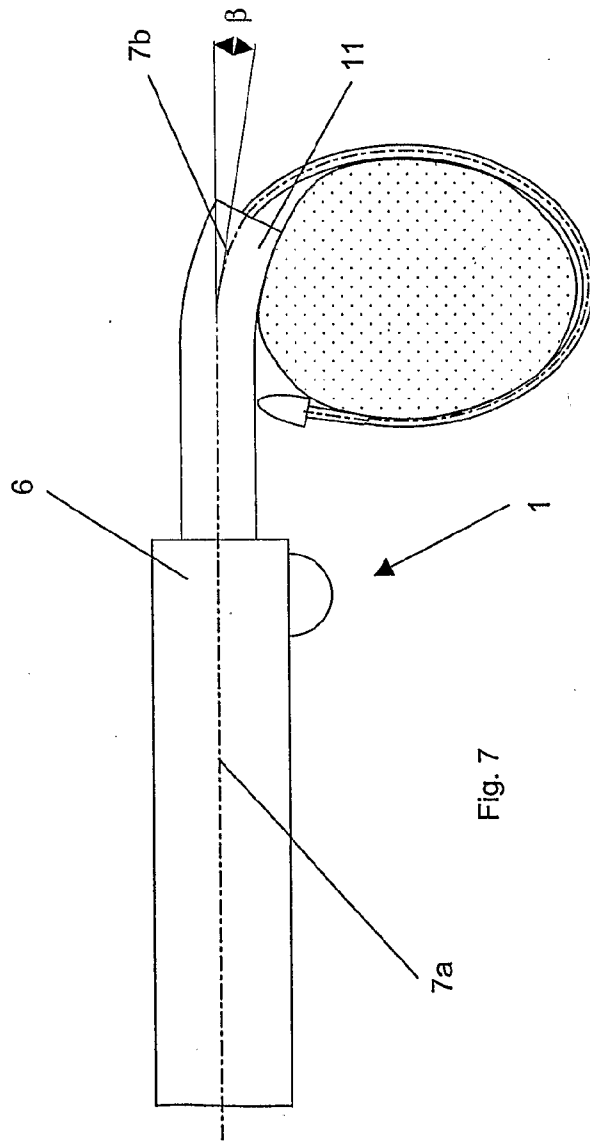

Fig. 7