

(57) **Abrégé(suite)/Abstract(continued):**

opening TH become higher than predetermined values. A clutch-torque capacity storage section stores a clutch-torque capacity reference map in which a clutch-torque capacity is set as a function of at least the engine speed NE from between the engine speed NE and the throttle valve opening TH. A clutch-torque capacity correction section corrects the clutch-torque capacity reference map so that the clutch-torque capacity reduces in a proportionally reducing manner in response to the difference between the engine speed NE and a start permission speed NE0 when a start permission is issued. An oil pressure controlling section connects the clutch with the clutch-torque capacity obtained in accordance with the corrected clutch-torque capacity map to start the vehicle.

ABSTRACT OF THE DISCLOSURE

To allow a clutch to be connected smoothly to enhance the comfortable ride upon start even if the current speed is higher than a start permission speed. A start permission decision section issues a start permission when an engine speed NE and a throttle valve opening TH become higher than predetermined values. A clutch-torque capacity storage section stores a clutch-torque capacity reference map in which a clutch-torque capacity is set as a function of at least the engine speed NE from between the engine speed NE and the throttle valve opening TH. A clutch-torque capacity correction section corrects the clutch-torque capacity reference map so that the clutch-torque capacity reduces in a proportionally reducing manner in response to the difference between the engine speed NE and a start permission speed NE0 when a start permission is issued. An oil pressure controlling section connects the clutch with the clutch-torque capacity obtained in accordance with the corrected clutch-torque capacity map to start the vehicle.

CLUTCH CONTROLLING APPARATUS FOR VEHICLE

FIELD OF THE INVENTION

5 This invention relates to a clutch controlling apparatus for a vehicle, and more particularly to a clutch controlling apparatus for a vehicle which can allow smooth start of the vehicle even if the engine speed has a dispersion arising from various conditions of the engine when start map control is entered after start permission decision.

10

BACKGROUND OF THE INVENTION

Conventionally, an automatic clutch controlling apparatus which can carry out start of a vehicle smoothly has been investigated. For example, Japanese Patent Laid-Open No. 2007-139120 proposes an automatic clutch controlling apparatus
15 which can learn a clutch transmission torque characteristic which is used for clutch control upon starting. Meanwhile, Japanese Patent Laid-Open No. 2006-336853 proposes a clutch controlling apparatus which can carry out appropriate fastening force control for target torque regardless of drop of the coefficient of friction of a starter clutch or increase of the clearance between plates.

20

The clutch controlling apparatus disclosed in Japanese Patent Laid-Open No. 2007-139120 and Japanese Patent Laid-Open No. 2006-336853 can cope with a case in which the clutch stroke amount varies by deterioration of a clutch apparatus or the like. However, the clutch controlling apparatus fail to pay
25 attention to the fact that an appropriate clutch-torque capacity of a starter clutch requires correction when a difference appears between an engine speed at a point of time of start permission decision and a current engine speed upon clutch connection.

For example, when start permission decision is made and start map control is entered, a dispersion appears in the engine speed depending upon various conditions of the engine. For example, where start permission conditions that the throttle opening is greater than 1 degree and the engine speed is higher than 1,200 rpm are set, since the engine speed corresponding to the throttle opening of 1 degree differs among different engines, start of the engine may be permitted at the engine speed of 1,200 rpm, or start of the engine may be permitted at 1,400 rpm. A start map sets the clutch-torque capacity using at least the engine speed as a parameter, and as the engine speed increases, a higher clutch-torque capacity is required. Therefore, a difference in start feeling appears depending upon the engine speed.

Originally it is desirable that an engine starts by torque of a similar level if the throttle valve opens by a similar degree. However, since a start capacity of a clutch corresponding to an engine speed is read in from the start map, a clutch-torque capacity which differs depending upon a difference of the engine speed upon start permission is read in, and this gives rise to a difference in feeling of starting when the clutch is connected.

Particularly in fast idle, since the engine speed is high with respect to the throttle opening, if the throttle valve opening becomes large during fast idle and start is permitted, then a large clutch-torque capacity corresponding to the high engine speed during the fast idle is read. Therefore, since the clutch-torque capacity with which high torque transmission is carried out is set with respect to the degree of throttle opening operation, there is a subject that the start torque becomes different from that by the feeling of the driver.

The object of the present invention resides in provision of a clutch controlling apparatus for a vehicle which can correct, when start permission conditions are satisfied, the value of the clutch-torque capacity with respect to the engine speed to enhance the start feeling.

SUMMARY OF THE INVENTION

The present invention has a first characteristic in that a clutch controlling apparatus for a vehicle wherein a clutch for transmitting driving force from an engine to a transmission in response to a start permission when both of an engine speed and a throttle opening become higher than a predetermined start permission speed and a predetermined permission opening is connected to start the vehicle includes a clutch-torque capacity reference map in which a clutch-torque capacity is set as a function of at least the engine speed from between the engine speed and the throttle opening, and map correction means for correcting the clutch-torque capacity reference map so that the clutch-torque capacity is reduced in a proportionally reducing manner in response to a difference between the engine speed and the start permission speed when the start permission is issued, and the clutch is connected with the clutch-torque capacity obtained in accordance with the clutch-torque capacity map corrected by the map correction means to start the vehicle.

Further, the present invention has a second characteristic that the map correction means is configured so as to correct the clutch-torque capacity reference map when the difference between the engine speed and the start permission speed at the time of the start permission is issued is higher than a predetermined value.

Further, the present invention has a third characteristic that the map correction means is configured so as to linearly interpolate the clutch-torque capacity reference map in response to the difference between the engine speed and the start permission speed when the start permission is issued.

Further, the present invention has a fourth characteristic that the map correction means is configured so as to correct the clutch-torque capacity reference map by multiplication by a coefficient set in advance in response to the difference between the engine speed and the start permission speed when the start permission is issued.

Furthermore, the present invention has a fifth characteristic that the engine includes a fast idle apparatus.

Where the engine speed (current speed) when a start permission is issued is higher than the start permission speed, if the clutch-torque capacity reference map is used in response to the current speed to determine a clutch-torque capacity, then the transmission torque upon starting sometimes becomes so high that the vehicle cannot be started smoothly. According to the invention having the first characteristic, when the current speed is higher than the start permission speed, the map is corrected such that the clutch-torque capacity may have an appropriate value in response to the difference between the current speed and the start permission speed. Therefore, the clutch-torque capacity corresponding to the start permission speed can be used to start connection of the clutch. Accordingly, the clutch connects smoothly, and the clutch-torque capacity increases in response to later increase of the engine speed. Consequently, the output torque of the engine can be transmitted to the transmission with certainty.

15

According to the invention having the second characteristic, since it is configured such that the clutch-torque capacity reference map is corrected when the difference between the current speed and the start permission speed is greater than the predetermined value, only when a start permission is issued at a comparatively low speed, the clutch-torque capacity reference map can be used to start the vehicle.

20

According to the invention having the third or fourth characteristic, the clutch-torque capacity reference map can be corrected simply and easily.

25

According to the invention having the fifth characteristic, when the throttle value is opened to carry out a starting operation while the engine having the fast idle apparatus is operating at a fast idle speed extremely higher than the start permission speed, such a situation that the clutch-torque capacity reference map is referred to at the fast idle speed to determine a clutch-torque capacity can be prevented.

30

BRIEF DESCRIPTION OF THE DRAWINGS

Preferred embodiments of the invention are shown in the drawings, wherein:

FIG. 1 is a block diagram showing a driving system for a vehicle including a clutch controlling apparatus according to an embodiment of the present invention.

5

FIG. 2 is a view showing an example of a clutch-torque capacity map.

FIG. 3 is a view showing an example of the clutch-torque capacity map before and after correction.

10

FIG. 4 is a flow chart of principal part of clutch control.

DETAILED DESCRIPTION OF THE PREFERRED EMBODIMENTS

In the following, an embodiment of the present invention is described with reference to the drawings. FIG. 1 is a block diagram showing a driving system for a vehicle including a clutch controlling apparatus according to an embodiment of the present invention. The driving system for a vehicle includes an engine 1, a clutch 2, a transmission 3, and a clutch controlling apparatus 4. The clutch controlling apparatus 4 includes a clutch ECU 5, a driver 6, a hydraulic circuit 7 and a slave cylinder 8. The oil pressure of the hydraulic circuit 7 is adjusted by a piston (not shown) which is driven by a motor 17 as a hydraulic actuator.

The clutch 2 is provided between an output power shaft (crankshaft) of the engine 1 and an input power shaft of the transmission 3 and connects or disconnects rotational driving force of the engine 1 to or from the transmission 3. The clutch 2 is driven by oil pressure supplied to the slave cylinder 8 from the hydraulic circuit 7 which is driven by the driver 6 in response to a result of processing by the clutch ECU 5. The output power shaft of the transmission 3 is connected to a driving wheel WR (rear wheel) through a chain or the like.

A fast idle apparatus 9 is provided for the engine 1. The fast idle apparatus 9 keeps, upon starting of the engine, a valve provided in a path for bypassing a throttle valve of the engine 1 at a high opening so that the engine speed becomes

a fast idle speed. Then, after the engine starts, the fast idle apparatus 9 decreases the opening in response to a rise of the engine temperature, that is, in response to progress of the warming up operation, to automatically adjust the fast idling speed of the engine. After the warming up, the fast idle apparatus 9 fully closes
5 the valve body.

The clutch ECU 5 includes a start permission decision section 10, a clutch-torque capacity storage section 11, a clutch-torque capacity correction section (map correction means) 12 and an oil pressure controlling section 13. The start
10 permission decision section 10, clutch-torque capacity storage section 11, clutch-torque capacity correction section 12 and oil pressure controlling section 13 can be configured from a microcomputer.

As sensors used for control in the clutch ECU 5, a throttle opening sensor 14 and
15 an engine speed sensor 15 are provided. The sensors are widely known and are used commonly as those used for ignition control, fuel injection control and so forth of the start permission decision section 10.

The clutch-torque capacity storage section 11 stores a map in which the clutch-
20 torque capacity, that is, the fastening force of the clutch 2, is set as a function of the engine speed NE. This map is set such that the clutch-torque capacity increases in response to the engine speed NE (hereinafter described).

The start permission decision section 10 decides based on the throttle valve
25 opening TH detected by the throttle opening sensor 14 and the engine speed NE detected by the engine speed sensor 15 whether or not the vehicle is in a state in which start thereof can be permitted.

The clutch-torque capacity correction section 12 corrects the map stored in the
30 clutch-torque capacity storage section 11 in response to the current engine speed NE. In particular, the clutch-torque capacity correction section 12 corrects the map in response to the engine speed NE when the clutch-torque capacity is determined in accordance with the map stored in the clutch-torque capacity storage section 11.

The oil pressure controlling section 13 compares a clutch oil pressure target value PCLtgt corresponding to the clutch-torque capacity corrected by the clutch-torque capacity storage section 11 and a clutch oil pressure PCL detected by an oil pressure sensor 16 provided for the hydraulic circuit 7 with each other and drives the driver 6 so that the clutch oil pressure PCL may converge to the clutch oil pressure target value PCLtgt. The driver 6 drives the motor 17, which is a hydraulic actuator, to control the oil pressure to be supplied from the hydraulic circuit 7 to the slave cylinder 8.

10

FIG. 2 is a view illustrating an example of the clutch-torque capacity map stored in the clutch-torque capacity storage section 11. Referring to the figure, the axis of abscissa indicates the engine speed NE, and the axis of ordinate indicates the clutch-torque capacity (that is, the oil pressure target value). As the clutch-torque capacity increases, the torque which can be transmitted from the engine 1 to the transmission 3 increases. A start permission speed NE0 is a permission speed set in advance to the start permission decision section 10, and the start permission decision section 10 outputs a start permission when the engine speed NE is higher than the start permission speed NE0 and besides the throttle valve is opened exceeding a predetermined throttle opening (for example, 0.8 degree).

15
20

When the throttle opening becomes the start permission opening, if the engine speed NE is NE0, then if the clutch-torque capacity is increased along the map, then the clutch can be connected smoothly. However, for example, in a case wherein the throttle opening becomes the start permission opening during fast idle, a fault occurs if the clutch-torque capacity is determined along this map. For example, if it is assumed that the fast idle speed is a speed NEidl higher than NE0, then if the throttle valve is opened exceeding the start permission opening during this fast idle, then the start permission decision section 10 issues a start permission. Consequently, a clutch-torque capacity CL1 is read out in accordance with the map of FIG. 2, and the hydraulic circuit 7 generates an oil pressure so that this clutch-torque capacity CL1 may be implemented. In particular, high torque is transmitted from the engine 1 to the transmission 3 from the beginning of the start, and the smoothness of the start is damaged.

25
30

Therefore, in the present embodiment, the value of the clutch-torque capacity map is corrected and read out in response to the engine speed at a point of time at which a start permission is issued.

5

FIG. 3 is a view showing a clutch-torque capacity map and indicating an outline of a correction technique of the clutch-torque capacity. Referring to FIG. 3, a map (reference map) M1 in which the clutch-torque capacity increases as the engine speed NE increases from a reference point R at which the start permission speed NE0 and the current engine speed NE coincide with each other is set. Here, it is assumed that the engine speed at a point of time at which the conditions for the throttle opening are satisfied and a start permission is issued is a fast speed NEidl. The point of the speed NEidl is set as a changing point S of the map. Then, a point at which the map M1 before correction and a map M2 after the correction join together and coincide with each other is represented as joining point G. The clutch-torque capacity while the engine speed varies from the start permission speed NE0 to an engine speed NEG at the joining point G corresponds to so-called half clutch and is a state wherein, with the clutch-torque capacity corresponding to the engine speed NE higher than the joining point, the clutch engages substantially without a slip.

10
15
20

If the engine speed is the fast speed NEidl at a point of time at which a start permission is issued, then the map M2 in which the clutch-torque capacity is varied from the changing point S determined at the point of the speed NEidl to the joining point G. Although the map M2 may be defined so that the clutch-torque capacity varies linearly in a linear function from the changing point S to the joining point G, it should be such a characteristic that the map M2 varies in proportion to the map M1 as seen in FIG. 3.

25

In particular, where the engine speeds corresponding to the points R, S and G are represented by NE0, NEidl and NEG, respectively, the map M1 is reduced in accordance with the value of the ratio between $(NEG - NEidl)$ and $(NEidl - NE0)$ to configure the map M2.

30

For example, if $(NE_{idl} - NE_0) : (NEG - NE_{idl})$ is 7 : 3, then a point at which the difference between the engine speed corresponding to an arbitrary point of the map M1 and the engine speed corresponding to the joining point G is internally divided at 7 : 3 is determined as a value of the map M2 corresponding to the
5 arbitrary point of the map M1. For example, a point CL10A on the map M2 corresponding to a point CL10 on the map M1 in FIG. 3 corresponds to a point at which the (engine speed NEG) - (engine speed NECL10 corresponding to the point CL10) is internally divided at 7 : 3.

10 Similarly, a point CL11A on the map M2 corresponding to a point CL11 on the map M1 corresponds to a point at which the (engine speed NEG) - (engine speed NECL11 corresponding to the point CL11) is internally divided at 7 : 3.

FIG. 4 is a flow chart illustrating a process of essential part of start. Referring to
15 FIG. 4, at step S1, an engine speed NE detected by the engine speed sensor 15 and a throttle valve opening TH detected by the throttle opening sensor 14 are read in. At step S2, whether or not the start permission conditions are satisfied is decided depending upon whether or not the engine speed NE is higher than the start permission speed NE0 and the throttle valve opening TH is higher than the
20 throttle valve opening TH. The start permission speed NE0 is, for example, 1,200 rpm, and the permission opening is 0.8 degree. In other words, if a throttle opening operation is carried out a little, then the start permission opening is reached.

25 If the start permission conditions are satisfied and a result of the decision at step S2 is in the affirmative, then the processing advances to step S3, at which the clutch-torque capacity map is corrected setting the current engine speed NE as the speed at the changing point S. An example of the correction is described with respect to FIG. 3.

30 At step S4, map control of determining the latch-torque capacity in accordance with the corrected map M2 and in accordance with the current engine speed NE and driving the hydraulic circuit 7 to connect the clutch is carried out. The clutch-torque capacity increases as the engine speed increases.

It is to be noted that, in the embodiment described above, an example wherein the clutch-torque capacity map is set as a function of the engine speed NE for the simplified description. However, the clutch-torque capacity map may be set as a
5 function of the engine speed NE and the throttle valve opening TH.

While, in the embodiment described above, the clutch-torque capacity correction section 12 produces the map M2 in which the clutch-torque capacity corresponding to the engine speed NE is proportionally reduced, the present
10 invention is not limited to this. For example, a correction coefficient (value lower than 1.0) may be set in response to the difference between the engine speed NE and the start permission speed NE0 such that a clutch-torque capacity set in the map M1 is multiplied by the correction coefficient to reduce the clutch-torque capacity.
15

It is to be noted that the correction of the clutch-torque capacity may be carried out not every time a start permission is issued but when the difference between the engine speed NE and the start permission speed NE0 at the time of a start permission is issued is greater than a predetermined value. Where the difference
20 between the start permission speed NE0 and the engine speed NE when a start permission is issued is small, correction of the clutch-torque capacity is not carried out. By this, cumbersome correction can be prevented and the burden on the clutch ECU can be reduced.

25 Although various preferred embodiments of the present invention have been described herein in detail, it will be appreciated by those skilled in the art, that variations may be made thereto without departing from the spirit of the invention or the scope of the appended claims.

THE EMBODIMENTS OF THE INVENTION IN WHICH AN EXCLUSIVE PROPERTY OR PRIVILEGE IS CLAIMED ARE DEFINED AS FOLLOWS:

1. A clutch controlling apparatus for a vehicle wherein a clutch for
5 transmitting driving force from an engine to a transmission in response to a start
permission when both of an engine speed and a throttle opening become higher
than a predetermined start permission speed and a predetermined permission
opening is controlled by clutch controlling means to start said vehicle,
characterized in that said clutch controlling means includes a clutch-torque
10 capacity reference map in which a clutch-torque capacity is set as a function of at
least the engine speed from between the engine speed and the throttle opening,
and map correction means for correcting the clutch-torque capacity reference
map so that the clutch-torque capacity is reduced in a proportionally reducing
manner in response to a difference between the engine speed and the start
15 permission speed when the start permission is issued, and that said clutch
controlling means is configured so as to connect said clutch with the clutch-
torque capacity obtained in accordance with the clutch-torque capacity map
corrected by said map correction means to start said vehicle.
- 20 2. The clutch controlling apparatus for the vehicle according to claim
1, characterized in that said map correction means is configured so as to correct
the clutch-torque capacity reference map when the difference between the engine
speed and the start permission speed at the time of the start permission is issued
is higher than a predetermined value.
- 25 3. The clutch controlling apparatus for the vehicle according to claim
1 or 2, characterized in that said map correction means is configured so as to
linearly interpolate the clutch-torque capacity reference map in response to the
difference between the engine speed and the start permission speed when the
30 start permission is issued.
4. The clutch controlling apparatus for the vehicle according to claim
1 or 2, characterized in that said map correction means is configured so as to
correct the clutch-torque capacity reference map by multiplication by a

coefficient set in advance in response to the difference between the engine speed and the start permission speed when the start permission is issued.

5. The clutch controlling apparatus for the vehicle according to any
5 one of claims 1 to 4, characterized in that said engine includes a fast idle
apparatus.

FIG. 1

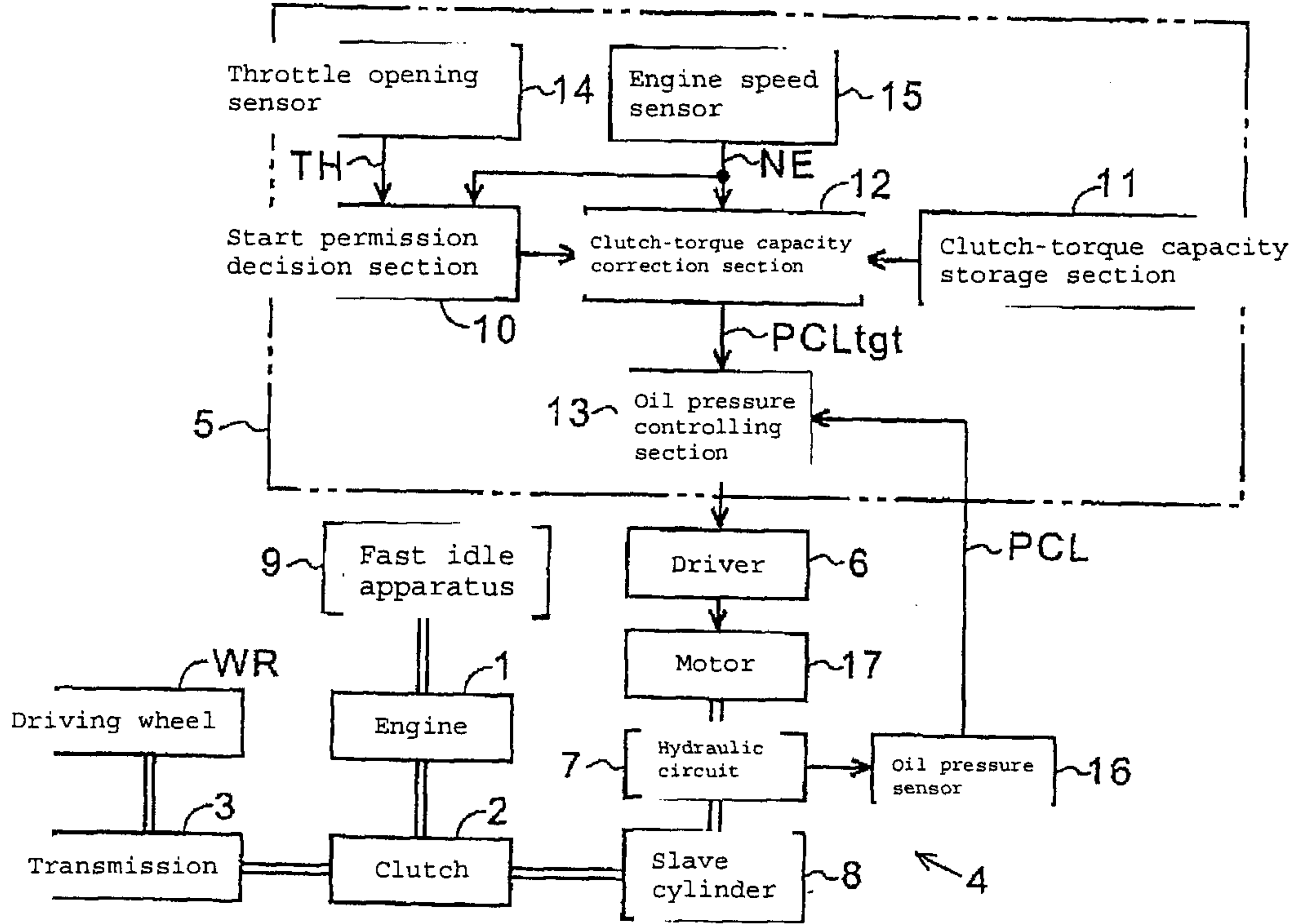

FIG. 2

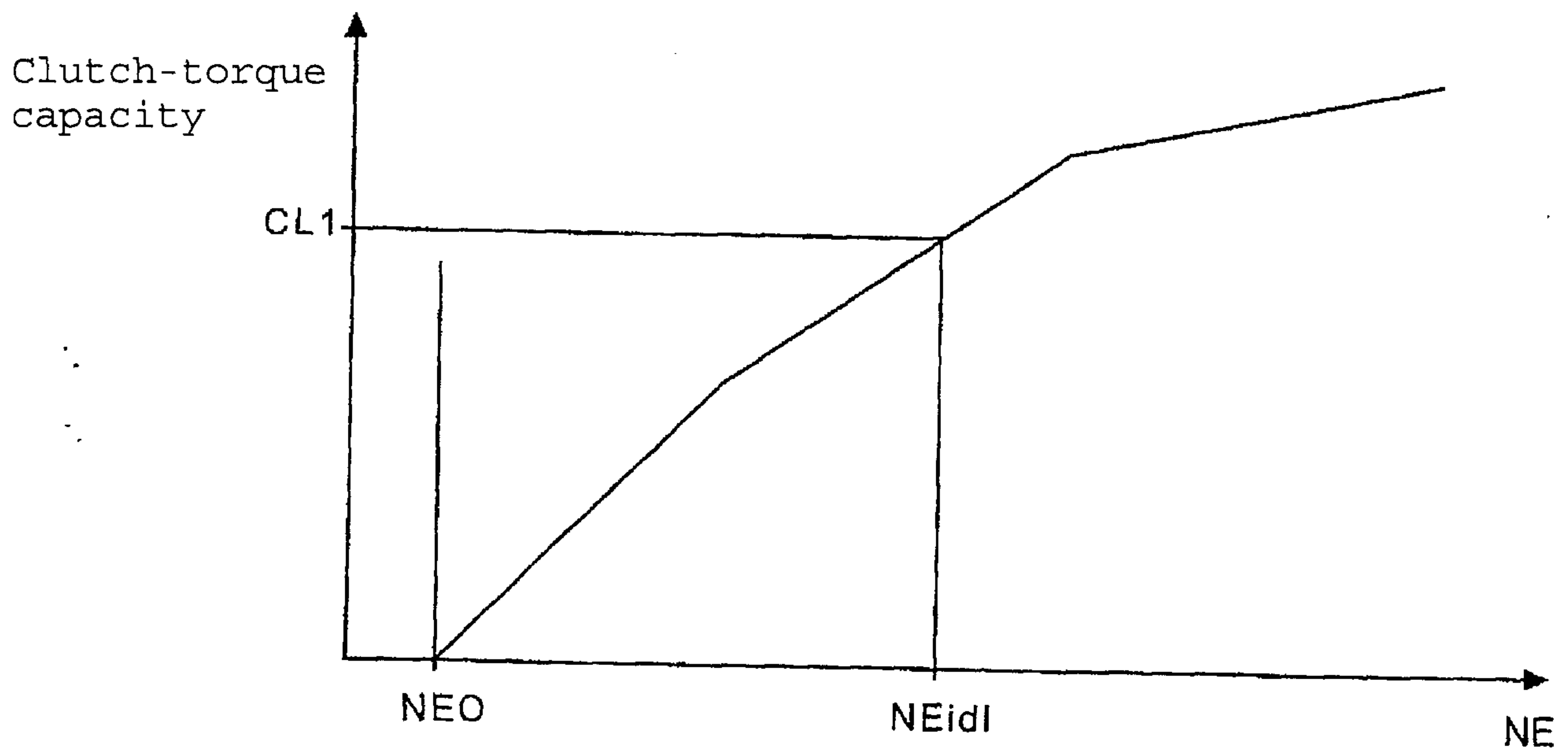

FIG. 3

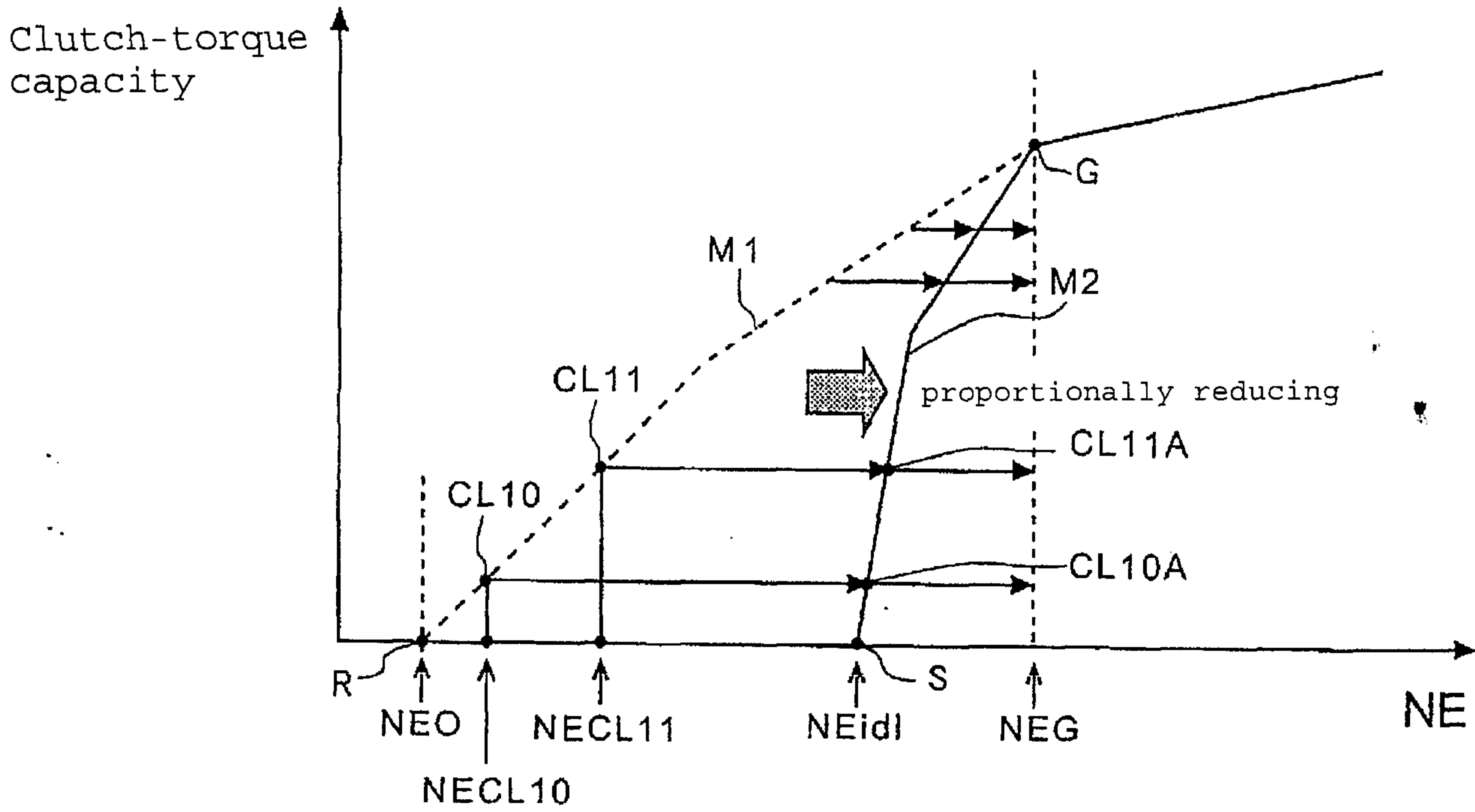

FIG. 4

