

No. 611,706.

Patented Oct. 4, 1898.

W. T. PARSONS.
TRACE FASTENER.

(Application filed Jan. 23, 1897. Renewed Mar. 5, 1898.)

(No Model.)

Fig. 1.

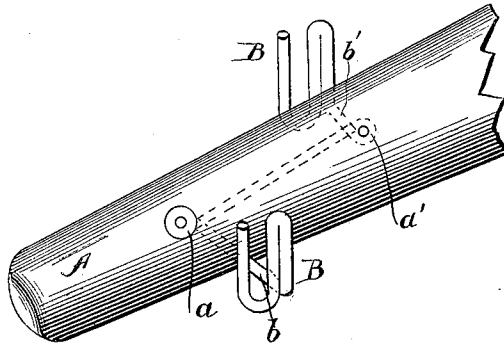
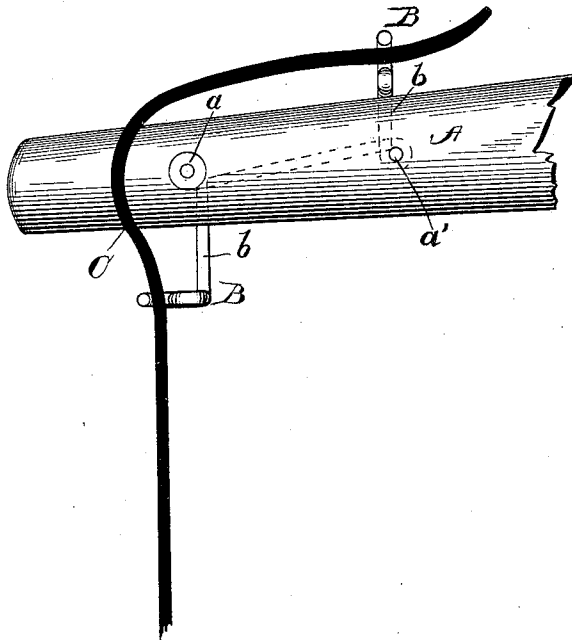

Fig. 2.



Witnesses:
J. M. Fowler Jr.
John B. Peyton

Inventor
Willard T. Parsons
By *Rankin Sweet*
Attorney

UNITED STATES PATENT OFFICE.

WILLARD T. PARSONS, OF SPRINGBOROUGH, PENNSYLVANIA, ASSIGNOR OF
THREE-FOURTHS TO ANSON PARSONS, OF SAME PLACE, AND D. W.
TRYON, WARREN W. WHITE, ELMER M. BLAKESLEE, AND J. P. GRIF-
FITH, OF SPARTANSBURG, PENNSYLVANIA.

TRACE-FASTENER.

SPECIFICATION forming part of Letters Patent No. 611,706, dated October 4, 1898.

Application filed January 23, 1897. Renewed March 5, 1898. Serial No. 672,779. (No model.)

To all whom it may concern:

Be it known that I, WILLARD T. PARSONS, a citizen of the United States, and a resident of Springborough, in the county of Crawford and State of Pennsylvania, have invented new and useful Improvements in Trace-Fasteners; and I do hereby declare the following to be a full, clear, and exact description of said invention, reference being had to the accompanying drawings, and to the letters of reference marked thereon, which form a part of this specification.

My invention relates to improvements in devices for securing traces to whiffletrees; and it has for its object to provide novel and simplified means which will permit of the easy and quick attachment and detachment of the trace to or from the whiffletree.

To these ends my invention consists of the novel details of construction and general arrangement of parts, as will be hereinafter fully described.

In the accompanying drawings, Figure 1 represents a perspective view of one end of a whiffletree having my device applied thereto; and Fig. 2, a top plan view of the same, showing the trace properly fastened into position.

Similar letters of reference indicate like parts in both figures of the drawings.

As will be seen from said drawings, my invention consists of a simple and inexpensive device formed of a single piece of stout wire having the central portion thereof provided with two loops *a a*, arranged in substantially the same horizontal plane, whereby the device may be secured to the whiffletree A, one near each end, by suitable rivets. Projecting from said central portion in reverse directions and at approximately right angles thereto are provided arms or extensions *b b'*, the outer ends of which are bent upwardly and then downwardly and upwardly, there-

by forming the U-shaped loops B, open at the top, and said loops being disposed at right angles to each other, so as to reduce friction upon the end of the trace C when in position, as well as to assist in securely holding it in place.

I do not confine myself to the particular construction shown, as it is evident that the device may be formed of malleable metal and suitably secured to the ends of the whiffletree.

In the operation of my invention the eye of the trace C is slipped over the end of the whiffletree A and the end of the trace adjusted in the rear loop B, the opposite or draft end of the trace being also adjusted in the forward loop B, so as to equalize the strain not only upon the trace but equally as well upon the whiffletree itself. It will thus be seen that the trace may be easily and rapidly attached to or detached from the whiffletree in the simplest and best possible manner and at the same time serves to strengthen the whole construction.

Having thus described my invention, I claim as new and useful—

The herein-described trace-fastener, the same consisting of the central portion formed with loops *a a'*, arranged in substantially the same horizontal plane and provided with arms or extensions *b b'* arranged in reverse directions and at approximately right angles to said central portion, said arms or extensions having their outer ends bent upwardly then downwardly and upwardly whereby the U-shaped loops B are formed, and the complete device being formed from a single piece of stout wire, substantially as described.

In testimony whereof I affix my signature in presence of two subscribing witnesses.

WILLARD T. PARSONS.

Witnesses:

D. W. TRYON,
C. A. LAMB.