

H. KASLOPSKY.
 SASH LOCK.
 APPLICATION FILED AUG. 13, 1909.

992,878.

Patented May 23, 1911.

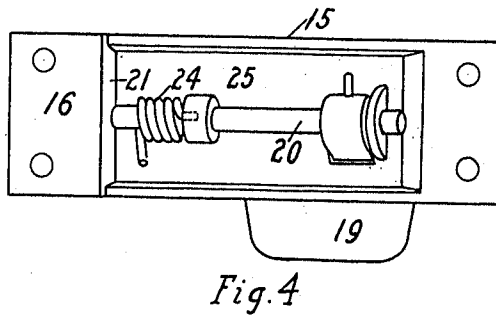
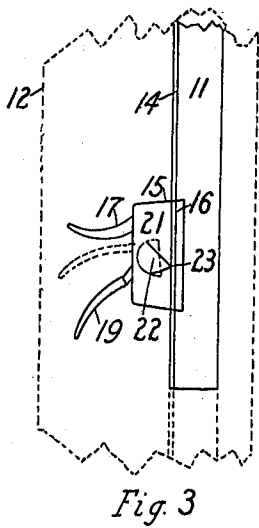
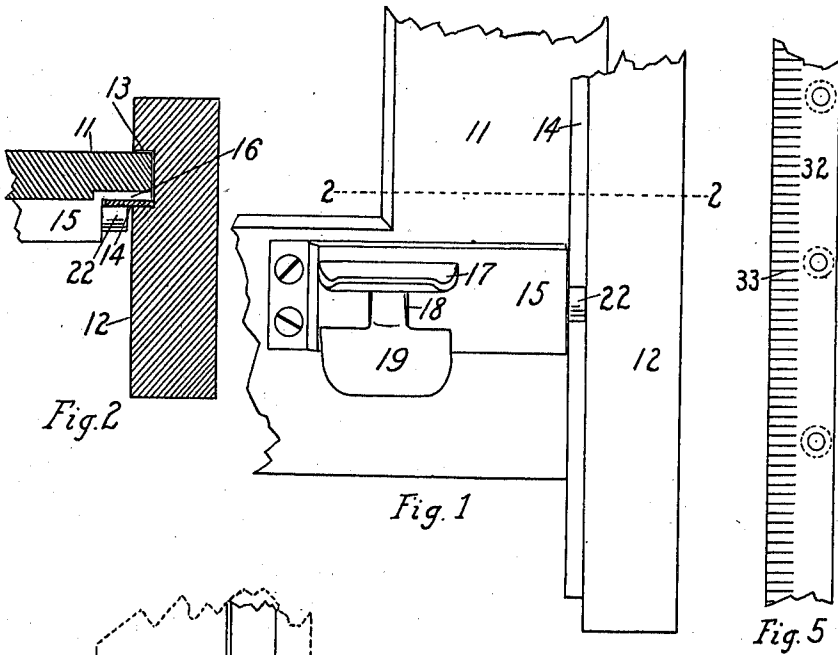

WITNESSES:
B. M. Dolhurst
J. H. Otto

Henry Kaslopsy
 INVENTOR

BY *Jos. L. Cooper*
 ATTORNEY

UNITED STATES PATENT OFFICE.

HENRY KASLOPSKY, OF SCHENECTADY, NEW YORK.

SASH-LOCK.

992,878.

Specification of Letters Patent. Patented May 23, 1911.

Application filed August 13, 1909. Serial No. 512,668.

To all whom it may concern:

Be it known that I, HENRY KASLOPSKY, a citizen of Austria-Hungary, and a resident of Schenectady, New York, have invented a new and useful Improvement in Sash-Locks, of which the following is a specification.

My invention relates to sash locks for sliding windows, and is particularly adapted to car windows, in that it provides means for holding them at any desired height under any conditions of vibration or jolting, and for readily releasing them when desired.

The object of my invention is to provide a simple, durable, economical and efficient sash lock, the various features of which will appear in the specification and be pointed out in the claims.

In the drawings, Figure 1 shows a portion of a window sash and a jamb with my device secured thereto; Fig. 2 is a transverse section through the plane 2—2, Fig. 1; Fig. 3 is an end elevation of the device of Fig. 1, the jamb being shown in dotted lines; Fig. 4 is a rear elevation of the sash lock detached; Fig. 5 is a broken elevation of a modified form of locking strip.

Referring to the first four figures of the drawings, 11 designates a window sash or casing, and 12 the jamb formed with the usual recess 13, in which the sash 11 slides, the recess in this case being of a width greater than the thickness of the sash to admit a locking strip 14, which is secured against the front edge of the recess and extends therebeyond, its rear face being in sliding contact with the sash 11.

15 is the box or case of the lock adapted to be secured to the face of the casing 11 and, as shown, provided with a flange or plate portion 16 in a plane rearwardly of but parallel with the body of the case, so as to be let into the face of the sash 11 adjacent its edge, see Fig. 2. On the face of the case 15 is a thumb-piece 17 of usual form, beneath which is a slot or aperture 18, through which passes the shank of a lever or finger-piece 19. Mounted in suitable bearings in the box 15 is a longitudinal shaft 20, which passes out through the end 21 of the box in front of the portion 16, and is there provided with an integral or rigidly secured cam 22, shown in the drawings as formed with a biting edge 23. The shank of the finger-piece 19 is rigidly secured to this shaft 20, on which is also mounted a coiled spring 24, secured, as shown, by a collar 25 on the

shaft, the free end of the spring bearing against the inner face of the case 15.

The parts being assembled as shown in the drawings, the operation of the device is as follows: Whether the sash 11 is in its closed or any desired open position, the cam 22 is automatically forced by the spring 24 to engage with, in the present instance, to bite into, the front face of the locking strip 14, the cam being so constructed that any vibration or jar causes it to engage with the greater force. It will be seen that the rear face of the strip 14 has sliding contact with the sash 11, or rather as shown with the face of the plate 16 of the case 15, so that the strip being held between the plate and the cam, requires no considerable rigidity. To lower the window, the operator raises the finger-piece 19, thereby releasing the cam 22, the finger-piece serving also as a means for raising the window, the thumb-piece 17 serving in like manner to force the window down, if it is tightly fitted in its frame.

In Fig. 5 of the drawings, I have shown the laterally projecting or cam engaging part of the locking strip 32 as transversely notched or corrugated at 33, it being understood that this form of strip may be substituted for the smooth strip 14 previously shown. This, however, will usually be unnecessary, especially if the strip is made of brass, bronze or like relatively soft metal, while the cam 22 is of a harder metal, as steel.

I do not desire to be considered as limited to the particular construction shown, as mechanical changes within considerable limits may be made in the device without departing from my invention.

What I claim is:

1. In combination with a window sash and a jamb, a sash locking device comprising a metal strip secured to the front face of the jamb recess and extending therebeyond with its rear face in sliding contact with the front face of the sash; and a lock case secured on the front face of the sash, a shaft in said case, a cam at the end of said shaft and exterior of said case, a finger piece on said shaft and passing out of the front face of said case for rotating said shaft; said cam having a biting edge constructed and fitted to engage the front face of said strip, whereby said strip is tightly but releasably held between the front face of said sash and the edge of said cam.

2. In combination with a window sash and a jamb, a sash locking device comprising a metal strip secured to the front face of the jamb recess and extending therebeyond
5 with its rear face in sliding contact with the front face of said sash; and a lock case secured on the front face of said sash, a shaft in said case, a finger piece on said shaft and passing out of the front face of said case
10 for rotating said shaft, a cam at the end of said shaft and exterior of said case, said cam

having a biting edge constructed and fitted to engage with the front face of said strip, a spring on said shaft for normally holding said cam in engaging position, whereby said strip is releasably held between the front face of said sash and the edge of said cam. 15

HENRY KASLOPSKY.

Witnesses:

EDWARD A. WELTI,
JOSEPH EBINGER.

Copies of this patent may be obtained for five cents each, by addressing the "Commissioner of Patents, Washington, D. C."
