

DE NARD W. B. YOUNG.
 APPARATUS FOR RAPIDLY AGING SOLIDIFIED PLASTIC ARTICLES.
 APPLICATION FILED NOV. 26, 1917.

1,294,591.

Patented Feb. 18, 1919.

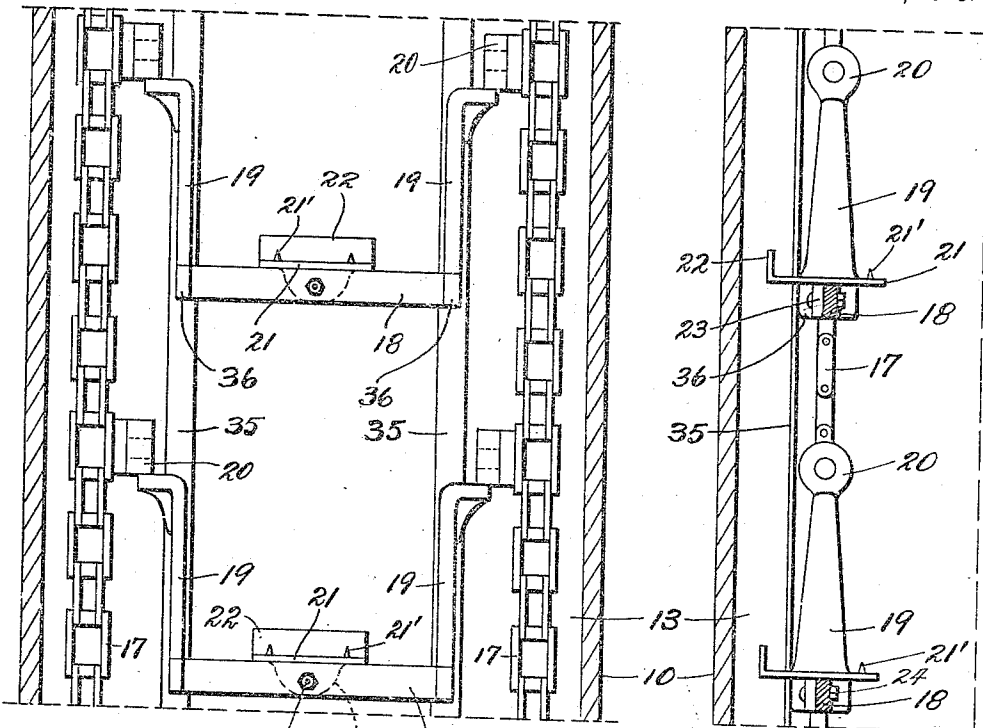

Fig. 1.

Fig. 2.

Fig. 3.

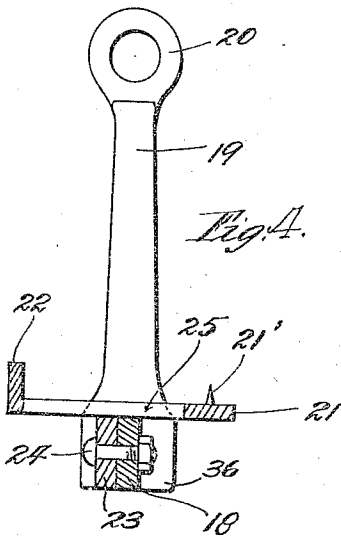
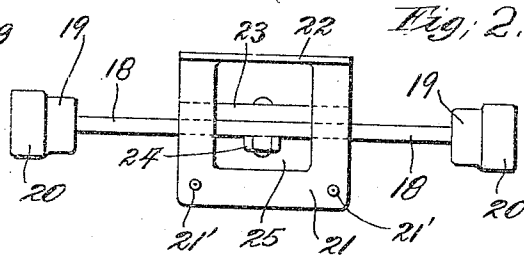

Fig. 4.

Inventor
 DeNard W. B. Young.
 By William Jackson
 Attorney

UNITED STATES PATENT OFFICE.

DE NARD W. B. YOUNG, OF PHILADELPHIA, PENNSYLVANIA, ASSIGNOR TO SOAP WORKS EQUIPMENT COMPANY, A CORPORATION OF PENNSYLVANIA.

APPARATUS FOR RAPIDLY AGING SOLIDIFIED PLASTIC ARTICLES.

1,294,591.

Specification of Letters Patent.

Patented Feb. 18, 1919.

Original application filed January 10, 1916, Serial No. 71,150. Divided and application filed March 27, 1917, Serial No. 157,636. Divided and this application filed November 26, 1917. Serial No. 203,917.

To all whom it may concern:

Be it known that I, DE NARD W. B. YOUNG, a citizen of the United States, residing at Philadelphia, in the county of Philadelphia and State of Pennsylvania, have invented a certain new and useful Improved Apparatus for Rapidly Aging Solidified Plastic Articles, of which the following is a specification, the same being a division of my application for Letters Patent serially numbered 157,636, filed March 27, 1917, which application is a division of application Serial Number 71,150 filed Jan. 10, 1916, patented Nov. 13, 1917, No. 1,246,515.

The present invention, broadly stated, relates to improved apparatus for rapidly aging solidified plastic articles and has more particular relation to the rapidly aging of bars, blocks or cakes of soap and while the herein disclosed apparatus is adapted for the rapid aging of other solidified plastics, it is particularly fitted for the aging of what is termed in the trade bar-soap, and for illustrative purposes, the following description will be restricted thereto.

In the manufacture of bar-soap, as now practised, soap is first molded, then cut into slabs and finally cut into elongated bars and placed upon racks where the soap remains for days at a time to dry or age, the length of time depending a great deal upon existing weather conditions. The bars of soap thus dried or aged are then cut into cakes of proper size for commercial use. As thus manufactured, bar-soap is commercially unsatisfactory for a number of reasons. For instance, by permitting soap to stand for long periods of time, as above described, it develops a surface efflorescence or formation of fine, white, salt crystals. Further, undue penetration of dryness takes place thus causing shrinkage of soap and resultant loss of weight. Still further, the bars of soap often become distorted or mis-shaped through long standing and perfume used for scenting the soap rapidly exudates. These and other disadvantageous results all tend to render the method now practised exceedingly slow, unsatisfactory and expensive.

This invention has for its principal object to overcome these disadvantageous features and provide improved and novel apparatus

for the rapid aging of bar-soap whereby a more commercially valuable product is obtained than is now upon the market, in a much more rapid manner and at considerably less expense. A further object of the present invention is to provide apparatus of the continuous feed and discharge type in which the holders or supports for soap or other solidified plastic articles to be aged are maintained in unchanging position relative to the endless conveyer from the time of receiving the article until the time of discharging the same. A still further object of the present invention resides in the providing of new and novel holders or supports for soap or other plastic articles to be aged. Other and further objects of the present invention reside in the providing of general details of construction and in the arrangement, connection and construction of parts as will hereinafter more fully appear.

With these and other objects in view the invention consists of the improvements hereinafter described and finally claimed.

The nature, characteristic features and scope of the invention will be more fully understood from the following description taken in connection with the accompanying drawings forming part hereof and in which:

Figure 1 is a fragmentary view in section of apparatus embodying features of the invention.

Fig. 2 is an end view of Fig. 1.

Fig. 3 is a top or plan view of a holder or support for a solidified plastic article, and

Fig. 4 is a view in central section of a holder or support.

For the purpose of illustrating my invention, I have shown in the accompanying drawings one form thereof which is at present preferred by me, since the same has been found in practice to give satisfactory and reliable results, although it is to be understood that the various instrumentalities of which my invention consists can be variously arranged and organized and that my invention is not limited to the precise arrangement and organization of the instrumentalities as herein shown and described.

In the drawings 10 designates a generally rectangular structure or housing preferably

constructed of insulating material possessed of non-heat conveying properties. This structure interiorly considered is divided transversely into three compartments, one of which designated 13 is shown in the drawings. Endless chain belts 17—17 are present for travel through said structure or housing. Intermediate the height of said compartment 13, pairs of sprocket wheels 17' are present for guiding the outermost runs of said chain belts at an inclination inwardly so as to bring said outermost runs into perpendicular alinement with sprocket wheels 16'', the purpose of which will presently appear. Pivotaly connected to and suspended between the chain belts 17—17 are a multiplicity of soap holders or supports constructed so as to normally hang in a horizontal position during their passage through the above mentioned compartments. Each soap-holder comprises a substantially U-shaped hanger preferably formed in one piece and embracing a thin, apertured, cross-piece or bar 18 and a pair of uprights 19 slightly bent outwardly in a horizontal manner at their upper ends and each terminating in a lug 20 apertured to receive a pivot pin for suspending the hanger with respect to the chain belts. Each upright is enlarged or reinforced at its bottom for a purpose to presently appear. Disposed upon and at right angles to each cross-piece 18 is a one-piece saddle embracing a flat plate 21 having an upwardly extended lip 22 at its rear end having a pair of soap engaging points 21' at its front end and having a central, depending, apertured lug 23. This apertured lug is detachably secured to the cross-piece of a hanger as by a bolt 24. The plate 21 is centrally cut away as at 25, in order that little soap resisting surface be present and at the same time to lighten construction.

Suitably mounted within compartment 13 and in juxtaposition to that portion of the endless conveyer which moves at an inclination over the sprocket wheel 17 are a pair of fixed finger-pieces 34, preferably of wood, for overturning individual bars of soap to cause the same to fall upon the apron 33. These finger-pieces are so disposed that the bars, blocks or cakes of soap in their travel abut thereagainst and as a the endless con-

veyer moves along, a soap bar is lifted free of a plate 21 and is overturned upon the apron 33, as fully described in my co-pending application for Letters Patent filed Nov. 26, 1917, and Serial Number 203,918. As the hangers are U-shaped, the soap bars may be readily overturned onto the apron 33 through the moving hanger. In order that the hangers may be bodily shifted to follow the inclined runs of the endless chain belts, a pair of fixed guides 35 are present. As shown in Figs. 1 and 2, these guides comprise thin, narrow strips positioned one upon each side of the conveyer and in the path of travel of a hanger upright, so that the enlargements or reinforcements designated 36 and hereinbefore referred to, of the hanger uprights track upon said guides 35. It will thus be seen that the hangers in their travel come in contact with different forms of guides which necessitates a special form of hanger in order that operation of parts may be effected.

It will now be apparent that I have devised a novel and useful apparatus which embodies the features of advantage enumerated as desirable in the statement of the invention and the above description and while I have in the present instance shown and described the preferred embodiment thereof which has been found in practice to give satisfactory and reliable results, it is to be understood that the same is susceptible of modification in various particulars without departing from the spirit or scope of the invention or sacrificing any of its advantages and that I have in mind the treating of plastic articles other than soap.

What I claim is:

In apparatus of the character stated, a pair of endless chain belts and a series of hangers carried by said belt chains, each hanger being provided with a support having a substantially central opening and a marginal surrounding portion the top surface of which is plane and has projected upwardly therefrom pointed projections at the front of the support and which has projected upwardly therefrom a flanged part at the rear thereof.

In testimony whereof, I have hereunto signed my name.

DE NARD W. B. YOUNG.