



US 20140100534A1

(19) **United States**  
(12) **Patent Application Publication**  
**Beasley et al.**

(10) **Pub. No.: US 2014/0100534 A1**  
(43) **Pub. Date: Apr. 10, 2014**

(54) **SEPTUM FEATURE FOR IDENTIFICATION OF AN ACCESS PORT**

(71) Applicant: **C.R. Bard, Inc.**, Murray Hill, NJ (US)

(72) Inventors: **Jim C. Beasley**, Phoenix, AZ (US);  
**Eddie K. Burnside**, Bountiful, UT (US);  
**Jay Gerondale**, Longmont, CO (US);  
**Steven Tallarida**, Mansfield, MA (US);  
**Kelly B. Powers**, North Salt Lake, UT (US)

(73) Assignee: **C. R. BARD, INC.**, Murray Hill, NJ (US)

(21) Appl. No.: **14/104,354**

(22) Filed: **Dec. 12, 2013**

**Related U.S. Application Data**

(63) Continuation of application No. 13/471,219, filed on May 14, 2012, now Pat. No. 8,608,713, which is a continuation of application No. 11/320,223, filed on Dec. 28, 2005, now Pat. No. 8,177,762, which is a continuation-in-part of application No. 10/374,000, filed on Feb. 25, 2003, now Pat. No. 7,713,251, which

is a continuation of application No. 09/582,406, filed on Jun. 23, 2000, now Pat. No. 6,527,754, filed as application No. PCT/US99/28695 on Dec. 3, 1999.

(60) Provisional application No. 60/658,518, filed on Mar. 4, 2005, provisional application No. 60/111,257, filed on Dec. 7, 1998.

**Publication Classification**

(51) **Int. Cl.**  
*A61M 39/04* (2006.01)  
*A61M 39/02* (2006.01)  
(52) **U.S. Cl.**  
CPC ..... *A61M 39/04* (2013.01); *A61M 39/0208* (2013.01)  
USPC ..... **604/288.02**

(57) **ABSTRACT**

A power-injectable access port, and a method of identifying a subcutaneously implanted power-injectable access port. The power-injectable access port includes a body capturing a septum that covers a cavity defined by the body, and a pattern of protrusions extending from an outer surface of the septum away from the cavity, the pattern of protrusions detectable through palpation to identify the access port as a power-injectable access port.

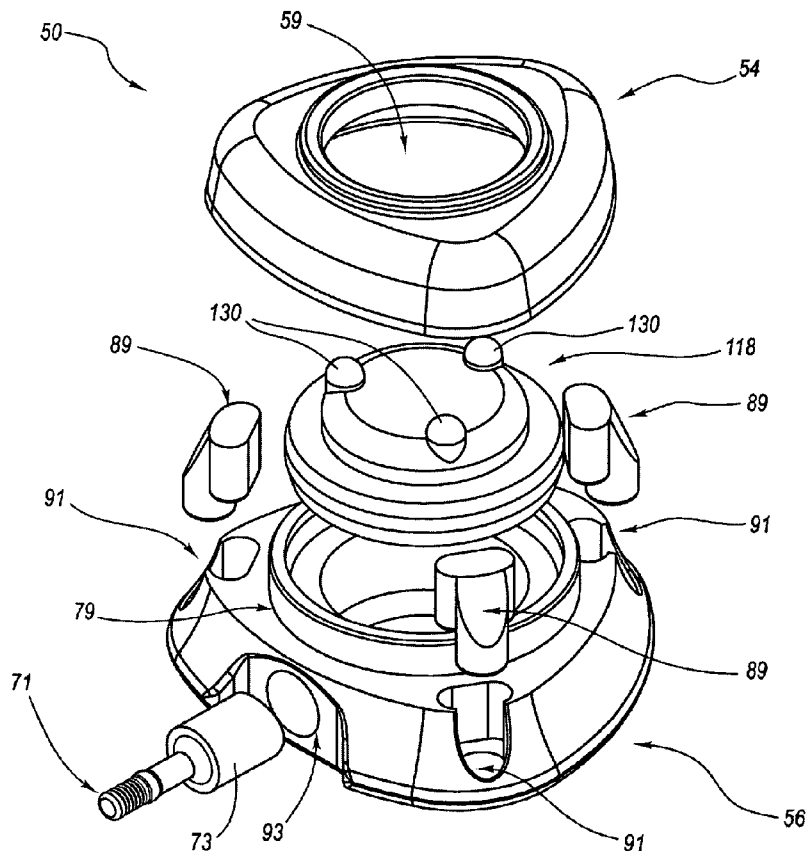

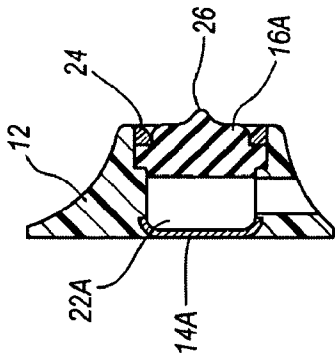
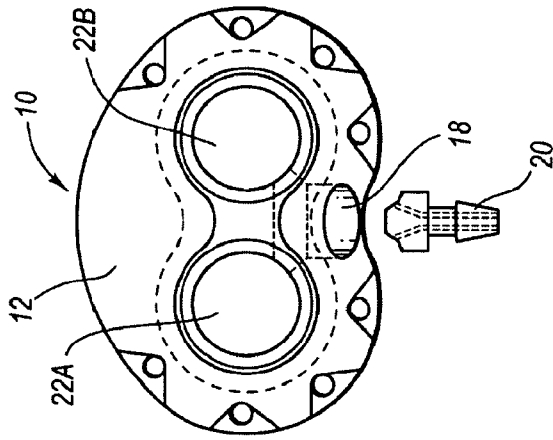

FIG. 1A

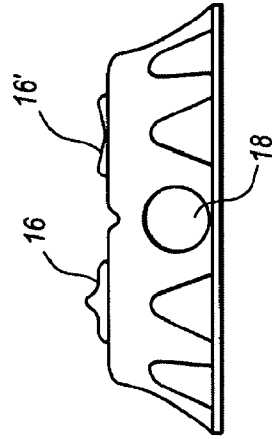

FIG. 1B

FIG. 1D

FIG. 1C

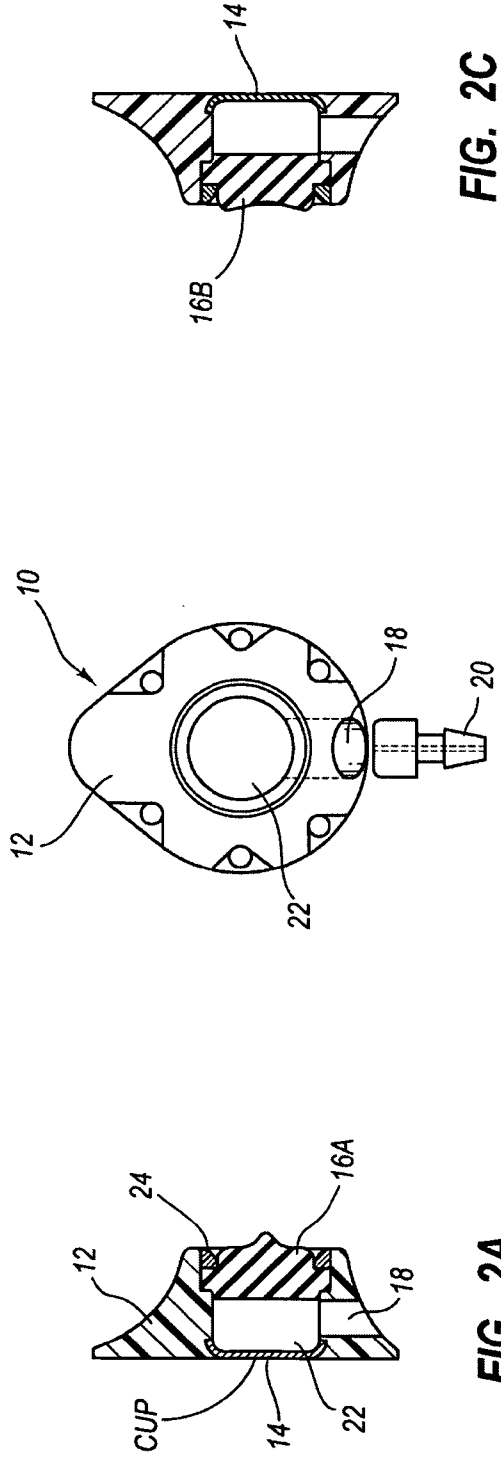

FIG. 2C

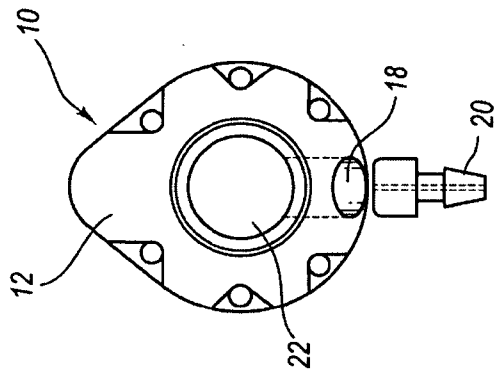

FIG. 2B

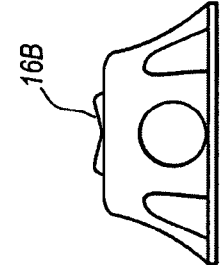

FIG. 2E

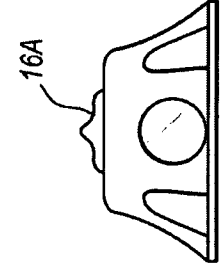

FIG. 2D

FIG. 2A

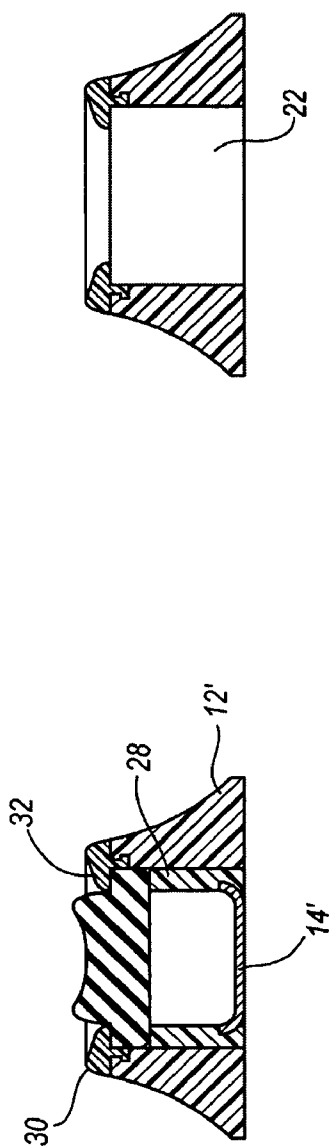

FIG. 3A

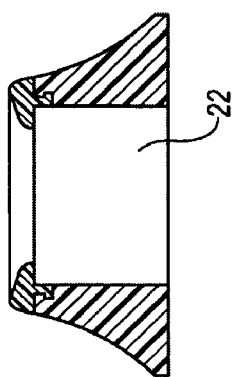

FIG. 3B

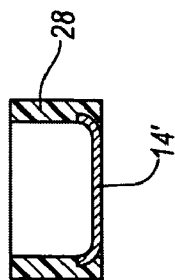
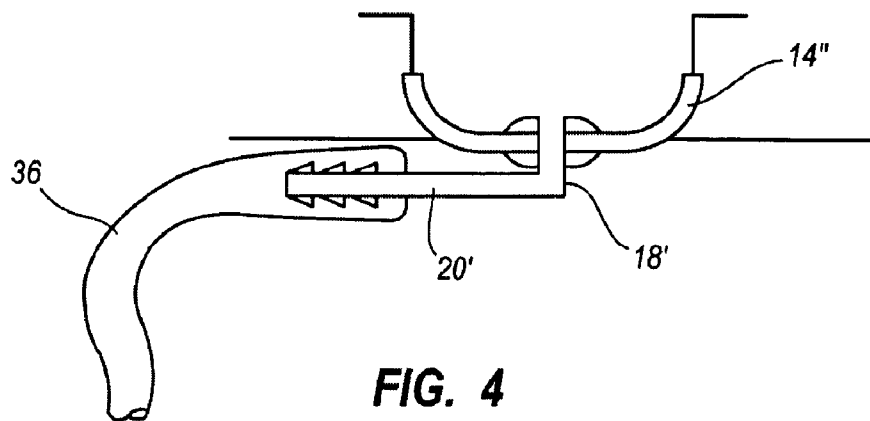

FIG. 3D



FIG. 3C



**FIG. 4**

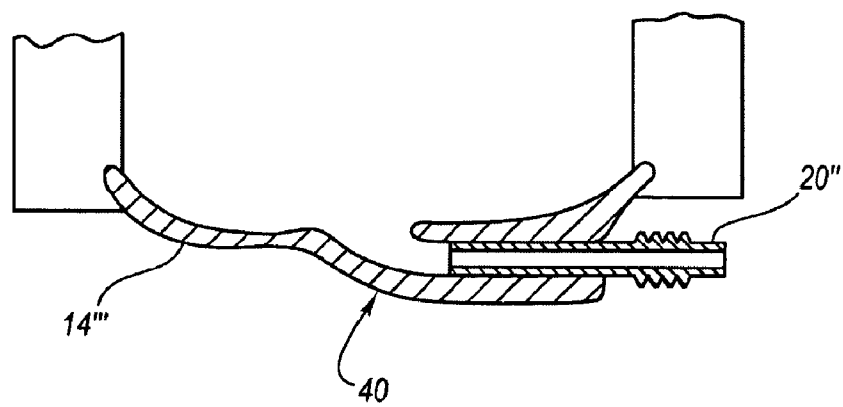

**FIG. 5A**

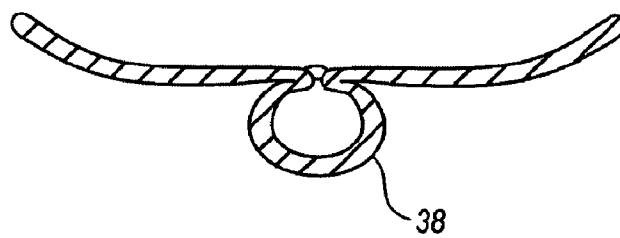

**FIG. 5B**

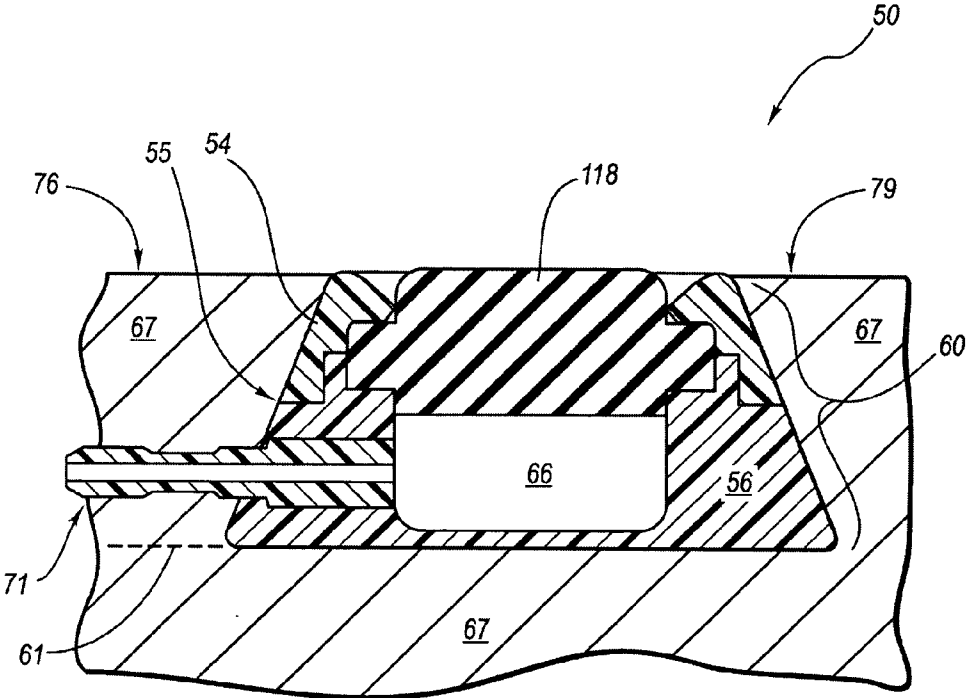

FIG. 6

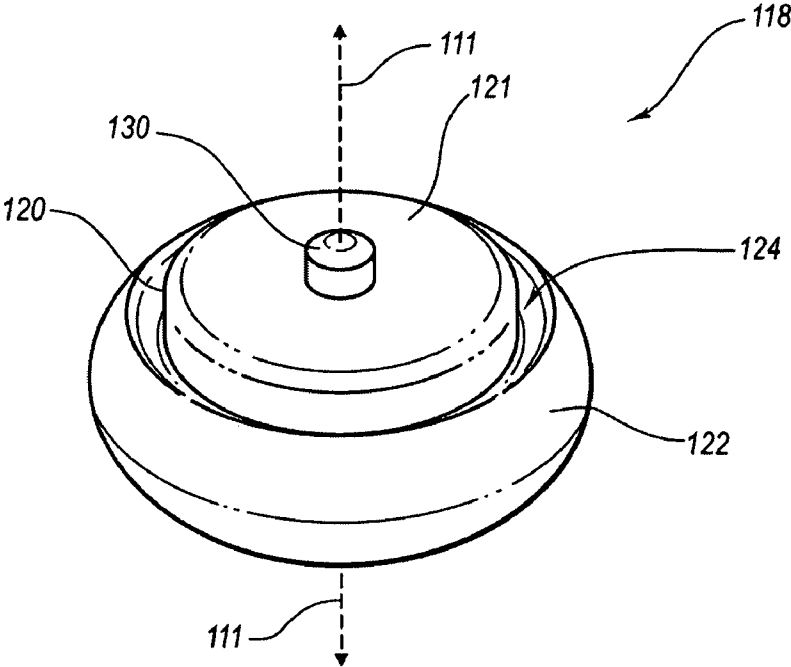

FIG. 7

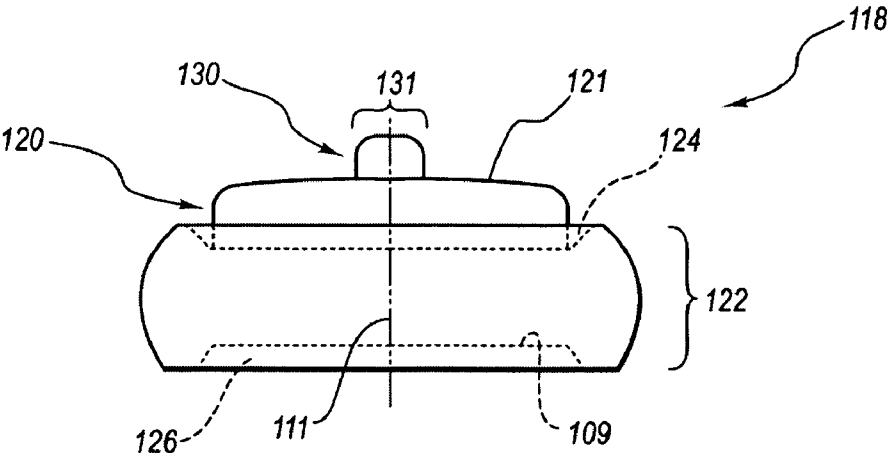
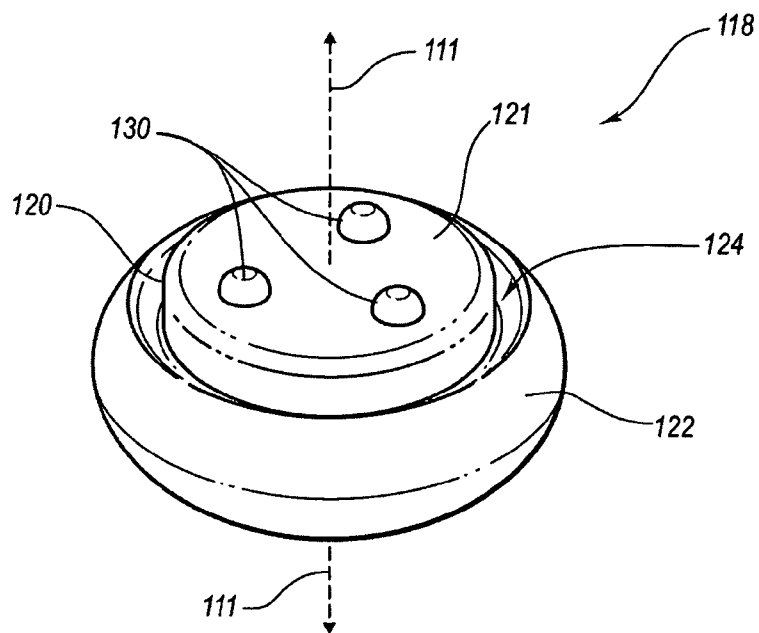
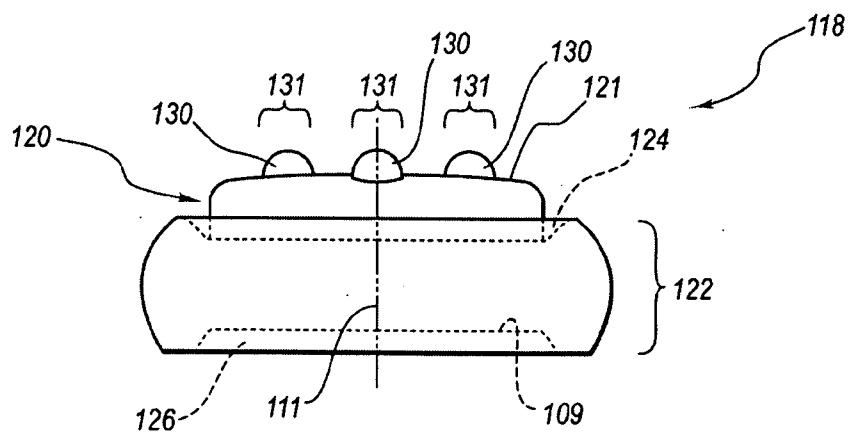

FIG. 8

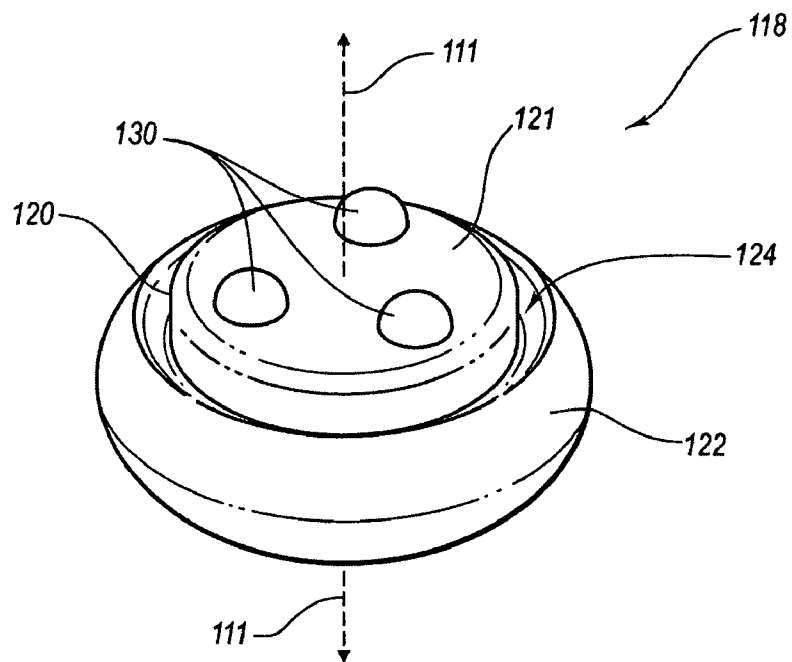

**FIG. 9**

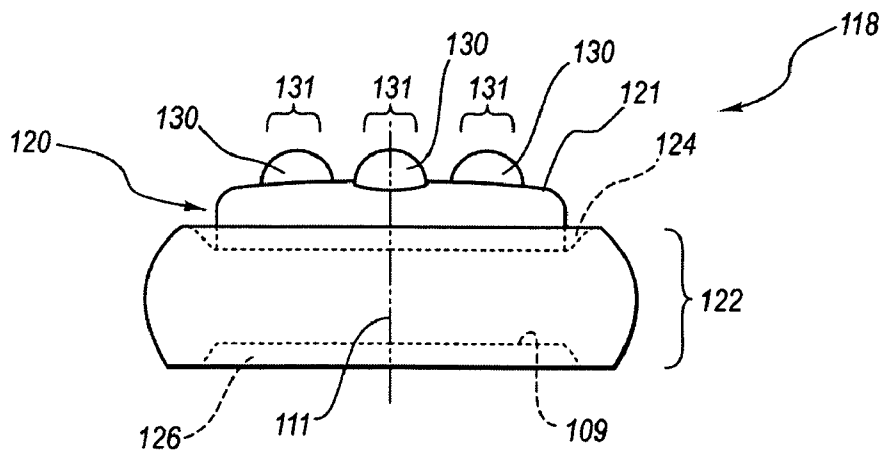

**FIG. 10**

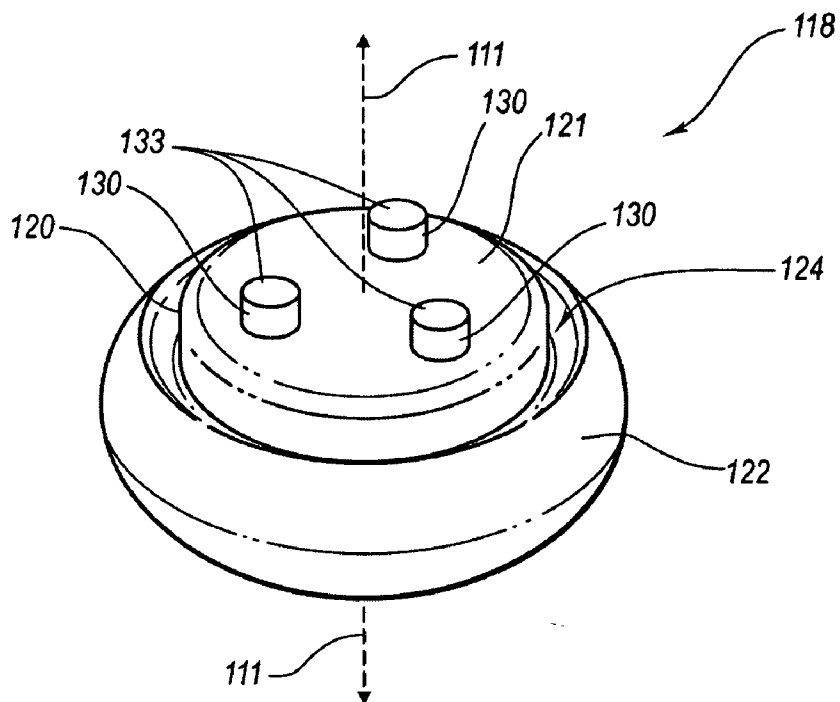



**FIG. 11**



**FIG. 12**



**FIG. 13**

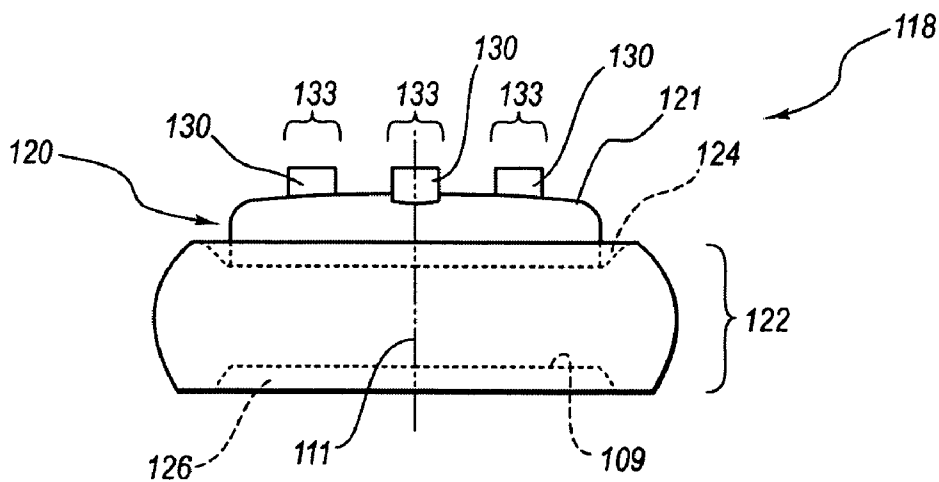

**FIG. 14**

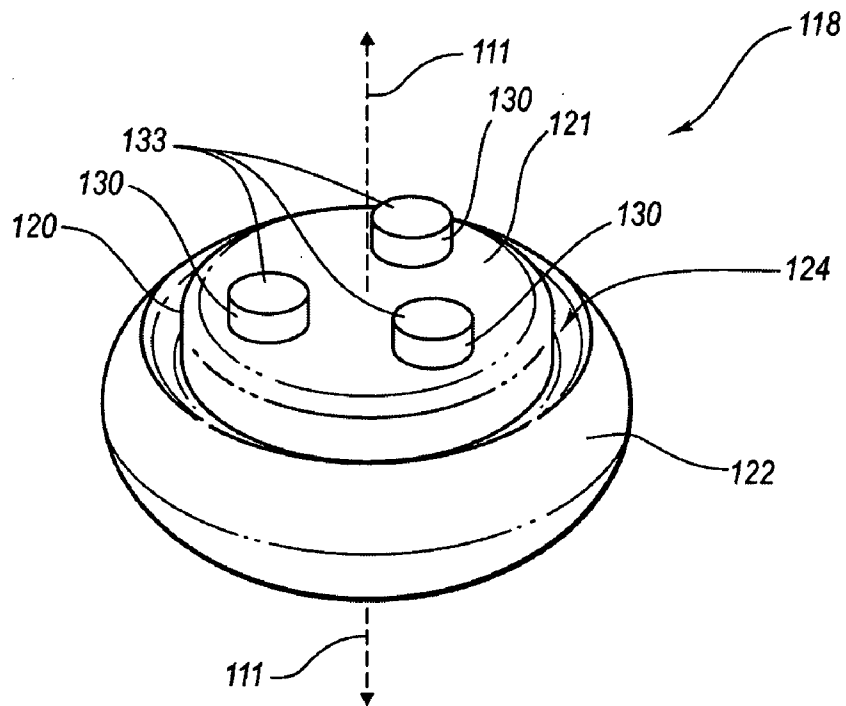

FIG. 15

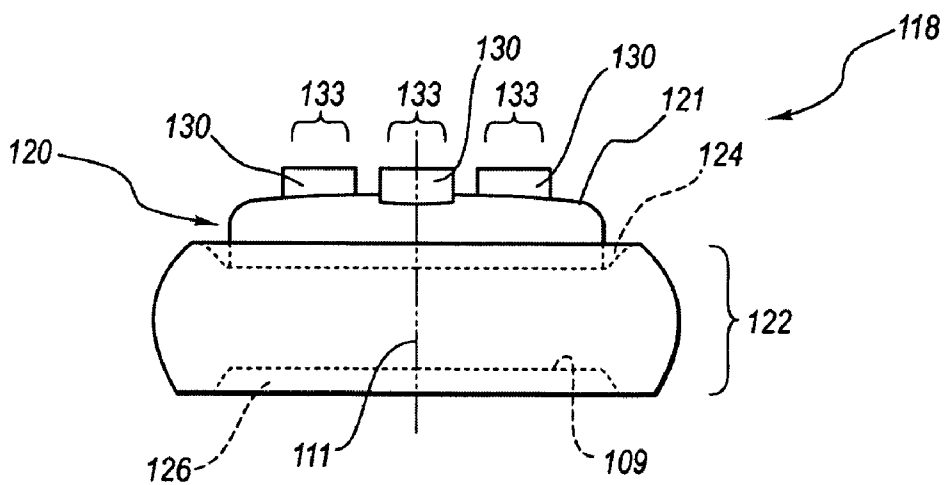

FIG. 16

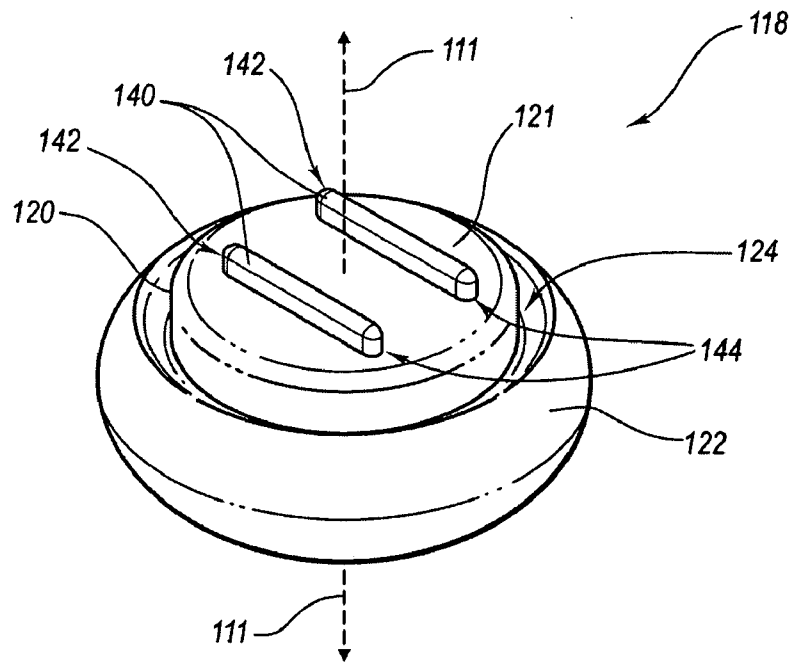

FIG. 17

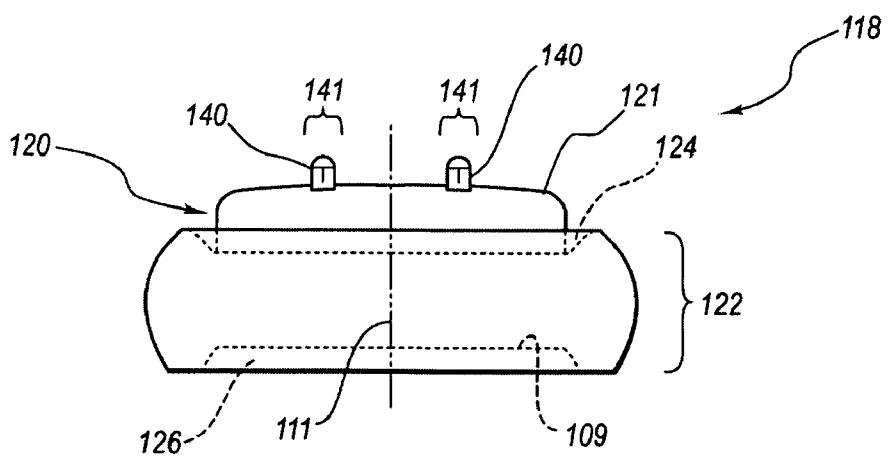

FIG. 18

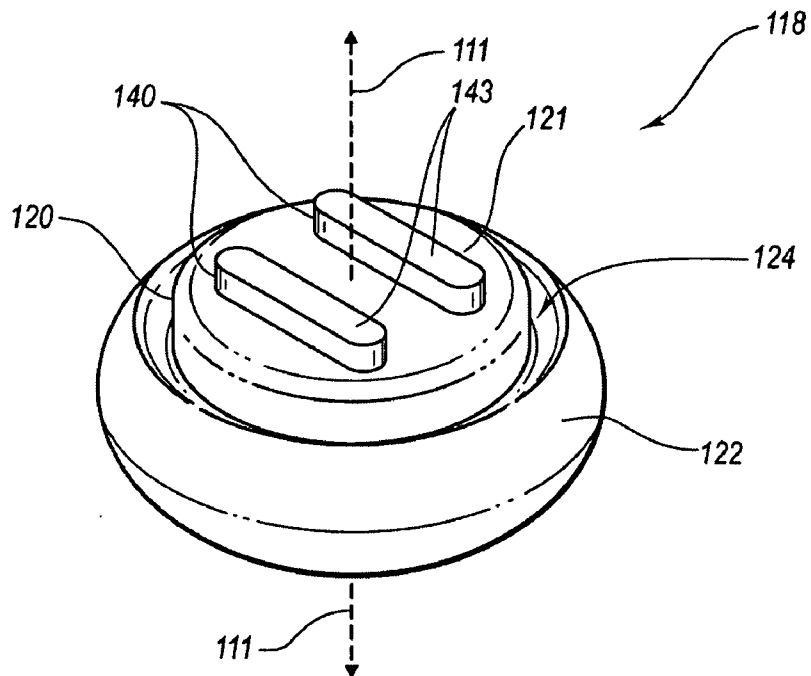

FIG. 19

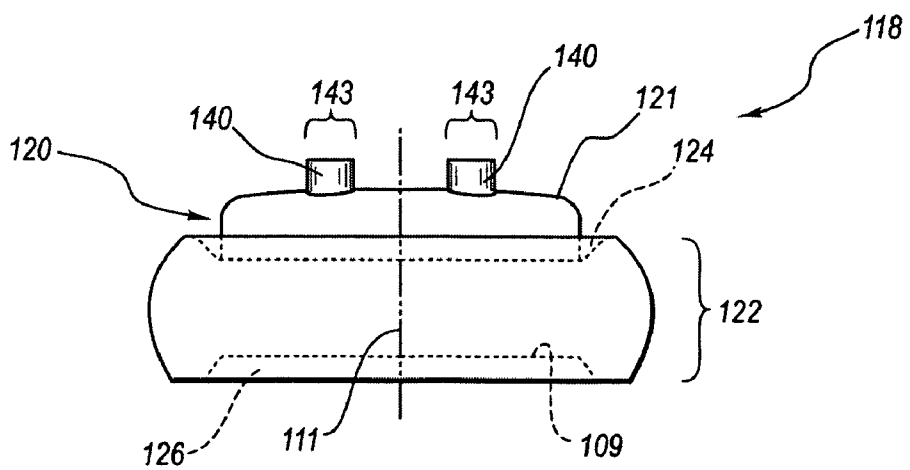

FIG. 20

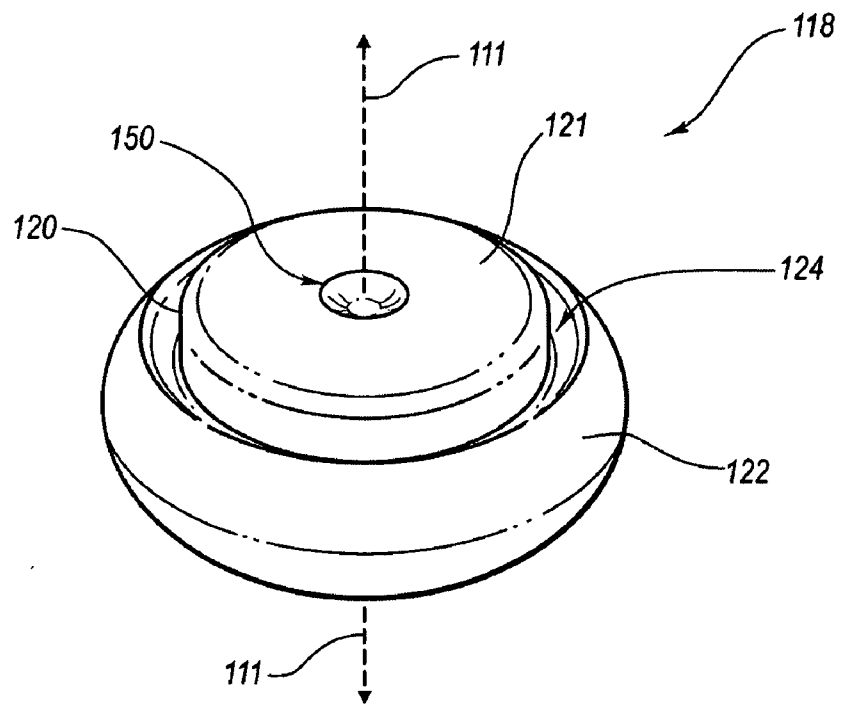

FIG. 21

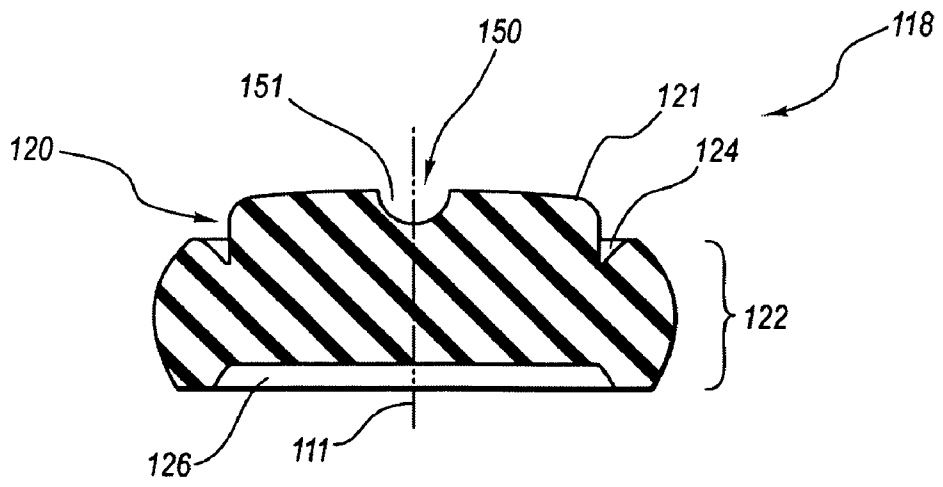

FIG. 22

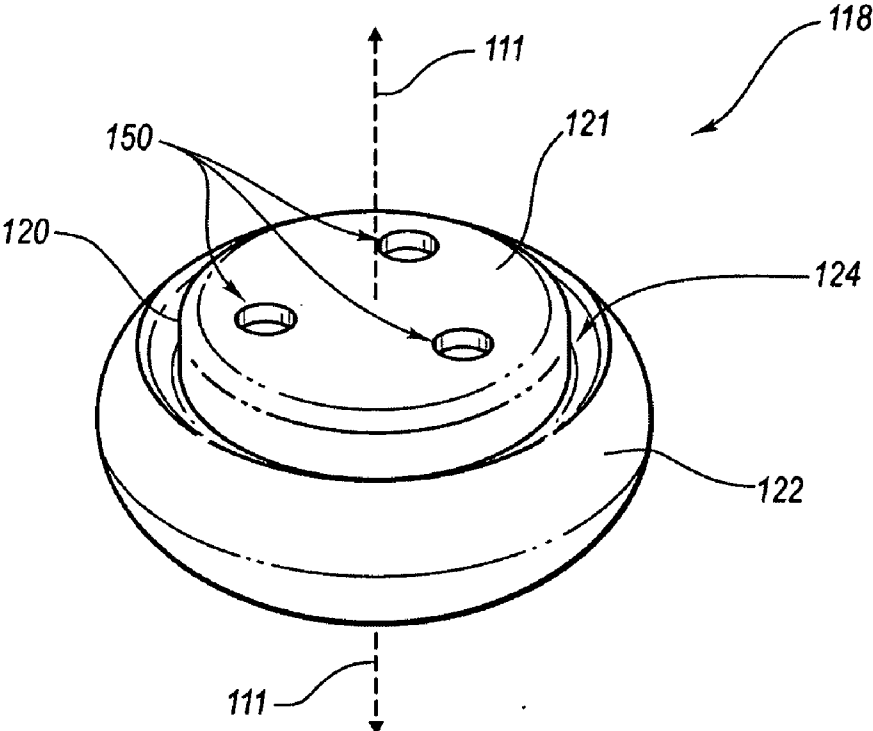

FIG. 23

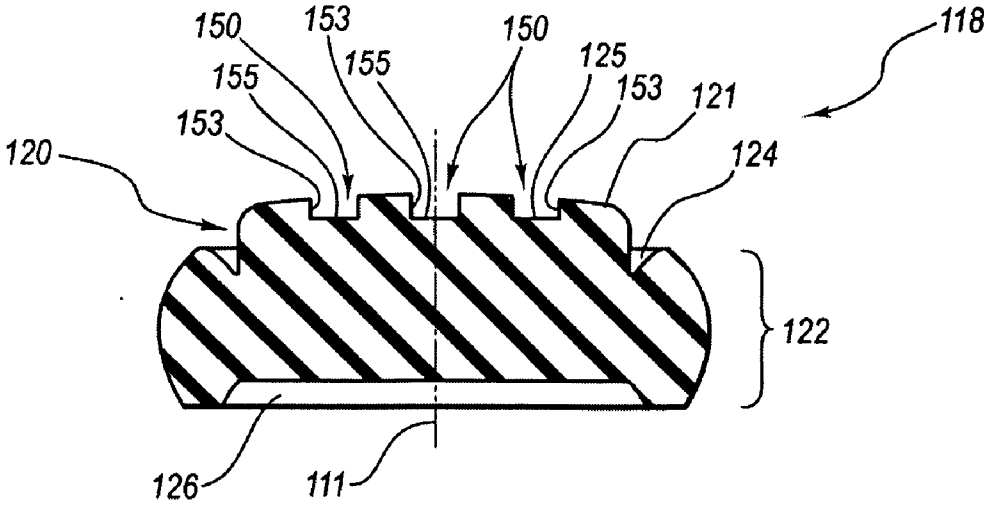

FIG. 24

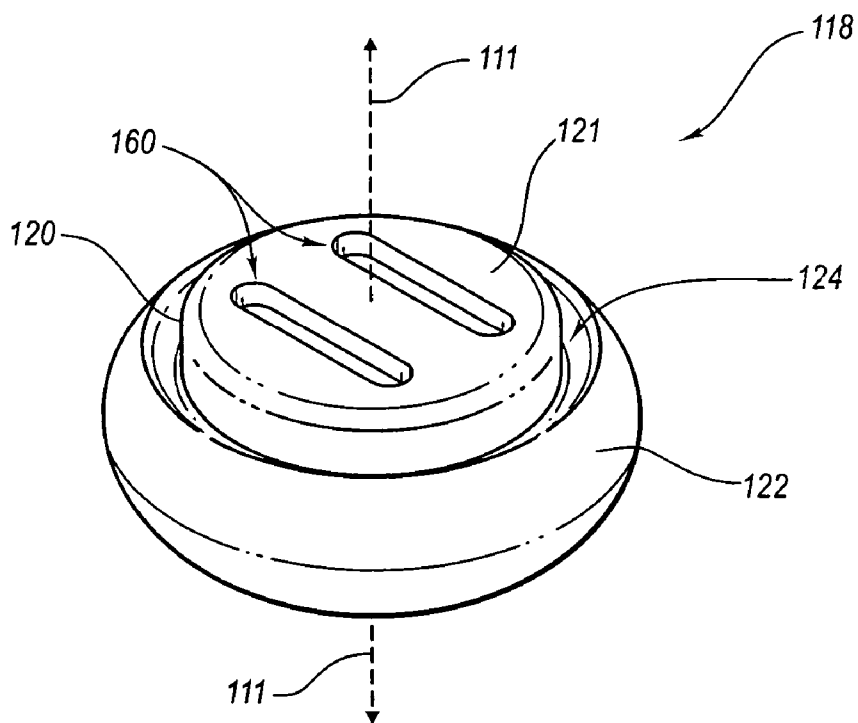

FIG. 25

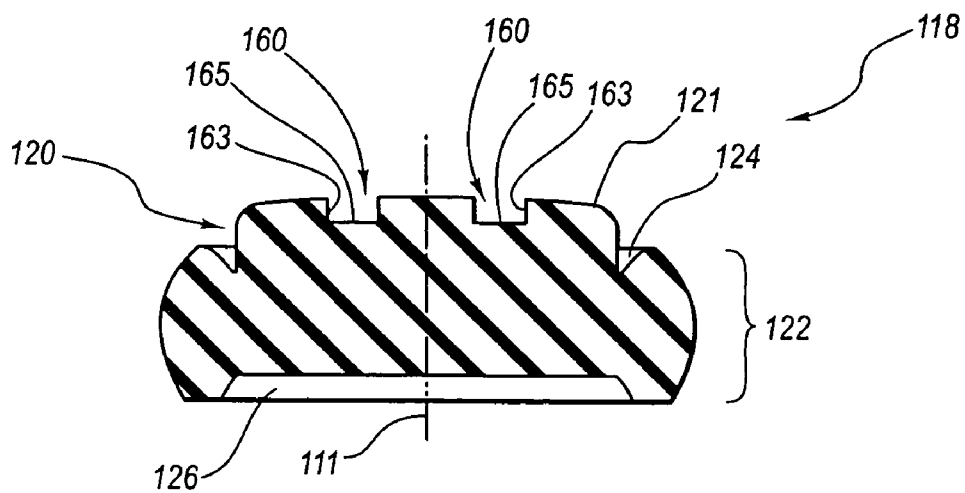

FIG. 26



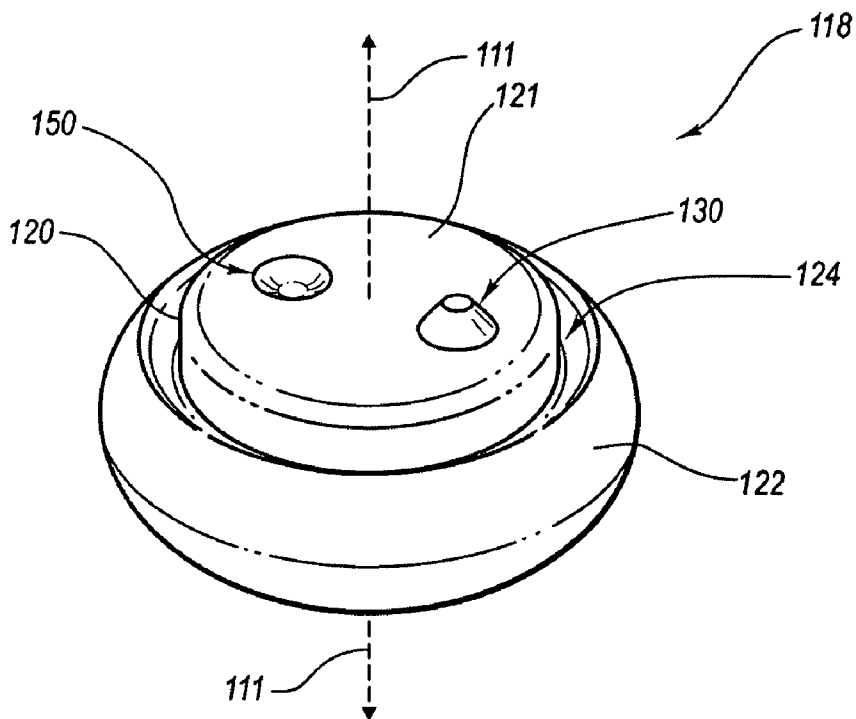

FIG. 27

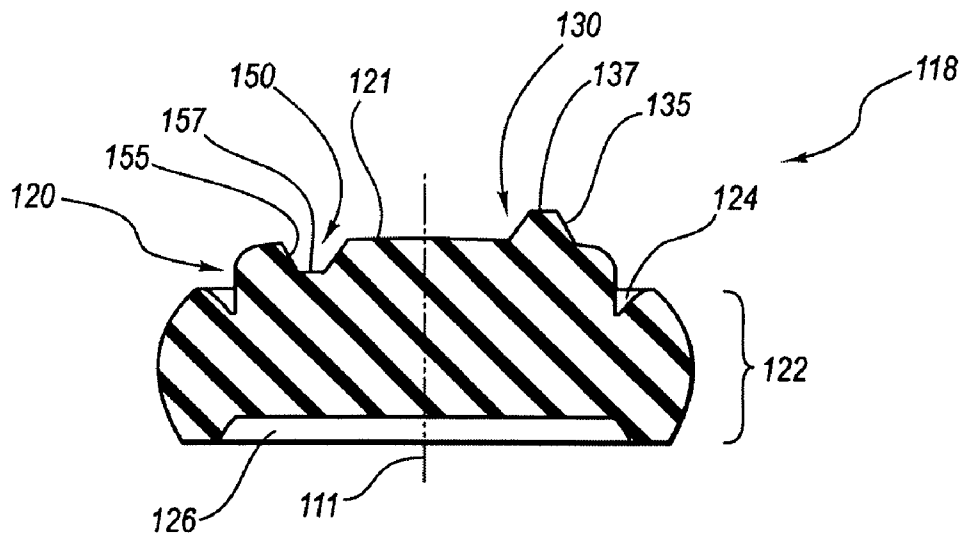
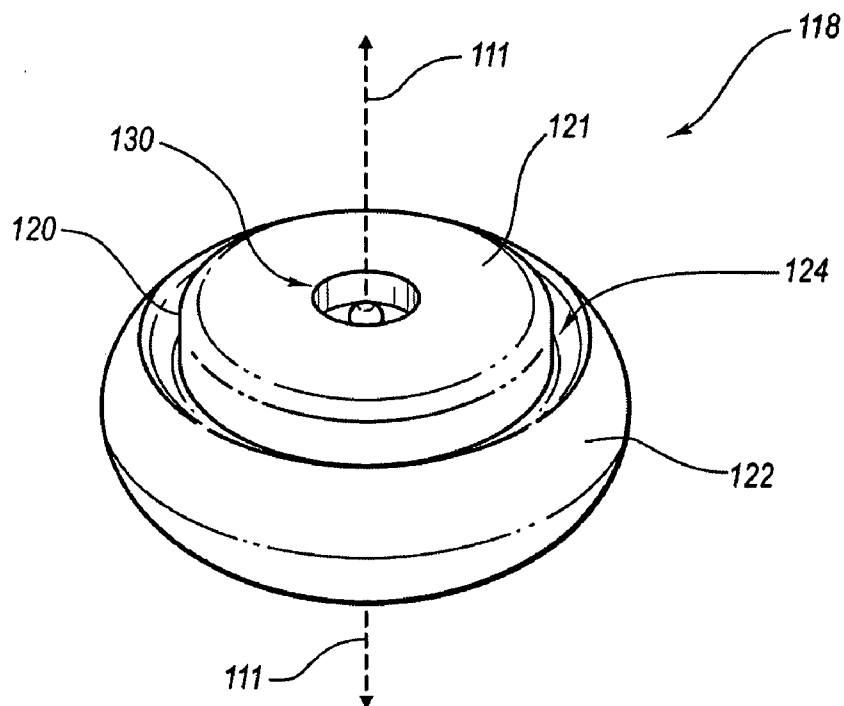
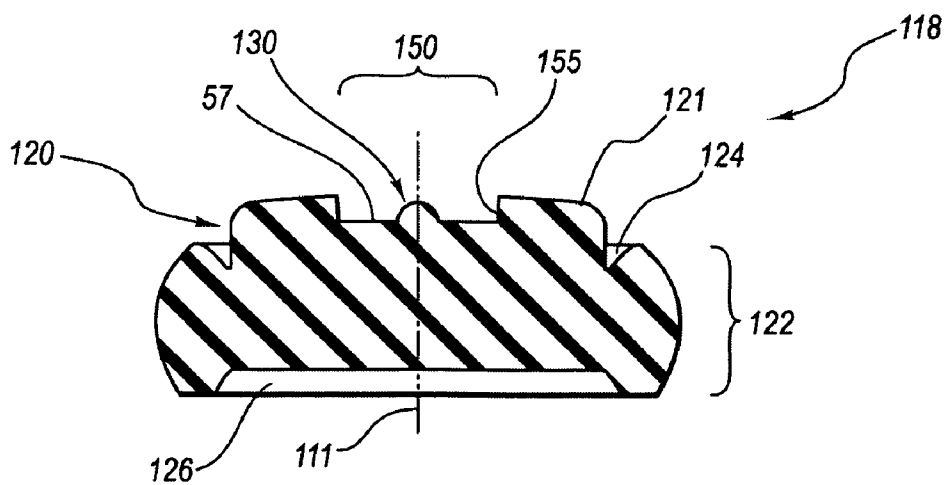

FIG. 28



**FIG. 29**



**FIG. 30**

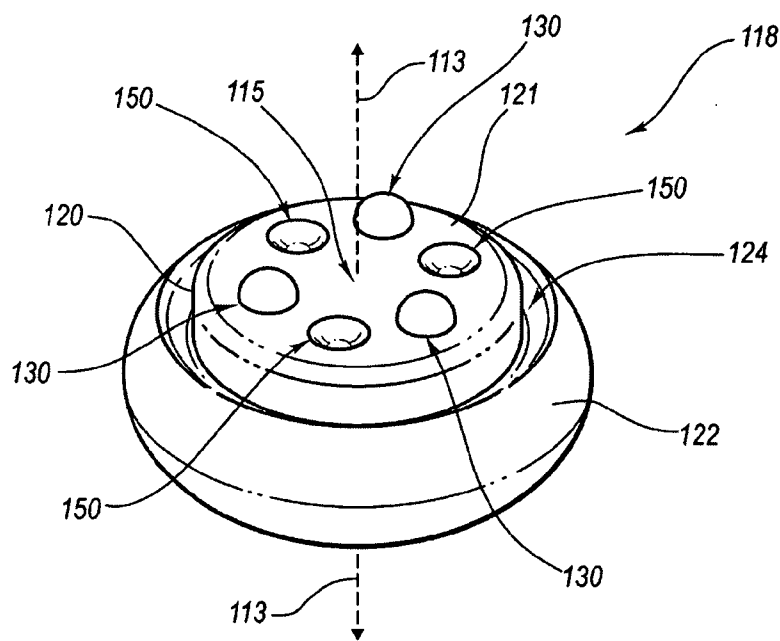

FIG. 31

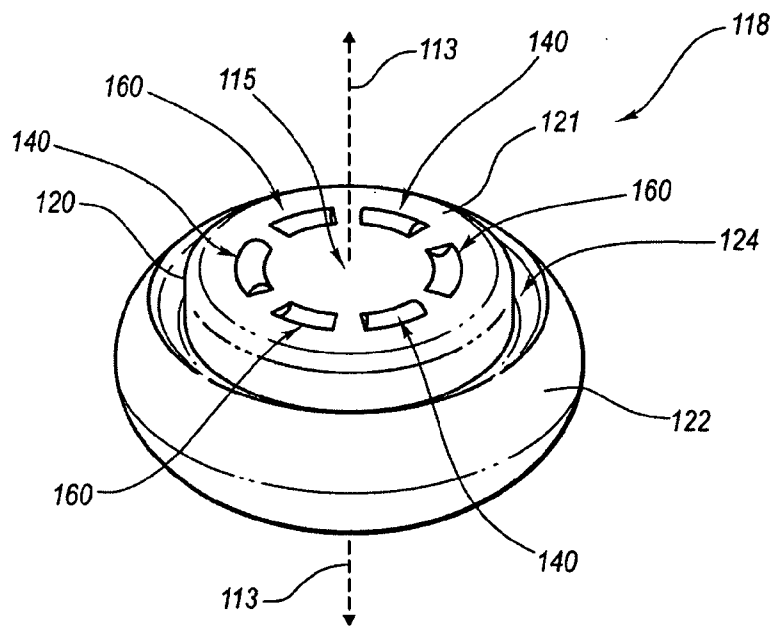

FIG. 32

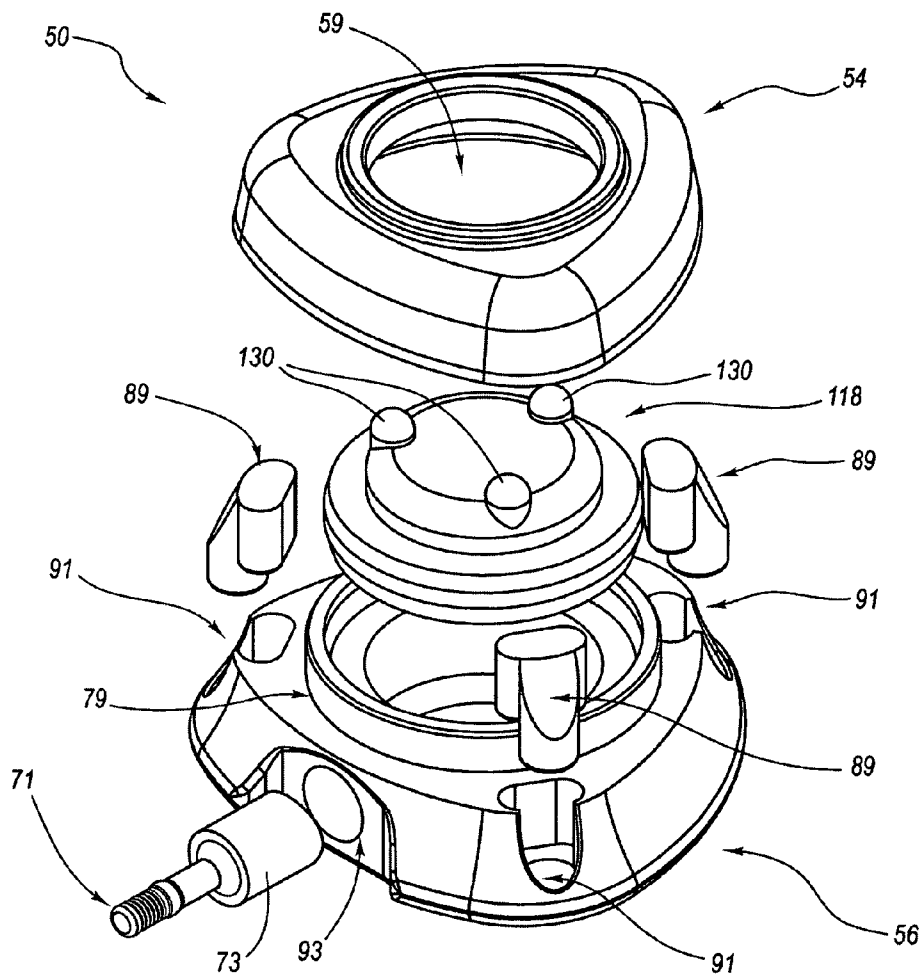
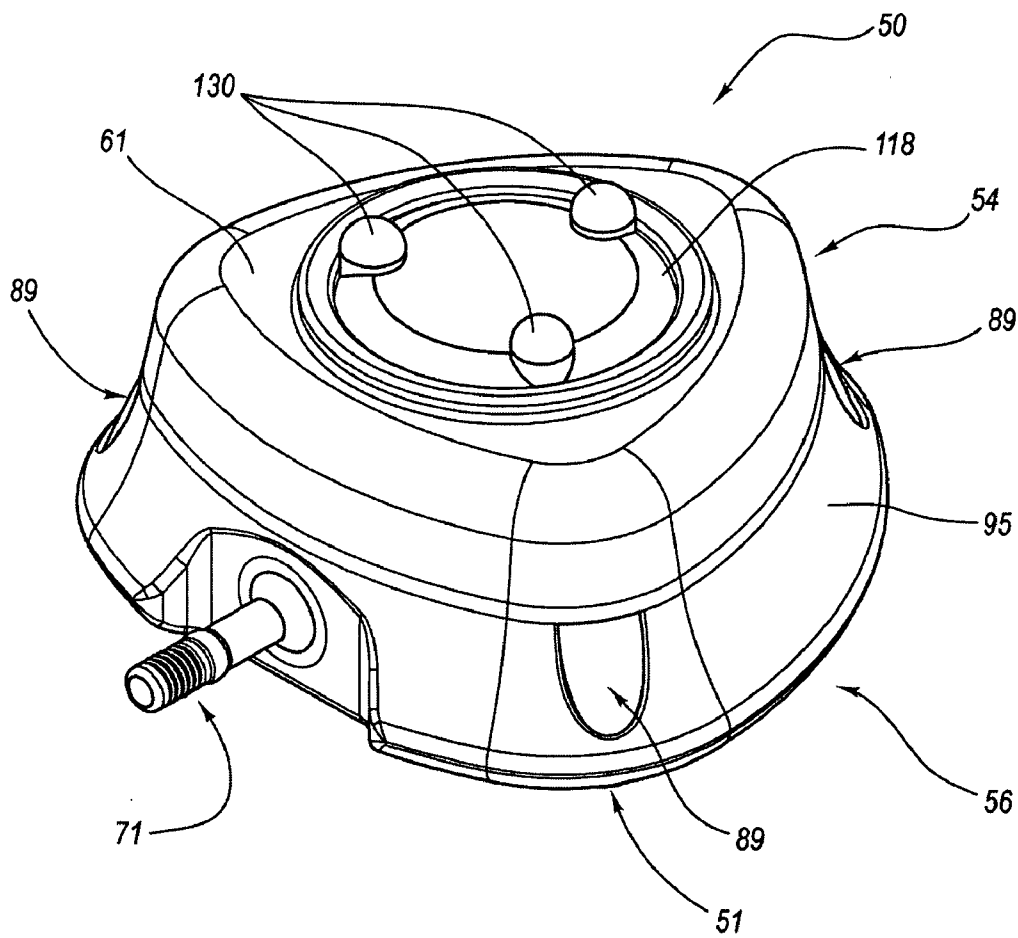

FIG. 33



**FIG. 34**

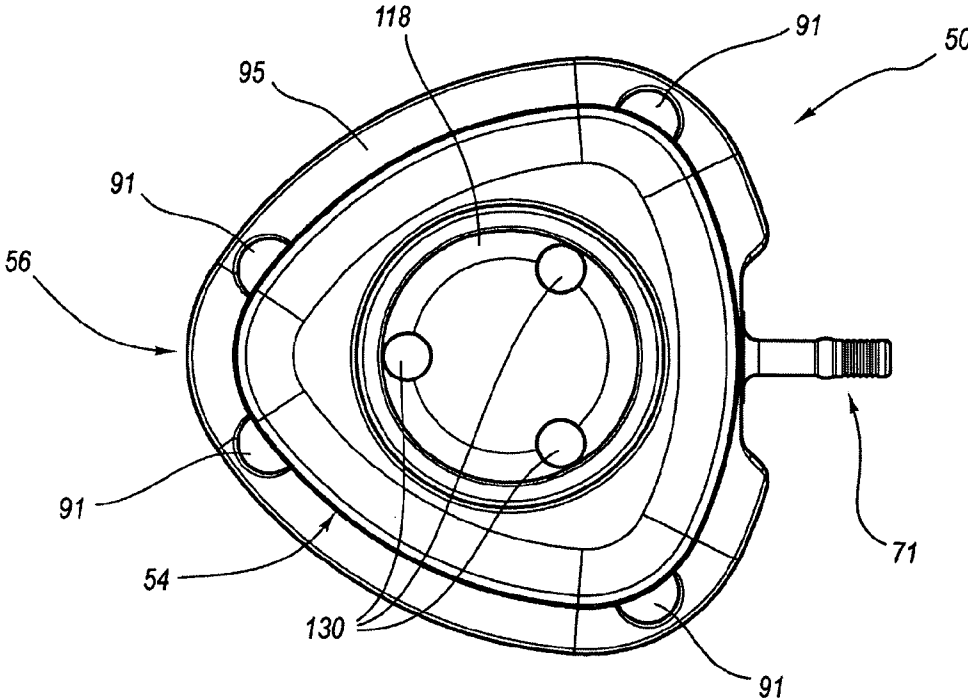

FIG. 35

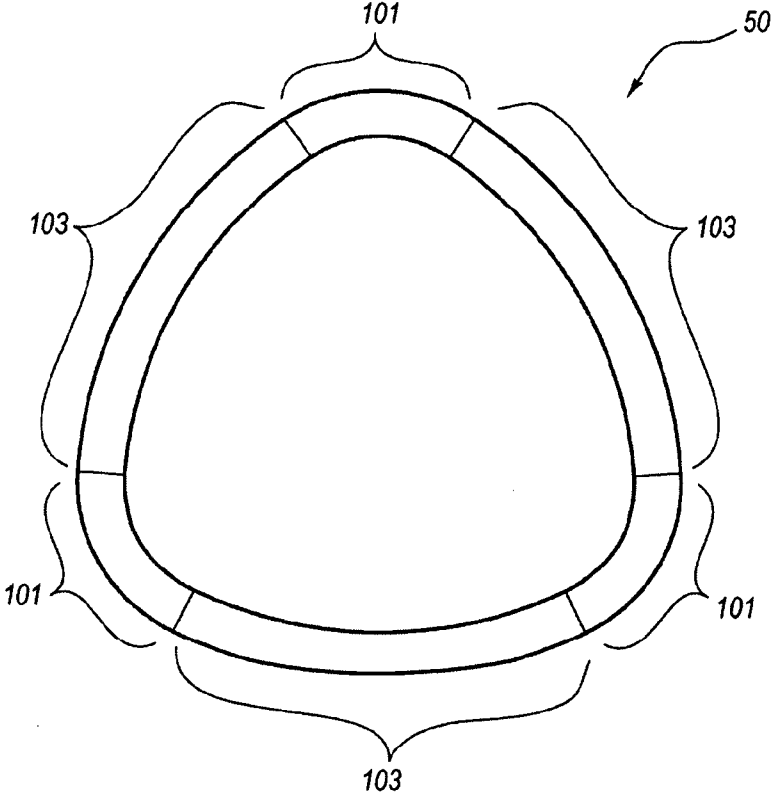

FIG. 36

**SEPTUM FEATURE FOR IDENTIFICATION OF AN ACCESS PORT**

**CROSS-REFERENCE TO RELATED APPLICATIONS**

[0001] This application is a continuation of U.S. patent application Ser. No. 13/471,219, filed May 14, 2012, now U.S. Pat. No. 8,608,713, which is a continuation of U.S. patent application Ser. No. 11/320,223, filed Dec. 28, 2005, now U.S. Pat. No. 8,177,762, which claims the benefit of priority to U.S. Provisional Patent Application No. 60/658,518, filed Mar. 4, 2005, and which is a continuation-in-part of U.S. patent application Ser. No. 10/374,000, filed Feb. 25, 2003, now U.S. Pat. No. 7,713,251, which is a continuation of U.S. patent application Ser. No. 09/582,406, filed Jun. 23, 2000, now U.S. Pat. No. 6,527,754, which is a U.S. national stage application under 35 USC §371 of International Application No. PCT/US99/28695, filed Dec. 3, 1999, which claims the benefit of priority to U.S. Provisional Patent Application No. 60/111,257, filed Dec. 7, 1998, the disclosure of each of which is incorporated, in its entirety, by this reference.

**BACKGROUND**

[0002] Access portals, or ports, provide a convenient method to repeatedly deliver medicants to remote areas of the body without utilizing surgical procedures. The port is totally implantable within the body, and permits the infusion of medications, parenteral solutions, blood products, and other fluids. The port may also be used for blood sampling

[0003] Known ports typically include a chamber accessible through a self-sealing septum. Septums of the prior art vary in shape, from a wafer-like cylindrical block of silicone to a pre-molded septum of U.S. Pat. No. 4,802,885 to Weeks et al. The pre-molded septum of U.S. Pat. No. 4,802,885 includes opposed convex surfaces and a peripheral ledge.

[0004] In common practice, a caregiver locates the septum of the port by palpation. Port access is accomplished by percutaneously inserting a needle, typically a non-coring needle, perpendicularly through the septum of the port and into the chamber. The drug or fluid is then administered by bolus injection or continuous infusion. Ordinarily the fluid flows through the chamber, into a catheter and finally to the site where the fluid is desired. Except for the septum, traditional ports are constructed from all-metal or all-plastic. Each type of construction has unique advantages and disadvantages.

[0005] All-metal constructions have the advantages that they maintain a septum in a self-sealing fashion after repeated percutaneous injections. Additionally, all-metal constructions, such as titanium, or stainless steel provide a port which is both biocompatible and compatible with the injected fluid.

[0006] However, all-metal constructions present the disadvantages that they are relatively heavy, difficult to fabricate and relatively expensive. Additionally, all-metal ports produce large Magnetic Resonance Imaging (MRI) artifacts. On the other hand, all-plastic ports have the advantages that they are inexpensive to construct, light in weight, and do not create an MRI artifact. However, ports constructed from plastic have the disadvantage that infused fluids may react with the plastic body of the port. All-plastic ports contain the disadvantage that they cannot maintain a sealing engagement with the septum after repeated percutaneous injections. Additionally, all-plastic ports are susceptible to nicks and scratches on the

interior surface by the accessing needle. These nicks and scratches could lead to nidus, blood clots, or precipitation formations.

[0007] Efforts have been made to combine the advantages of all-metal ports with all-plastic ports. For example, in U.S. Pat. No. 4,802,885 to Weeks et al., a metal reservoir having a chamber sealed by a pre-formed silicone septum is jacketed by a single piece of a silicone elastomer. However, all-metal ports jacketed by a single piece of elastomer have significant shortcomings. These shortcomings include quality control problems during manufacturing, and expensive molding processes.

[0008] Other efforts have focused on providing a multiple piece all-plastic housing in cooperation with an open metal cup to sealingly engage a septum. For example, see U.S. Pat. No. 5,213,574 to Tucker. This design has shortcomings associated with it, including defects in the plastic housing which may cause an improperly sealed septum. Once the septum is improperly sealed the entire port must be discarded.

[0009] Therefore a need has arisen for an access port device which addresses the problems of prior port devices.

[0010] A variety of implantable devices, known as subcutaneous access ports, are utilized to deliver fluids to or to withdraw fluids from the bloodstream of a patient. Such access ports typically include a needle-impenetrable housing which encloses one or more fluid cavities and defines for each such fluid cavity an access aperture communicating through the housing on the side thereof which is adjacent to the skin of the patient when the access port is implanted in the body. A needle-penetrable septum is received in and seals each access aperture. Exit passageways located in an outlet stem communicate with each of the fluid cavities for dispensing medication therefrom to a predetermined location in the body of the patient through an implanted catheter attached to the access port.

[0011] Once the access port and the catheter have been implanted beneath the skin of a patient, quantities of medication or blood may be dispensed from one such fluid cavity by means of a non-coring needle passed through the skin of the patient and penetrating the septum into one of the respective fluid cavities. This medication is directed through the distal end of the catheter to an entry point into the venous system of the body of the patient.

[0012] Blood may also be withdrawn for sampling from the body of a patient through such an access port. This is accomplished by piercing the skin of the patient and one of the respective septums with a non-coring needle and applying negative pressure thereto. This causes blood to be drawn through the catheter into the fluid cavity corresponding to the pierced septum and then out of the body of the patient through the needle.

[0013] To prevent clotting thereafter, the withdrawal route is flushed with a saline solution or heparin using again a non-coring needle piercing the skin of the patient and the septum in the same manner as if a medication were being infused.

[0014] Both intermittent and continual injections of medication may be dispensed by the access port. Continual access involves the use of a non-coring needle attached to an ambulatory pump or a gravity feed IV bag suspended above the patient. The ambulatory-type pump or the IV bag continually feeds the medication or fluid through the needle to the fluid cavity in the access port and from there through the catheter to the entry point into the venous system.

**[0015]** To facilitate locating each respective septum once the access port has been implanted, some access ports incorporate a raised circular ring located about the outer perimeter of the septum. This raised ring enhances the tactile sensation afforded by the subcutaneous septum to the palpating fingertip of a medical practitioner. Alternatively, other access ports have utilized palpation ridges rather than a raised circular ring for substantially the same purpose. The palpation ridges allow the location of the septum to be accurately determined when the access port is subcutaneously implanted.

**[0016]** To preclude reaction with the tissues in the body of the patient, access ports are constructed of nonreactive materials, such as titanium or stainless steel. Although these materials are nonreactive, access ports constructed utilizing titanium or stainless steel materials produce an interfering or blurred image of the body of the patient in the vicinity of the implanted access port when diagnostic imaging techniques such as magnetic resonance imaging ("MRI"), CAT scans, or computerized tomography are used. The blurred region caused by the presence of a metallic access port in the body of a patient extends beyond the access port itself. Therefore, the use of metallic access ports limits the diagnostic imaging techniques that may be used relative to those areas of the body in which an access port is implanted. In place of metallic materials some access ports have been fabricated at least in part from biocompatible plastics.

**[0017]** A further problem relating to the materials for and manufacture of access ports is the deleterious impact of some manufacturing procedures on the fluids which flow through the fluid cavities and related structures located between the fluid cavities and the catheter. During the manufacture of an access port, whether the port is comprised of metallic or plastic materials, it becomes necessary to form the fluid cavities and exit passageways through which the fluid will be directed into the attached catheter. This manufacturing process often leaves sharp edges, seams and corners in the areas where the fluid cavity is to direct the flow of the fluid through an exit passageway. As blood or other fluids are injected through the septum into the fluid cavity, pressure developed within the fluid cavity tends to cause fluid to flow through the exit passageway. As the fluid in the fluid cavity flows past the sharp edges and corners produced in the manufacture of the access port, turbulence arises, taking the form of a vortex, adjacent to the sharp edges and corners. Some fluids, such as blood, are sensitive to this turbulence, and lysing of the red blood cell component of the injected blood can occur in these turbulent areas.

**[0018]** In addition, the production of the circular fluid cavities often results in the creation of areas within the housing in which fluid flow is retarded. These areas are referred to as dead spaces and usually occur in areas of transition, such as where the bottom of the septum interfaces with the walls of the fluid cavity and where the floor of the fluid cavity meets the exit passageway through which the fluid must flow. As the flow of fluids through dead spaces is retarded, stagnation occurs, resulting in some fluid being trapped within these dead spaces. If the access port is used to withdraw or transfuse blood, blood trapped in these dead spaces may form clots and block the flow of fluid through the fluid cavity.

**[0019]** Moreover, in some prior vascular access ports the internal reservoirs are formed by two plastic parts with are bonded together. This results in an undesirable seam being formed where the adjacent parts abut one another. The inside of the reservoir should be as smooth as possible to help

prevent damage to blood cells or the initiation of blood clotting during infusion or withdrawal of blood through the port.

**[0020]** A further problem encountered in the design and construction of access port relates to the positioning of the septums within the housing of the access port. The positioning of the septums within the housing is a compromise between two conflicting objectives. These are the need to separate the septums to such a distance so that the septums may be easily differentiated for the purpose of injection and the need to restrict the overall dimensions of the access port for patient comfort and aesthetics. The distancing of the septums to facilitate their differentiation, however, results in a corresponding distancing of the fluid cavities. This result is at odds with another structural requirement for access ports with plural cavities, namely that the exit passageways from each fluid cavity be closely spaced at the point where the implanted catheter is to be coupled to the access port.

**[0021]** To guide the flow of a fluid from each of the spatially separated fluid cavities into the side-by-side configuration of fluid outflow necessitated by the dimensions of a plural lumen catheter, intermediate structural members have been required. Naturally, this complicates the process of manufacture and increases its cost, as well as the changes of structural failure.

**[0022]** There are several examples of such intermediate members used to resolve the manufacturing constraints imposed upon the construction of a passageway flowing from spatially separate fluid cavities into a side-by-side configuration acceptable by a catheter. One is to produce passageways in the form of bent metal tubes which are then insert molded or welded into the larger body of the access port. The use of such a metal component will interfere with the production of an access port which is free of limits as to the diagnostic imaging techniques that may be used relative to those areas of the body in which an access port is implanted. In addition, the integral nature of such metal outlet passageways raises the possibility of leakage of medication through the interstices between the metal tubes and the body of the access port.

**[0023]** Alternatively, to produce fluid flow from spatially separated fluid cavities into the closely spaced lumens of a catheter, each fluid cavity has been designated with its own spatially separated outlet stem. These outlet stems are then coupled by a hub structure for permanent attachment to the closely spaced lumens of a catheter. This type of arrangement increases the size of the overall access port and its cost of manufacture by adding thereto the necessity of fabricating and assembling of the hub element. Port connections to catheters in this manner are permanent. Accordingly, if the catheter is to be shortened by trimming, that trimming must occur at the distal end of the catheter, and this precludes the use of any type of specially designed tip or valve.

**[0024]** An additional set of problems encountered in the use of access ports relates to the actual connection of the catheter to the access port. This is most commonly effected by securing the catheter to an outlet stem protruding from the housing of the access port. In an attempt to lock the catheter to the outlet stem of the access port, thread-type systems have been developed wherein the catheter is attached to an outlet stem, and the outlet stem is then threaded into the access port. When utilizing this system, however, it is difficult to determine the amount of engagement of the catheter onto the outlet stem. Some catheter connection systems do not allow visual verification of attachment. As a result, leakage and failure can occur.



**[0025]** To overcome this problem, access ports are produced in which the catheter is pre-attached at the factory. While this practice alleviates many of the problems with leakage and failure due to catheter slippage, this system severely limits the type of the catheter usable with the access port. This precludes the use of catheters having specialized distal tips, as the distal end of the catheter is the only end that can then be trimmed to effect its ultimate sizing. For example, catheters utilizing a Groshong® slit valve at their distal end may not have any of the distal tip of the catheter removed without compromising the catheter.

**[0026]** Thus, there has been a need for an improved vascular access port which overcomes the above-noted problems, and which can be manufactured economically. The present invention fulfills these needs and provides other related advantages.

#### SUMMARY

**[0027]** One aspect of the instant disclosure relates to access port for providing subcutaneous access to a patient. More particularly, an access port may comprise a body configured for capturing a septum for repeatedly inserting a needle therethrough into a cavity defined within the body. Further, the septum may include at least one topographical feature configured for identification of the septum. Also, a septum for an access port for providing subcutaneous access to a patient is encompassed by the instant disclosure, wherein the septum may comprise a body exhibiting at least one topographical feature configured for identification of the septum.

**[0028]** A further aspect of the instant disclosure relates to an access port for providing subcutaneous access to a patient including a body configured for capturing a septum for repeatedly inserting a needle therethrough into a cavity defined within the body, and a means for identification of the septum. In one embodiment, the means for identification may comprise at least one topographical feature of a surface of the septum. In another embodiment, means for identification may comprise a visually perceivable feature selected from the group consisting of: a color, a symbol, a letter, a pattern, and indicia. In a further embodiment, means for identification may comprise an x-ray detectable feature or an ultrasound detectable feature. In yet an additional embodiment, means for identification may comprise an RFID tag.

**[0029]** Another aspect of the instant disclosure relates to a method of identifying a subcutaneously implanted access port. More particularly, an access port including a septum may be provided. Further, at least one topographical feature of the septum of the access port may be perceived. In addition, the subcutaneously implanted access port may be identified in response to perceiving the at least one feature of the septum of the access port.

**[0030]** Features from any of the above mentioned embodiments may be used in combination with one another in accordance with the instant disclosure. In addition, other features and advantages of the instant disclosure will become apparent to those of ordinary skill in the art through consideration of the ensuing description, the accompanying drawings, and the appended claims.

#### BRIEF DESCRIPTION OF THE DRAWINGS

**[0031]** Advantages of the instant disclosure will become apparent upon review of the following detailed description

and drawings, which illustrate representations (not necessarily drawn to scale) of various aspects of the instant disclosure, wherein:

**[0032]** FIGS. 1A-1D depict various views of the preferred dual-port implantable access device of the present invention;

**[0033]** FIGS. 2A-2E depict various views of the preferred single-port implantable access device of the present invention;

**[0034]** FIG. 3A-3D depict various views of another embodiment of the implantable access device of the present invention;

**[0035]** FIG. 4 depicts an alternative embodiment of the cup member of FIGS. 1-3;

**[0036]** FIGS. 5A and 5B depict views of another alternative embodiment of the cup member of FIGS. 1-3;

**[0037]** FIG. 6 shows a schematic, side cross-sectional view of a subcutaneously implanted access port;

**[0038]** FIGS. 7 and 8 show a perspective view and a schematic side view, respectively, of a septum including a protrusion;

**[0039]** FIGS. 9 and 10 show a perspective view and a schematic side view, respectively, of a septum including a plurality of protrusions;

**[0040]** FIGS. 11 and 12 show a perspective view and a schematic side view, respectively, of another embodiment of a septum including a plurality of protrusions;

**[0041]** FIGS. 13 and 14 show a perspective view and a schematic side view, respectively, of a further embodiment of a septum including a plurality of protrusions;

**[0042]** FIGS. 15 and 16 show a perspective view and a schematic side view, respectively, of yet an additional embodiment of a septum including a plurality of protrusions;

**[0043]** FIGS. 17 and 18 show a perspective view and a schematic side view, respectively, of a septum including a plurality of elongated protrusions;

**[0044]** FIGS. 19 and 20 show a perspective view and a schematic side view, respectively, of another embodiment of a septum including a plurality of elongated protrusions;

**[0045]** FIGS. 21 and 22 show a perspective view and a schematic side view, respectively, of a septum including a recess;

**[0046]** FIGS. 23 and 24 show a perspective view and a schematic side cross-sectional view, respectively, of a septum including a plurality of recesses;

**[0047]** FIGS. 25 and 26 show a perspective view and a schematic side cross-sectional view, respectively, of a septum including a plurality of elongated recesses;

**[0048]** FIGS. 27 and 28 show a perspective view and a schematic side cross-sectional view, respectively, of a septum including a recess and a protrusion;

**[0049]** FIGS. 29 and 30 show a perspective view and a schematic side cross-sectional view, respectively, of a septum including a recess and a protrusion, wherein the protrusion is positioned generally within the recess;

**[0050]** FIG. 31 shows a perspective view of a septum including a plurality of protrusions and a plurality of recesses positioned about a center of revolution;

**[0051]** FIG. 32 shows a perspective view of a septum including a plurality of elongated protrusions and a plurality of elongated recesses;

**[0052]** FIG. 33 shows an exploded assembly view of one embodiment of an access port according to the instant disclosure;

[0053] FIG. 34 shows a perspective view of the assembled access port shown in FIG. 33;

[0054] FIG. 35 shows a top elevation view of the assembled access port shown in FIG. 34; and

[0055] FIG. 36 shows a simplified representation of a transverse cross section of the access port shown in FIGS. 33-35.

#### DETAILED DESCRIPTION

[0056] FIGS. 1A-1D depict various views of the preferred dual-port implantable access device 10 of the present invention. The port 10 generally comprises a housing member 12 defining fluid chambers 22A and 22B. The chambers are sealed by the housing 12, bottom cup members 14A and 14B, and self-sealing septum members 16A and 16B. In this embodiment, the housing 12 is preferably formed of titanium, stainless steel, ceramic, and/or other biocompatible material. The septum 16A and 16B is preferably formed of silicon or other semi-permeable materials that permit ingress and egress of needles to deliver fluid to the chambers 22A and/or 22B. An exit port 18 is provided in communication with chambers 22A and 22B, which delivers fluid out of the chambers 22A and/or 22B to a predetermined location, via stem 20 and attached catheter (not shown), as is understood in the art.

[0057] The septums 16 are formed with a generally circular shape, and, as shown in the drawings, may include a nipple 26 or a concave portion 28 on the outer surface thereof. The nipple is advantageous for visual and/or tactile location of the port device 10, and as a locator for needle insertion. Likewise, concave portion 28 provides similar features, but may be used in areas where a protruding nipple is undesirable. The septums 16A and 16B and housing 12 are preferably formed with mated tongue and groove portions, as shown in the side view drawings of FIGS. 1A and 1C. The housing may further include molded top member 24 which press against the septum for further stability.

[0058] As opposed to plastic materials used in the prior art, the cup portion 14 is preferably formed of titanium or stainless steel to resist scratches and/or debris from being introduced into the chambers, as a result of needle impacts thereon. Preferably, cup 14A and 14B is attached to housing 12 via insert molding, interference fit, ultrasonic weld, biocompatible glue, and/or other attachment means. FIGS. 2A-2E depict a single-port version of the port device of the present invention, and is similarly constructed as shown in FIGS. 1A-1D.

[0059] FIG. 3A-3D depict another embodiment of the port device of the present invention. In this embodiment, the cup member 14' includes sidewall portions 28 that are dimensioned to fit within the chamber 22', defined by housing 12'. The cup member 14' is attached to the housing 12' by insert molding, interference fit, ultrasonic weld, biocompatible glue, or other attachment means known in the art. The septum 16' is similar to the septum 16A and/or 16B and may also include a nipple or concave portion, described above. In this embodiment, a metal ring 30 is provided which circumscribes the top of the housing 12' and is positioned above the septum 16'. The ring 30 preferably includes flange members 32, which have an upper surface dimensioned so as to urge a needle downward toward the septum, thus preventing errant entry of needles within the septum. In this embodiment the ring structure is formed of titanium, stainless steel or ceramic material for increase mechanical resistance to puncture and/or tear. Accordingly, since the ring member 30 will protect the other components, the housing can be formed of less expen-

sive material, e.g., plastics, etc. The ring member 30 and housing 12' preferably include mated tongue and groove portions to hold the ring member securely against the housing, as shown. Additionally, the lower surface of the flange members 32 are dimensioned so as to force against the septum, thereby holding the septum in place.

[0060] FIGS. 4 and 5A-5B depict alternative embodiments for the cup member described above in FIGS. 1-3. In the embodiment of FIG. 4, the cup member 14" defines an exit port 18' therein, and preferably located at the bottom portion of the cup 14", as shown. A stem 20' is connected to the port 18' at one end, and a catheter 36 is connected to the other end of the stem 20'. So as to provide a low-profile shape, it is preferred that the stem 20' includes an elbow, or angled portion, to direct fluid sideways away from the port, as shown. In FIGS. 5A and 5B, the cup 14' is formed with a flange 40 to define an opening 38 that is dimensioned to accept a stem 20" therein. The cup 14" and/or 14' are provided to better anatomically fit into the subcutaneous areas around muscle tissue, and each are connected to the housing (not shown) in a manner similar to the embodiments of FIG. 1, 2 or 3.

[0061] As discussed above, access ports may provide percutaneous access to a patient. In further detail, referring to FIG. 6 shows a schematic, side cross-sectional view of another embodiment of an access port 50, which is implanted within a patient. In further detail, access port 50 includes a housing or body 60 defined by a cap 54 and a base 56. Cap 54 and base 56, as known in the art, may be configured for capturing therebetween a septum 118. As shown in FIG. 6, cap 54 and base 56 may matingly engage one another along a mating line 55. Cap 54 and base 56 may be secured or affixed to one another via mechanical fasteners such as screws or other fastening devices, may be adhesively affixed to one another, or may be affixed to one another as known in the art. Further, cap 54, base 56, and septum 118 may collectively define a cavity 66 in fluid communication with a lumen of outlet stem 71. As shown in FIG. 6, the body 60 of access port 50 may be implanted in a patient 67 to position the cavity 66 subcutaneously within the patient 67. As known in the art, sutures (may be used to affix the access port 50 within the patient 67, if desired. After the body 60 is implanted in a patient 67, the upper surface of the septum 118 may be generally flush or aligned with the surface of the skin surface 76 of the patient 67 and may be repeatedly punctured for creating a percutaneous passageway from the exterior of the skin of the patient into the cavity 66. The outlet stem 71 may create a fluid-communicative passageway from the cavity 66 through the outlet stem 71 and into the interior of the patient 67. As mentioned above, a catheter may be coupled to the outlet stem 71 for fluid communication with the cavity 66 and for transferring fluid to a desired remote location from the cavity 66 and within a patient 67. Body 60 of access port 50 may comprise a biocompatible material such as polysulfone, titanium, or any other suitably biocompatible material as known in the art. Thus, generally, the body 60 may be formed from a biocompatible plastic material. Body 60 may include a concave bottom or, in another embodiment, may include a flat bottom, without limitation. Also, as mentioned above, access port 50 may comprise a so-called single port or a multiple port (e.g., dual port, triple port, etc.) configuration, without limitation.

[0062] One aspect of the instant disclosure contemplates that a septum of an access port may include at least one perceivable or identifiable feature for identifying the septum

and, optionally, the access port. Of course, the identifiable feature may be perceivable after the access port is implanted within a patient. For example, at least one or perhaps multiple identifiable feature(s) of a septum of an access port may be correlative to information (e.g., a manufacturer's model or design) pertaining to the access port. Thus, an identifiable feature from an access port of a particular model may be unique in relation to most, if not all, other identifiable features of another access port of a different model or design. Of course, the at least one identifiable feature of an access port may be further correlative with any information of interest, such as type of port (e.g., power-injectable port), catheter type, date of manufacture, material lots, part numbers, etc. In this way, once at least one identifiable feature of an access port is observed or otherwise determined, correlation of such at least one feature of an access port may be accomplished, and information pertaining to the access port may be obtained. Accordingly, "identification," as used herein and in connection with a septum, means to provide the ability to correlate selected information of interest with a perceivable feature of a septum.

[0063] In one embodiment, at least one feature may be perceived by palpation (i.e., to examine by touch), by way of other physical interaction, or by visual observation. Accordingly, a person may touch or feel the septum of the access port to perceive at least one identifying characteristic of the septum. In another embodiment, at least one identifiable feature may be perceived via x-ray or ultrasound imaging. In yet a further embodiment, at least one identifiable feature may be perceived through magnetic, light, or radio energy interaction or communication with the septum.

[0064] Turning to the embodiment wherein at least one feature may be perceived through palpation, other physical interaction, or visual observation, a topography or exterior surface feature of a septum of an access port may be configured for perception. For example, the instant disclosure contemplates that a septum may include at least one topographical feature configured for identifying the access port after it is implanted. More particularly, FIGS. 7 and 8 show a perspective view and a schematic side view, respectively, of a septum 118 including at least one topographical feature. Generally, septum 118 may include a base region 122 and an elevated region 120 extending from the base region 122 and including a septum surface 121. As noted in the art, septum 118 may be structured for assembly within the housing, wherein the housing causes at least a portion of the septum 118 to be compressed. Such compression may facilitate sealing of a puncture or aperture, which is, formed between septum surface 121 and septum surface 109. FIGS. 7 and 8 show one embodiment of septum 118, which includes an annular recess 124 extending circumferentially about raised region 120 as well as a recess 126 that is formed into base region 122. Further, as shown in FIGS. 7 and 8, septum 118 may be substantially symmetric about central access 111. Such a configuration may facilitate substantially uniform compression within at least a portion of base region 122 when a periphery of base region 122 is compressed. Additionally, a protrusion 130 may extend from septum surface 121 and may be configured for identifying septum 118 (and, optionally, an access port with which septum 118 is assembled). Accordingly, protrusion 130 may have a selected size and shape that allows for perception through palpation. As shown in FIGS. 7 and 8, protrusion 130 may, optionally, include a generally rounded end 131. Such a configuration may provide a protrusion struc-

ture for identification of septum 118, which is relatively robust and resists damage in response to repeated physical interactions, such as, palpation. Of course, protrusion 130 may exhibit various selected characteristics, such as, for example, fillets, chamfers, concave surfaces, convex surfaces, through-holes, cavities, grooves, or other geometric features as may be desired.

[0065] The instant disclosure further contemplates that a septum may include a plurality of protrusions that, collectively, are structured for perception and identification of the septum. For example, FIGS. 9 and 10 show a perspective view and a schematic side view, respectively, of a septum 118 including three protrusions 130. Septum 118, as shown in FIGS. 9 and 10, may be generally configured as described above with respect to FIGS. 6 and 7. However, as shown in FIGS. 9 and 10, septum 118 may include protrusions 130, which are substantially identical. Further, optionally, protrusions 130 may be positioned substantially equidistantly from central access 111, as shown in FIGS. 9 and 10. Such a configuration may allow for perception of protrusion 130, identification of the septum 118 in response to perception of protrusions 130, and may also allow for an indication of the position of central access 111 (i.e., a center of septum surface 121). As shown in FIGS. 9 and 10, each of protrusions 130 may include a generally rounded end 131. In other embodiments, each of protrusions 130 may have an end that is configured as desired (e.g., similarly, substantially identically, or differently), without limitation. Moreover, it may be appreciated that protrusions 130 may embody various selected positions, sizes, or configurations upon a septum for perception and identification of such a septum. For example, FIGS. 11 and 12 show a perspective view and a schematic side view, respectively, of another embodiment of a septum 118 including three protrusions 130 that are larger than the protrusions 130 shown in FIGS. 9 and 10. As shown in FIGS. 11 and 12, protrusions 130 may be substantially equidistantly positioned about central access 111 and each of protrusions 130 may include a generally rounded end 131 (e.g., at least partially spherical, generally convex, or generally ovate).

[0066] As mentioned above, the instant disclosure contemplates that a septum may include at least one protrusion and that the protrusion may be configured, as desired, for perception and identification of the septum. For example, a protrusion extending from a surface of a septum may include at least one substantially planar surface. FIGS. 13 and 14 show a perspective view and a schematic side view, respectively, of a septum 118 including protrusions 130, each of which includes a substantially planar surface or substantially planar end 133. Otherwise, septum 118, as shown in FIGS. 13 and 14, may be configured generally as described above with respect to FIGS. 9 and 10. As shown in FIGS. 13 and 14, protrusions 130 may be generally cylindrical as they extend from septum surface 121. Of course, in other embodiments, protrusions 130 may taper as they extend from septum surface 121. In addition, the cross-sectional shape of protrusions 130 (taken transverse to the direction of extension from septum surface 121) may be generally circular, generally rectangular, generally triangular, generally oval, or generally polygonal, without limitation. Of course, the size of each of protrusions 130 may be selected for providing an identifiable topography to septum 118. For example, in another embodiment, FIGS. 15 and 16 show a perspective view and a schematic side view, respectively, of a septum 118, which is generally configured as described above with reference to FIGS. 13 and 14, but

includes protrusions **130** that are larger than the protrusions **130** as shown in FIGS. **13** and **14**. Such a configuration may be perceivably different (e.g., by palpation) from the embodiment of septum **118** as shown in FIGS. **13** and **14**.

[0067] As mentioned above, at least protrusion of a septum may be sized, shaped, and structured as desired. For example, in another embodiment, a septum may include at least one protrusion that is elongated. For example, FIGS. **17** and **18** show a perspective view and a schematic side view, respectively, of a septum **118** including elongated protrusions **140**. As shown in FIGS. **17** and **18**, elongated protrusions **140** may each extend between a lateral end **142** and a lateral end **144**, generally along a linear (i.e., straight) path. Of course, in other embodiments, elongated protrusions **140** may extend along respective arcuate paths between each of lateral ends **142** and **144**, respectively. Furthermore, at least one elongated protrusion may form a pattern (e.g., spiral, substantially concentric rings, substantially parallel lines, intersecting lines, etc.). As shown in FIGS. **17** and **18**, elongated protrusions **140** may extend up on septum surface **121** along substantially parallel paths. Further, elongated protrusions **140** may be substantially equidistantly positioned with respect to central access **111**. As shown in FIGS. **17** and **18**, each of the elongated protrusions **140** may exhibit a generally rounded boundary surface **141**, as shown in FIG. **18**. Of course, the instant disclosure contemplates that at least one elongated protrusion may embody various sizes, shapes, and configurations. For example, FIGS. **19** and **20** show a perspective view and a schematic side view of a septum **118** including elongated protrusions **140**, each of which includes a substantially planar surface or substantially planar end **143**. Thus, it may be appreciated that such a septum **118** may be perceivably distinguished from the septum **118** as shown in FIGS. **17** and **18**.

[0068] In a further aspect of the instant disclosure, a septum may include at least one recess that is structured for perception and identification of the septum. For example, FIGS. **21** and **22** show a perspective view and a schematic side cross-sectional view (taken through recess **150**), respectively, of a septum **118** including a recess **150**. As shown in FIGS. **21** and **22**, recess **150** is defined by an arcuate surface **151**, which is formed into septum surface **121**. Also, recess **150** may be generally aligned with central access **111**, if desired. Such a configuration may provide a perceivable feature for identifying septum **118**. Of course, surface **151** may comprise a plurality of substantially planar surfaces or at least one arcuate surface (e.g., partially spherical, partially cylindrical, generally ovate, or any other arcuate surface known in the art). In addition, a periphery of recess **150** may be generally circular, as shown in FIGS. **21** and **22**, or it may exhibit another selected shape. For example, without limitation, a periphery of a recess formed into a septum may be substantially oval, substantially rectangular, generally polygonal, star-shaped, or as otherwise may be desired.

[0069] In another embodiment, a septum may include a plurality of recesses configured for perception (e.g., visual or by palpation) and identification of the septum. For example, FIGS. **23** and **24** show a perspective view and a schematic side cross-sectional view (taken through each of recesses **150**) of a septum **118** including recesses **150**. As shown in FIGS. **23** and **24**, each of recesses **150** may be defined by an arcuate side surface **153** and a substantially planar interior surface **155**. Further, each of recesses **150** may be positioned substantially equidistantly from central access **111** and may also be sub-

stantially equally circumferentially spaces from one another. Each of recesses **150** may have a selected depth into septum surface **121**. For example, as shown in FIGS. **23** and **24**, each of recesses **140** may exhibit a substantially equal depth. In other embodiments, at least one of recesses **150** may exhibit a depth that is different from at least another of recesses **150**. In a further embodiment, each of recesses **150** may exhibit a different depth. Similarly, as shown in FIGS. **23** and **24**, each of recesses **150** may be substantially identical. In other embodiments, one or more of recesses **150** may be configured differently than at least another of recesses **150**.

[0070] The instant disclosure also contemplates that at least one recess formed in a septum may comprise of at least one elongated recess. Thus, the instant disclosure contemplates that a septum may include at least one elongated recess configured for identifying the septum, an access part in which the septum is assembled, or both. For example, FIGS. **25** and **26** show a perspective view and a schematic side cross-sectional view (taken through elongated recesses **160**), respectively, of a septum **118** including elongated recesses **160**. Generally, each of elongated recesses **160** may extend along septum surface **121** along a selected path. For example, as shown in FIGS. **25** and **26**, each of elongated recesses **160** may extend along a substantially linear or straight path. Optionally, as shown in FIGS. **25** and **26**, the paths along which each of elongated recesses **160** follows may be substantially parallel to one another. Of course, in other embodiments, elongated recesses may be arcuate, non-parallel, or may at least partially intersect with one another. As shown in FIGS. **25** and **26**, elongated recesses **160** may be positioned substantially equidistantly from central access **111**. As discussed above in relation to elongated protrusions, at least one elongated recess may form a selected pattern. Such a pattern may be desirable for identifying a particular septum.

[0071] In other embodiment contemplated by the instant disclosure, a septum may include at least one protrusion and at least one recess configured for perception and identification of the septum. For example, FIGS. **27** and **28** show a perspective view and a schematic side cross-sectional view (taken through recess **150** and protrusion **130**), respectively, of a septum **118** including a recess **140** and a protrusion **130**. Recess **140** and protrusion **130** may be structured relative to one another for perception (e.g., visually or by palpation) and identification of the septum **118**. As mentioned above, a recess, a protrusion, or both (if present) may be tapered. As shown in FIGS. **27** and **28**, each of recess **140** and protrusion **130** taper generally with respect to an increasing distance from septum surface **121**. More particularly, as shown in FIG. **28**, recess **140** is defined by a tapered side surface **145** and a substantially planar surface **147**. As shown in FIG. **28**, tapered side surface **145** is frustoconical and increases in size with respect to an increase in distance from septum surface **121**. In addition, as shown in FIG. **28**, protrusion **130** is defined by a tapered side surface **135** and a substantially planar surface **137**. As shown in FIG. **28**, tapered sidewall **135** is frustoconical and decreases in size with respect to an increasing distance from septum surface **121**. Of course, either of recess **140** or protrusion **130** may increase in size with respect to an increasing distance from septum surface **121**, if desired. Furthermore, as mentioned above, a cross-sectional shape of either of recess **140** or protrusion **130** may be selected from any number of geometries as known in the art. Accordingly, a tapered side surface forming a tapered recess or protrusion may define a frustum exhibiting a selected geometry. In summary, the

combination of at least one recess and at least one protrusion may comprise at least one identifiable feature of a septum and may be beneficial for perception and identification of such a septum.

**[0072]** The instant disclosure contemplates various configurations of a septum including at least one protrusion and at least one recess. For example, FIGS. 29 and 30 show a perspective view and a schematic side cross-sectional view, respectively, of a septum 118 including a recess 150 and a protrusion 130. Further, as shown in FIGS. 29 and 30, protrusion 130 is positioned generally within recess 150. Also as shown in FIGS. 29 and 30, both recess 150 and protrusion 130 may be generally centered with respect to central access 111. Of course, in other embodiments, neither of recess 150 nor protrusion 130 may be centered with respect to central access 111. In addition, protrusion 130 may be positioned upon and may extend from any portion of substantially planar surface 157 or sidewall surface 155, without limitation.

**[0073]** Accordingly, the instant disclosure contemplates that at least one protrusion, protruding region, recess, recessed region, undulation, or adjacent features of different elevation may comprise a feature for identifying a septum of an access port. For example, in a further embodiment, a plurality of protrusions 80 may be spaced about a selected center or other point on a septum surface of a septum. FIG. 31 shows a perspective view of an exemplary embodiment of a septum 118 including protrusions 130 positioned substantially symmetrically about a center of revolution 115. Center of revolution 115, as shown in FIG. 31, is a point upon septum surface 121 with which axis 113 intersects. Axis 113 may be aligned with a central axis of septum 118, or may be otherwise positioned or oriented. Thus, protrusions 130 may be substantially equidistantly spaced from center of revolution 115 and may be substantially equally circumferentially spaced with respect to one another and about center of revolution 115. Similarly, a plurality of recesses 150 may be substantially symmetrically spaced about center of revolution 115. In another embodiment, one or more of protrusions 130, one or more recesses 150, or both may be positioned upon one or more selected closed plane figure (e.g., a circle, ellipse, rectangle, triangle, etc.) for identifying a septum.

**[0074]** Further, in another embodiment, a topography of a septum may comprise elongated protrusions and elongated recesses. FIG. 32 shows a perspective view of one embodiment of such a septum, including alternating, circumferentially extending, elongated protrusions 140 and circumferentially extending, elongated recesses 160. Optionally, the circumferentially extending, elongated protrusions 140 may be circumferentially substantially equal in size with respect to the circumferentially extending, elongated recesses 160. In another embodiment a septum may exhibit an upper topography comprising alternating, circumferentially extending, elongated protrusions and circumferentially extending, elongated recesses that are unequal in circumferential size. Optionally, it may be appreciated that, optionally, transition regions may extend circumferentially between circumferentially extending, elongated protrusions 140 and circumferentially extending, elongated recesses 160. Such transition regions may taper or generally smoothly transition between a circumferentially extending, elongated protrusion 140 (or any other protrusion or protruding region) and an adjacent circumferentially extending, elongated recess 160 (or any other recess or recessed region). Thus, such transition regions

may form an undulating topography that generally smoothly transitions between circumferentially adjacent protrusions and recessed regions.

**[0075]** It should also be understood that the instant disclosure contemplates access ports having a septum with an exposed surface defined, at least in part, by a periphery that is not circular in nature. Rather, the instant disclosure contemplates that an access port may have a periphery which is generally quadrilateral, generally rectangular, generally triangular, generally elliptical, generally oval, generally polygonal, or otherwise configured. It should also be understood from the discussion of the above-described various embodiments of a septum of an access port that variations, additions, combinations, or different features are encompassed by the instant disclosure. Thus, the instant disclosure is not limited to the above-described exemplary embodiments.

**[0076]** Generally, the instant disclosure contemplates that means for identifying a septum may be provided. In one embodiment, as described above, at least one topographical feature may comprise means for identifying a septum. In another embodiment, at least one visual feature may be perceived and used to identify a septum. For example, a color, a pattern, one or more letters, one or more numbers, symbols, any indicia, or combinations thereof, may be formed upon or as a portion of a septum. Such a configuration may allow for visual perception and identification of a septum. In addition, the instant disclosure also contemplates that at least one feature of an access port of the instant disclosure may not be observable visually or by palpation but, rather, may be otherwise observable. For example, means for identifying a septum may comprise at least one feature observable through interaction with an imaging technology such as x-ray or ultrasound. For instance, a metal feature (e.g., a plate or other metal geometry) may be included within a septum of an access port. As may be appreciated, such a metal feature may be represented on an x-ray generated by exposure of the access port to x-ray energy while simultaneously exposing x-ray sensitive film to x-ray energy passing through the access port. Further, the instant disclosure contemplates that a size, shape, or both size and shape of a metal feature of an access port may be configured for enhancing identification of an access port. For example, assuming that a metal feature comprises a metal plate, a size, shape, or both may be selectively tailored for identification of a septum. Similarly, a feature of an access port of the may be tailored for detection via ultrasound interaction. Such a feature may comprise an exterior topographical feature. In another embodiment, such a feature may comprise a composite structure including two or more materials that form an interface (i.e., an interior feature or surface) that may be identified by ultrasound imaging. In a further aspect of the instant disclosure, it is contemplated that a communicative technology may be utilized wherein information is encompassed by an access port of the instant disclosure. Generally, a communication device (e.g., a radio beacon, a light-emitting element, an ultrasound emitting transducer, etc.) may be imbedded or otherwise affixed to a septum of the instant disclosure. Such a communication device may be configured for transmitting information in response to a given impetus. More specifically, a septum may be exposed to a request signal (e.g., a sound, an impact or an acceleration, light, radio waves, etc.). Such a request signal may cause the communication device to transmit information therefrom via sound, light, radio waves, or as otherwise

known in the art. Such information may be employed for identifying an access port of the instant disclosure. Thus, a wide variety of means for identifying a septum may be employed for identifying a septum.

[0077] In one exemplary example, radio frequency identification technology may be employed for identification of a septum of an access port. Particularly, so-called active RFID tags are powered by an internal battery and are typically read/write devices. Currently, a suitable cell coupled to suitable low power circuitry can ensure functionality for as long as ten or more years, depending upon the operating temperatures and read/write cycles and usage. So-called passive RFID tags operate without a separate external power source and obtain operating power generated from the reader. Passive RFID tags are typically programmed with a unique set of data (usually 32 to 128 bits) that cannot be modified. Read-only tags may operate as an identifier comparable to barcodes, which may contain selected product-specific information. Thus, passive RFID tags may be much lighter than active RFID tags, less expensive, and may offer a substantially unlimited operational lifetime. In one embodiment, an RFID tag may be affixed to an exterior surface of a septum. In another embodiment, an RFID tag may be imbedded within a septum. One advantage of RFID approach is the noncontact, non-line-of-sight nature of the technology. RFID tags can be read through a variety of visually and environmentally challenging conditions, where other optically related technologies may be less effective.

[0078] As will be appreciated by those skilled in the art, any septum configured according to the above described aspects of the instant disclosure may be incorporated within a housing or body to form an access port. For example, FIG. 33 shows an exploded assembly view of one embodiment of an access port 50 including a septum 118 that comprises a plurality of protrusions 130. More particularly, septum 118 may be positioned between a cap 54 and base 56 (collectively forming a housing) to form an access port 50. As shown in FIG. 33, base 56 may include a raised retaining wall 79 forming a recess into which septum 118 may be positioned. Further, cap 54 may fit generally about the raised retaining wall 79 and may capture septum 118 between base 56 and septum 54 to form a cavity within the access port 50. Also, aperture 59 may be formed by cap 54 and may allow access to septum 118 when the septum 118 is captured between cap 54 and base 56. Further, as shown in FIG. 33, outlet stem 71 may include a stem base 73 that may be positioned within and sealed to an outlet recess 93 formed within base 56. Of course, the outlet stem 71 may be in fluid communication with a cavity formed within the access port 50. Optionally, suture plugs 89 may be positioned within suture cavities 91 formed in base 56. Suture plugs 89 may comprise a pliant material (e.g., silicone, rubber, etc.) that may provide some resilience between sutures coupling the access port (i.e., the base 56) to a patient.

[0079] In further detail, FIG. 34 shows a perspective view of an assembled access port 50. As shown in FIG. 34, a side periphery 95 (e.g., one or more side walls) of access port 50 may be generally triangular. Thus, cap 54 and base 56 may collectively form a generally triangular housing or body of access port 50. Also, the instant disclosure contemplates that side periphery 95 may taper or arcuately extend between upper surface 61 of cap 54 and lower surface 51 of base 56. As shown in FIG. 34, a transverse cross section (taken in a selected plane substantially parallel to lower surface 51, if

planar, of base 56) of access port 50 may be larger proximate to lower surface 51 of base 56 and may be relatively smaller proximate upper surface 61 of cap 54. FIG. 35 shows a top elevation view of the access port 50 shown in FIG. 35 and illustrates a generally triangular shape defined by side periphery 95. Additionally, FIG. 36 shows a simplified representation of a transverse cross section of access port 50. As shown in FIG. 36, side periphery 95 of access port 50 may define three side regions 103 that extend between associated vertex regions 101. In addition, in one embodiment and as shown in FIG. 36, side periphery 95 may define a substantially equilateral generally triangular shape. As may be appreciated, side regions 103 may arcuately extend between associated vertex regions 101; thus, side regions 103 may form “sides” of a generally triangular shape. Further, although vertex regions 101 are rounded, it may be appreciated that such vertex regions 101 form an intersection between adjacent side regions 103. Accordingly, it may be appreciated that the phrase “generally triangular,” as used herein, encompasses any generally three-sided geometry wherein adjacent sides intersect, without limitation. For example, “generally triangular” encompasses three sided polygons, circular triangles, equilateral triangles, etc., without limitation.

[0080] While certain representative embodiments and details have been shown for purposes of illustrating aspects of the instant disclosure, it will be apparent to those skilled in the art that various changes in the methods and apparatus disclosed herein may be made without departing from the scope of the instant disclosure, which is defined in the appended claims. For example, other access port sizes and shapes may be employed; and various other embodiments and structures may be employed for forming at least one identifiable feature of an access port of the instant disclosure.

What is claimed is:

1. A power-injectable access port, comprising:
  - a body capturing a septum that covers a cavity defined by the body; and
  - a pattern of protrusions extending from an outer surface of the septum away from the cavity, the pattern of protrusions detectable through palpation to identify the access port as a power-injectable access port.
2. A power-injectable access port according to claim 1, wherein the pattern of protrusions comprises three substantially identical protrusions.
3. A power-injectable access port according to claim 2, wherein the three substantially identical protrusions are positioned substantially equidistantly from a central axis of the septum in a triangular pattern.
4. A power-injectable access port according to claim 1, wherein the pattern of protrusions comprises protrusions that are elongated and extend linearly or arcuately.
5. A power-injectable access port according to claim 4, wherein the elongated protrusions form a plurality of substantially linear ridges.
6. A power-injectable access port according to claim 5, wherein the substantially linear ridges are parallel to each other.
7. A power-injectable access port according to claim 6, wherein the parallel substantially linear ridges are formed equidistant from a central axis.
8. A power-injectable access port according to claim 4, wherein the elongated protrusions intersect substantially near the center of the septum and extend at least partially toward a periphery thereof.

**9.** A power-injectable access port according to claim **8**, wherein the elongated protrusions extend to the periphery of the septum.

**10.** A power-injectable access port according to claim **4**, wherein the elongated protrusions form a pattern of intersecting lines.

**11.** A power-injectable access port according to claim **1**, wherein the protrusions comprise frustoconical circumferential sides and a flat top surface.

**12.** A power-injectable access port according to claim **1**, further comprising at least one recess extending into the outer surface of the septum.

**13.** A power-injectable access port according to claim **12**, further comprising three recesses extending into the outer surface of the septum positioned substantially equidistant from the central axis of the septum.

**14.** A power-injectable access port according to claim **1**, further comprising a plurality of recesses on the outer surface of the septum extending into the septum.

**15.** A power-injectable access port according to claim **14**, wherein the plurality of recesses and the pattern of projections are positioned equidistant from an axis of the access

port, such that an elongated recess is separated from an adjacent elongated recess by a projection.

**16.** A power-injectable access port according to claim **15**, wherein the recesses and the projections are curved to create a generally circular pattern.

**17.** A power-injectable access port according to claim **1**, wherein each of the protrusions includes a surface remote from the outer surface of the septum that is rounded.

**18.** A power-injectable access port according to claim **1**, wherein a side periphery of the access port is generally triangular.

**19.** A method of identifying a subcutaneously implanted power-injectable access port, comprising:

providing a power-injectable access port including a septum having a pattern of protrusions extending from an outer surface thereof, the pattern of protrusions detectable through palpation to identify the access port as a power-injectable port;

detecting the protrusions through palpation; and  
identifying the access port as a power-injectable port.

\* \* \* \* \*