



EUROPEAN PATENT SPECIFICATION

Date of publication of patent specification :
29.11.95 Bulletin 95/48

Int. Cl.⁶ : **H01J 29/82, H01J 9/18**

Application number : **91200884.4**

Date of filing : **15.04.91**

Cathode ray tube comprising an electron gun.

Priority : **20.04.90 NL 9000943**

Proprietor : **Philips Electronics N.V.**
Groenewoudseweg 1
NL-5621 BA Eindhoven (NL)

Date of publication of application :
23.10.91 Bulletin 91/43

Inventor : **Van Eck, Arnoldus Hubertus Maria**
c/o INT. OCTROOIBUREAU B.V.
Prof. Holstlaan 6
NL-5656 AA Eindhoven (NL)

Publication of the grant of the patent :
29.11.95 Bulletin 95/48

Designated Contracting States :
AT DE ES FR GB

Representative : **Koppen, Jan et al**
INTERNATIONAAL OCTROOIBUREAU B.V.,
Prof. Holstlaan 6
NL-5656 AA Eindhoven (NL)

References cited :
US-A- 4 096 408

EP 0 453 039 B1

Note : Within nine months from the publication of the mention of the grant of the European patent, any person may give notice to the European Patent Office of opposition to the European patent granted. Notice of opposition shall be filed in a written reasoned statement. It shall not be deemed to have been filed until the opposition fee has been paid (Art. 99(1) European patent convention).

Description

The invention relates to a cathode ray tube comprising an electron gun having at least one electrode and at least one support of a material which can be softened, the support and the electrode being inter-connected.

A cathode ray tube is known from United States Patent Specification US-A-4,096,408. In said specification, a description is given of a cathode ray tube comprising an electron gun having electrodes and supports. The supports and the electrodes are inter-connected.

Cathode ray tubes are used, inter alia, in display devices such as, for example, colour televisions, oscilloscopes, projection televisions and DGD (Data Graphic Display) apparatuses.

A factor which is important to the quality of an electron gun is the sensitivity to vibrations, the so-called microphonic behaviour. Vibrations can be caused by external influences, for example by sound vibrations which are transmitted to the electron gun or by conditions inside the electron gun, for example varying electric voltages between the electrodes. Vibrations disturb the mutual positioning of the electrodes, thus causing the position and intensity of the electron beam(s) generated by the electron gun to be subject to time-dependent variations. As a result thereof, images produced by the electron beam(s) on, for example, a display screen of the cathode ray tube are subject to time-dependent variations which adversely affect picture quality.

One of the objects of the invention is to provide a cathode ray tube of the type mentioned in the opening paragraph, which exhibits an improved microphonic behaviour.

For this purpose, the cathode ray tube according to the invention is characterized in that the electrode is provided with a serrated clamping member in which the support is held, the serrations in the clamping member clamping said support at the periphery of the support.

In the known cathode ray tubes, one or more projections are pressed into a support after which the projection(s), which has (have) expanded as a result of the heat, cool(s) down and become(s) clamped in the support.

The invention relates to changing the electrode such that during the pressing together of the support and the electrode, the support can be pressed into the serrated clamping member. Said clamping member encloses a large portion of the circumference of the support and the electrode is fixed at the periphery of the support by means of the serrations in the clamping member.

In this manner, an improved connection between the electrode and the support is obtained. By virtue of the larger clamping area, several clamping points

instead of one pair and a larger distance between said clamping points, the connection has a larger stability. Also the stability of the support is larger because the serrations do not penetrate the support as deeply as the known projections. By virtue hereof, a more stable construction and an improved microphonic behaviour of the electron gun is obtained.

The shape of the support preferably corresponds to that of the clamping member.

By virtue hereof, a further improved connection between the electrodes and the supports is obtained.

In an embodiment, the bottom of the clamping member is smaller or equally large as the front side of the clamping member and the serrations are provided between the bottom and the front side of said clamping member.

Preferably, a hillock is formed on the bottom of the clamping member, which causes the material of the support to be urged to serrations located close to the bottom of the clamping member during the pressing together of the electrode and the support. This results in an improved connection between the electrodes and the support.

Preferably, the serrations are formed such that the distance between the serrations, as a function of the distance to the bottom of the clamping member in a direction transverse to the bottom, exhibits local minima.

This results in an improved connection between the electrode and the support.

In an embodiment, the electron gun comprises more than one electrode and more than one support.

The invention also relates to a method of manufacturing a cathode ray tube, in which electrodes of an electron gun and supports of softenable material are interconnected in a manufacturing step by heating the supports to the softening temperature of the support material and pressing the supports and the electrodes against each other, such that the support is pressed into a serrated clamping member formed at the electrode, after which the assembly of electrodes and supports is left to cool.

In an embodiment of the method according to the invention, forces are exerted on the material of the support with a component transverse to the serrations, while the supports and the electrodes are being pressed together.

The invention will be explained in greater detail by means of several exemplary embodiments of the cathode ray tube according to the invention and with reference to the accompanying drawing, in which

Fig. 1 is a sectional view of a cathode ray tube comprising an electron gun;

Fig. 2 is a partly perspective elevational view of an electron gun suitable for use in a cathode ray tube;

Fig. 3 is a top view of an electrode suitable for use in a known cathode ray tube;

Fig. 4 is a top view of an electrode suitable for use in a cathode ray tube according to the invention; Figs. 5 and 6 are top views of further examples of suitable electrodes;

Fig. 7 is a sectional view of a support to which an electrode is attached;

Figs. 8a to 8c are sectional views of a support, in which Figures the parts which are heated to the softening temperature are indicated;

Fig. 9a is a top view of a part of an electrode;

Figs. 9b and 9c are graphic representations of the shape of the clamping member;

Figs. 10a and 10b are perspective and top views, respectively, of a box-shaped electrode.

All Figures are diagrammatic representations, corresponding parts generally bearing the same reference numerals.

Fig. 1 is a sectional view of a cathode ray tube comprising an electron gun. In the present example, a colour display tube of the "in-line" type is shown. An electron gun 5 is provided in the neck 4 of a glass evacuated envelope 1 which is composed of a display window 2, a cone 3 and a neck 4, said electron gun generating three electron beams 6, 7 and 8 whose axes are located in the plane of the drawing. The axis of the central electron beam 7 initially coincides with the tube axis 9. A large number of triads of phosphor elements 10 are provided on the inside of the display window 2. Said elements may consist of, for example, lines or dots. In the present example, the display window contains linear elements. Each triad contains a line consisting of a phosphor luminescing in green, a line consisting of a phosphor luminescing in blue and a line consisting of a phosphor luminescing in red. Said phosphor lines extend transversely to the plane of the drawing. In front of the display screen 2 there is provided a shadow mask 11 having a large number of apertures 12 for passing the electron beams 6, 7 and 8 which each impinge only on phosphor lines of one colour. The three coplanar electron beams are deflected by the deflection coil system 13.

Fig. 2 is a partly perspective elevational view of an electron gun 20. The electron gun comprises a common control electrode 21 in which three cathodes 22, 23 and 24 are secured. Said common control electrode 21 is secured to supports 26 by means of securing members 25. The electron gun 20 further comprises a common plate-shaped electrode 27 which is connected to the supports through parts 28. The three coplanar electron beams are focused by a common electrode 29, which is provided with securing members 30, and a common electrode 31 which is provided with securing members 32. The supports are connected to feed-through pins 35 by means of supporting brackets 33 having securing members 34. In the present example, the electron gun 20 comprises two supports. The construction shown shall not be interpreted limiting the scope of the invention. The

electron gun may comprise more than two supports.

Fig. 3 is a top view of an electrode suitable for use in a known cathode ray tube. Said electrode, in the present example a plate-shaped electrode 27, is provided with projections 28 having a dovetailed recess. Said projections are pressed into the supports 26. The electrode comprises apertures 36 for passing the electron beams.

Fig. 4 is a top view of an electrode 40 suitable for use in a cathode ray tube according to the invention. Electrode 40 comprises a clamping member 41 having serrations 42 between the bottom and the front at two facing sides of the clamping member. The support 26 is clamped by said serrations.

By virtue hereof, an improved connection between the electrodes and the supports is obtained. As a result of the larger clamping area, several clamping points instead of one pair and a larger distance between said clamping points, the stability of the connection has increased. Also the stability of the support has increased because the serrations do not penetrate the support as far as the projections. This results in a more stable construction and, hence, an improved microphonic behaviour of the electron gun. In addition, the electrode 40 is more rigid than the electrode 27 as a result of the shape of the clamping member, which brings about an improved microphonic behaviour.

The bottom of the clamping member has a length D_1 , the front side of the clamping member has a length D_2 . In this example, the bottom of the clamping member is smaller than the front side and the serrations are located between the bottom and the front side of the clamping member.

In the present example, a hillock 43 is formed on the bottom of the clamping member. This is a means of exerting forces on the support which urge the material of the support to the serrations, while the support and the electrode are being pressed together. By virtue hereof, the effectiveness of the serrations close to the bottom are improved.

Figs. 5 and 6 are top views of further examples of clamping members 41 of electrodes suitable for use in a cathode ray tube according to the invention. In Fig. 5, clamping member 41 forms an at least substantially U-shaped recess. In Fig. 6, clamping member 41 forms a recess in the form of a half arc. Figs. 5 and 6 are also sectional views of supports 26 and 61. The shapes of said supports are adapted to the shape of the clamping member.

Fig. 7 is a sectional view of a support 26. In said support 26 there are secured two electrodes, electrode 27 as shown in Fig. 3 having projection 28, and electrode 40 as shown in Fig. 4 having clamping member 41. It has been found that during interconnecting the electrodes and the support, said support exhibits less deformation next to electrode 40 than next to electrode 27. Fig. 7 shows how the use of the

known electrode causes the support to bulge in the immediate vicinity of the electrode 27, which does not happen, or to a much lesser extent, in the direct vicinity of the electrode 40. As a result thereof, fewer stresses occur in the carrier. The risk of fracture is reduced and the accuracy with which the electrode is positioned is improved. In addition, the charging of the support is reduced.

Figs. 8a, 8b and 8c illustrate a further advantage of the invention. Supports 26 and 81 are shown in section. The hatching in Fig. 8a indicates the portion 81 which has to be heated to at least the softening temperature when the support and the electrode 27 are interconnected. Fig. 8b shows the portion 81 which has to be heated to the softening temperature when an electrode 40 having a clamping member 41, as shown in Fig. 4, is used. This is a smaller portion than portion 81 in figure 8a. By virtue hereof, a saving of time can be attained and the electrode can be more accurately positioned relative to the support. Fig. 8c shows a support whose shape is adapted to that of the clamping member shown in Fig. 6. In this case, the portion 83 to be heated to the softening temperature is even smaller than in Fig. 8b.

Fig. 9a is a top view of a clamping member 41 having serrations 42. The distance D between the serrations 42 varies as a function of x, in such a manner that for the points 44 the distance D exhibits a local minimum. This is graphically shown in Figs. 9b and 9c. After cooling, the clamping member clamps the support through the points 44 (Fig. 9b) or 44' (Fig. 9c).

In an embodiment, the clamping member may be formed by two plate-shaped elements which are serrated on the inside as shown in Figs. 10a and 10b. By virtue hereof, the connection can be further improved.

Figs. 10a and 10b are perspective and top views, respectively, of a box-shaped electrode 100. In the top surface 101 there are provided apertures 102, 103 and 104. A bracket 105 is provided at a side wall. Said bracket 105 contains two plate-shaped elements 106 and 107, the facing sides of which are provided with serrations 108.

It will be obvious that many variations are possible within the scope of the invention. In the present example, an "in-line" colour display tube is shown. This is not to be interpreted in a limiting sense. The cathode ray tube may be a monochrome display tube, for example a projection cathode ray tube. The cathode ray tube may be an oscilloscope cathode ray tube or any other type of cathode ray tube. Within the scope of the invention, "clamping member" is to be understood to mean, inter alia, a straight or conical embracing member such as, for example, a recess as shown in Figs. 4, 5, 6 and 9a or, for example, a duct as shown in Figs. 10a and 10b. "Serrations" are to be understood to include also ridges and barbs. A "serrated clamping member" is to be understood to mean

herein an embracing element having two facing sides which are provided with serrations. The support is clamped in the clamping member by means of said serrations.

Claims

1. A cathode ray tube comprising an electron gun (5, 20) having at least one electrode (21, 27, 29, 31, 40) and at least one support (26) of a material which can be softened, the support and the electrode being interconnected, characterized in that the electrode is provided with a serrated clamping member (41) in which the support is held, the serrations (42) in the clamping member clamping said support at the periphery of the support.
2. A cathode ray tube as claimed in Claim 1, characterized in that the shape of the support corresponds to the shape of the clamping member.
3. A cathode ray tube as claimed in Claim 1 or 2, characterized in that the bottom of the clamping member is smaller or equally large as the front side of the clamping member and the serrations are located between the bottom and the front side of the clamping member.
4. A cathode ray tube as claimed in Claim 1, 2 or 3, characterized in that a hillock (43) is formed on the bottom of the clamping member.
5. A cathode ray tube as claimed in Claim 1, 2, 3 or 4, characterized in that the serrations are formed such that the distance between the serrations, as a function of the distance to the bottom of the clamping member in a direction transverse to the bottom, exhibits local minima (44, 44').
6. A cathode ray tube as claimed in Claim 1, 2, 3, 4 or 5, characterized in that the clamping member is formed by two plate-shaped elements (106, 107) the facing sides of which are provided with serrations (108).
7. A cathode ray tube as claimed in Claim 1, 2, 3, 4, 5, 6 or 7, characterized in that the electron gun comprises more than one electrode and more than one support.
8. A method of manufacturing a cathode ray tube, in which electrodes (40) of an electron gun (5, 20) and supports (26) of softenable material are interconnected in a manufacturing step by heating the supports to the softening temperature of the support material and pressing the supports and the electrodes against each other, such that the

support is pressed at its periphery into a serrated clamping member (41) formed at the electrode, after which the assembly of electrodes and supports is left to cool.

9. A method as claimed in Claim 8, characterized in that forces are exerted on the material of the support with a component transverse to the serrations, while the supports and the electrodes are being pressed together.

Patentansprüche

1. Elektronenstrahlröhre mit einem Elektronenstrahlerzeugungssystem (5, 20) mit wenigstens einer Elektrode (21, 27, 29, 31, 40) und wenigstens einem Träger (26) aus einem erweichbaren Material, wobei der Träger und die Elektrode miteinander verbunden sind, dadurch gekennzeichnet, daß die Elektrode mit einem gezahnten Klemmelement (41) versehen ist, in dem der Träger festgehalten wird, wobei die Zähne (42) im Klemmelement den Träger am Umfang des Trägers einklemmen.
2. Elektronenstrahlröhre nach Anspruch 1, dadurch gekennzeichnet, daß die Form des Trägers der Form des Klemmelements entspricht.
3. Elektronenstrahlröhre nach Anspruch 1 oder 2, dadurch gekennzeichnet, daß der Boden des Klemmelements kleiner oder gleich groß wie die Vorderseite des Klemmelements ist, und daß die Zähne sich zwischen dem Boden und der Vorderseite des Klemmelements befinden.
4. Elektronenstrahlröhre nach Anspruch 1, 2 oder 3, dadurch gekennzeichnet, daß eine Oberflächenunebenheit (43) am Boden des Klemmelements gebildet wird.
5. Elektronenstrahlröhre nach Anspruch 1, 2, 3 oder 4, dadurch gekennzeichnet, daß die Zähne derart gebildet sind, daß der Abstand zwischen den Zähnen abhängig vom Abstand zum Boden des Klemmelements in einer Richtung quer zum Boden örtliche Mindestwerte (44, 44') aufweisen.
6. Elektronenstrahlröhre nach Anspruch 1, 2, 3, 4 oder 5, dadurch gekennzeichnet, daß das Klemmelement aus zwei plattenförmigen Elementen (106, 107) besteht, deren einander zugewandte Seiten mit Zähnen (108) versehen sind.
7. Elektronenstrahlröhre nach Anspruch 1, 2, 3, 4, 5, 6 oder 7, dadurch gekennzeichnet, daß das Elektronenstrahlerzeugungssystem mehr als ei-

ne Elektrode und mehr als einen Träger enthält.

8. Verfahren zum Herstellen einer Elektronenstrahlröhre, in dem Elektroden (40) eines Strahlerzeugungssystems (5, 20) und Träger (26) aus erweichbarem Material in einem Herstellungsschritt durch Erwärmen der Träger auf die Erweichungstemperatur des Trägermaterials und durch Andrücken der Träger und der Elektroden nacheinander hin miteinander derart verbunden werden, daß der Träger an seinem Umfang in ein gezahntes an der Elektrode gebildetes Klemmelement angedrückt wird, wonach die Gruppe von Elektroden und Trägern zum Abkühlen belassen wird.
9. Verfahren nach Anspruch 8, dadurch gekennzeichnet, daß auf das Material des Trägers mit einer Komponente quer zu den Zähnen Kräfte ausgeübt werden, während die Träger und die Elektroden aneinander gedrückt werden.

Revendications

1. Tube à rayons cathodiques comprenant un canon électronique (5, 20) ayant au moins une électrode (21, 27, 29, 31, 40) et au moins un support (26) en une matière qui peut être ramollie, le support et l'électrode étant interconnectés, caractérisé en ce que l'électrode est pourvue d'un élément de blocage dentelé (41) dans lequel le support est maintenu, les dentelures (42) de l'élément de blocage bloquant ledit support sur la périphérie du support.
2. Tube à rayons cathodiques selon la revendication 1, caractérisé en ce que la forme du support correspond à celle de l'élément de blocage.
3. Tube à rayons cathodiques selon la revendication 1 ou 2, caractérisé en ce que le fond de l'élément de blocage est plus petit ou aussi grand que le côté frontal de l'élément de blocage et les dentelures sont prévues entre le fond et le côté frontal dudit élément de blocage.
4. Tube à rayons cathodiques selon la revendication 1, 2 ou 3, caractérisé en ce qu'un bombage (43) est formé sur le fond de l'élément de blocage.
5. Tube à rayons cathodiques selon la revendication 1, 2, 3 ou 4, caractérisé en ce que les dentelures sont formées, de telle sorte que leur distance mutuelle présente des minima locaux (44, 44') en fonction de la distance jusqu'au fond de l'élément de blocage dans une direction transversale au fond.

6. Tube à rayons cathodiques selon la revendication 1, 2, 3, 4 ou 5, caractérisé en ce que l'élément de blocage est formé par deux éléments en forme de plaque (106, 107) dont les côtés qui se font face sont pourvus de dentelures (108). 5
7. Tube à rayons cathodiques selon la revendication 1, 2, 3, 4, 5, 6 ou 7, caractérisé en ce que le canon électronique comprend plus d'une électrode et plus d'un support. 10
8. Procédé de fabrication d'un tube à rayons cathodiques, dans lequel des électrodes (40) d'un canon électronique (5, 20) et des supports (26) en une matière ramollissable sont interconnectés au cours d'une étape de fabrication en chauffant les supports à la température de ramollissement de leur matière et en pressant les supports et les électrodes les uns contre les autres, de telle sorte que le support soit pressé, à sa périphérie, dans un élément de blocage dentelé (41) formé sur l'électrode, après quoi l'assemblage des électrodes et des supports est laissé à refroidir. 15
20
9. Procédé selon la revendication 8, caractérisé en ce que des forces sont exercées sur la matière du support avec une composante transversale aux dentelures, tandis que les supports et les électrodes sont pressés les uns contre les autres. 25
30

35

40

45

50

55

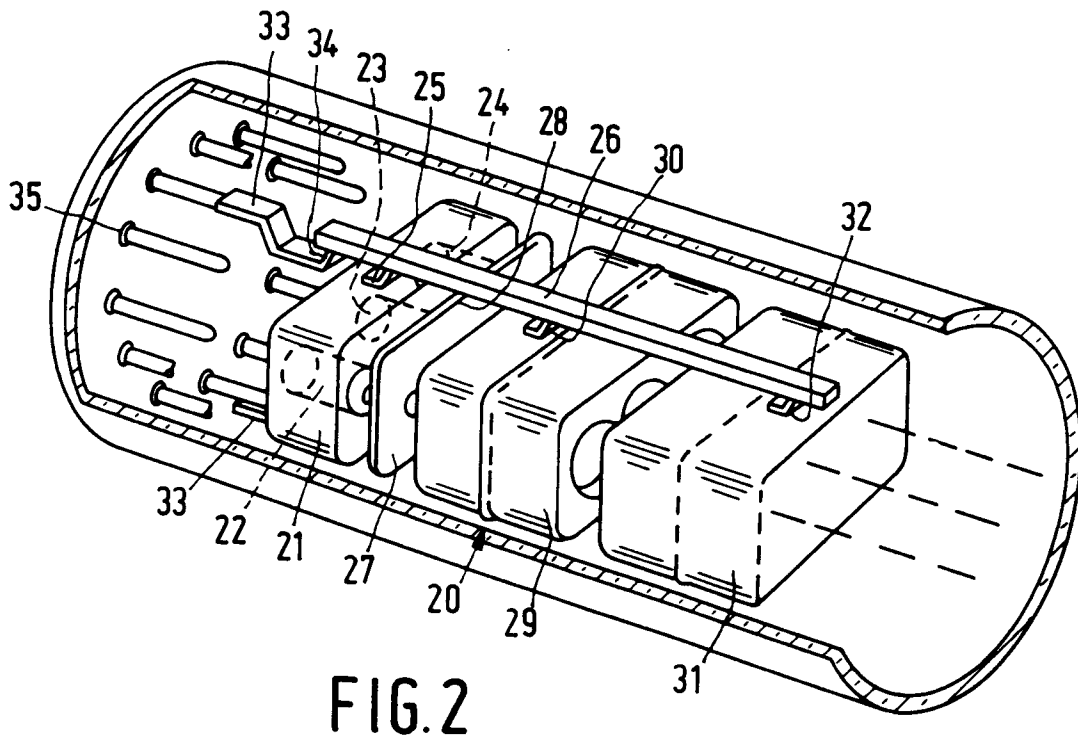
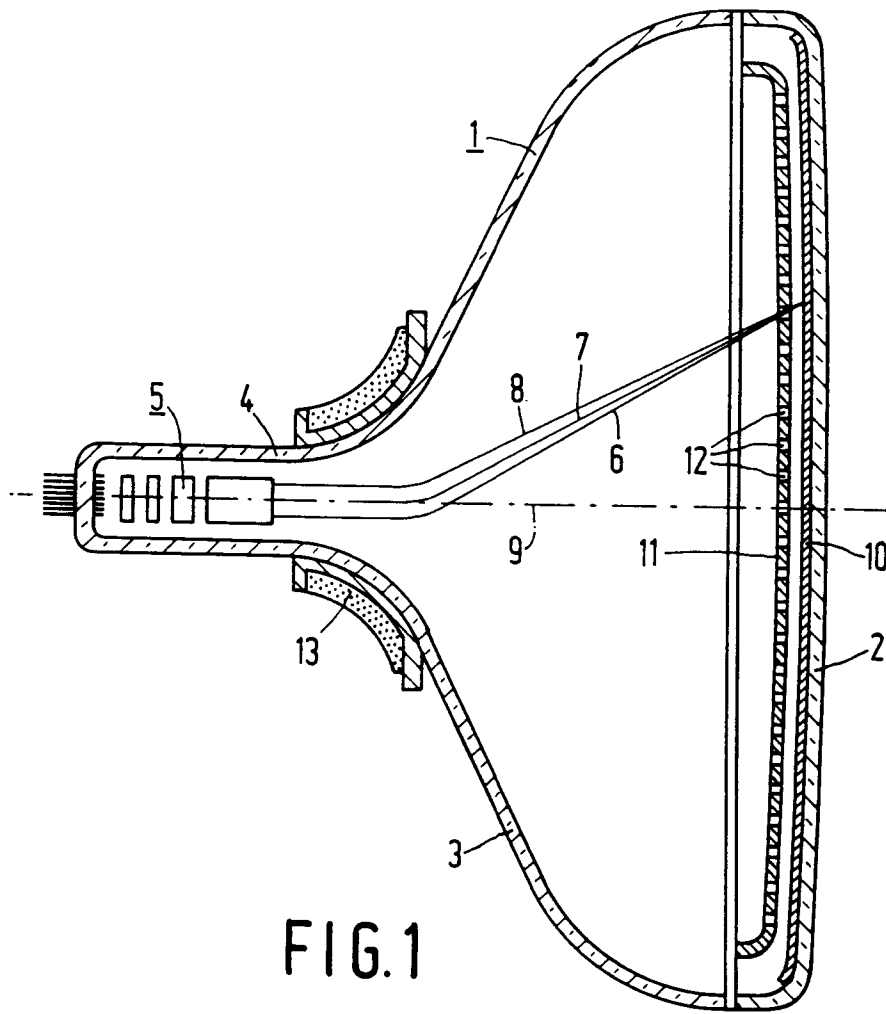

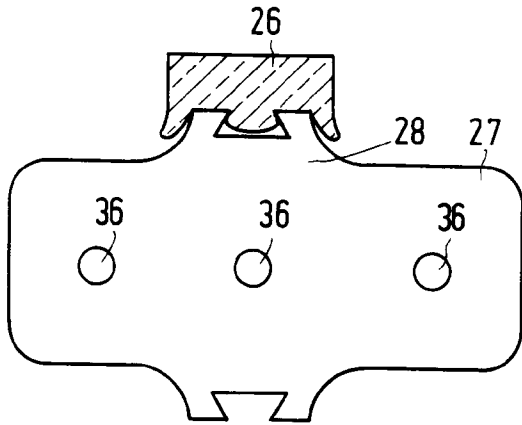

FIG. 3

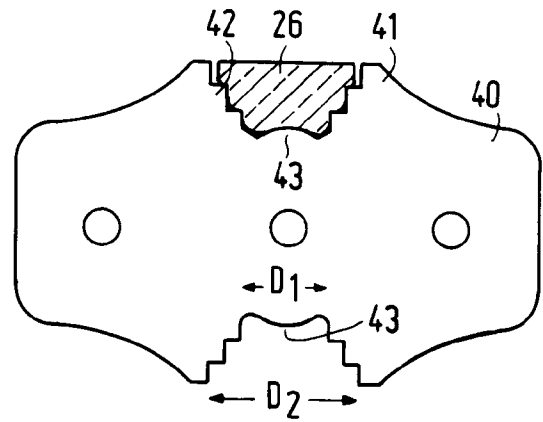

FIG. 4

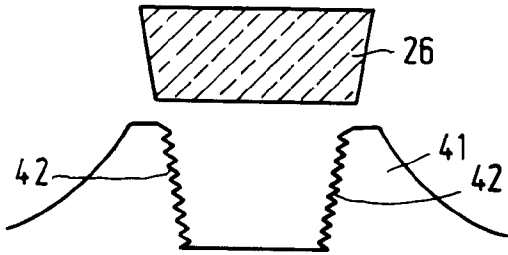

FIG. 5

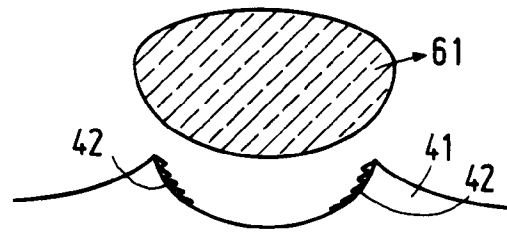

FIG. 6

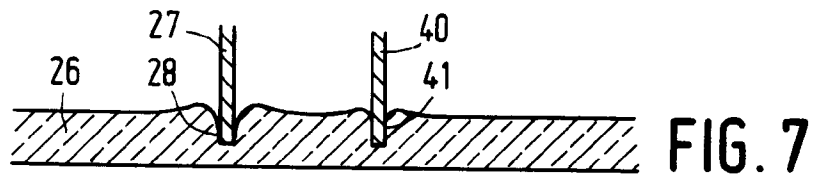

FIG. 7

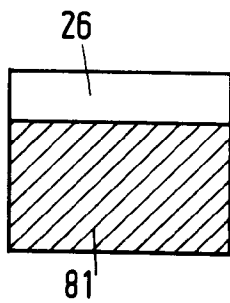

FIG. 8a

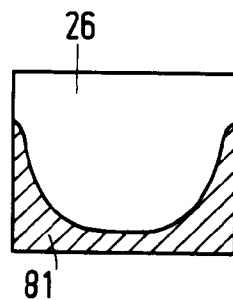

FIG. 8b

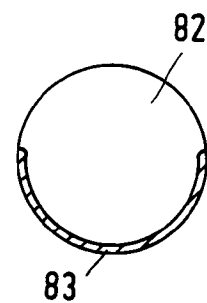

FIG. 8c

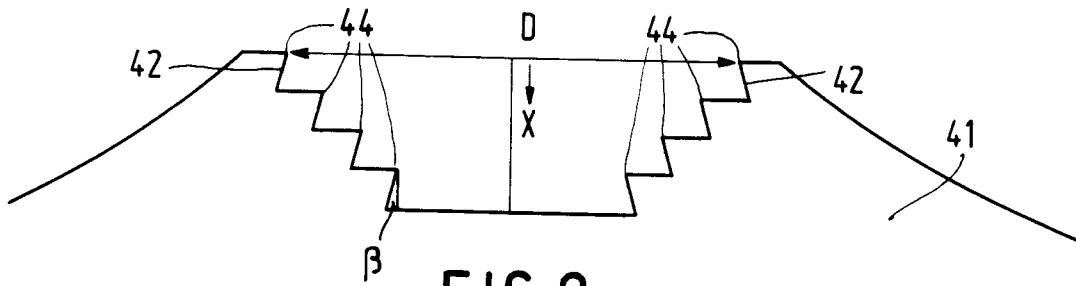

FIG. 9a

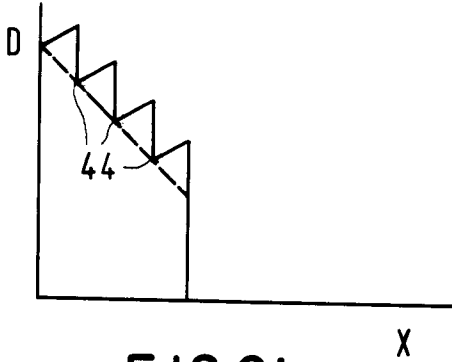

FIG. 9b

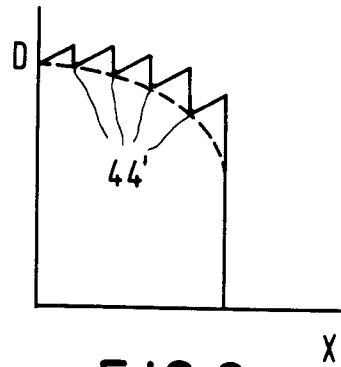

FIG. 9c

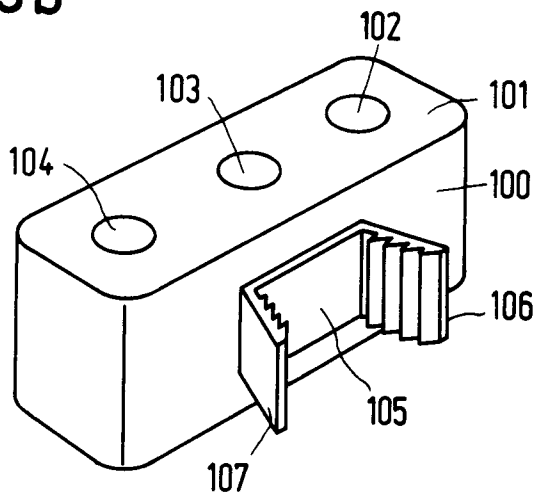

FIG. 10a

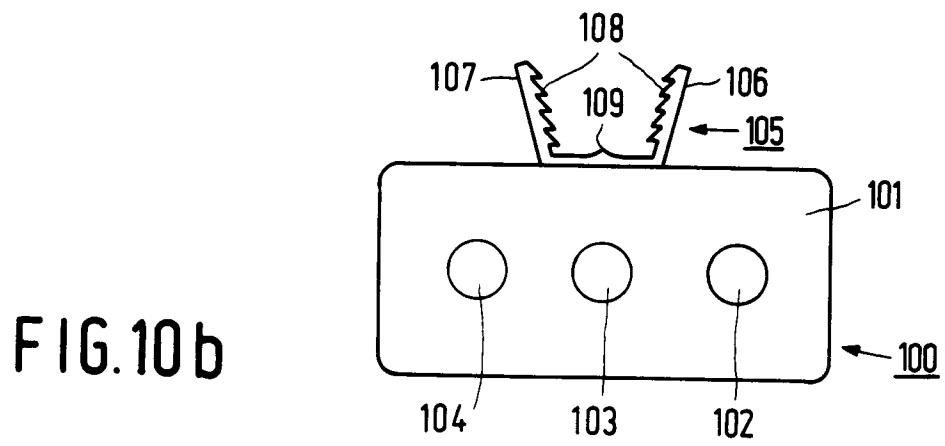

FIG. 10b