

A. MORAND.

Improvement in Brick-Machines.

No. 131,021.

Patented Sep. 3, 1872.

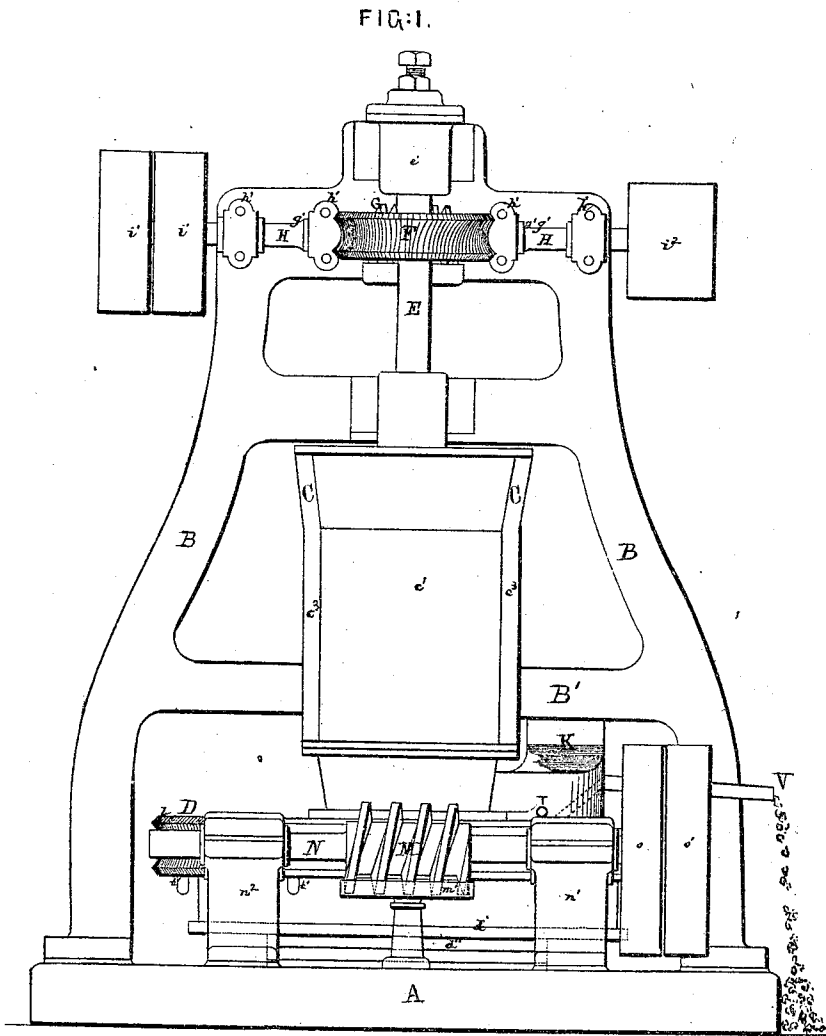

WITNESSES

R. H. Young
J. C. Burr

Augustus Morand
Inventor

By *David A. Burr*
att'y.

A. MORAND.

Improvement in Brick-Machines.

No. 131,021.

Patented Sep. 3, 1872.

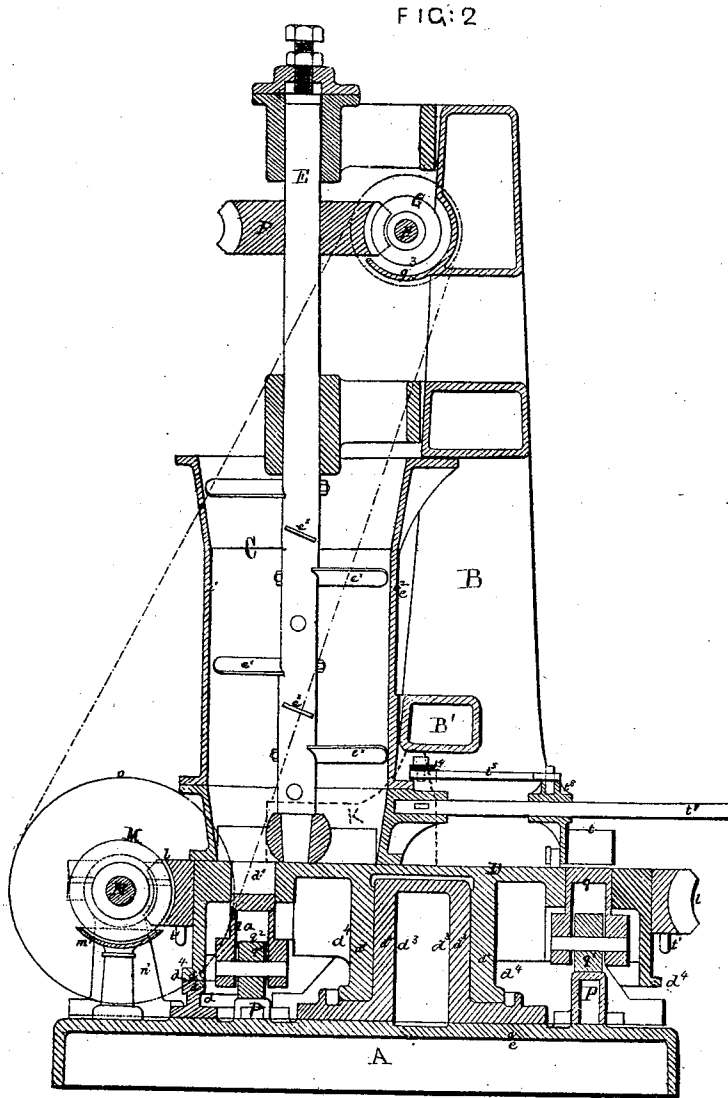

WITNESSES

H. H. Young
J. H. Blum

Augustus Morand
Inventor
By David A. Burr atty.

A. MORAND.

Improvement in Brick-Machines.

No. 131,021.

Patented Sep. 3, 1872.

FIG. 3

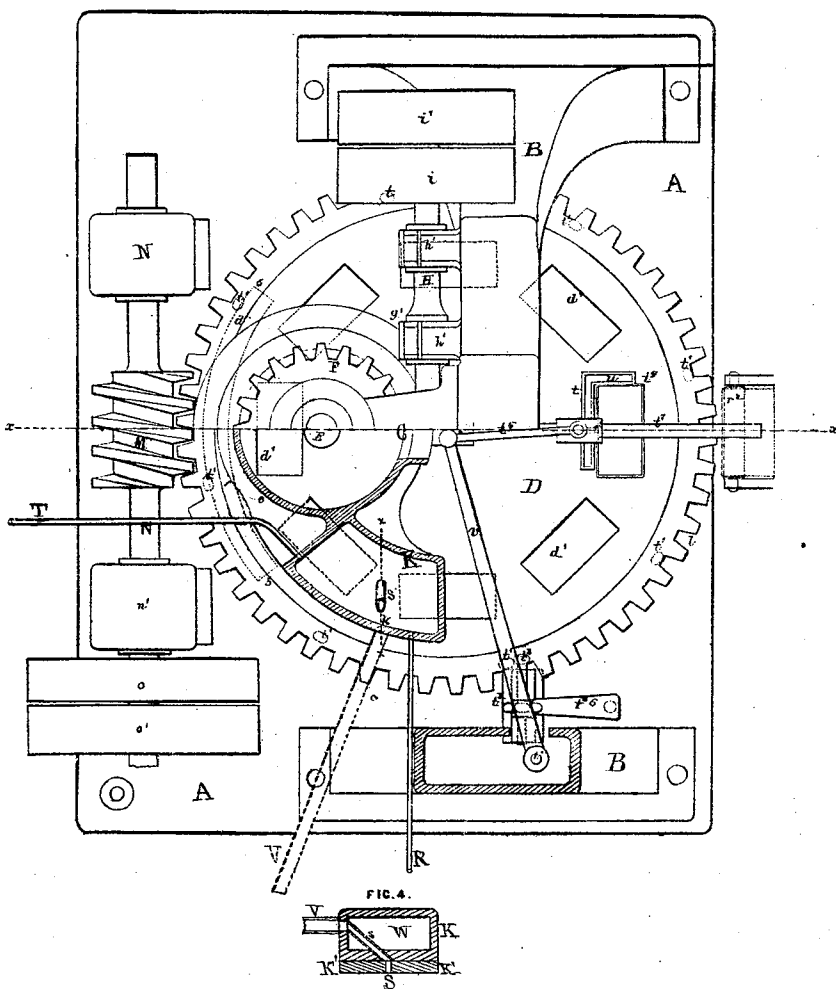

WITNESSES

F. H. Young
J. H. Burr

Augustus Morand

Inventor

By David A. Burr

Atty:

UNITED STATES PATENT OFFICE.

AUGUSTUS MORAND, OF BROOKLYN, NEW YORK.

IMPROVEMENT IN BRICK-MACHINES.

Specification forming part of Letters Patent No. 131,021, dated September 3, 1872.

SPECIFICATION.

I, AUGUSTUS MORAND, of Brooklyn, in the county of Kings and State of New York, have invented Improvements in Brick-Machines, of which the following is a specification:

My invention relates to that class of machines having a horizontally-rotating mold-wheel or table, combined with a vertical pug-mill placed over said table, and more especially to the improved machine for which I obtained Letters Patent of the United States numbered 116,341, and dated June 27, 1871. Said invention consists in forming a small aperture in the pressure-plate (or the thrust-block above) at such distance from its edges as that the central portion of the brick shall pass under said aperture just at the time it receives its most severe pressure; the object of this part of my invention being to provide a central escape for the surplus clay which otherwise would force itself out between the pressure-plate or thrust-block and the table, leaving the edges of the brick more or less ragged and rough, and clogging and impeding the movement of the machine.

In the accompanying drawing, Figure 1 is a back elevation of my improved brick-machine; Fig. 2, a central vertical section thereof in line *xx* of Fig. 1; Fig. 3, a plan view of the machine, partly in horizontal section; Fig. 4, a vertical section in line *xx* of Fig. 3, illustrating the construction and arrangement of the steam-chamber over the pressure-plate and of the waste-aperture therein.

A is the base-plate; B, the upright frame or standard; C, the pug-mill; and D, the mold-wheel or table of my improved brick-machine, constructed substantially as described in the Letters Patent granted to me June 27, 1871. E is the pug-mill shaft, and F a worm-wheel thereon. G is a worm or screw secured upon a horizontal driving-shaft, H, and geared in connection with the worm-wheel F. M is a worm or screw formed or secured upon a lower horizontal shaft, N, and geared into a series of teeth formed to engage the same on the periphery of the table D. K is the thrust-block, secured in the pug-mill at its lower edge, and so formed as to extend forward therefrom far enough and high enough at its front end, as shown in Fig. 1, and in dotted lines, Fig. 2, to abut under and bear against the cross-beam B' of the frame B. K' is a pressure-plate, of steel

or other hard metal, formed or secured upon the under side of the block K to form a face therefor, and which rests upon the revolving table D so as to cover the molds therein successively as they pass from under the pug-mill. *d' d'*, Figs. 2 and 3, are molds formed in the table D; and *q q*, Fig. 2, are pistons or followers working up closely and accurately into said molds, and provided with friction-rollers *q'* on their lower ends to work upon and against a circular incline-plate or cam-way below. P, Fig. 2, is the circular cam-plate or incline-way of the machine, secured horizontally upon the bed-plate A beneath the table D, and formed, first, with an upward incline immediately under the thrust-block K, so that the followers *q q*, in passing over it during the revolution of the table, will be partially forced up into their molds so soon as said molds pass from the pug-mill out under the pressure-plate of the thrust-block for the purpose of compressing the bricks formed therein; secondly, with a horizontal plane succeeding the first incline, so that the pressure shall cease so soon as the front edge of the mold has reached the outer edge of the pressure-block; thirdly, with a second upward incline to cause the followers to rise in the molds after the molds have passed out entirely clear of the pressure-plate, and thus to lift the bricks entirely out of the molds; and, finally, with a downward incline on the opposite side of the circle, to allow the followers to fall preparatory to a refilling of the molds. W is a hollow chamber formed in the thrust-block K, as illustrated in Figs. 3 and 4. R is a steam-pipe from the exhaust of the engine by which the machine is driven, and through it the exhaust-steam from the engine is carried into the chamber W. T is a discharge-pipe for the escape of the steam and condensed water from said chamber M. The pipe R may be connected with a furnace or with other suitable apparatus for supplying the chamber with heat, instead of using the exhaust from the engine for the purpose as described. By thus admitting steam or hot air into the thrust-block its pressure-plate K' is kept heated so that the clay in the molds will not adhere thereto, and thus the friction of the machine is very materially diminished. S is a small orifice or aperture formed in the pressure-plate K' at such a point as that the central portion of the brick shall pass un-

der it while undergoing pressure between the cam-actuated followers q below and the pressure-plate K' above. Over this orifice S , and within the thrust-block K , I place a tube, s , so inclined as to extend to the upper outer edge of the thrust-block and there open into a discharge-pipe, T ; or it may be extended up vertically through the thrust-block to open outwardly upon its upper surface. By means of this orifice S an outlet is supplied for any excess of clay in the mold at the moment of compression, and this excess, instead of being forced out at the edges of the mold between the table and the pressure-plate, clogging and impeding the operations of the machine and impairing the perfection of the edges of the

bricks, is, by this means, taken from the center of the brick so far as may be required, leaving the bricks perfectly true and smooth, and relieving the machine from undue strain.

I claim as my invention—

An orifice, S , formed in the pressure-plate K' , covering and closing the molds in the horizontal mold-table D of my improved brick-machine, and combined with a suitable discharge, tube, channel, or aperture, substantially as and for the purpose herein set forth.

AUGS. MORAND.

Witnesses:

MATTHIAS BANTEE,
JAS. F. CURTIS.