

(19) World Intellectual Property Organization
International Bureau



(43) International Publication Date
13 September 2001 (13.09.2001)

PCT

(10) International Publication Number
WO 01/66044 A2

- (51) International Patent Classification⁷: **A61F 2/28**
- (21) International Application Number: PCT/US01/06043
- (22) International Filing Date: 26 February 2001 (26.02.2001)
- (25) Filing Language: English
- (26) Publication Language: English
- (30) Priority Data:
09/517,981 3 March 2000 (03.03.2000) US
- (71) Applicant: **SMITH & NEPHEW, INC.** [US/US]; 1450 Brooks Road, Memphis, TN 38116 (US).
- (72) Inventors: **BEARCROFT, Julie**; 5676 Elmore Road, Bartlett, TN 38134 (US). **COOPER, Michael, B.**; 5665 Dunwoody Avenue, Memphis, TN 38120 (US). **KAISER, William, B.**; 603 South Rembert, Memphis, TN 38104 (US). **KINNANE, Keith, M.**; 3372 Oak Road, Bartlett, TN 38135 (US). **SCHRYVER, Jeff**; 9382 Riveredge Drive, Cordova, TN 38108 (US).
- (74) Agents: **PETROW, Joel** et al.; Smith & Nephew, Inc., 1450 Brooks Road, Memphis, TN 38116 (US).
- (81) Designated States (*national*): AE, AG, AL, AM, AT, AU, AZ, BA, BB, BG, BR, BY, BZ, CA, CH, CN, CR, CU, CZ, DE, DK, DM, DZ, EE, ES, FI, GB, GD, GE, GH, GM, HR, HU, ID, IL, IN, IS, JP, KE, KG, KP, KR, KZ, LC, LK, LR, LS, LT, LU, LV, MA, MD, MG, MK, MN, MW, MX, MZ, NO, NZ, PL, PT, RO, RU, SD, SE, SG, SI, SK, SL, TJ, TM, TR, TT, TZ, UA, UG, UZ, VN, YU, ZA, ZW.
- (84) Designated States (*regional*): ARIPO patent (GH, GM, KE, LS, MW, MZ, SD, SL, SZ, TZ, UG, ZW), Eurasian patent (AM, AZ, BY, KG, KZ, MD, RU, TJ, TM), European patent (AT, BE, CH, CY, DE, DK, ES, FI, FR, GB, GR, IE, IT, LU, MC, NL, PT, SE, TR), OAPI patent (BF, BJ, CF, CG, CI, CM, GA, GN, GW, ML, MR, NE, SN, TD, TG).
- Published:**
— without international search report and to be republished upon receipt of that report
- For two-letter codes and other abbreviations, refer to the "Guidance Notes on Codes and Abbreviations" appearing at the beginning of each regular issue of the PCT Gazette.*



WO 01/66044 A2

(54) Title: SHAPED PARTICLE AND COMPOSITION FOR BONE DEFICIENCY AND METHOD OF MAKING THE PARTICLE

(57) Abstract: A shaped particle for use in an array of interlocking particles to repair, replace, improve or augment a bone deficiency is provided. The particle in a preferred embodiment has six extremities, and the interstitial spaces between the extremities of one particle accept the extremities of an adjacent particle in an array. The particle is suspended in a material which facilitates application of the particle to bone, and the material may contain biological factors which augment bone growth or prevent infection. Furthermore, a method of making a shaped particle by producing a hardened calcium sulfate material is provided.

SHAPED PARTICLE AND COMPOSITION FOR BONE DEFICIENCY AND METHOD OF MAKING THE PARTICLE

The present invention generally relates to a shaped particle as a
5 bone graft substitute and the use of such a substitute to repair, replace,
augment or improve a bone deficiency. The invention also relates to a
composition having such a particle in a suspension material to enhance
the utility of the particle as a bone graft substitute. Furthermore, a method
of making an improved hardened calcium sulfate material for a shaped
10 particle is provided.

Bone graft is used to fill spaces in bone tissue that are the result of
trauma, disease degeneration or other loss of tissue. Clinicians perform
bone graft procedures for a variety of reasons, often to fill a bone void
15 created by a loss of bone or compaction of cancellous bone. In many
instances the clinician also must rely on the bone graft material to provide
some mechanical support, as in the case of subchondral bone
replacement or compaction grafting around total joint replacement devices.
In these instances, clinicians pack the material into the defect to create a
20 stable platform to support the surrounding tissue and hardware.

There are several options available to the orthopaedic clinician for
bone graft material. Most commonly, the source of the graft material is
either the patient (autograft) or a donor (allograft). In autograft and, to a
25 lesser extent, in allograft there are biological factors such as proteins or
cells that are present that can assist in the fracture healing process.
Xenografts and bone graft substitutes are other options.

Autograft is taken from the patient's own body and is the most
30 commonly used graft material. The graft, which can come in the form of
chips or blocks, is harvested from an ectopic bone site within the body,
such as the iliac crest, and used in the deficient site. Autograft has the
potential draw back of increased pain and morbidity associated with a

second surgical procedure, in addition to having a limited supply of the bone.

5 Allograft is another form of graft which comes from human bone tissue donated to tissue banks, such as from a cadaver. Allograft is available in a number of forms: granules or chips, blocks or struts, and processed forms such as gels or putties. In addition to having a limited supply, a serious drawback of allograft is the risk of disease transmission.

10 Xenografts are one such choice which come from non-human bone-tissue donors and are often processed and mixed with other components such as hydroxyapatite or other calcium salts. Again, xenografts are not favored for human use because of concerns over disease transmission and immunogenicity.

15 Given the disadvantages associated with autograft and allograft, many have focused efforts on developing new synthetic bone substitute materials that can fill the existing need.

20 Bone graft substitutes are materials other than human or non-human bone tissue. The advantages of a synthetically derived substitute material over human derived bone graft and naturally derived substitutes are: 1) more control over product consistency; 2) less risk for infection and disease; 3) no morbidity or pain caused by harvesting of the patient's own
25 bone for graft; and 4) availability of the substitute in many different volumes (that is, it is not limited by harvest site of the patient).

The biological and physical demands placed on a bone graft material vary in response to the treatment indication. For instance, clinicians prefer
30 different physical forms of the materials (granules, blocks, dense, porous, putty/paste, cement) depending on the difficulty filling a bone void sufficiently with graft. Craniomaxillofacial defects typically pose relatively

low loadbearing requirements on the graft material. The size of the defect may influence whether a conductive graft is sufficient or if an inductive graft is required. In some instances, a graft's ability to withstand high load and maintain structural support over a long period of time (such as in the case of compaction grafting around a revision joint prosthesis) is more important than the graft's ability to accelerate bone healing or bridge a gap (such as in the case of grafting to achieve spine fusion). For this reason, it is important to have more adaptable materials for bone graft over products currently available in the art, which fall short of easily conforming to a multitude of applications. Use of such a product would have the inherent advantage of being less costly and more efficient for personnel in orthopedics.

Two properties associated with currently available synthetic granules have inherent disadvantages. First, it is difficult to get the granules from the package into the defect. The granules are generally small, less than 10mm in any one dimension, and difficult to grasp individually. The granules have no means to form an aggregate, so clinicians cannot handle them in unison. Secondly, if the granules spill into an open surgical wound, the granules stick to soft tissue, which makes it difficult to clear them from the wound. Clinicians fear that if left in the wound, the granules can cause further complications such as migration into the articulating surfaces, potentially causing further damage.

Synthetic bone graft granules are commonly supplied in a simple glass vial, and very little has been done to improve the handling characteristics or ease the surgical procedure. There are a few exceptions. Although a syringe-like device is available on the market to assist in delivery of granules to the graft site, this does not address the issue of preferential sticking of the granules to soft tissue in the wound. Alternatively, demineralizing allograft products are commercially available which come premixed in a gel or putty for improved handling.

Other bone graft substitutes are known in the art. US Patent No. 5,676,700 is directed to interlocking structural elements for augmentation or replacement of bone in which at least four posts of the element project from a hub such that no more than two of the directions of any of the posts lie in a common plane. The elements have posts with oval cross-sections and in a preferred embodiment have an angle of 109.47 degrees between each post.

10 US Patent No. 5,178,201 is directed to an implant method, as opposed to a graft method, in which particles with from four to eight pins which extend radially from a center have at least three pins which adhere to a basic pattern. The body diameter of the particle is a maximum of 3 mm, and the specification does not teach tapering of the pins. US Patent 15 No. 5,458,970 teaches shaped particles comprising deformed fibers in which the fiber is a zinc oxide whisker having a plurality of needle-like portions being maximally 0.1mm in length and extending from its nucleus portion.

20 US Patent No. 5,258,028 is directed to an injectable micro-implantation system utilizing textured micro particles maximally 3mm in diameter and having a number of outwardly projecting pillar members.

25 WO 94/08912 teaches an aggregate having six arms in which the arms are generally obelisk-shaped and have four sides each.

The method of making a product from a form of hydrated calcium sulfate is known. Conversion of gypsum powders to plaster of Paris powders (calcination) is well established, and the rehydration of the plaster 30 of Paris powder to convert to gypsum is also well known.

US Patent No. 5,320,677 describes the formation of a composite material of gypsum and a stronger component, such as wood fibers. The technique then dehydrates the mix and rehydrates it. The method is a way of mixing in and setting the wood fibers within calcium sulfate. A target application for such a method is the preparation of wallboard.

German Patentschrift DE 3732281 C2 relates to the process of compaction of gypsum, and the subsequent dehydration/rehydration at an elevated temperature and pressure for the purpose of forming a consolidation solid to create a more compact form of waste material for easier disposal.

In the art of making shaped particles of calcium sulfate there is lacking a process to form a small, detailed part with high density, strength and resistance to dissolution in water. A major complication to this processing is that calcium sulfate needs to be maintained below temperatures of about 150°C-300°C and especially below 500°C to avoid thermal decomposition to an insoluble anhydrous form which is difficult to rehydrate. The low degradation temperature eliminates the possibilities of a traditional, high-temperature sintering process to sinter the calcium sulfate particles to one another, thereby strengthening and consolidating the material. Sintering is herein defined as the bonding of powdered particles by solid state diffusion.

Typical forming procedures for calcium sulfate are dry powder pressing (as in pharmaceutical tableting) or casting of a plaster of Paris slurry. The wall board industry uses various wet forming processes to compact slurries of plaster of Paris into large sheets.

UK Patent 2 205 089 A is directed to a process for the production of calcium sulphate alpha-hemihydrate. The calcium sulphate dihydrate is molded, introduced to an autoclave, and in the presence of an adequate

amount of water in the pores, the crystal growth and crystal form of the calcium sulphate alpha-hemihydrate is controlled by maintaining a temperature between 110°C and 180°C and regulating the atmospheric pressure inside the autoclave.

5

It is an object of the present invention to provide a shaped particle for use in treating a bone deficiency wherein said particle is shaped for use in an array of particles interlocked with one another, comprising a center portion and at least four tapered extremities projecting from said center portion wherein said projections provide for interstitial spaces between adjacent extremities, each extremity having a base attached at said center portion, an opposite point, a length, and a circular transverse cross-sectional configuration, wherein said interstitial spaces of one said particle will accept at least one extremity of an adjacent said particle to facilitate interlocking of adjacent particles in said array.

10
15

In specific embodiments of the present invention the particle has at least three in a plane and the particle has six extremities. In other specific embodiments the particle is comprised of a material selected from the group consisting of ceramic, bioactive glass, polymer, polymer/ceramic composite, and polymer/glass composite. In a preferred embodiment the particle is comprised of ceramic and more preferred is comprised of a calcium salt such as calcium sulfate, calcium carbonate, calcium phosphate and calcium tartarate, but most preferable is of calcium sulfate, or gypsum.

20
25

In another embodiment of the present invention the particle is comprised of a polymer such as polypropylene, polylactic acid, polyglycolic acid and polycaprolactone.

30

In a preferred embodiment the particle has a diameter of about 3-10 millimeters, more preferred is 4-8 millimeters, and most preferred is 6 millimeters.

5 It is another object of the present invention to provide an array which contains multiple particles wherein said multiple particles are in a mixture of particles comprised of different materials. In a specific embodiment the different materials are selected from the group consisting of ceramic, such as a calcium salt, bioactive glass, polymer, polymer/ceramic composite,
10 and polymer/glass composite.

In an additional object of the present invention there is a shaped particle for the treatment of a bone deficiency wherein said treatment is selected from the group consisting of augmentation of bone, repair of
15 bone, replacement of bone, improvement of bone, strengthening of bone and healing of bone. In a specific embodiment the bone deficiency is selected from the group consisting of a fracture, break, loss of bone, weak bone, brittle bone, hole in bone, void in bone, disease of bone and degeneration of bone.

20

In an additional embodiment the disease is selected from the group consisting of osteoporosis, Paget's disease, fibrous dysplasia, osteodystrophia, periodontal disease, osteopenia, osteopetrosis, primary hyperparathyroidism, hypophosphatasia, fibrous dysplasia, osteogenesis
25 imperfecta, myeloma bone disease and bone malignancy.

In a specific embodiment the array of the present invention has interlocking of adjacent particles which provides adequate porosity to allow ingrowth from a host bone.

30

In a specific embodiment the porosity is between 40-80%. In a more preferred embodiment the porosity is between 60 and 80%.

In another object of the present invention there is an array of shaped particles wherein said array comprises a plurality of shaped particles comprising one or more shaped particles from the group consisting of a
5 first shaped particle comprising a center portion and at least four tapered extremities projecting from said center portion wherein said projections provide for interstitial spaces between adjacent extremities, each extremity having a base attached at said center portion, an opposite point, a length, and a circular transverse cross-sectional configuration, wherein said
10 interstitial spaces of one said particle will accept at least one extremity of an adjacent said particle to facilitate interlocking of adjacent particles in said array of shaped particles; a second shaped particle comprising a center portion, at least two noncurved extremities, and at least three curved extremities projecting from said center portion wherein said
15 projections provide for interstitial spaces between adjacent extremities, each extremity having a base attached at said center portion, an opposite point, a length, and a transverse cross-sectional configuration, wherein said interstitial spaces of one said particle will accept at least one
20 extremity of an adjacent said particle to facilitate interlocking of adjacent particles in said array; and a third shaped particle comprising a multi-ring structure having at least four curved projections wherein said projections provide for interstitial spaces between adjacent said projections, and wherein said projections facilitate interlocking of adjacent particles in said array.

25

In an additional object of the present invention is a shaped particle for use in treating a bone deficiency wherein said particle is shaped for use in an array of particles interlocked with one another, comprising a multi-ring structure having at least four curved projections wherein said
30 projections provide for interstitial spaces between adjacent said projections, and wherein said projections facilitate interlocking of adjacent particles in said array. In specific embodiments the angles between the

curved projections are equal. In another embodiment the shaped particle is composed of a polymer such as polypropylene, polylactic acid, polyglycolic acid and polycaprolactone or a polymer/ceramic composite or polymer/glass composite.

5

In another embodiment of the present invention is a a composition for use in treating a bone deficiency comprising a suspension material; and a shaped particle from the group consisting of a first shaped particle comprising a center portion and at least four tapered extremities projecting from said center portion wherein said projections provide for interstitial spaces between adjacent extremities, each extremity having a base attached at said center portion, an opposite point, a length, and a circular transverse cross-sectional configuration, wherein said interstitial spaces of one said particle will accept at least one extremity of an adjacent said particle to facilitate interlocking of adjacent particles in said array of shaped particles; a second shaped particle comprising a center portion, at least two noncurved extremities, and at least three curved extremities projecting from said center portion wherein said projections provide for interstitial spaces between adjacent extremities, each extremity having a base attached at said center portion, an opposite point, a length, and a transverse cross-sectional configuration, wherein said interstitial spaces of one said particle will accept at least one extremity of an adjacent said particle to facilitate interlocking of adjacent particles in said array; and a third shaped particle comprising a multi-ring structure having at least four curved projections wherein said projections provide for interstitial spaces between adjacent said projections, and wherein said projections facilitate interlocking of adjacent particles in said array.

In specific embodiments the suspension material is selected from the group consisting of starch, sugar, glycerin, blood, bone marrow, autograft material, allograft material, fibrin clot and fibrin matrix or the suspension material is a binder capable of forming a gel such as collagen derivative,

cellulose derivative, methylcellulose, hydroxypropylcellulose, hydroxypropylmethyl cellulose, carboxymethylcellulose, fibrin, and a biological adhesive such as cryoprecipitate.

5 In another object of the present invention the suspension material further comprises a biological agent, such as a growth factor, an antibiotic, a strontium salt, a fluoride salt, a magnesium salt, a sodium salt, a bone morphogenetic factor, a chemotherapeutic agent, a pain killer, a bisphosphonate and a bone growth agent. In a specific embodiment the
10 growth factor is selected from the group consisting of platelet derived growth factor (PDGF), transforming growth factor β (TGF- β), insulin-related growth factor-I (IGF-I), insulin-related growth factor-II (IGF-II), fibroblast growth factor (FGF), beta-2- microglobulin (BDGF II) and bone morphogenetic protein (BMP). In a specific embodiment the antibiotic is
15 selected from the group consisting of tetracycline hydrochloride, vancomycin, cephalosporins, and aminoglycosides such as tobramycin and gentamycin.

 In another specific embodiment the bone morphogenetic factor is
20 selected from the group consisting of proteins of demineralized bone, demineralized bone matrix (DBM), bone protein (BP), bone morphogenetic protein (BMP), osteonectin, osteocalcin and osteogenin. In an additional specific embodiment the chemotherapeutic agent is selected from the group consisting of cis-platinum, ifosfamide, methotrexate and doxorubicin
25 hydrochloride. In an additional specific embodiment the pain killer is selected from the group consisting of lidocaine hydrochloride, bipivacaine hydrochloride, and non-steroidal anti-inflammatory drugs such as ketorolac tromethamine.

30 In another object of the present invention the composition further includes a clotting factor composition. In a specific embodiment the clotting factor composition comprises fibrinogen, thrombin and Factor XIII.

In an additional object of the present invention there is a method to treat a bone deficiency comprising the step of applying a shaped particle to a bone deficiency wherein said shaped particle is selected from the

5 group consisting of a first shaped particle comprising a center portion and at least four tapered extremities projecting from said center portion wherein said projections provide for interstitial spaces between adjacent extremities, each extremity having a base attached at said center portion, an opposite point, a length, and a circular transverse cross-sectional

10 configuration, wherein said interstitial spaces of one said particle will accept at least one extremity of an adjacent said particle to facilitate interlocking of adjacent particles in said array of shaped particles; a second shaped particle comprising a center portion, at least two noncurved extremities, and at least three curved extremities projecting

15 from said center portion wherein said projections provide for interstitial spaces between adjacent extremities, each extremity having a base attached at said center portion, an opposite point, a length, and a transverse cross-sectional configuration, wherein said interstitial spaces of one said particle will accept at least one extremity of an adjacent said

20 particle to facilitate interlocking of adjacent particles in said array; and a third shaped particle comprising a multi-ring structure having at least four curved projections wherein said projections provide for interstitial spaces between adjacent said projections, and wherein said projections facilitate interlocking of adjacent particles in said array.

25

In another object of the present invention there is a method to treat a bone deficiency comprising the steps of combining a shaped particle with a suspension material wherein said particle is selected from the group consisting of a first shaped particle comprising a center portion and at

30 least four tapered extremities projecting from said center portion wherein said projections provide for interstitial spaces between adjacent extremities, each extremity having a base attached at said center portion,

an opposite point, a length, and a circular transverse cross-sectional configuration, wherein said interstitial spaces of one said particle will accept at least one extremity of an adjacent said particle to facilitate interlocking of adjacent particles in said array of shaped particles a second
5 shaped particle comprising a center portion, at least two noncurved extremities, and at least three curved extremities projecting from said center portion wherein said projections provide for interstitial spaces between adjacent extremities, each extremity having a base attached at said center portion, an opposite point, a length, and a transverse cross-
10 sectional configuration, wherein said interstitial spaces of one said particle will accept at least one extremity of an adjacent said particle to facilitate interlocking of adjacent particles in said array; and a third shaped particle comprising a multi-ring structure having at least four curved projections wherein said projections provide for interstitial spaces between adjacent
15 said projections, and wherein said projections facilitate interlocking of adjacent particles in said array; and applying said combination to a bone deficiency.

In another object of the present invention there is a kit for the
20 treatment of a bone deficiency comprising a suspension material; and multiple first shaped particles and multiple second shaped particles wherein said first and second particles are shaped for use in an array of particles interlocked with one another and wherein said particles are selected from the group consisting of a first shaped particle comprising a
25 center portion and at least four tapered extremities projecting from said center portion wherein said projections provide for interstitial spaces between adjacent extremities, each extremity having a base attached at said center portion, an opposite point, a length, and a circular transverse cross-sectional configuration, wherein said interstitial spaces of one said
30 particle will accept at least one extremity of an adjacent said particle to facilitate interlocking of adjacent particles in said array of shaped particles; a second shaped particle comprising a center portion, at least two

noncurved extremities, and at least three curved extremities projecting from said center portion wherein said projections provide for interstitial spaces between adjacent extremities, each extremity having a base attached at said center portion, an opposite point, a length, and a
5 transverse cross-sectional configuration, wherein said interstitial spaces of one said particle will accept at least one extremity of an adjacent said particle to facilitate interlocking of adjacent particles in said array; and a third shaped particle comprising a multi-ring structure having at least four curved projections wherein said projections provide for interstitial spaces
10 between adjacent said projections, and wherein said projections facilitate interlocking of adjacent particles in said array.

In a specific embodiment the kit further comprises a biological agent. In another specific embodiment the kit further includes a clotting factor
15 composition, such as a composition comprising fibrinogen, thrombin and Factor XIII. In another embodiment the kit further comprises a bowl container for said multiple first and multiple second particles and a delivery tool. In a specific embodiment the delivery tool is selected from the group consisting of a spoon, a spatula, a scoop, a tweezer, forceps, a knife, a
20 hemostat, a syringe, a pipette, a cup and a ladle. In another specific embodiment the bowl container is used for mixing said multiple first and multiple second particles and a suspension material. In another specific embodiment the bowl container is used for mixing said multiple first and multiple second particles, said suspension material, and a biological agent.

25

In another embodiment there is a shaped particle for use in treating a bone deficiency wherein said particle is shaped for use in an array of particles interlocked with one another, comprising a center portion; at least two noncurved extremities; and at least three curved extremities projecting
30 from said center portion wherein said projections provide for interstitial spaces between adjacent extremities, each extremity having a base attached at said center portion, an opposite point, a length, and a

transverse cross-sectional configuration, wherein said interstitial spaces of one said particle will accept at least one extremity of an adjacent said particle to facilitate interlocking of adjacent particles in said array.

5 In another embodiment there is a method for manufacturing a shaped particle of calcium sulphate dihydrate comprising the steps of making a shaped particle of calcium sulphate dihydrate; heating said particle; and applying water to said particle.

10 In an additional embodiment there is a method for manufacturing a shaped particle of calcium sulphate dihydrate comprising the steps of making a shaped particle of calcium sulphate dihydrate; heating in the presence of pressure and moisture said particle of calcium sulphate dihydrate to convert said particle to α -calcium sulphate hemihydrate
15 partially or in full; and applying water to said particle to convert said α -calcium sulphate hemihydrate to said calcium sulphate dihydrate.

Other and further objects, features and advantages would be apparent and eventually more readily understood by reading the following
20 specification and by reference to the company drawing forming a part thereof, or any examples of the presently preferred embodiments of the invention are given for the purpose of the disclosure.

Figure 1 is a drawing of a preferred six-armed shaped particle of the
25 invention.

Figure 2 is a drawing of an array of interlocked six-armed shaped particles of the invention.

30 Figure 3A through Figure 3D are drawings of a five-armed shaped particle of the invention. Figure 3A is a top view of the particle. Figure 3B

is a view of the particle from an elevated side reference. Figure 3C is a front view of the particle. Figure 3D is a right view of the particle.

Figure 4A through 4D are drawings of a six-armed shaped particle of the invention having flat tips. Figure 4A is a top view of the particle. Figure 4B is a view of the particle from an elevated side reference. Figure 4C is a front view of the particle. Figure 4D is a right view of the particle.

Figure 5A through 5D are drawings of a six-armed shaped particle of the invention having rounded tips. Figure 5A is a top view of the particle. Figure 5B is a view of the particle from an elevated side reference. Figure 5C is a front view of the particle. Figure 5D is a right view of the particle.

Figures 6A through 6D are drawings of a shaped particle of the invention having an interlocked ring structure. Figure 6A is a top view of the particle. Figure 6B is a view of the particle from an elevated side reference. Figure 6C is a front view of the particle. Figure 6D is a right view of the particle.

Figures 7A through 7D are drawings of different views of a six-armed shaped particle of the invention having a propeller-like structure.

Figure 8A through Figure 8D are drawings of a six-armed shaped particle of the invention. Figure 8A is a top view of the particle. Figure 8B is a view of the particle from an elevated side reference. Figure 8C is a front view of the particle. Figure 8D is a right view of the particle.

The term "bone deficiency" as used herein is defined as a bone defect such as a break, fracture, void, diseased bone, loss of bone, brittle bone or weak bone, injury, disease or degeneration. Such a defect may be the result of disease, surgical intervention, deformity or trauma. The degeneration may be as a result of progressive aging. Diseased bone

could be the result of bone diseases such as osteoporosis, Paget's disease, fibrous dysplasia, osteodystrophia, periodontal disease, osteopenia, osteopetrosis, primary hyperparathyroidism, hypophosphatasia, fibrous dysplasia, osteogenesis imperfecta, myeloma
5 bone disease and bone malignancy. The bone deficiency may be due to a disease or condition, such as a disease which indirectly adversely affects bone. Furthermore, the bone malignancy being treated may be of a primary bone malignancy or may be metastatic, originating from another tissue or part of the body.

10

The term "ceramic" as used herein is defined as any non-metallic, non-organic engineering material. An example of such a material is hydroxylapatite, calcium sulphate, alumina or silica.

15

The term "gypsum" as used herein is defined as calcium sulfate in the stable dihydrate state ($\text{CaSO}_4 \cdot 2\text{H}_2\text{O}$) and includes the naturally occurring mineral, the synthetically derived equivalents, and the dihydrate material formed by the hydration of calcium sulfate hemihydrate ($\text{CaSO}_4 \cdot \frac{1}{2}\text{H}_2\text{O}$)(Plaster of Paris) or anhydrite calcium sulphate. The
20 gypsum may be obtained from commercially available sources.

25

The term "tapered" as used herein is defined as referring to an extremity of a shaped particle wherein the width of one end of the extremity is different in size from the width of another end of the extremity. That is, the tapering of the extremity may be outward away from the center of the particle or may be inward toward the center of the particle.

30

An object of the present invention is a shaped particle as part of three-dimensional interlocking array of particles to be utilized in bone graft. A skilled artisan is aware that the particles may be utilized with inductive graft in which the graft actively facilitates, either directly or indirectly, bone growth. In addition or alternatively, the particles may be utilized for a

conductive graft in which the graft is conducive to bone growth but does not actively or directly facilitate it. In a specific embodiment conductive graft utilizes shaped particles made from a ceramic, polymeric, glass material, a polymeric/glass, or a polymeric/ceramic material. In another

5 specific embodiment the particles for conductive graft are augmented with a biological agent. The material of the particle will be a biocompatible ceramic or glass that may or may not eventually resorb or degrade within the body as the bone heals and fills the bone void or improves the bone deficiency. The particles will be of an appropriate size such that several

10 individual granules will be used to fill a small void while many can be used to fill larger voids. The three-dimensional structure will allow the granules to fill a volume and interlock with each other. In addition, the particles will be able to interlock with bone. The interlocking will enable the particles to support some mechanical forces while maintaining stability and assist in

15 bone healing. The interlocking feature makes it possible for the particles to resist some shear forces, unlike commercially available products. It will also help to resist migration away from the implant site. The particles will be able to fill odd bone defect shapes and sizes without necessarily needing to carve a larger block to the approximate shape/size. The

20 interlocked particles also provide the ability for the entire implant to behave mechanically more like a single block as compared to current granular products. The shapes would be such that a collection of these particles do not aggregate into a solid, packed volume but instead leave an open, interconnected porosity that is beneficial for bone healing. It is preferred

25 that the shape of the particles and/or the array of the shaped particles allow the engineering or prediction of a specific porosity. For example, the particles can be shaped to have such a design as to allow 40-80% porosity upon agglomeration.

30 The purpose of having shaped particles is two-fold. First, the capability to interlock provides resistance to shear forces and helps to increase the stability when the graft is packed into a defect. Second,

porosity needs to be maintained when the shaped particles are interlocked. It is known in the art that new bone growth can ingress into pores ranging from 100-400 microns in size. The targeted total porosity will range from 20% to 80%, which means that the array of interlocking
5 shaped particles of the invention will retain open spaces of 20-80% of a specific volume of an array. It is important that a graft material provide adequate porosity to allow ingrowth from the host bone. Alternatively, the material must resorb or degrade away to allow for bone replacement. The preferred embodiment is the combination of both of these properties.

10

The tapering of the extremities of the shaped particles improves manufacturability, maximizes the open space between the extremities, and provides greater mechanical stability in, for instance, the preferred shaped particle of Figure 1 because the arms are thicker as you get closer to the
15 central body, which distributes loads over more mass of material.

The shaped particles of the present invention are illustrated in the figures. Figure 1 shows a shaped particle (10) having an extremity (20), and in a preferred embodiment the particle has six extremities. In a
20 preferred embodiment at least three of the extremities are in a common plane. The extremities are tapered outwardly along the length (30) of the extremity so that the base (40) of the extremity is wider than the tip (50) of the extremity. In a preferred embodiment the tip (50) of the extremities are rounded. The particle has an interstitial space (60) between the adjacent
25 extremities (20). In a preferred embodiment the radius of curvature of the tip (50) of an extremity (20) is about 0.5mm and the radius of curvature of the interstitial space (60) between adjacent extremities is about 0.5mm. The preferred width of the entire particle is about 3-10 mm, and more preferred 4-8mm, and most preferred is 6mm. The preferred width of a
30 base (40) of an extremity (20) is about 1.85mm, the preferred width of a tip (50) of an extremity is about 1.19mm, and the preferred length (30) of an extremity (20) is about 3mm. In a preferred embodiment the angles

between any of the adjacent extremities (20) are approximately equal. A skilled artisan is aware that shaped particles may be used which are greater in size than these measurements or smaller in size than these measurements depending on the relevant application and bone deficiency.

5 It is preferred to keep the size of the particle small relative to the wound site so that it will take many particles to fill the defect rather than one.

Figure 2 illustrates an array of shaped particles of the invention wherein the extremities (20) of adjacent particles (10) are interlocked.

10

Figures 3A through 3D illustrate different views of a specific embodiment wherein a five-armed shaped particle (100) is an object of the invention. In a preferred embodiment of a five-armed shaped particle at least three extremities lie in a plane. An extremity (110) is tapered inwardly along its length (120) wherein the base (130) of the extremity (110) is more narrow in width than the tip (141) of the extremity (110). An interstitial space (150) is present between adjacent extremities. The tips (141) of the extremities (110) are rounded in a specific embodiment.

15

Figures 3B through 3D illustrate that in a specific embodiment the tips (158 and 159) of two extremities (160 and 170, respectively) which are situated about 180 degrees from one another are generally more conical in shape than the tips (141) of the extremities (110). The extremities (160 and 170) taper outwardly where the base (161 and 171, respectively) is wider than the tips (158 and 159).

20

25

Figures 4A through 4D illustrate different views of a specific embodiment wherein a six-armed shaped particle (300) is an object of the invention. In a preferred embodiment at least three extremities lie in a plane. An extremity (310) is tapered inwardly along its length (320) wherein the base (330) of an extremity (310) is more narrow in width than the tip (340) of the extremity (310). An interstitial space (350) is present between adjacent extremities. The tips (340) have a generally flat surface.

30

Figures 4B through 4D show the tips (360 and 361) of two extremities (370 and 380, respectively) are generally more conical in shape than the tips (340) of the extremities (310) and are situated about 180 degrees from one another in the particle (300).

5

Figures 5A through 5D illustrate different views of a specific embodiment wherein a six-armed shaped particle (400) is an object of the invention. In a preferred embodiment at least three extremities lie in a plane. An extremity (410) is tapered inwardly along its length (420) wherein the base (430) of an extremity (410) is more narrow in width than the tip (440) of the extremity (410). An interstitial space (450) is present between adjacent extremities. The tips (440) of the extremities (410) have a generally rounded surface. Figures 5B through 5D show the tips (460 and 461) of two extremities (470 and 480, respectively) are generally more conical in shape than the tips (440) and are situated 180 degrees from one another in the particle (400).

It is preferred that the shaped particles represented in Figures 4 and 5 are made from a polymer, polymer/ceramic composite, or polymer/glass composite. The tapering inwardly of the extremities (310 and 410) allows these shaped particles to "snap-fit" into an adjacent particle.

Figures 6A through 6D illustrate different views of a specific embodiment of the present invention wherein a shaped particle (500) is similar to two interlocked rings positioned at about 90 degrees from one another. Interstitial spaces (510) allow interlocking of the rings (520), or curved projections, of an adjacent particle. The preferred composition material of this structure is a polymer, a polymer/glass composite or a polymer/ceramic composite. In a preferred embodiment the structure is relatively compliant in comparison to a ceramic-based structure. A preferred diameter of the entire particle (500) is about 6 mm, and a preferred diameter of the ring (520) component of the structure is about

1mm. The maximum number of rings would be such that the surface area of the rings should not be more than 50% of the surface area of the encompassed sphere - otherwise the parts would not interlock or nest with each other. Using this as a starting point, then the diameter of the solid structure of the ring (as an example at about 1 mm) becomes a factor. As that diameter decreases the number of possible rings increases.

In the mathematical relationship between a radius of a "spherical" particle, r , a thickness or diameter of rings, d , and a number of rings, n , a surface area of a sphere is $4\pi r^2$ and a surface area of the interlocking rings is $2\pi rdn$. The objective is that the surface area of the rings is less than or equal to 50% of the surface area of a sphere. The mathematical relationship can be described as

$$2\pi rdn \leq 0.50 (4\pi r^2), \text{ or}$$

$$2\pi rdn \leq 2\pi r^2, \text{ or}$$

$$dn \leq r$$

Figures 7A through 7D illustrate a specific embodiment of the present invention wherein a shaped particle (600) is similar to a propeller. Interstitial spaces (610) allow interlocking of the extremities (620) of the particle. The length (615) of an extremity (620) is curved generally as in a propeller arm. The composition material of this structure is a ceramic, polymer, bioglass, polymer/ceramic composite, or polymer/glass composite. In a preferred embodiment the structure is relatively compliant in comparison to a ceramic-based structure. A preferred diameter of the entire particle (600) is about 6 mm, and a preferred diameter of the extremities (620) component of the structure is about 1mm. The extremities (630 and 631), particularly as shown in Figure 7D, are generally conical in shape, having a wider base (640 and 641, respectively) tapering along the length (650 and 651, respectively) of the extremity to a narrower tip (660 and 661, respectively). The extremities (630 and 631) are positioned about 180 degrees relative to each other.

Figures 8A through 8D illustrate different views of a specific embodiment wherein a six-armed shaped particle (700) is an object of the invention. In a preferred embodiment of a six-armed shaped particle at least three extremities lie in a plane. An extremity (710) is tapered inwardly along its length (720) wherein the base (730) of the extremity (710) is more narrow in width than the tip (741) of the extremity (710). An interstitial space (750) is present between adjacent extremities. The tips (741) are rounded in a specific embodiment. Figures 8B through 8D illustrate that in a specific embodiment the tips (702 and 704) of two extremities (760 and 770, respectively) which are situated about 180 degrees from one another are generally more conical in shape than the tips (741) of the extremities (710). The extremities (760 and 770) taper outwardly where the base (761 and 771, respectively) is wider than the tips (702 and 704, respectively).

A skilled artisan is aware that the surface to volume ratio of the shaped particle of the present invention has influence upon several factors, including the intended application of the bone graft, which dictates the size of the particle needed and the dissolution rates, strength and manufacturability.

Example 1 - Testing of Shaped Particles

The assessment of the shaped particles was based on two tests designed to address interlocking of the particles and application to a clinical-type case.

- A) 'Slump' test—measure the ability of a pile of bone graft granules to maintain its height before and after vibration.
- B) Push-thru test—measure the resistance to push-thru of an agglomeration of bone graft granules through a cylindrical defect in a

porous foam block, which is a lab model used for human cancellous bone.

The goal was to determine which of the designs provided the most interlocking that was also an improvement over a design comparable to a commercially available tablet-shaped product.

Equipment:

A) 'Slump' test

Tablets, 28 mL

Shaped particle designs, 28mL of each
100mL graduated cylinder (EXAX, No. 20025)

Scale (Mettler Toledo, AT261)

Vibrating, electronic pencil (Ideal Industries, Electric Marker)

Funnel (half angle 28°)

Cuplike container (half angle 12°, base diameter 1.125")

Ring stand

Height gage (Mitutuyo, No. 192-112)

Base plate (1x6x6 inch cold-rolled steel)

Watch with second hand

B) Push-Thru test

Tablets, 50mL

Shaped particle designs, 50mL of each
Tinius-Olsen screw driven mechanical test frame and

2000 recorder

Porous foam block (General Plastics Manufacturing Company, FR3703)

Polyethylene plunger and stopper

Image pro Plus Software (Media Cybernetics, V 3.0.1)

10

Three different shaped particles of the present invention (Six-armed shaped particle, flared to bulb at end of arms of X-Y plane (Figure 8); Five-armed shaped particle, flared to bulb at end of arms in X-Y place (Figure 3); Six-armed shaped particle, tapered straight to end of arms in all directions (Figure 1); and one tablet-shaped geometry similar to commercially available products. The shaped particle designs were manufactured using clay formulation "50-dry". SLA molds were used to form the design prototypes. The components were all made similarly,

though slightly different processing parameters were used with each to insure proper drying and mold release, as follows:

1. Stereo lithographic models (SLA) were made of molds for each of the three designs.
- 5 2. SLA molds were washed and dried.
3. Lubricant was applied to the surface of the SLA molds. Excess was removed with a clean cloth and compressed air.
 - A. Two lubricants from Slide Products Inc. (Wheeling, IL) were used: 42612N, 44712G
 - 10 B. Pam® (International Home Foods, Parsippany, NJ) was used as another lubricant
4. Clay formula 50-dry (81.6% gypsum, 1.1% carboxymethyl cellulose, 4.1% glycerin, 13% water) was rolled into sheets (about 1 mm thick), big enough to cover the cavities in the molds.
 - 15 • Gypsum: FG-200, from BPB, Newark, United Kingdom
 - carboxymethyl cellulose: 7HF, from Hercules, Wilmington, DE
 - Glycerine, USP: GX-195-1, from EM Science, Gibbstown, NJ
5. The mold halves were closed together and compacted using about 4000 lbs. of force.
- 20 6. The molds were heated in a microwave oven to dry the water from the parts.
 - A. Six-armed shaped particle, flared to bulb at the ends of arms in X-Y plane heated for 4 min. at about 30% power.
 - B. Five-armed shaped particle X, flared to bulb at the ends of arms
25 in X-Y plane heated for 4:25 min. at about 30% power.
 - C. Six-armed shaped particle, straight, tapered arms, heated for 3:50 min. at about 30% power.
7. The molds were allowed to cool for approximately one minute.
8. The parts were removed from the mold and trimmed of any flashing
30 using an Exacto knife.
9. The parts were dried in a vacuum dessiccator for several hours prior to further testing.

Slump test

The slump test was conducted first since it was non-destructive.

- 5 Equal volumes (28mL) of each shaped particle design and the tablet samples were measured using a 100mL graduated cylinder. These equal volumes were weighed to determine the mass of material present.

- 10 The test begins by pouring the entire volume of individual shaped particle designs into a starting container. Either a funnel (half angle 28°) or a cuplike container (half angle 12° with a 1.125 inch flat base) was used to contain the shaped bone graft particles and provide a starting shape for the pile. The container was then inverted and placed on a base through which a vibration was applied for five seconds using an electronic,
15 vibrating pencil. The vibration was used to settle the shaped bone graft particles into the container of choice and pre-pack them to that shape. Following the vibration, the container was carefully removed. A height gage was used to measure the initial height of the pile. Vibration was then applied to the base plate, causing the pile to settle further. The height
20 gage was used again to measure this new height. The highest particle/tablet was used as the height in all cases. This test was repeated ten times for each design using each of the two containers (funnel and cuplike container). From the data a difference in heights and the percentage change in heights (relative to the initial height of the pile) were
25 calculated.

- Table 1 shows the mass data collected for the three shaped particle designs and the tablet geometry. The mass shown is for 28mL of particles, as measured in a 100mL graduated cylinder. One data point
30 was collected for each design.

Mass and mass per volume are important and related to the dissolution time and the porosity of the agglomerated granules. If all parameters were equal (material, density, surface-area-to-volume ratios, etc.) it would be expected that the more mass per volume, the lower would be the porosity of the agglomerate and the longer duration it would have before dissolution. The dissolution rate would determine how much material would disappear per unit of time and may also be influenced by the surface-area-to-volume ratio and the material.

Sample	Mass per 28 mL of granules
A) Six-armed shaped particle, flared to bulb at end of arms of X-Y plane	17.2175
B) Five-armed shaped particle, flared to bulb at end of arms in X-Y place	20.2567
C) Six-armed shaped particle, tapered straight to end of arms in all directions	21.2140
D) Tablet geometry	31.3437

10

Table 2 shows the summarized results for the slump tests performed on each of the different sample geometries using the funnel for a starting form. Each sample was measured ten times. It was proposed that maximizing the starting height and the height after vibration and minimizing the change in height and percent change in height were the ideal cases. The best value for the shaped particle designs tested for each parameter is in bold. The tablets did not form a pile (tablets fell to only one or two layers high) when the supporting container was removed, qualitatively indicating poor interlocking relative to other samples.

20

Table 2: Summarized results for the slump tests using the funnel for starting form.

Sample	Starting height, H1 (inches)	Height after vibration, H2 (inches)	Change in height, Δ (inches)	Percent change in height, relative to starting height (inches)
A) Six-armed shaped particle, flared to bulb at end of arms of X-Y plane (n=10)	1.275 ± 0.109	0.821 ± 0.070	0.454 ± 0.147	35.138 ± 8.072
B) Five-armed shaped particle, flared to bulb at end of arms in X-Y plane (n=10)	1.223 ± 0.161	0.806 ± 0.069	0.418 ± 0.146	33.350 ± 8.675
C) Six-armed shaped particle, tapered straight to end of arms in all directions (n=10)	1.114 ± 0.158	0.829 ± 0.054	0.285 ± 0.128	24.734 ± 7.955
D) Tablet geometry, (n=10)	0.662 ± 0.055	0.578 ± 0.032	0.084 ± 0.056	12.342 ± 6.981

Funnel

6-arm/bulb arm:			
	H1 (inches)	H2 (inches)	Δ
T1	1.22	0.885	0.335
T2	1.56	0.738	0.822
T3	1.28	0.81	0.470
T4	1.18	0.76	0.420
T5	1.18	0.75	0.430
T6	1.3	0.790	0.51
T7	1.283	0.80	0.483
T8	1.121	0.926	0.195
T9	1.255	0.823	0.432
T10	1.285	0.929	0.356

5- arm:			
	H1 (inches)	H2 (inches)	Δ
T1	1.344	0.093	0.441
T2	1.185	0.830	0.355
T3	1.180	0.75	0.430
T4	1.150	0.801	0.349
T5	1.760	0.89	0.470
T6	1.39	0.787	0.603
T7	1.103	0.656	0.447
T8	1.472	0.823	0.649
T9	0.959	0.812	0.147
T10	1.090	0.806	0.284

6 arm/straight arm:			
	H1	H2	Δ
T1	1.132	0.890	0.242
T2	1.269	0.862	0.407
T3	1.219	0.801	0.418
T4	0.93	0.786	0.144
T5	0.967	0.849	0.118
T6	1.049	0.791	0.258
T7	1.050	0.789	0.261
T8	1.451	0.93	0.521
T9	1.020	0.829	0.191
T10	1.053	0.760	0.293

Tablet:			
	H1	H2	Δ
1	0.634	0.576	0.058
2	0.670	0.641	0.029
3	0.681	0.543	0.138
4	0.618	0.540	0.078
5	0.637	0.559	0.078
6	0.690	0.574	0.116
7	0.644	0.594	0.005
8	0.613	0.551	0.062
9	0.799	0.591	0.208
10	0.635	0.609	0.026

Table 3 shows the summarized results for the slump tests performed using the cuplike container for a starting form. As with the slump test using the funnel for a starting container, maximizing the start height and the height after vibration and minimizing the change in height and percent change in height were the ideal cases. The best value for the shaped particle designs tested in each column in bold.

Cuplike Container

Table 3: Summarized results for the slump tests using the cuplike container for starting form.

Sample	Starting height (inches)	Height after vibration (inches)	Change in height (inches)	Percent change in height, relative to starting height (inches)
A) Six-armed shaped particle, flared to bulb at end of arms of X-Y plane (n=10)	0.970 ±0.056	0.860 ±0.027	0.111 ±0.051	11.184 ±4.696
B) Five-armed shaped particle, flared to bulb at end of arms in X-Y plane (n=10)	0.997 ±0.051	0.844 ±0.056	0.153 ±0.063	15.194 ±5.894
C) Six-armed shaped particle, tapered straight to end of arms in all directions (n=10)	0.907 ±0.062	0.744 ±0.052	0.133 ±0.067	14.435 ±6.854
D) Tablet geometry, (n=10)	0.516 ±0.049	0.441 ±0.040	0.075 ±0.030	14.361 ±5.077

10

Actual test data are as follows.

6 Arm/Bulb Arm			
	H1	H2	Δ
1	1.070	.870	0.20
2	0.975	.826	0.149
3	1.005	.880	0.125
4	0.891	.849	0.042
5	0.905	.821	0.084
6	0.951	.875	0.076
7	0.949	.886	0.063
8	0.940	.875	0.065
9	1.038	.890	0.148
10	0.979	.826	0.153

5-arm:			
	H1	H2	Δ
1	1.005	0.798	0.207
2	0.935	0.815	0.055
3	0.934	0.880	0.054
4	1.032	0.823	0.209
5	1.020	0.894	0.126
6	0.994	0.804	0.190
7	1.062	0.856	0.206
8	1.030	0.802	0.228
9	0.915	0.801	0.114
10	1.041	0.968	0.073

Tablet:			
	H1	H2	Δ
1	0.466	0.411	0.055
2	0.469	0.419	0.05
3	0.560	0.471	0.089
4	0.590	0.472	0.118
5	0.511	0.470	0.041
6	0.540	0.40	0.14
7	0.467	0.412	0.055
8	0.457	0.379	0.078
9	0.540	0.406	0.134
10	0.562	0.492	0.070

Data from the two slump tests were contradictory. From the test using the funnel for support and shape of the initial pile, the six-armed shaped particle with simple tapers was seen to be better than the other designs. In the test using the cuplike container the six-armed shaped particle with the arms in the X-Y plane flared to bulbs was seen as the better design.

Push-thru test

10

The push-thru test was a mechanical test performed using a Tinius-Olsen (Willow Grove, PA) screw-driven mechanical test frame. Once tested using this procedure, the sample parts and the defects in the porous blocks were considered to be damaged and not valid for additional testing.

15

A polyethylene stopper was placed into the bottom of the pre-drilled, 0.750" hole (thru) in the porous foam block. Then, a volume (approximately 8mL) of shaped particle is added to the hole and the top plunger is inserted. The correct amount of shaped particles are added when the plunger sits such that the fill mark just shows above the level of the top of the porous foam block. The test block with plunger, stopper and shaped particles are then transferred to the test frame. The part to be tested is situated such that the stopper is over a solid block to temporarily block the shaped particle and stopper from falling through. A pre-load of ten pounds of force is then applied at a rate of 0.1 inches/minute. The pre-load is then removed and the stopper is positioned over an opening such that the plunger can press against the shaped particles and the majority of resistance comes from frictional forces between the shaped particle and the shaped particle and the walls. Additional resistance is expected between the stopper/plunger and the walls, but this should be small and consistent in all tests performed. Load is reapplied at a rate of

20
25
30

0.1 inches/minute until the resisting load drops to zero and the granules are gone from the test block. Data is recorded using a load/displacement graph. This test was repeated five times for each of the three shaped particle designs and three times for the tablet geometry.

5

The data was analyzed using Image Pro Plus software (Media Cybernetics) to determine the area under the curves. The assumption was made that the load and displacement axes were both to the same scale (displacement) which means that the value calculated for area under the curve is not truly energy. The values of the area under the load-displacement curve are useful for comparing one against the other and to show relatively which design required more energy to force the granules through the block.

15 Table 4 shows the summarized results for the push-thru testing on each of the different geometries.

Table 4: Summarized results for the push-thru tests.		
Sample	Area under load vs Displacement (in²)**	Percentage vs six-armed, tapered
A) Six-armed shaped particle, flared to bulb at end of arms of X-Y plane (n=5)	0.057 ±0.015	0.655
B) Five-armed shaped particle, flared to bulb at end of arms in X-Y plane (n=5)	0.058 ±0.009	0.667
C) Six-armed shaped particle, tapered to end of arms in all directions (n=5)	0.087 ±0.019	1.000
D) Tablet geometry, "OsteoSet®-like" shape (n=10)	0.003 ±0.003	0.034

**area under curve was measured using the Image Pro software package, with both axes (load and displacement) calibrated as inches. This is not a true energy measurement, but serves for comparative purposes.

20

Maximizing the area under the load/displacement curve was ideal - indicating the most energy required to overcome resistance of interlocking and friction. The maximum value was found with the six-armed shaped particle that was tapered on all arms and is listed in bold in the table.

- 5 Difference in the push-thru resistance between this design and each of the other three designs was found to be statistically significant (student t-test, two tail, unequal variance, $p < 0.05$).

10 Observations during the testing showed that all three shaped particle designs resisted push-thru similarly - the granules interlocked with themselves and the walls of the foam block to resist the motion of the plunger through nearly the entire thickness of the test block. The tablet geometry did not offer much resistance, with only a short travel distance required before all of the granules fell out of the bottom of the test block.

15

The tested granules can be listed in order of decreasing mass per 28mL volume: tablet geometry, six-armed shaped particle with tapered arms, five-armed shaped particle, and six-armed shaped particle flared to bulb at the end of arms in X-Y plane.

20

The conclusions of the slump testing and push-thru testing are as follows:

25 Slump testing of the different designs was inconclusive. The test using the funnel (28° half angle) showed the six-armed shaped particle with tapered arms to be the best. The test using the cuplike container (12° half angle, 1.125" base) showed the six-armed shaped particle with X-Y plane arms flared to bulbs to be the best. It was also seen that the tablets behaved qualitatively worse compared to any of the shaped particle designs, failing to interlock and retain much of the original pile height.

30

Push-thru testing showed that the six-armed shaped particle with tapered arms offered the most resistance to push the granules all the way

through the porous foam test block. The other shaped particle designs both required about 1/3 less energy to push the granules through the same block. The tablets required only about 3% of the energy required to push-thru the six-armed shaped particle with tapered arms. All of the
5 shaped particle designs were observed to resist push-thru until the plunger was nearly all of the way through the test block. The tablet geometries fell through after the plunger traveled only a short distance through the block.

Example 2 - Shaped Particle Characteristics

10

In a preferred embodiment a material for the ceramic component of a bone grafting system of the present invention is calcium sulfate. Other materials that could be used include: a calcium salt; hydroxylapatite, a calcium phosphate; bioactive glass, a vitreous based glass (such as may
15 be used for maxio-cranio applications); calcium carbonate, a calcium based mineral; various calcium phosphates, and calcium-rich minerals, including tricalcium phosphate and orthophosphate; apatite/ wollastonite glass ceramic, a calcium silicate often used in bone spacer applications; resorbable polymers such as polysaccharides, polyglycolates, polylactic
20 acid (PLA), polyglycolic acid (PGA), polycaprolactone, polypropylene fumarate (all of which can be blended or made to co-polymers to control the desired properties of the product); and composites of resorbable polymers and glass or ceramic fillers. Bioactive glass is a material whose major components are CaO, SiO₂ and P₂O₅ and whose minor components
25 may be Na₂O, MgO, Al₂O₃, B₂O₃ and CaF₂.

In a specific embodiment the shaped particle of the present invention is colored to make it more visible. In another specific embodiment differently shaped particles of the present invention are denoted with
30 different colors for better differentiation of the particles. In another specific embodiment the particles are coated or have contained within them an

agent such as green fluorescent protein or blue fluorescent protein to make them fluorescent and therefore more visible.

5 The circular cross-section of the extremities, or arms, of the shaped particle of the invention is beneficial for strength purposes, because an equivalent response to loading will occur regardless of the application of the load around the circumference. In contrast, an oval shape as is utilized in commercially available products and in US Patent No. 5,676,700 has reduced resistance to loading when the loading is applied in the
10 direction of the axis of the shorter width of the oval compared to the axis of the longer width of the oval.

Example 3 - Suspension Material

15 It is an object of the present invention to utilize a suspension material to suspend the shaped particles of the invention for easier application to a bone deficiency.

A suspension material may be used as an additional component of a
20 system for a bone graft substitute to treat bone deficiency. The suspension material may be a liquid, putty, dough or gel phase component and may be mixed with the shaped particles described above at the time of use or come as a pre-packaged system. The suspension material could serve two potential functions: 1) to act as a binder to improve handling by
25 forming a putty-like material which is shapeable, and/or 2) to act as a biological tool to assist in the healing through the addition of infection control, bone growth, or other healing or biological agents. The suspension material can provide standard suspension of particles within a material or it may provide adhering of particles or connecting of particles in
30 a manner wherein the material is smaller in volume in an array than the volume of the particles themselves.

The suspension material can either be setting or non-setting in response to time, temperature, presence of body fluid or other external stimuli which might supply energy, such as ultraviolet radiation, magnetic radiation, electromotive force (EMF), radiowaves, or ultrasound. In one embodiment the suspension material will degrade once implanted. Ideally, it would be derived from naturally occurring substances such as carbohydrates, starches or glycerin. It should have a sufficient viscosity as to help the granules adhere to each other to improve intraoperative handling. Coating calcium salts of the preferred embodiment of the shaped particles of the invention with this type of substance may also decrease their affinity to stick to soft tissue, making it easier to remove unwanted pieces from the application site. Fibrinogen/thrombin/Factor XIII combinations may also provide a liquid or gel of appropriate viscosity to use as a binder. The liquid may also be a synthetic material such as calcium sulfate (plaster of Paris) that would set in situ. In another embodiment, this binder could act as a carrier for a variety of agents including but not limited to growth factors, bone morphogenic proteins, fibrinogen/thrombin, antibiotics or some other therapeutic agent (see Example 6).

In a specific embodiment the suspension material is blood, bone marrow, autograft material, or allograft material. These materials are preferentially derived from the patient with the bone deficiency being treated. Alternatively, they are derived from a donor and preferable are free from being the source of disease transmission.

In the invention, a suspension material is used which is compatible with all synthetics (calcium phosphates, calcium sulfates, bioactive glasses, and resorbable polymers). An example of a suspension material is a mixing gel which can be mixed with the synthetic or natural products (autograft or allograft) of choice by the clinician to produce a 'paste' for application to a bone deficiency such as bone void filling. The suspension

material must have the appropriate viscosity and tackiness to agglomerate the particles for easy application to the graft site. Once agglomerated, the paste could be manipulated by hand or be transported by use of a tool such as a scoop, spoon or syringe to the defect site.

5

The suspension material can also reduce the preferential sticking to soft tissue. This adhesion to soft tissue may be caused by a number of factors. Calcium phosphates are known for their affinity for many proteins, as demonstrated by their use in chromatography columns for protein
10 isolation. Thus, their surface chemistry contributes to their preferential sticking to soft tissues of the surgical site which is often covered in blood and protein-containing body fluids. Secondly, many of these commercially available products have rough surfaces that may mechanically adhere to soft tissues such as coral-derived products which contain many
15 interconnected tubules that when fractured create a very rough surface. A suspension material can minimize both effects. In the first case, the suspension material alters the surface chemistry, thus reducing the particles' affinity for proteins. In the second, the suspension material fills in rough features, thereby reducing the particles' ability to mechanically
20 adhere to the tissue.

The suspension material of the present invention may be comprised of biocompatible polymers, and in a specific embodiment the polymers are bioresorbable. The polymers must be graftable into an animal without
25 causing unacceptable side effects. The polymers may be homopolymers or copolymers and are preferably amorphous. A specific example is polymers in which the units are derived from hydroxy carboxylic acids, which are polyesters. Another example is poly(lactic acids) which may originate from the polymerization of mixtures of L- and D-lactides in
30 proportions such that the poly(lactic acids) are amorphous. Another example is copolymers consisting of units derived from lactic and glycolic acids.

A biocompatible polymer may or may not be degradable, depending on the proposed use. Degradable polymers which are nontoxic and implantable into organisms such as humans are preferable, and examples
5 include polyglycolic acid or polylactic acid. Other materials which may be useful based on their biocompatibility and the ability to alter their viscosity and tackiness to prove useful in this invention include: polyvinylpyrrolidone, chitosin, glycerol, carboxymethylcellulose, methylcellulose, carrageenan, hyaluronic acid, collagen-hydroxyapatite-hyaluronic acid composite,
10 alginate, dextrose, starches, cellulose gums or combinations of any of the above listed items. A skilled artisan is aware that collagen or a derivative of collagen is preferably treated prior to use in the invention so as not to be immunoreactive, or alternatively a recombinant form of collagen may be used.

15 A binder is a material that aids in the agglomeration of the particles due to the tackiness of the binder both in a cohesive (with itself) and adhesive (with the particles) nature. The final construct (binder plus particles) still has flexibility and pliability so that it can fill a defect completely. It is possible that plaster of Paris or a settable calcium
20 phosphate cement system may be used as a binder which will still ultimately set to a firm construct. This would provide an improvement in the immediate structural strength under a loading pattern that is predominately compression. So, therefore, a binder may or may not harden. In a preferred embodiment the binder hardens.

25 Examples of appropriate physiological materials which may be included in the suspension material are saline, various starches, hydrogels, polyvinylpyrrolidines, other polymeric materials, polysaccharides, organic oils or fluids, all of which are well known and
30 utilized in the art. Materials that are biologically compatible, i.e., cause minimal tissue reaction and are removed or metabolized without cytotoxicity, are preferred. Biologically compatible saccharides such as

glucose or aqueous solutions of starch may be used. Certain fats may also be used. In this connection, highly compatible materials include esters of hyaluronic acids such as ethyl hyaluronate and polyvinylpyrrolidone (PVP). PVP normally has the general empirical
5 formula $[\text{CHCH}_2)_2\text{N}(\text{CH}_2)_3\text{CO}]_n$ wherein n equal 25-500, a form otherwise known as Plasdone ® (trademark of GAF Corporation, New York, NY). Another biocompatible material is a patient's own plasma. Blood may be withdrawn from the patient, centrifuged to remove cells (or not) and mixed with appropriate volume of particles and the mixture applied in the desired
10 locations.

In a preferred embodiment the suspension material is comprised of the following: carboxymethylcellulose (maximum of 3 weight percent); glycerol USP (maximum of 20 weight percent); and purified water USP (maximum of 88.75 weight percent). The advantages to utilizing the
15 suspension material of the invention which are improvements over currently available products derived from human tissue include: improved handling; lower cost; no risk of disease; easier storage; longer shelf life; ease of discarding any excess material; compatibility with all known synthetics; and unlimited supply.

20

Example 4 - Polymeric Shaped Particle

In another object of the present invention the shaped particles of the invention are of a polymeric phase. The material could be derived from a
25 wide variety of bioabsorbable, biocompatible polymers that will resorb or degrade over time. These polymers could also be ceramic or glass filled in order to boost the osteoconductivity of the polymer alone. The polymers, or composites, also allow control of mechanical properties, such as strength and stiffness, and control of degradation rates. The function of
30 this component is to offer compliance to a bone graft system comprised of this material and the ceramic and suspension material phases described above. In a preferred embodiment the polymeric shaped particles will

interlock with a ceramic-based particle, still maintaining a certain volume of the combination that is open and has an interconnected porosity. The polymeric granule also protects the ceramic components from brittle fracture under compaction, acting as a buffer while the system is

5 compressed to fill a bone deficiency. In order to achieve these properties it is envisioned that the polymeric shaped particles will be mostly plastic in their behavior with a small portion of elastic response. This will insure that the polymeric shaped particles will compress without too much rebound, but that they will also serve as buffers between the ceramic granules. It is

10 also conceivable that the polymeric/composite granules may be used without the ceramic granules in some indications where the ability to compact the material is very important, such as in the compaction grafting technique commonly used today in total joint revisions. No current ceramic shaped particle system is suitable for compaction since they

15 would be pulverized by this technique.

In a preferred embodiment the shaped particle of polymer has as the ends of its extremities a bubble shape which may provide a "snap-fit" for adjacent interlocking polymeric shaped particles, such as the particles

20 illustrated in Figures 4 and 5.

Example 5 - A Bone Graft System

Together, the three components of the invention which provide a

25 bone graft substitute system, including a ceramic shaped particle, a suspension material, and a polymeric shaped particle, will offer the clinician several options when approaching a grafting procedure. The most basic option would be to use the ceramic granules alone when the defect is contained and does not have to provide a lot of mechanical or

30 structural support. When the suspension material is added the clinician will be able to work with the granules outside of the bone deficiency site to shape the aggregate. The suspension material may also offer the

possibility to introduce infection control or active agents to promote bone healing and growth. The addition of the polymeric shaped particles to the ceramic shaped particles offers the clinician the ability to compress the graft into a deficient site. This would be beneficial when more structural support and stability was required of the implant and might also be more suited to larger volume defects. The system may also include allograft material, such as chips, blocks, putties and gels) or in addition or alternatively may include autograft material.

10 In a specific embodiment the system will include multiple shaped particles wherein the particles are of different shapes. The different shapes which may be included are illustrated in the figures herein or may have variations of these shapes. In addition or alternatively these multiple particles may be comprised of different materials.

15 As seen from the currently available products, the typical approach to address the breadth of properties required from bone graft materials is to provide multiple bone graft materials with the intention to apply each to a specific class of indications. If the clinician requires a mixture of properties or attributes, the clinician must mix the currently available products from different manufacturers to obtain a desirable set of attributes or move on to another product already designed with the right set of attributes. Thus, in the present invention, a system of products that may be used either independently or mixed with any of the other constituents in the system is provided. A list of the constituents envisioned include: a bioceramic component with osteoconductive properties that is available as a shaped particle; suspension material that aids primarily in the delivery of the shaped particles; a compliant shaped particle with improved mechanical properties that mimics the compliance of allograft cancellous bone; a fibrin matrix (see Example 7) that can act as a carrier as with the suspension material but can provide some enhancement to bone healing, as well as act as a carrier for the following items; antibiotics, cancer therapy,

osteoporosis therapies, or therapies for other bone mineralization disorders that can affect the overall efficacy of a bone graft material depending on the complications associated with the graft procedure; growth factors, bone morphogenic proteins, or protein fragments that can further enhance bone healing and/or have a specific high affinity for the fibrin matrix (these factors may utilize wide variety of pathways to meet the end results such as influencing the development of mesenchymal stem cells, growth and reproduction of osteoblast/osteoclast/osteocytes, chemotoxic agents that encourage mitogenesis and re-population by the osteoblasts/osteoclasts/osteocytes, angiogenic agents, etc.); cells which may also be delivered using a fibrin matrix which are beneficial to bone healing such as osteoblasts, osteoclasts, and/or osteocytes; allograft bone and bone products; and other biological agents.

In a preferred embodiment these components are compatible with autograft. It is generally known that clinicians prefer to use autograft over existing synthetics since it is the tissue which is trying to be emulated. Clinicians will mix in autograft and/or blood to fill in the missing aspects or properties (primarily to capture the bioactive aspects) of the currently available products in an object of the present invention.

The present bone graft system invention offers several improvements over current bone graft substitutes: all components may be resorbable/degradable in-vivo (current products offered include both resorbable/degradable and permanent structure); interlocking structure increases mechanical strength and stability of the granular structure (particularly under shear forces) relative to the current designs of random and regular, non-interlocking structures; interlocking structure that also maintains open, interconnected porosity which allows the individual shaped particles (especially ceramic) to be dense and therefore less likely to chip and break than current porous (ceramic) structures which are friable and weak; dense shaped particles will not adhere to soft tissues as

will the currently available porous ceramic structures; offering product as a shaped particle allows the clinician to fill a large range of defect sizes, whereas current products offer granule and block forms; a multi-component system allows the clinician to tailor the bone graft to the needs
5 of the patient without having to utilize many different product offerings (current products do not offer this flexible, systematic approach); the addition of antibiotics to the system allows the clinician to graft at an earlier stage in cases where infection is a concern; and the addition of biological factors which may hasten the bone healing process to or onto a
10 component of the system of the invention can provide superior mechanical support which will offer an advantage over the current delivery system (a collagen sponge) for such molecules.

The integral advantage of a system of the invention is that it
15 eliminates the need to develop a specific product for each specific indication. The clinician can now mix/match the components of the system as needed to provide the desirable mixture of attributes, thus having the ability to tailor or design a bone graft product for each patient to suit his or her unique needs and specific complications. This results in a lower cost
20 to the patient who will be charged only for the products used.

Flexibility in pharmaceutical choice to match infectious agents is also an advantage of the present invention. In the case of antibiotics, the clinician can choose the appropriate antibiotic based on the culture results
25 from the wound. In the case of some currently available products, the clinician has only one choice for an antibiotic (tobramycin).

There is also provided greater ease of storage and lower distribution costs as compared to products which directly incorporate bioactive
30 proteins, cells, or pharmaceuticals. These 'active' ingredients have specific storage conditions and limited shelf lives. If the products are pre-mixed, the manufacturer runs the risk of having to dispose of the entire

product at expiration rather than the 'active' ingredient with the shorter shelf life. This also eliminates issues caused by the potential for interactions between the 'active' ingredients and the device during long storage times.

5

Furthermore, if the bone graft already contains the pharmaceutical or bioactive protein or cells, then the product may be limited in its use to treat larger defects for fear of over dosing. Similar issues are encountered in treating small defects where the dose may be too small to have a
10 beneficial outcome. Giving the clinician the ability to set the dose allows that the proper dose will be used in all cases.

Example 6 - Addition of Biological Agents to the System

15 In a preferred embodiment of the present invention a biological agent is included in the suspension material. Examples include antibiotics, growth factors, fibrin (see Example 7), bone morphogenetic factors, bone growth agents, chemotherapeutics, pain killers, bisphosphonates, strontium salt, fluoride salt, magnesium salt, and sodium salt.

20

In contrast to administering high doses of antibiotic orally to an organism, the present invention allows antibiotics to be included within the suspension material of the composition for a local administration. This reduces the amount of antibiotic required for treatment of or prophylaxis
25 for an infection. Administration of the antibiotic by the suspension material in a composition would also allow less diffusing of the antibiotic, particularly if the antibiotic is contained within a fibrin matrix (see Example 7). Alternatively, the particles of the present invention may be coated with the antibiotic and/or contained within the particle or the suspension
30 material. Examples of antibiotics are tetracycline hydrochloride, vancomycin, cephalosporins, and aminoglycosides such as tobramycin and gentamicin.

Growth factors may be included in the suspension material for a local application to encourage bone growth. Examples of growth factors which may be included are platelet derived growth factor (PDGF), transforming growth factor β (TGF- β), insulin-related growth factor-I (IGF-I), insulin-related growth factor-II (IGF-II), fibroblast growth factor (FGF), beta-2-microglobulin (BDGF II) and bone morphogenetic protein (BMP). The particles of the present invention may be coated with a growth factor and/or contained within the particle or the suspension material.

10

Bone morphogenetic factors may include growth factors whose activity is specific to osseous tissue including proteins of demineralized bone, or DBM (demineralized bone matrix), and in particular the proteins called BP (bone protein) or BMP (bone morphogenetic protein), which actually contains a plurality of constituents such as osteonectin, osteocalcin and osteogenin. The factors may coat the shaped particles of the present invention and/or may be contained within the particles or the suspension material.

Bone growth agents may be included within the suspension material of the composition of the invention in a specific embodiment. For instance, nucleic acid sequences which encode an amino acid sequence, or an amino acid sequence itself may be included in the suspension material of the present invention wherein the amino acid sequence facilitates bone growth or bone healing. As an example, leptin is known to inhibit bone formation (Ducy et al., 2000). Any nucleic acid or amino acid sequence which negatively impacts leptin, a leptin ortholog, or a leptin receptor may be included in the composition. As a specific example, antisense leptin nucleic acid may be transferred within the composition of the invention to the site of a bone deficiency to inhibit leptin amino acid formation, thereby avoiding any inhibitory effects leptin may have on bone regeneration or

30

growth. Another example is a leptin antagonist or leptin receptor antagonist.

5 The nucleic acid sequence may be delivered within a nucleic acid vector wherein the vector is contained within a delivery vehicle. An example of such a delivery vehicle is a liposome, a lipid or a cell. In a specific embodiment the nucleic acid is transferred by carrier-assisted lipofection (Subramanian et al., 1999) to facilitate delivery. In this method, a cationic peptide is attached to an M9 amino acid sequence and the
10 cation binds the negatively charged nucleic acid. Then, M9 binds to a nuclear transport protein, such as transportin, and the entire DNA/protein complex can cross a membrane of a cell.

An amino acid sequence may be delivered within a delivery vehicle.
15 An example of such a delivery vehicle is a liposome. Delivery of an amino acid sequence may utilize a protein transduction domain, an example being the HIV virus TAT protein (Schwarze et al., 1999).

In a preferred embodiment the biological agent of the present
20 invention has high affinity for a fibrin matrix (see Example 7).

In a specific embodiment, the particle of the present invention may contain within it or on it a biological agent which would either elute from the particle as it degrades or through diffusion.
25

The biological agent may be a pain killer. Examples of such a pain killer are lidocaine hydrochloride, bupivacaine hydrochloride, and non-steroidal anti-inflammatory drugs such as ketorolac tromethamine.

30 Other biological agents which may be included in the suspension material or contained on or in the particles of the present invention are chemotherapeutics such as cis-platinum, ifosfamide, methotrexate and

doxorubicin hydrochloride. A skilled artisan is aware which chemotherapeutics would be suitable for a bone malignancy.

Another biological agent which may be included in the suspension
5 material or contained on or in the particles of the present invention is a
bisphosphonate. Examples of bisphosphonates are alendronate,
clodronate, etidronate, ibandronate,
(3-amino-1-hydroxypropylidene)-1,1-bisphosphonate (APD),
dichloromethylene bisphosphonate, aminobisphosphonatezolendronate
10 and pamidronate.

The biological agent may be either in purified form, partially purified
form, commercially available or in a preferred embodiment are
recombinant in form. It is preferred to have the agent free of impurities or
15 contaminants.

Example 7 - Addition of Fibrinogen to the Composition

It is advantageous to include into the composition of shaped particles
20 and suspension material any factor or agent which attracts, enhances, or
augments bone growth. In a specific embodiment the composition further
includes fibrinogen which, upon cleaving by thrombin, gives fibrin. In a
more preferred embodiment Factor XIII is also included to crosslink fibrin,
giving it more structural integrity.

25

Fibrin is known in the art to cause angiogenesis (growth of blood
vessels) and in an embodiment of the present invention acts as an
instigator of bone growth. It is preferred to mimic signals which are
normally present upon, for instance, breaking of bone to encourage
30 regrowth. It is known that fibrin tends to bind growth factors which
facilitate this regrowth.

In an object of the present invention the inclusion of fibrin into the composition is twofold: 1) to encourage bone growth; and 2) to act as a delivery vehicle.

5 The fibrin matrix is produced by reacting three clotting factors - fibrinogen, thrombin, and Factor XIII. These proteins may be manufactured using recombinant techniques to avoid issues associated with pooled-blood products and autologous products. Currently, the proteins are supplied in a frozen state ready for mixing upon thawing.
10 However, lyophilization process development allows that the final product will either be refrigerated or stored at room temperature and reconstituted immediately prior to use. In a preferred embodiment the clotting factors are recombinant in form.

15 Only fibrinogen and thrombin are required to produce a fibrin matrix in its simplest form. However, the addition of Factor XIII provides the ability to strengthen the matrix by means of cross linking the fibrin fibrils. Specific mixtures of the three proteins may be provided to generate the appropriate reaction time, degradation rate, and elution rate for the
20 biological agents.

 Modifications can be made by altering the fibrin component. One expected modification would be to use hyaluronic acid or a collagen gel instead of or in addition to a fibrin component. Other variations may be
25 inclusion of additional clotting factors in the fibrin matrix. Additional examples of clotting factors are known in the art and may be used, but in a specific embodiment they are clotting factors relevant to a bone disorder. The clotting factors may be purified, partially purified, commercially available, or in recombinant form. In a specific embodiment thrombin
30 alone is used with the patient's own blood or bone marrow aspirate to produce a fibrin matrix.

In a specific embodiment a biological agent as described above is contained within the fibrin matrix.

Example 8 - Method of Making a Calcium Sulfate-based Shaped

5 Particle

In another object of the present invention, an improved method for making a calcium sulfate-based shaped particle, is provided. Calcium sulfate materials are typically not very strong when formed using
10 conventional forming techniques. Plaster of Paris ($\text{CaSO}_4 \cdot \frac{1}{2}\text{H}_2\text{O}$; calcium sulfate hemihydrate) can be mixed with water and set through the following reaction to form gypsum ($\text{CaSO}_4 \cdot 2\text{H}_2\text{O}$; calcium sulfate dihydrate):

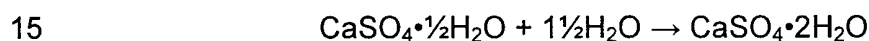

However, in order to have a pourable slurry, an excess of water is required which increases porosity leading to a weaker material. In addition, the high surface area to volume ratio of the porous component
20 can lead to increased dissolution rates of the material in an aqueous environment.

Another option is to utilize a gypsum material and form it into a shape through compaction of slurry casing. Since the gypsum is already fully
25 hydrated the material will not set through a reaction as above. If water is used in the processing it is simply dried off, again leading to porosity in the final form.

This process invention allows the material to be formed using
30 techniques that can provide the desired component geometry and reasonable density in the dried component. A secondary process of heat treatment and hydration is then used to tailor the final material properties,

namely for the purpose of increasing the strength and decreasing the dissolution rate. It should be possible to control these properties with the control of the forming process and the subsequent dehydration/rehydration. In specific embodiments the heating steps are performed at a pressure greater than ambient pressure, such as in an autoclave at 120-150 degrees Celsius or 25-50 PSI. A skilled artisan is aware that the calcium sulfate composition of the invention may be of the α or β form depending on the heat and pressure parameters utilized, and either form may be used or generated in the present invention.

10

In the process a heat treatment and hydration process is applied to gypsum after it is formed into a shape (through pressing, casting, injection or other means known in the art). Similarly, the process could be done on a shaped component of plaster of Paris that was formed by some non-water based process (i.e.: die compaction). The intention of this secondary processing is to control the strength and dissolution of the gypsum for use in a bone grafting application. By proper control of the secondary processing it is possible to tailor the material properties of the component.

20

Steps in process:

- 1) convert shaped gypsum to shaped plaster of Paris using heat (approximately 150°C)



- 2) convert shaped plaster of Paris back to gypsum, encouraging recrystallization, to improve strength and dissolution properties

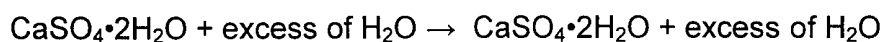

- 3) dry components of excess water

30

Alternative embodiments for products with which this secondary processing could be useful are any application where a stronger gypsum

with more resistance to dissolution by water could be used such as controlled release applications, consumer products, and mold making).

It is an object of the present invention to combine the known
5 substeps of conversion of gypsum powders to plaster of Paris powders (calcination) and rehydration of the plaster of Paris powder to get the material back to gypsum to generate a stronger gypsum.

In this invention, any calcium sulfate may be used which is capable
10 of hydration reaction. This includes gypsum formed in the exhaust gas desulfurization process, gypsum formed as a by-product by neutralization of waste sulfuric acid, gypsum formed as a by-product in the phosphoric acid reproduction process, and calcined gypsum (especially gypsum hemihydrate formed by refining such gypsum product by a known
15 recrystallization method and calcining the refined gypsum). In a preferred embodiment the gypsum is commercially available.

A skilled artisan is aware that the application of water to the particle
in the rehydration step helps to control material properties, including
20 strength, dissolution rates and density.

Example 9 - Forming a Shaped Particle

The process involves the following general steps:

- 25 1. A clay-gypsum powder is mixed with processing aids (such as binders and lubricants) and water to wet and make the clay plastic.
2. A forming operation such as pressing, rolling, extrusion or injection shapes the clay to the desired form.
3. The clay is set in the mold or is in contact with the mold to make a
30 shape with enough green strength to be handled. Setting immediately following the forming should also be good for maintaining the particle geometry and tolerance.

4. The pieces can then be transported to the next processing step or to packaging.

The following is a preferred specific embodiment of the process:

- 5 1. Make clay—Gypsum powder about 75 to 85 w/c (weight percent); carboxymethyl cellulose or other binder material about 0 to 5 w/c; water about 10 to 25 w/c.
2. Press clay—using a split mold, press the gypsum clay under an applied load (approximately 3000 lbs-force).
- 10 3. Set clay in mold—Apply heat to the mold with the gypsum clay. Apply the heat such that the temperature of the parts achieves approximately 100°C in about 5 minutes. Setting occurs through dehydration.
4. Remove pieces from mold.

15

It is generally preferred that the ceramic material for the shaped particle of the invention should not be too hard, sticky or dry.

20

There are many materials that may be suitable for use as binders, including carboxymethyl cellulose, hydroxypropylmethyl cellulose, or polyacrylate.

25

The shaping methods of the present invention can include pressing in a split mold, injection molding, rolling and extrusion.

30

The 'setting' action for the clay can be by simple dehydration or could be some more complex reaction that is mitigated by the combination of binders, water and gypsum and controlled by some external stimuli such as heat, radiation or chemical addition.

All patents and publications mentioned in the specification are indicative of the level of those skilled in the art to which the invention

pertains. All patents and publications are herein incorporated by reference to the same extent as if each individual publication was specifically and individually indicated to be incorporated by reference.

5 Ducy, P., Amling, M., Takeda, S., Priemel, M., Schilling, A.F., Beil, F.T., Shen, J., Vinson, C., Rueger, J.M., and Karsenty, G. 2000. Leptin inhibits bone formation through a hypothalamic relay: a central control of bone mass. *Cell* 100:197-207.

10 Schwarze, S.R., Ho, A., Vocero-Akbani, A. and S.F. Dowdy, 1999. In vivo protein transduction: delivery of a biologically active protein into the mouse. *Science* 285: 1569-1572.

 Subramanian, A., Ranganathan, P. and S.L. Diamond, 1999. Nuclear
15 targeting peptide scaffolds for lipofection of nondividing mammalian cells. *Nature Biotechnology* 17: 873-877.

 One skilled in the art readily appreciates that the present invention is well adapted to carry out the objectives and obtain the ends and
20 advantages mentioned as well as those inherent therein. Particles, compositions, treatments, methods, kits, procedures and techniques described herein are presently representative of the preferred embodiments and are intended to be exemplary and are not intended as limitations of the scope. Changes therein and other uses will occur to
25 those skilled in the art which are encompassed within the spirit of the invention or defined by the scope of the pending claims.

CLAIMS

1. A shaped particle for use in treating a bone deficiency wherein said particle is shaped for use in an array of particles interlocked with one another, comprising:
5 a center portion; and
at least four tapered extremities projecting from said center portion wherein said projections provide for interstitial spaces between adjacent extremities, each extremity having a base attached at said center portion, an opposite point, a length, and a circular transverse
10 cross-sectional configuration, wherein said interstitial spaces of one said particle will accept at least one extremity of an adjacent said particle to facilitate interlocking of adjacent particles in said array.
- 15 2. The particle of Claim 1 wherein at least three of said extremities lie in a plane.
3. The particle of Claim 1 wherein said particle has six extremities.
- 20 4. The particle of Claim 1 wherein said particle is comprised of a material selected from the group consisting of ceramic, bioactive glass, polymer, polymer/ceramic composite, and polymer/glass composite.
- 25 5. The particle of Claim 1 wherein said ceramic is comprised of a calcium salt.
6. The particle of Claim 5 wherein said calcium salt is selected from the group consisting of calcium sulfate, calcium carbonate, calcium
30 phosphate and calcium tartarate.

7. The particle of Claim 6 wherein said particle is comprised of calcium sulfate.
- 5 8. The particle of Claim 7 wherein said calcium sulfate is in the form of gypsum.
9. The particle of Claim 6 wherein said particle is comprised of bioactive glass.
- 10 10. The particle of Claim 4 wherein said particle is comprised of a polymer.
11. The particle of Claim 10 wherein said polymer is selected from the group consisting of polypropylene, polylactic acid, polyglycolic acid and polycaprolactone.
15
12. The particle of Claim 4 wherein said particle is comprised of a polymer/ceramic composite.
- 20 13. The particle of Claim 4 wherein said particle is comprised of a polymer/glass composite.
14. The particle of Claim 1 wherein said particle has a diameter of about 3-10 millimeters.
25
15. The particle of Claim 1 wherein said particle has a diameter of about 4-8 millimeters.
16. The particle of Claim 1 wherein said particle has a diameter of about 6 millimeters.
30
17. The array of Claim 1 wherein said array contains multiple particles.

18. The array of Claim 17 wherein said multiple particles are in a mixture of particles comprised of different materials.
- 5 19. The particles of Claim 18 wherein said different materials are selected from the group consisting of ceramic, calcium salt, bioactive glass, polymer, polymer/ceramic composite, and polymer/glass composite.
- 10 20. The particle of Claim 1 wherein said treatment of a bone deficiency is selected from the group consisting of augmentation of bone, repair of bone, replacement of bone, improvement of bone, strengthening of bone and healing of bone.
- 15 21. The bone deficiency of Claim 20 wherein said bone deficiency is selected from the group consisting of a fracture, break, loss of bone, weak bone, brittle bone, hole in bone, void in bone, disease of bone and degeneration of bone.
- 20 22. The disease of Claim 21 wherein said disease is selected from the group consisting of osteoporosis, Paget's disease, fibrous dysplasia, osteodystrophia, periodontal disease, osteopenia, osteopetrosis, primary hyperparathyroidism, hypophosphatasia, fibrous dysplasia, osteogenesis imperfecta, myeloma bone disease and bone
25 malignancy.
23. The array of Claim 1 wherein said interlocking of said adjacent particles in said array provides adequate porosity to allow ingrowth from a host bone.
- 30 24. The array of Claim 23 wherein said porosity is between about 40% and about 80%.

25. The array of Claim 23 wherein said porosity is between about 60% and about 80%.
- 5 26. An array of shaped particles wherein said array comprises a plurality of shaped particles, said shaped particles comprising:
a center portion; and
at least four tapered extremities projecting from said center portion wherein said projections provide for interstitial spaces between
10 adjacent extremities, each extremity having a base attached at said center portion, an opposite point, a length, and a circular transverse cross-sectional configuration, wherein said interstitial spaces of one said particle will accept at least one extremity of an adjacent said particle to facilitate interlocking of adjacent particles in said array of
15 shaped particles, wherein said array of shaped particles provides for treating a bone deficiency.
27. An array of shaped particles wherein said array comprises a plurality of shaped particles comprising one or more shaped particles from the
20 group consisting of:
a first shaped particle comprising a center portion and at least four tapered extremities projecting from said center portion wherein said projections provide for interstitial spaces between adjacent
25 extremities, each extremity having a base attached at said center portion, an opposite point, a length, and a circular transverse cross-sectional configuration, wherein said interstitial spaces of one said particle will accept at least one extremity of an adjacent said particle to facilitate interlocking of adjacent particles in said array of shaped particles;
30 a second shaped particle comprising a center portion, at least two noncurved extremities, and at least three curved extremities projecting from said center portion wherein said projections provide

for interstitial spaces between adjacent extremities, each extremity having a base attached at said center portion, an opposite point, a length, and a transverse cross-sectional configuration, wherein said interstitial spaces of one said particle will accept at least one
5 extremity of an adjacent said particle to facilitate interlocking of adjacent particles in said array; and
a third shaped particle comprising a multi-ring structure having at least four curved projections wherein said projections provide for interstitial spaces between adjacent said projections, and wherein
10 said projections facilitate interlocking of adjacent particles in said array.

28. A shaped particle for use in treating a bone deficiency wherein said particle is shaped for use in an array of particles interlocked with one
15 another, comprising:
a multi-ring structure having at least four curved projections wherein said projections provide for interstitial spaces between adjacent said projections, and wherein said projections facilitate interlocking of adjacent particles in said array.

20
29. The shaped particle of Claim 28 wherein the angles between said curved projections are equal.

30. The shaped particle of Claim 28 wherein said particle is comprised of
25 material selected from the group consisting of a polymer, polymer/ceramic composite and polymer/glass composite.

31. The polymer of Claim 30 wherein said polymer is selected from the group consisting of polypropylene, polylactic acid, polyglycolic acid
30 and polycaprolactone.

32. A composition for use in treating a bone deficiency comprising:

- a suspension material; and
a shaped particle from the group consisting of
a first shaped particle comprising a center portion and at least four
tapered extremities projecting from said center portion wherein said
5 projections provide for interstitial spaces between adjacent
extremities, each extremity having a base attached at said center
portion, an opposite point, a length, and a circular transverse cross-
sectional configuration, wherein said interstitial spaces of one said
particle will accept at least one extremity of an adjacent said particle
10 to facilitate interlocking of adjacent particles in said array of shaped
particles;
a second shaped particle comprising a center portion, at least two
noncurved extremities, and at least three curved extremities
projecting from said center portion wherein said projections provide
15 for interstitial spaces between adjacent extremities, each extremity
having a base attached at said center portion, an opposite point, a
length, and a transverse cross-sectional configuration, wherein said
interstitial spaces of one said particle will accept at least one
extremity of an adjacent said particle to facilitate interlocking of
20 adjacent particles in said array; and
a third shaped particle comprising a multi-ring structure having at
least four curved projections wherein said projections provide for
interstitial spaces between adjacent said projections, and wherein
said projections facilitate interlocking of adjacent particles in said
25 array.
33. The suspension material of Claim 32 wherein said suspension
material is selected from the group consisting of starch, sugar,
glycerin, blood, bone marrow, autograft material, allograft material,
30 fibrin clot and fibrin matrix.

34. The suspension material of Claim 33 wherein said suspension material is a binder capable of forming a gel.
35. The binder of Claim 34 wherein said binder is selected from the group consisting of collagen derivative, cellulose derivative, methylcellulose, hydroxypropylcellulose, hydroxypropylmethyl cellulose, carboxymethylcellulose, fibrin clot, fibrin matrix, and a biological adhesive such as cryoprecipitate.
36. The suspension material of Claim 32 wherein said material further comprises a biological agent.
37. The biological agent of Claim 36 wherein said agent is selected from the group consisting of a growth factor, an antibiotic, a strontium salt, a fluoride salt, a magnesium salt, a sodium salt, a bone morphogenetic factor, a chemotherapeutic agent, a pain killer, a bisphosphonate and a bone growth agent.
38. The growth factor of Claim 37 wherein said growth factor is selected from the group consisting of platelet derived growth factor (PDGF), transforming growth factor β (TGF- β), insulin-related growth factor-I (IGF-I), insulin-related growth factor-II (IGF-II), fibroblast growth factor (FGF), beta-2- microglobulin (BDGF II) and bone morphogenetic protein (BMP).
39. The antibiotic of Claim 37 wherein said antibiotic is selected from the group consisting of tetracycline hydrochloride, vancomycin, cephalosporins, and aminoglycocides such as tobramycin and gentamicin.
40. The bone morphogenetic factor of Claim 37 wherein said factor is selected from the group consisting of proteins of demineralized bone,

demineralized bone matrix (DBM), bone protein (BP), bone morphogenetic protein (BMP), osteonectin, osteocalcin and osteogenin.

- 5 41. The chemotherapeutic agent of Claim 37 wherein said agent is selected from the group consisting of cis-platinum, ifosfamide, methotrexate and doxorubicin hydrochloride.
- 10 42. The pain killer of Claim 37 wherein said pain killer is selected from the group consisting of lidocaine hydrochloride, bupivacaine hydrochloride, and non-steroidal anti-inflammatory drugs such as ketorolac tromethamine.
- 15 43. The composition of Claim 32 which further includes a clotting factor composition.
44. The clotting factor composition of Claim 43 wherein said clotting factor composition comprises fibrinogen, thrombin and Factor XIII.
- 20 45. A method to treat a bone deficiency comprising the step of:
applying a shaped particle to a bone deficiency wherein said shaped particle is selected from the group consisting of
a first shaped particle comprising a center portion and at least four tapered extremities projecting from said center portion wherein said
25 projections provide for interstitial spaces between adjacent extremities, each extremity having a base attached at said center portion, an opposite point, a length, and a circular transverse cross-sectional configuration, wherein said interstitial spaces of one said particle will accept at least one extremity of an adjacent said particle
30 to facilitate interlocking of adjacent particles in said array of shaped particles;

5 a second shaped particle comprising a center portion, at least two noncurved extremities, and at least three curved extremities projecting from said center portion wherein said projections provide for interstitial spaces between adjacent extremities, each extremity having a base attached at said center portion, an opposite point, a length, and a transverse cross-sectional configuration, wherein said interstitial spaces of one said particle will accept at least one extremity of an adjacent said particle to facilitate interlocking of adjacent particles in said array; and

10 a third shaped particle comprising a multi-ring structure having at least four curved projections wherein said projections provide for interstitial spaces between adjacent said projections, and wherein said projections facilitate interlocking of adjacent particles in said array.

15

46. A method to treat a bone deficiency comprising the steps of:
combining a shaped particle with a suspension material wherein said particle is selected from the group consisting of

20 a first shaped particle comprising a center portion and at least four tapered extremities projecting from said center portion wherein said projections provide for interstitial spaces between adjacent extremities, each extremity having a base attached at said center portion, an opposite point, a length, and a circular transverse cross-sectional configuration, wherein said interstitial spaces of one said particle will accept at least one extremity of an adjacent said particle to facilitate interlocking of adjacent particles in said array of shaped particles;

25

30 a second shaped particle comprising a center portion, at least two noncurved extremities, and at least three curved extremities projecting from said center portion wherein said projections provide for interstitial spaces between adjacent extremities, each extremity having a base attached at said center portion, an opposite point, a

length, and a transverse cross-sectional configuration, wherein said interstitial spaces of one said particle will accept at least one extremity of an adjacent said particle to facilitate interlocking of adjacent particles in said array; and

5 a third shaped particle comprising a multi-ring structure having at least four curved projections wherein said projections provide for interstitial spaces between adjacent said projections, and wherein said projections facilitate interlocking of adjacent particles in said array; and

10 applying said combination to a bone deficiency.

47. A kit for the treatment of a bone deficiency comprising:

a suspension material; and

multiple first shaped particles and multiple second shaped particles

15 wherein said first and second particles are shaped for use in an array of particles interlocked with one another and wherein said particles are selected from the group consisting of

a first shaped particle comprising a center portion and at least four tapered extremities projecting from said center portion wherein said

20 projections provide for interstitial spaces between adjacent extremities, each extremity having a base attached at said center portion, an opposite point, a length, and a circular transverse cross-sectional configuration, wherein said interstitial spaces of one said particle will accept at least one extremity of an adjacent said particle

25 to facilitate interlocking of adjacent particles in said array of shaped particles;

a second shaped particle comprising a center portion, at least two noncurved extremities, and at least three curved extremities

projecting from said center portion wherein said projections provide

30 for interstitial spaces between adjacent extremities, each extremity having a base attached at said center portion, an opposite point, a length, and a transverse cross-sectional configuration, wherein said

interstitial spaces of one said particle will accept at least one extremity of an adjacent said particle to facilitate interlocking of adjacent particles in said array; and
a third shaped particle comprising a multi-ring structure having at least four curved projections wherein said projections provide for interstitial spaces between adjacent said projections, and wherein said projections facilitate interlocking of adjacent particles in said array.

- 5
- 10 48. The kit of Claim 47 wherein said multiple first and said multiple second shaped particles are composed of different materials.
49. The kit of Claim 48 wherein said different materials are selected from the group consisting of ceramic, calcium sulphate, bioactive glass, polymer, polymer/ceramic composite, and polymer/glass composite.
- 15
50. The kit of Claim 47 further comprising a biological agent.
51. The kit of Claim 47 further comprising allograft material.
- 20
52. The kit of Claim 47 further comprising a clotting factor composition.
53. The clotting factor composition of Claim 52 wherein said clotting factor composition comprises fibrinogen, thrombin and Factor XIII.
- 25
54. The kit of Claim 47 further comprising a bowl container for said multiple first and multiple second particles and a delivery tool.
55. The delivery tool of Claim 54 wherein said delivery tool is selected from the group consisting of a spoon, a spatula, a scoop, a tweezer, forceps, a knife, a hemostat, a syringe, a pipette, a cup and a ladle.
- 30

56. The bowl container of Claim 54 wherein said bowl is used for mixing said multiple first and multiple second particles and said suspension material.
- 5 57. The kit of Claim 50 further comprising a bowl container for said multiple first and multiple second particles and a delivery tool.
58. The delivery tool of Claim 57 wherein said delivery tool is selected from the group consisting of a spoon, a spatula, a scoop, a tweezer,
10 forceps, a knife, a hemostat, a syringe, a pipette, a cup and a ladle.
59. The bowl container of Claim 59 wherein said bowl is used for mixing said multiple first and multiple second particles, said suspension material, and said biological agent.
- 15 60. A shaped particle for use in treating a bone deficiency wherein said particle is shaped for use in an array of particles interlocked with one another, comprising:
a center portion;
20 at least two noncurved extremities; and
at least three curved extremities projecting from said center portion wherein said projections provide for interstitial spaces between adjacent extremities, each extremity having a base attached at said center portion, an opposite point, a length, and a transverse cross-
25 sectional configuration, wherein said interstitial spaces of one said particle will accept at least one extremity of an adjacent said particle to facilitate interlocking of adjacent particles in said array.
61. A method for manufacturing a shaped particle of calcium sulphate dihydrate comprising the steps of:
30 making a shaped particle of calcium sulphate dihydrate;
heating said particle; and

applying water to said particle.

62. A method for manufacturing a shaped particle of calcium sulphate dihydrate comprising the steps of:
- 5 making a shaped particle of calcium sulphate dihydrate;
heating in the presence of pressure and moisture said particle of calcium sulphate dihydrate to convert said particle to α -calcium sulphate hemihydrate partially or in full; and
applying water to said particle to convert said α -calcium sulphate hemihydrate to said calcium sulphate dihydrate.
- 10
63. A method for manufacturing a shaped particle of calcium sulphate dihydrate comprising the steps of:
- making a shaped particle of calcium sulphate dihydrate;
- 15 heating in the presence of pressure and moisture said particle of calcium sulphate dihydrate to convert said particle to β -calcium sulphate hemihydrate partially or in full; and
applying water to said particle to convert said β -calcium sulphate hemihydrate to said calcium sulphate dihydrate.
- 20

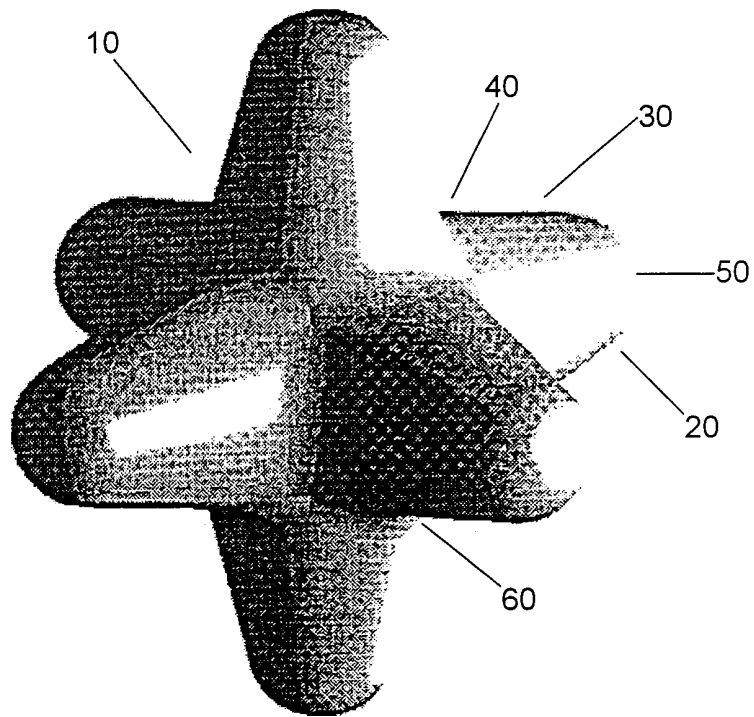

Fig. 1

2/13

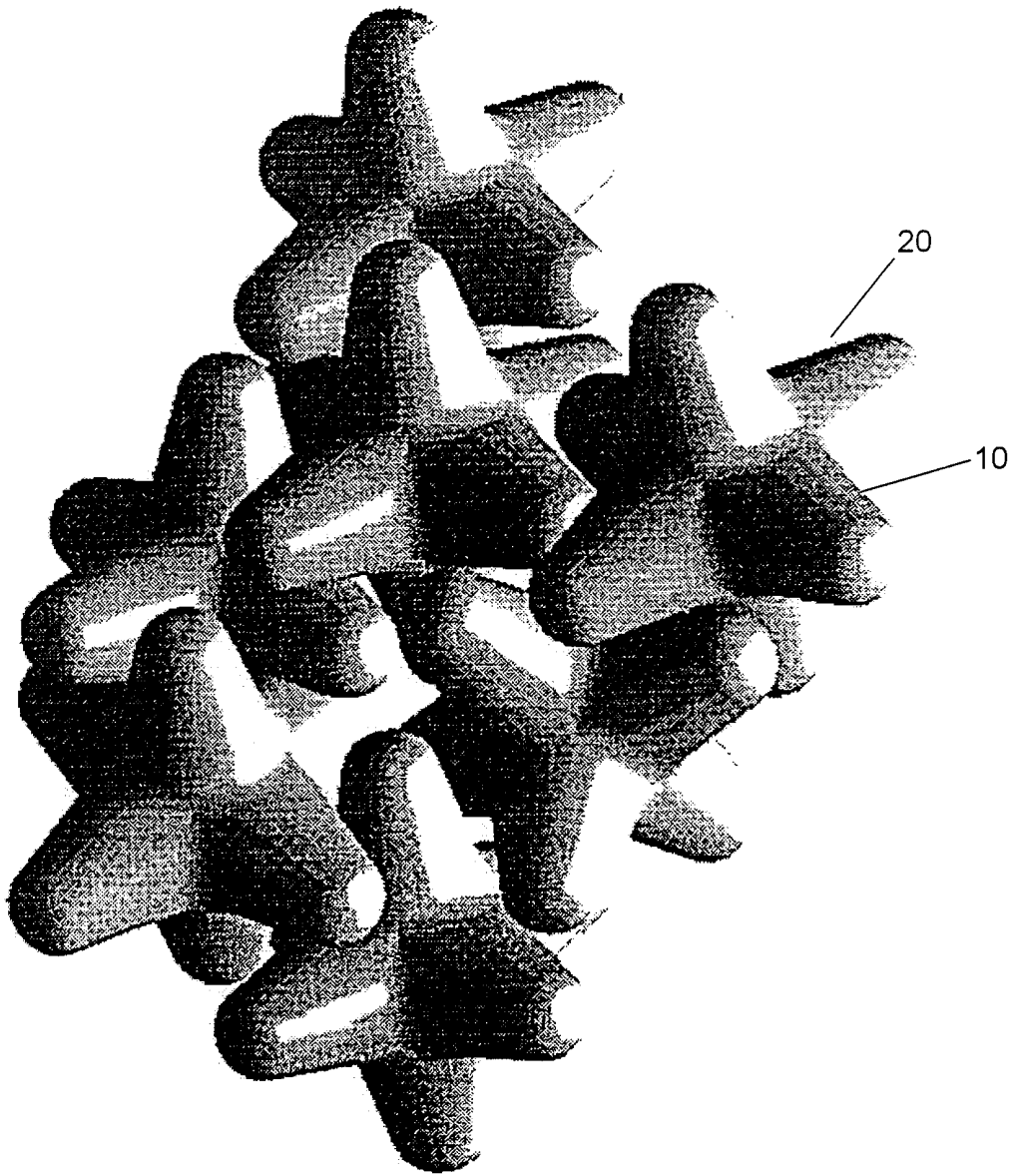

Fig. 2

3/13

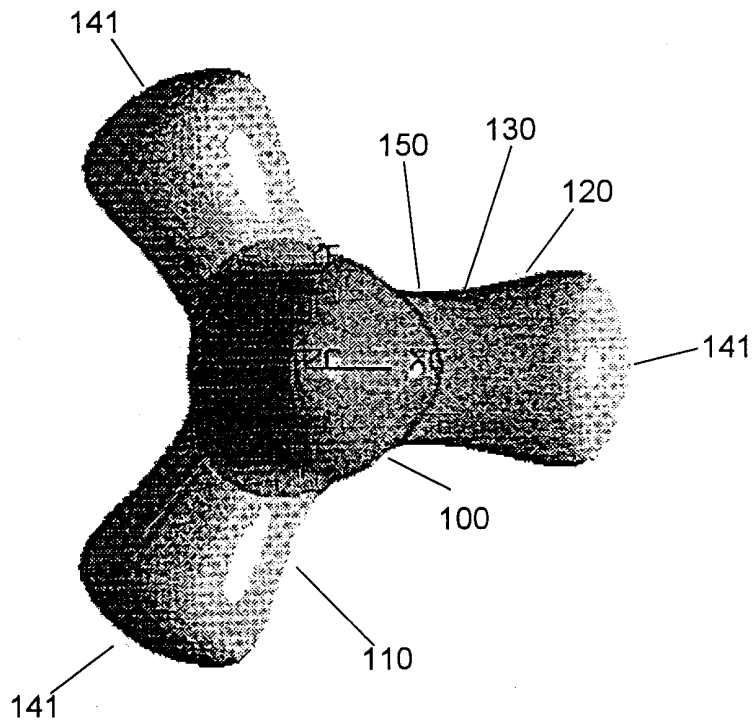

Fig. 3A

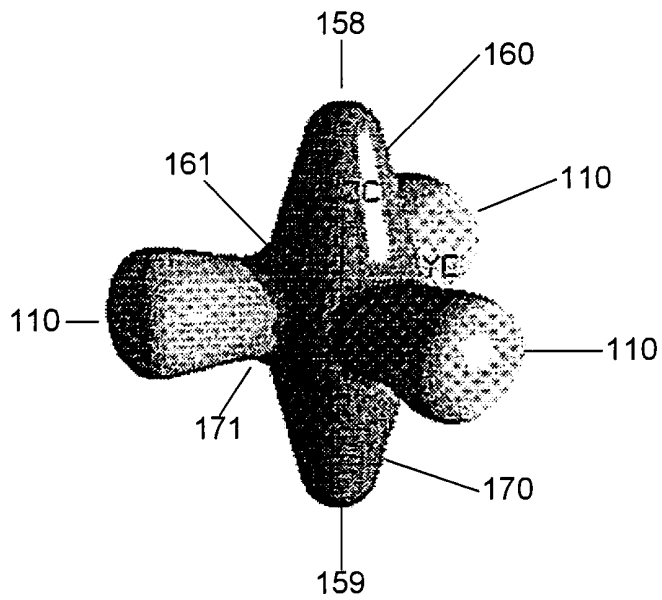

Fig. 3B

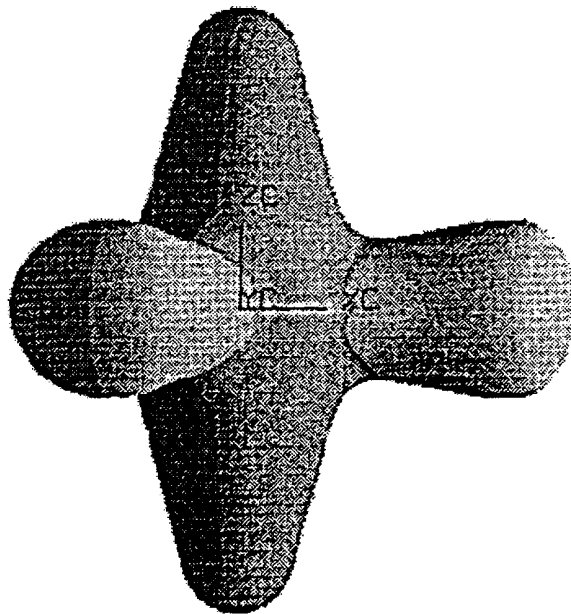

Fig. 3C

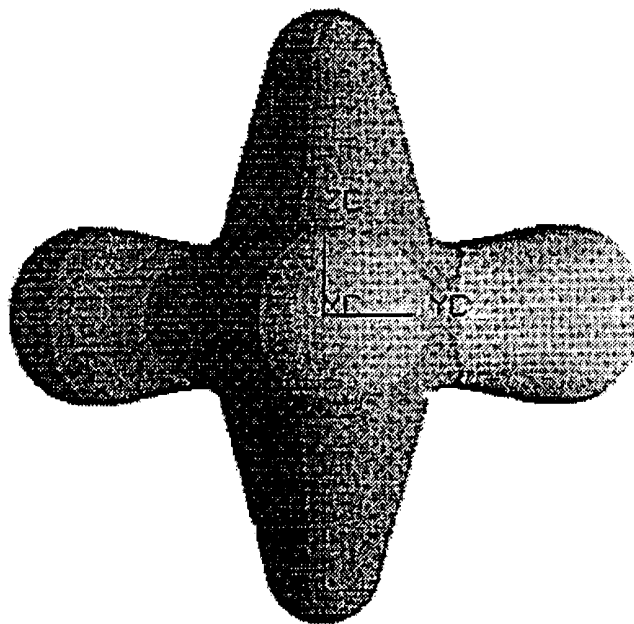

Fig. 3D

5/13

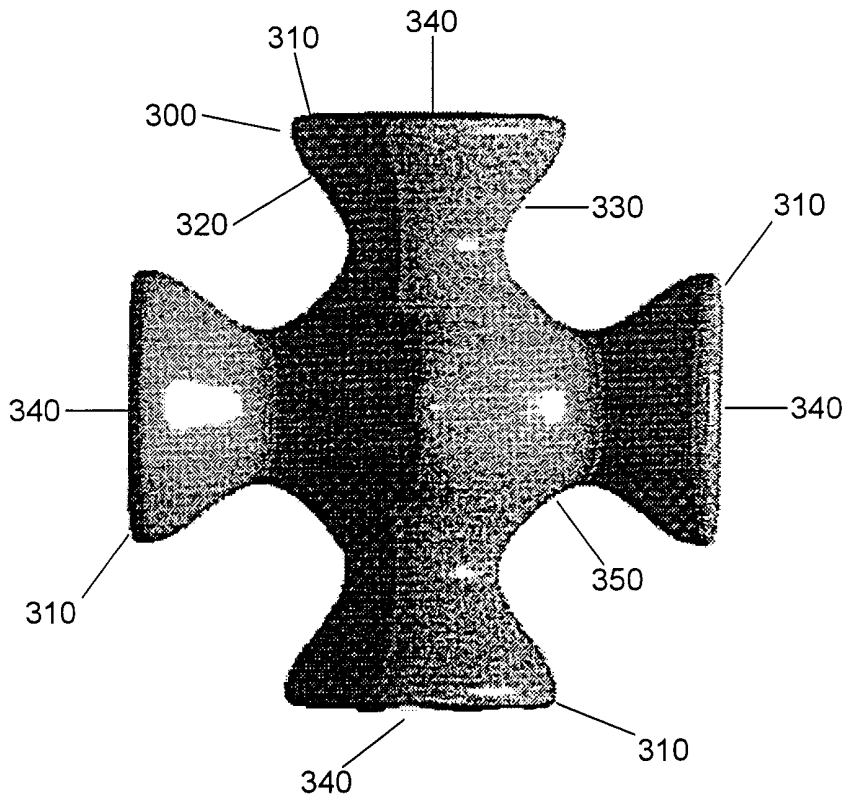

Fig. 4A

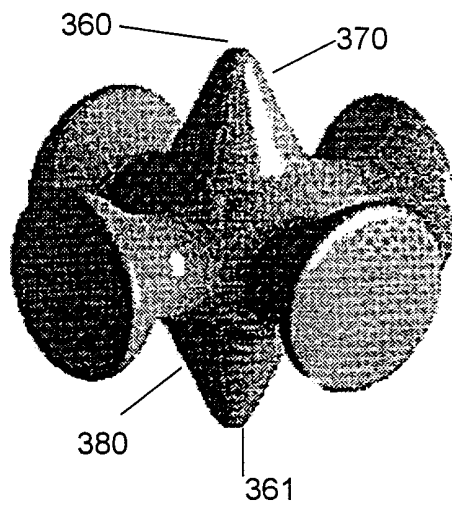

Fig. 4B

6/13

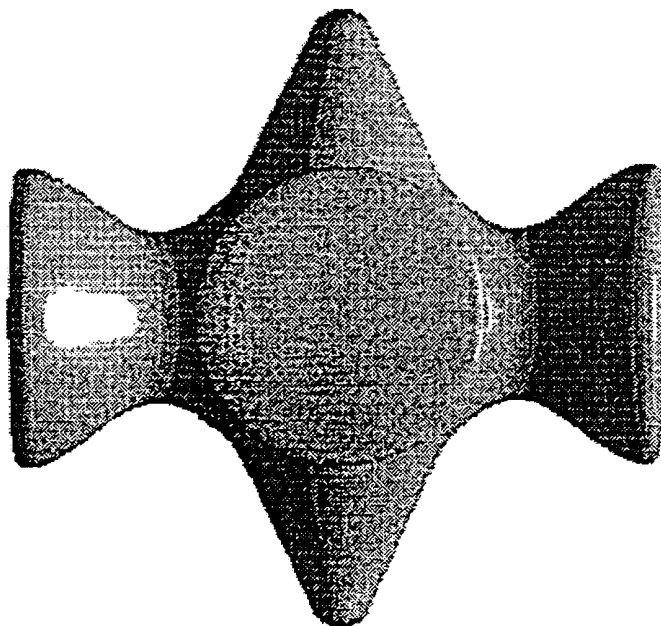

Fig. 4C

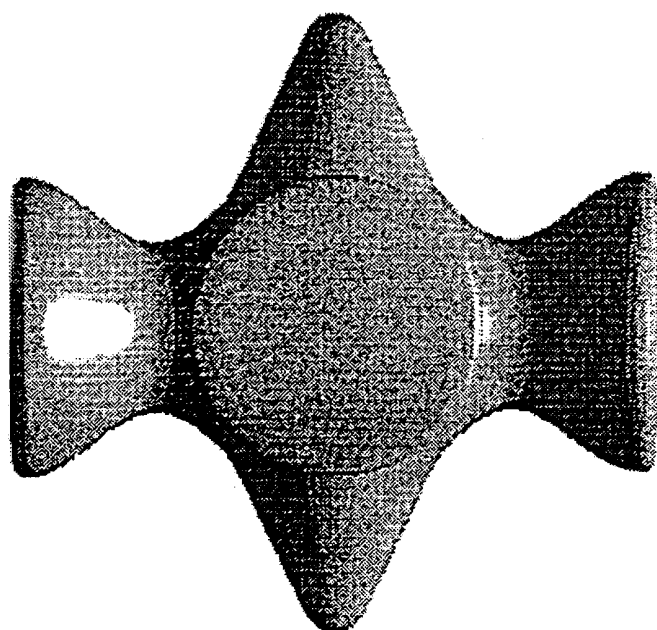

Fig. 4D

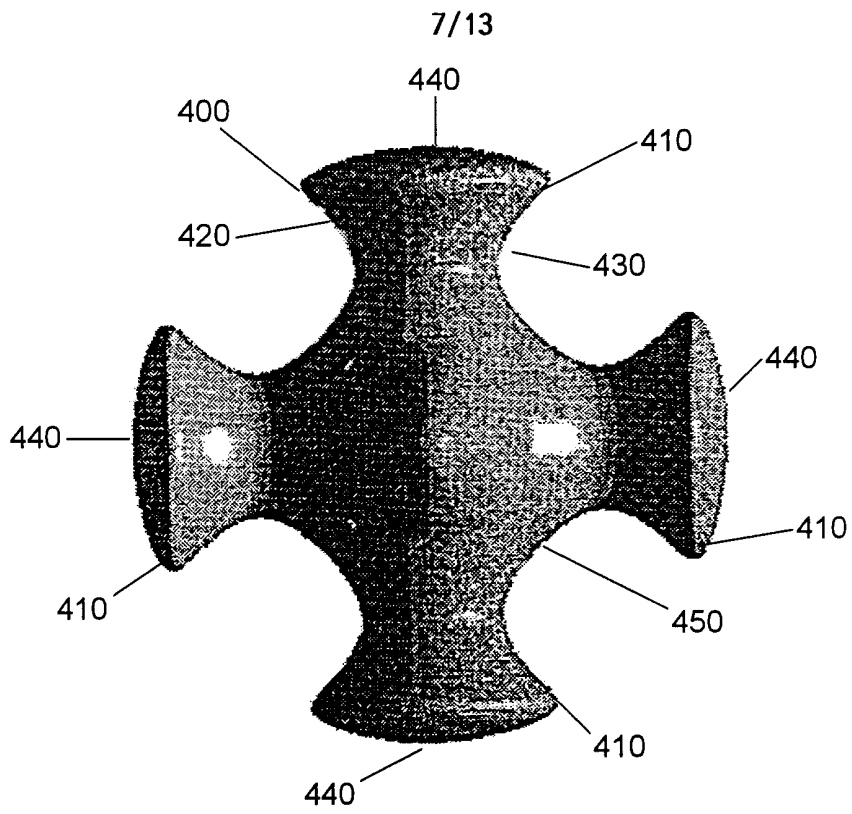

Fig. 5A

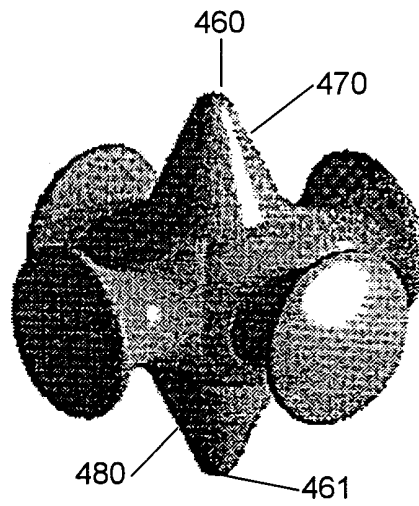

Fig. 5B

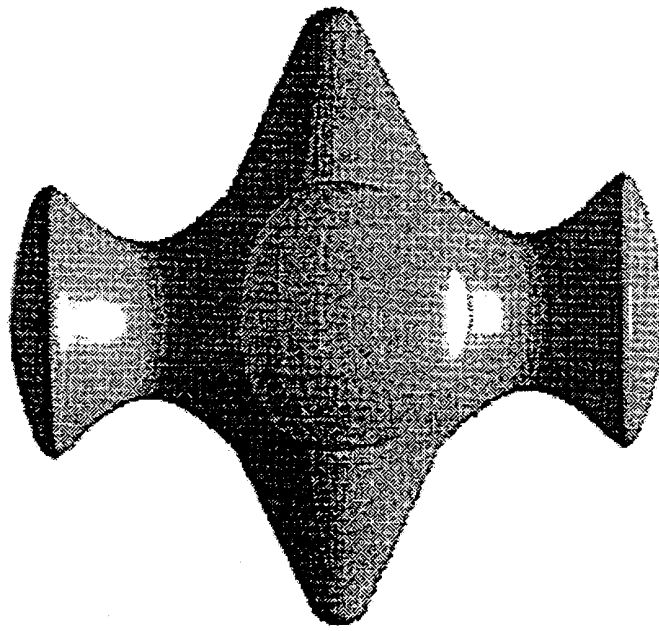

Fig. 5C

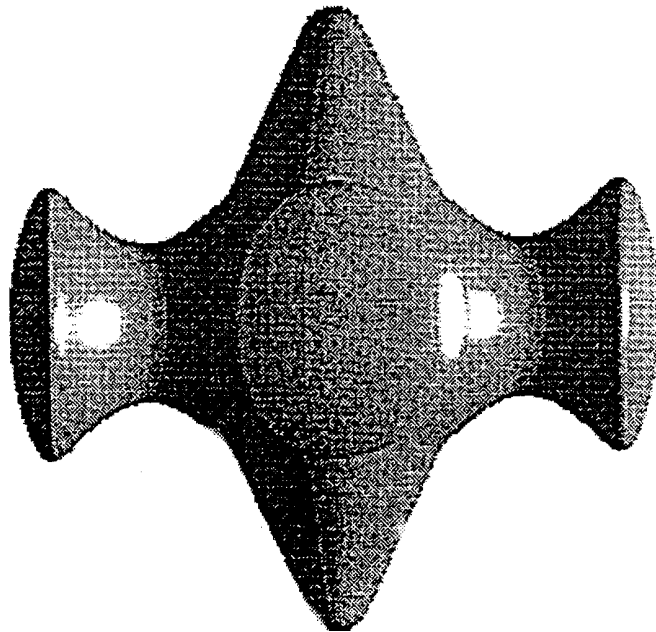

Fig. 5D

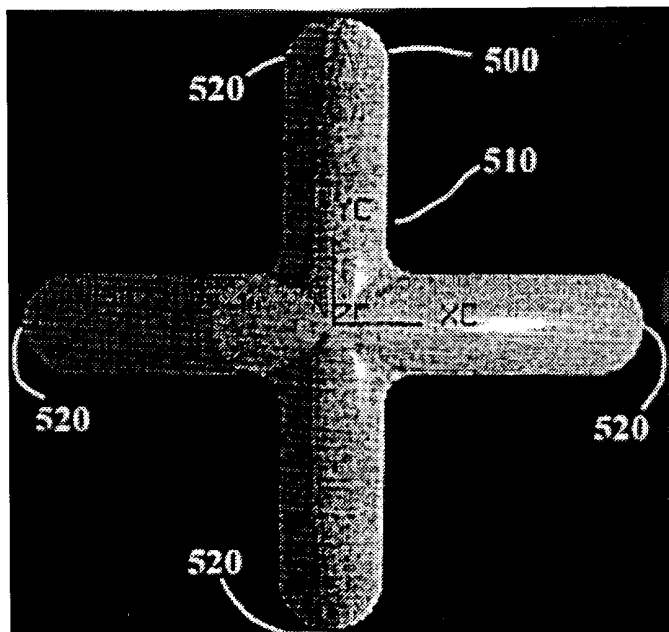

Fig. 6A

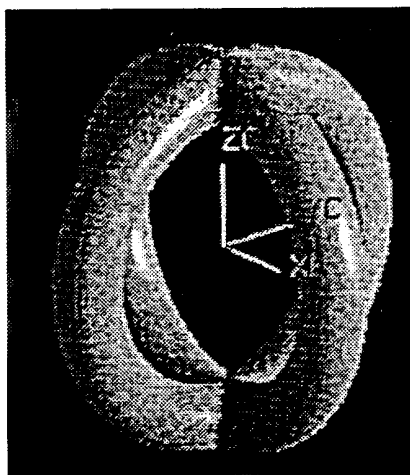

Fig. 6B

10/13

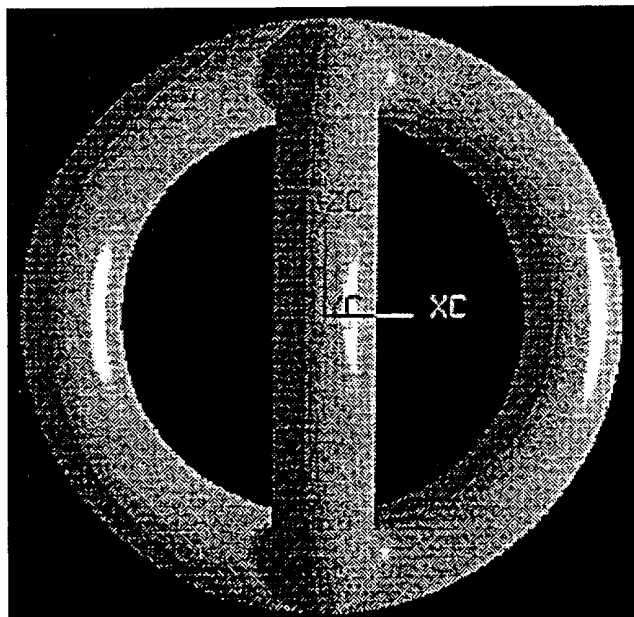

Fig. 6C

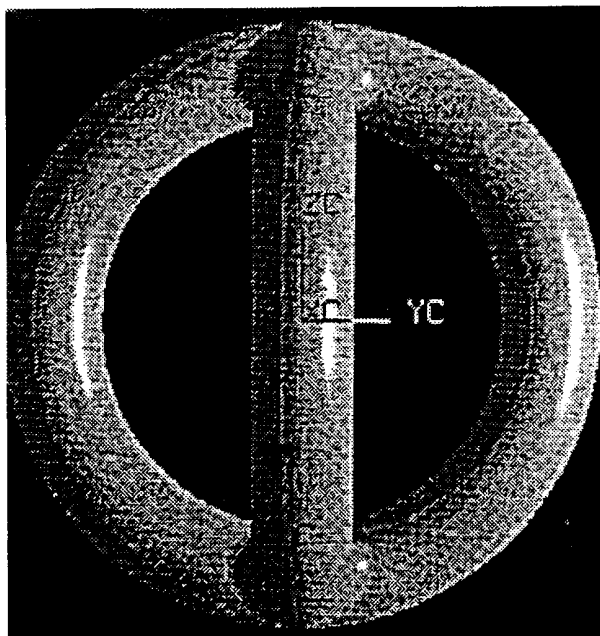
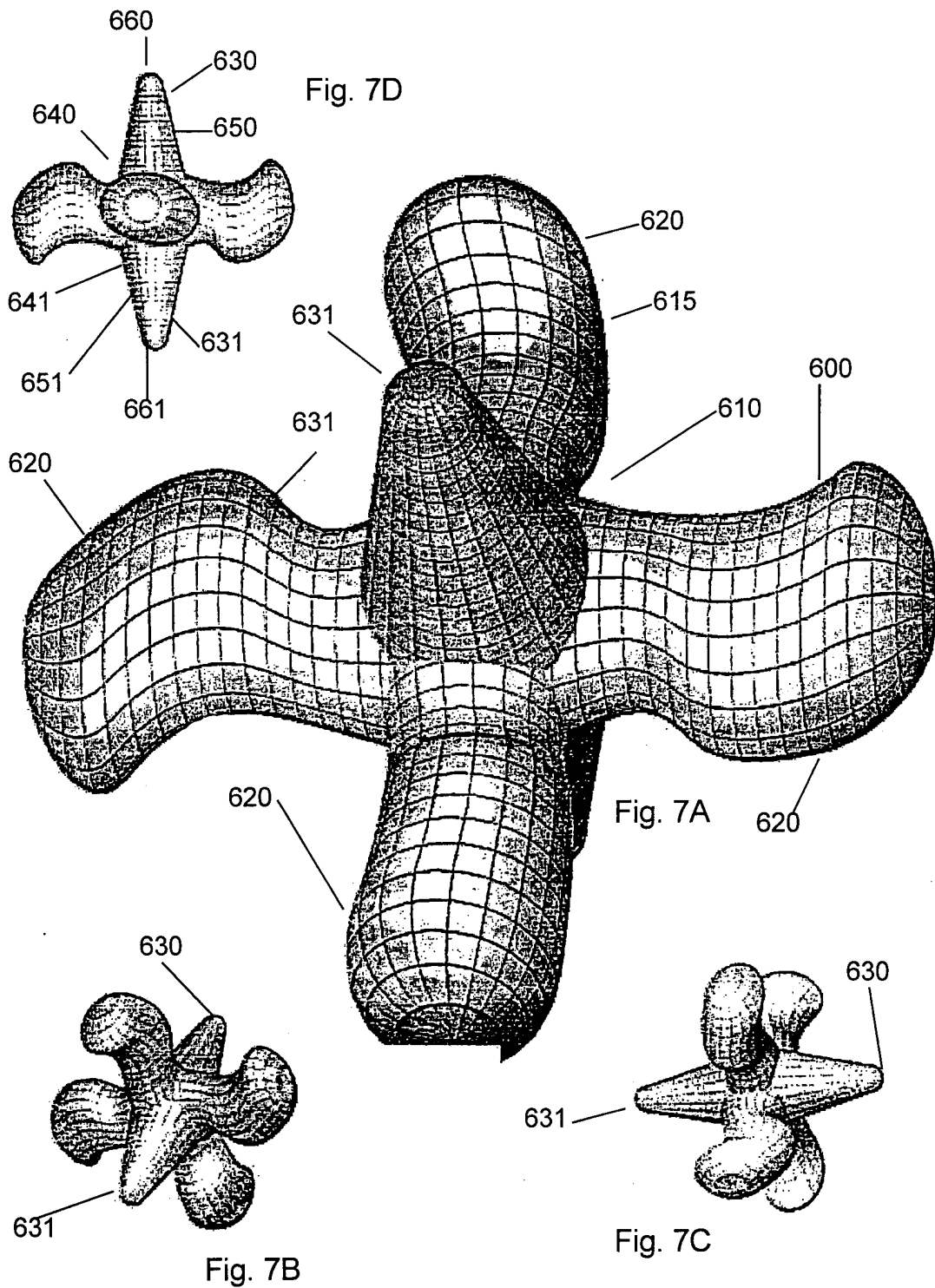

Fig. 6D



12/13

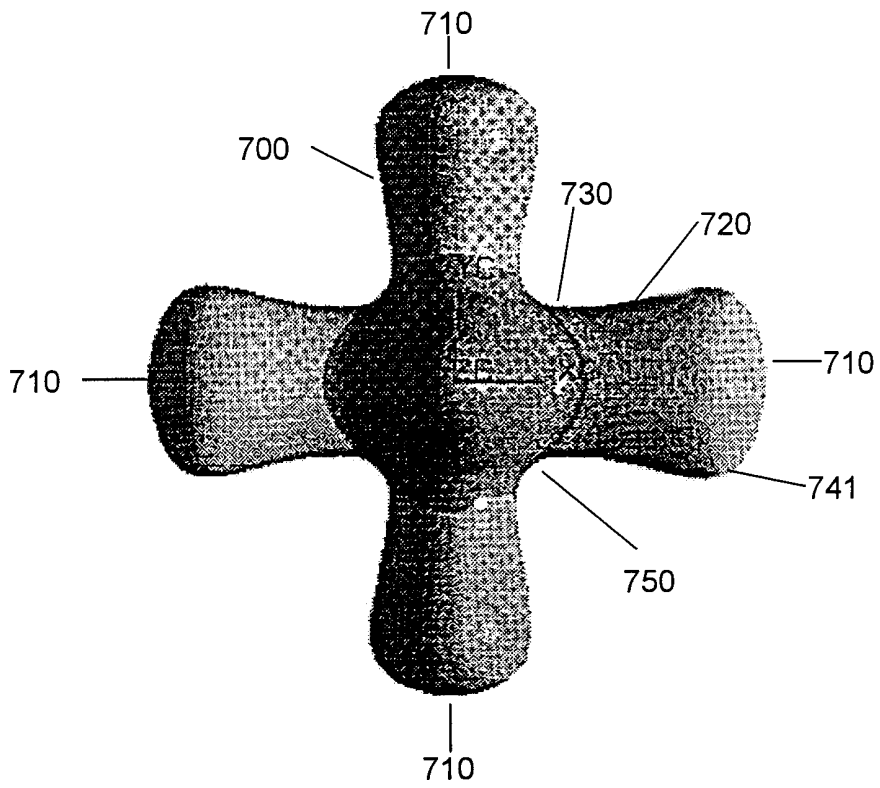

Fig. 8A

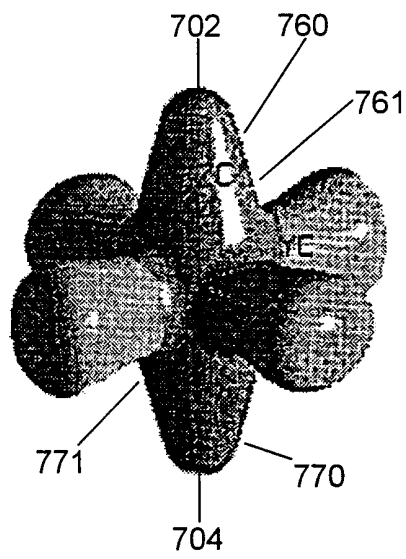

Fig. 8B

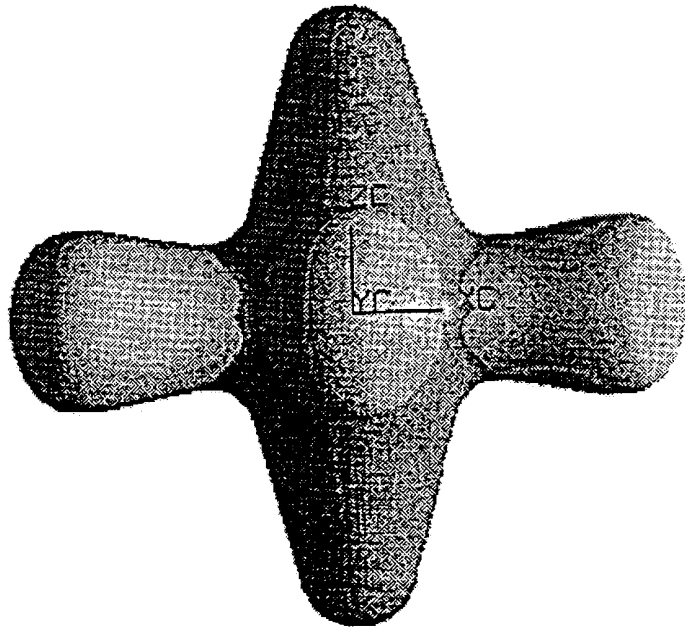

Fig. 8C

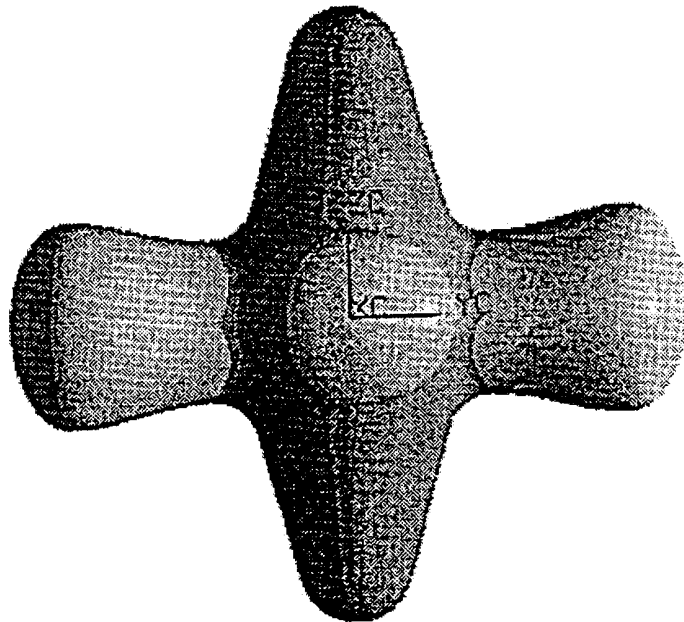

Fig. 8D