

(No Model.)

N. LOMBARD.  
LASTING MACHINE.

No. 524,447.

Patented Aug. 14, 1894.

Fig. 1.

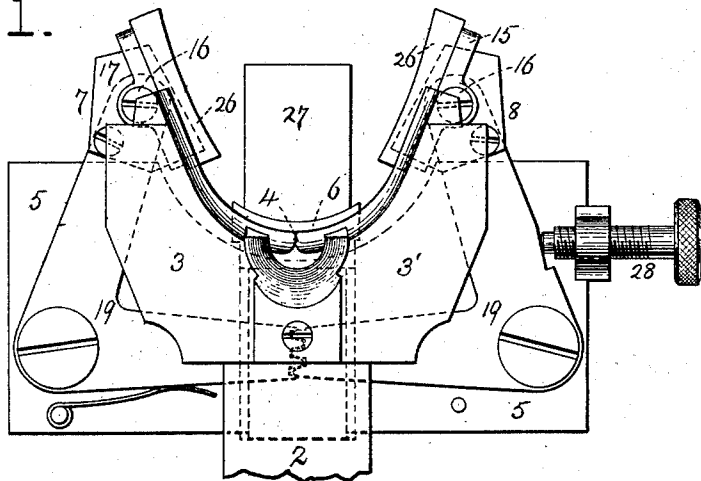

Fig. 2.

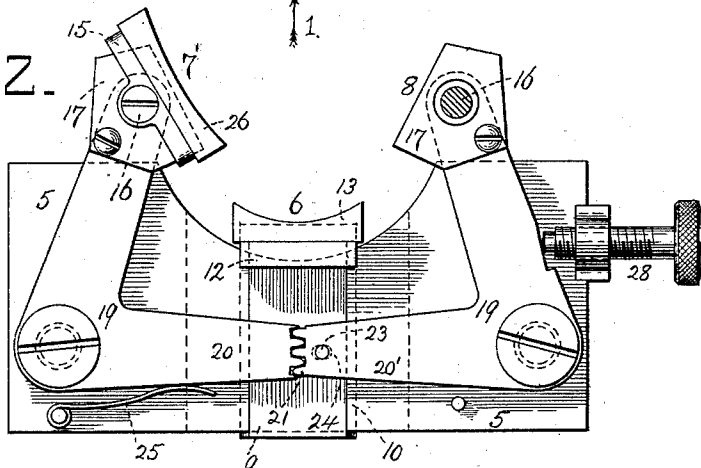

Fig. 3.

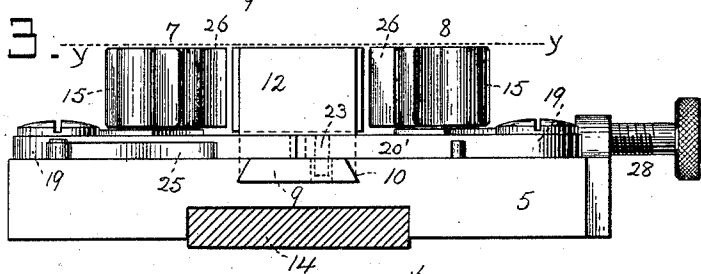
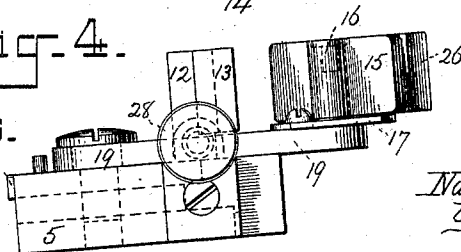

Fig. 4.



Witnesses.

*John F. Nelson*  
*F. C. Stanwood*

Inventor.

*Nathaniel Lombard*  
*By H. C. Lodge Atty.*

# UNITED STATES PATENT OFFICE.

NATHANIEL LOMBARD, OF BOSTON, MASSACHUSETTS.

## LASTING-MACHINE.

SPECIFICATION forming part of Letters Patent No. 524,447, dated August 14, 1894.

Application filed January 22, 1894. Serial No. 497,598. (No model.)

*To all whom it may concern:*

Be it known that I, NATHANIEL LOMBARD, a citizen of the United States, residing at Boston, in the county of Suffolk and State of Massachusetts, have invented certain new and useful Improvements in Lasting-Machines; and I do hereby declare the following to be a full, clear, and exact description of the invention, such as will enable others skilled in the art to which it appertains to make and use the same, reference being had to the accompanying drawings, and to figures of reference marked thereon, which form a part of this specification.

This invention has reference to a device employed in lasting machines to clasp or clamp either the heel or toe portion of the last and adjust and retain it in position, while the wipers, so called, perform the duty of lasting, which act consists in drawing and crimping the upper about said heel or toe portion.

My invention consists in a three part device, comprising a central piece or clamp for the extremity of the heel or toe, and two lateral clasps for the adjacent side parts. Furthermore this clamping device is automatic with respect to its powers of accommodation to fit any size and shape of heel or toe in a boot or shoe. Moreover the adjustment of the side clamp is dependent upon the movement of the central or end clamp. In this way the inconvenience occasioned by manual adjustment is obviated.

The drawings represent in Figure 1. a plan of a clamping device for the heel or toe portion of a lasting machine embodying my invention. Fig. 2 is likewise a plan the wipers being omitted. Fig. 3 is a rear elevation. Fig. 4 is a side elevation.

In said drawings I have shown only such parts of a lasting machine, as have direct relation to or are connected with the clamping device containing my invention. At 2 is indicated a portion of a plate adapted for sliding movement longitudinally of the last; upon this plate are mounted wipers 3, 3', which rock about a central point 4. Moreover these wipers are adjusted in a plane position above the top edges of the clamping device, the under surface of said wipers being very nearly coincident with the plane  $y y$ ,

shown in Fig. 3. Beneath the wipers and their operating mechanism is arranged a U shaped or horse-shoe shaped plate 5 adapted to admit the toe or heel portion of a shoe within it, while mounted thereupon is the clamping device. This as before mentioned comprises three parts, an end clamp 6 and two side clasps 7, 8 which are arranged and operated as follows: The central clamp or that adapted to contact with the extremity of the heel or toe is composed of a sliding plate 9 operating in an undercut groove 10 formed in the upper surface of the supporting plate 5; this latter is made fast to a portion 14 of a movable carriage (not shown) constituting a part of a lasting machine. Upon the front end of said plate 9 of the clamp and transversely thereof is attached an offset 12, the inner surface of which or that adjacent to the shoe is faced with leather, rubber or other similar material 13 to prevent injury to the leather of the upper, when such rests against it. Preferably this cushion is curved to conform more nearly to the shape of the toe or heel at this particular point.

The two side clasps are identical in shape and construction, and each comprises a block 15 set on edge and loosely mounted upon a stout pin 16; this latter is vertically affixed in the free end of an oscillating bifurcated lever 19, which is pivoted to the U plate. Beneath said block and between the latter and the lever is a removable plate 17, this plate is to extend under and support the soft material with which said block is faced, and thus prevents such material when pressure is applied from projecting down below the under surface of the block. Simultaneous movement and action of these side clasps toward or from the last is effected by means of the advance or retreat motion of the end clamp, and such is effected by extending the ends 20, 20', of the levers, so that the teeth 21 with which they are furnished shall interlock after the manner of gears. Furthermore one of said levers is attached to the plate 9 by means of a stud 23, which is fast in said lever and moves in a slot 24 in said plate to provide for the circular motion of the lever arm.

A spring 25 or its equivalent serves to hold

the side clamps in an open position ordinarily, while an adjusting screw-threaded bolt 28 serves to limit the retreat movement of the clamps to suit the varying shapes and styles of heels and toes. Similarly with the end clamp soft material is affixed to the inner faces of the side clamps, as shown at 26.

The support for the last from beneath is shown at 27, as adapted for the toe of the boot or shoe. Thus in the operation of this clamping device the last with the upper is adjusted between the heel and toe end clamps 6, when the carriage (not shown) is advanced in the direction of arrow 1. to bring the said clamp against the ends of the last. As a result this movement of the carriage causes the plate 9 of said end clamp to advance until stopped by its meeting with toe or heel of the shoe. At the same time the continued forward movement of the plate 5 compels the side clamps 7, 8. to advance laterally toward the last and grip the latter. After these side clamps have been brought firmly against the last any retreat movement of the end clamp from the heel or toe is prevented since the plate 9 is now being held by the stud 23 in the end of one of the lever arms. The several elements of this clamping device are now held firmly interlocked, until retreat of the carriage effects release of the parts. The holding force can be graduated by the operator and is dependent upon the thrust exerted by the central or end clasp against the extremity of last, either heel or toe. By this interlocking arrangement of the operating levers of the side clamps, an equal and opposite force is exerted upon the last and the upper is held firmly, while the last itself is maintained in a proper axial alignment, and cannot be thrust too much one way or the other laterally. Moreover this clamping device is automatically self-adjusting, and the use of springs and other mechanism for operating them is avoided.

45 What I claim is—

1. The clamping device for the heel or toe portion of a last and comprising a movable end clamp, two interlocking side clamps adapted to oscillate, and means for uniting 50 the interconnected side clamps positively with the end clamp, whereby contact of the end clamp against the last causes the side

clamps to approach said last, substantially as and for the purposes explained.

2. The combination with an adjustable supporting plate, and an end clamp thereupon adapted to slide longitudinally of the last, two similar side clamps, two operating levers secured to the supporting plate and which carry the side clamps, and interlocking mechanism for direct communication between the side clamps and end clamps by which movement of the end clamp serves to rock the side clamps, substantially as described. 65

3. In combination with a supporting plate, a sliding end clamp thereupon, two rocking levers pivoted on said plate, and having their adjacent arms interlocked, two side clamps loosely mounted on the opposite arms of said levers, and mechanism for positively uniting the sliding end clamp with the rocking levers to prevent movement of said end clamp after contact of the side clamps against the last, substantially as described. 75

4. In combination with a U plate adjustable longitudinally of a last, two bifurcated levers adapted to rock upon said plate, two clamps pivotal in horizontal planes upon the free ends of said levers, a series of teeth which interlock the adjacent ends of the levers, an end clamp to slide in the U plate, means to unite the interlocked ends of said levers with the end clamp, and mechanism to produce and limit the retreat action of the clamps, 85 substantially as stated.

5. The combination with a movable carriage, a pair of folding wipers thereupon, and means for operating said wipers, of an independently movable U plate, a pair of interlocking bifurcated levers thereupon, pivotal clasps affixed to the free ends of said levers, an end clasp adapted for sliding movement in the U plate, and means for uniting the levers with the end clasp whereby movement 95 of the said end clasp will produce simultaneous movement of the side clasps, substantially as set forth and specified.

In testimony whereof I affix my signature in presence of two witnesses.

NATHANIEL LOMBARD.

Witnesses:

FRANCIS C. STANWOOD,

H. E. LODGE.