

A. SINCLAIR.
LOOM FOR WEAVING CHENILLE FABRICS.

No. 446,896.

Patented Feb. 24, 1891.

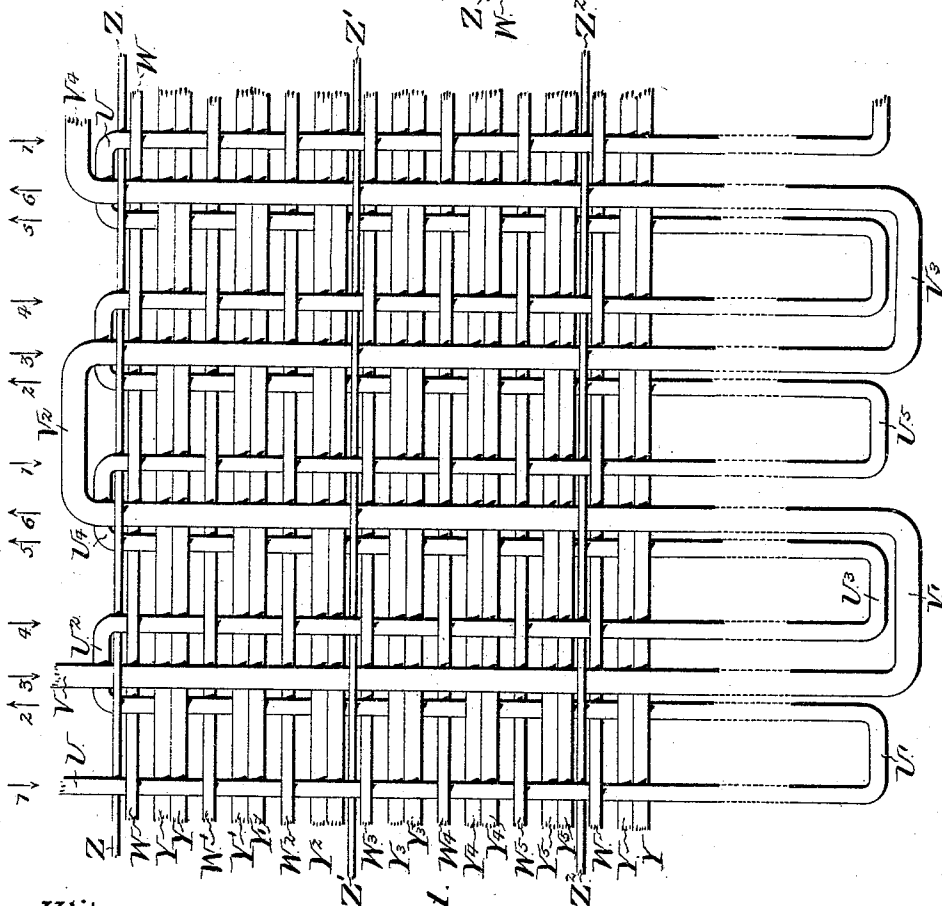
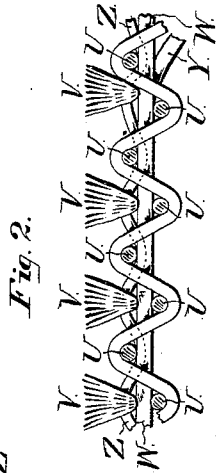

Witnesses:
W. H. Dillingham
Joshua M. Mack, Jr.

Inventor
Alexander Sinclair
 by his attorney
Fleming T. Chambers

A. SINCLAIR.
LOOM FOR WEAVING CHENILLE FABRICS.

No. 446,896.

Patented Feb. 24, 1891.

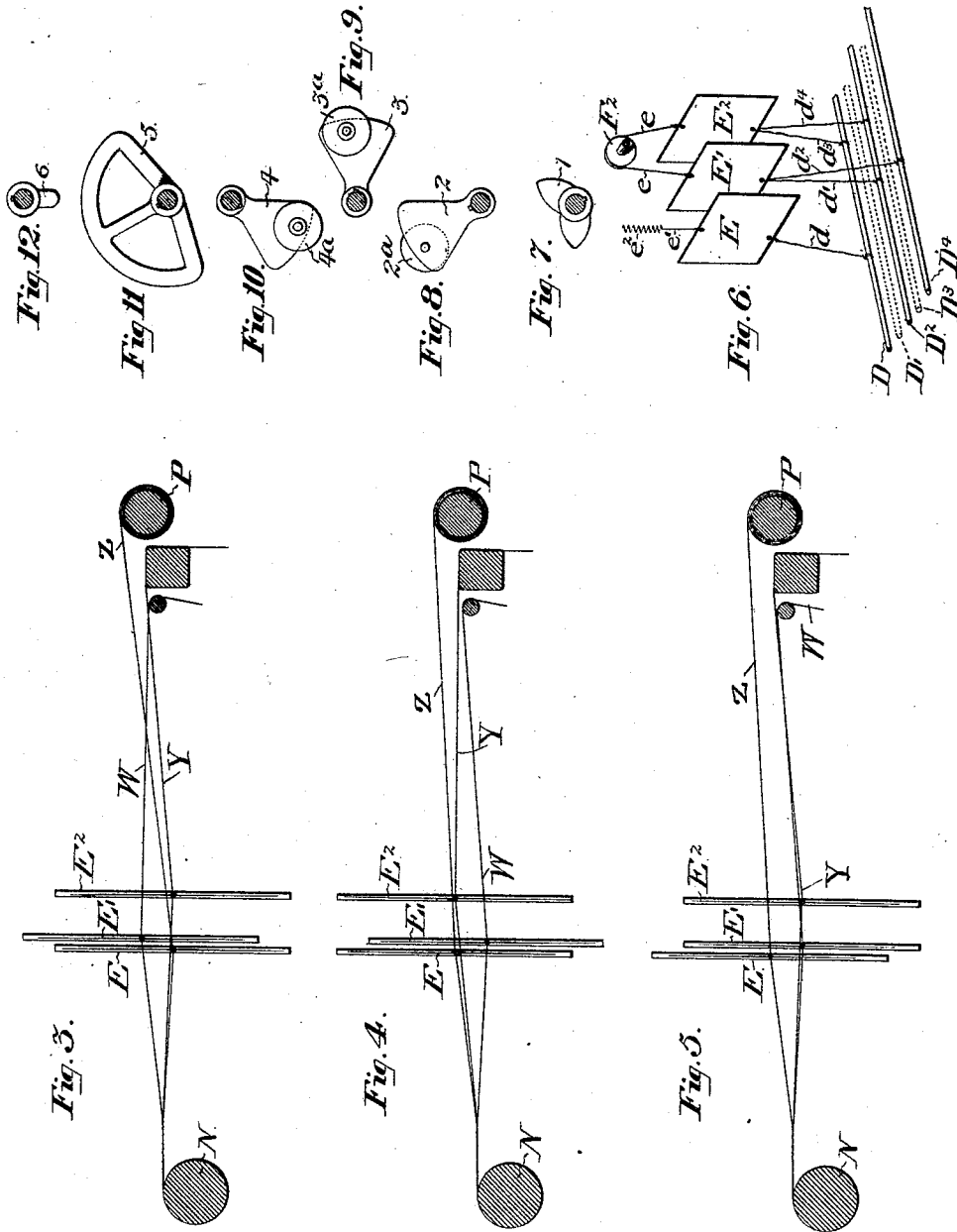

Witnesses:
Wm Dillingham
Joshua Matlack, Jr.

Inventor
Alexander Sinclair
 by his attorney
Francis T. Chamberlain

A. SINCLAIR.

LOOM FOR WEAVING CHENILLE FABRICS.

No. 446,896.

Patented Feb. 24, 1891.

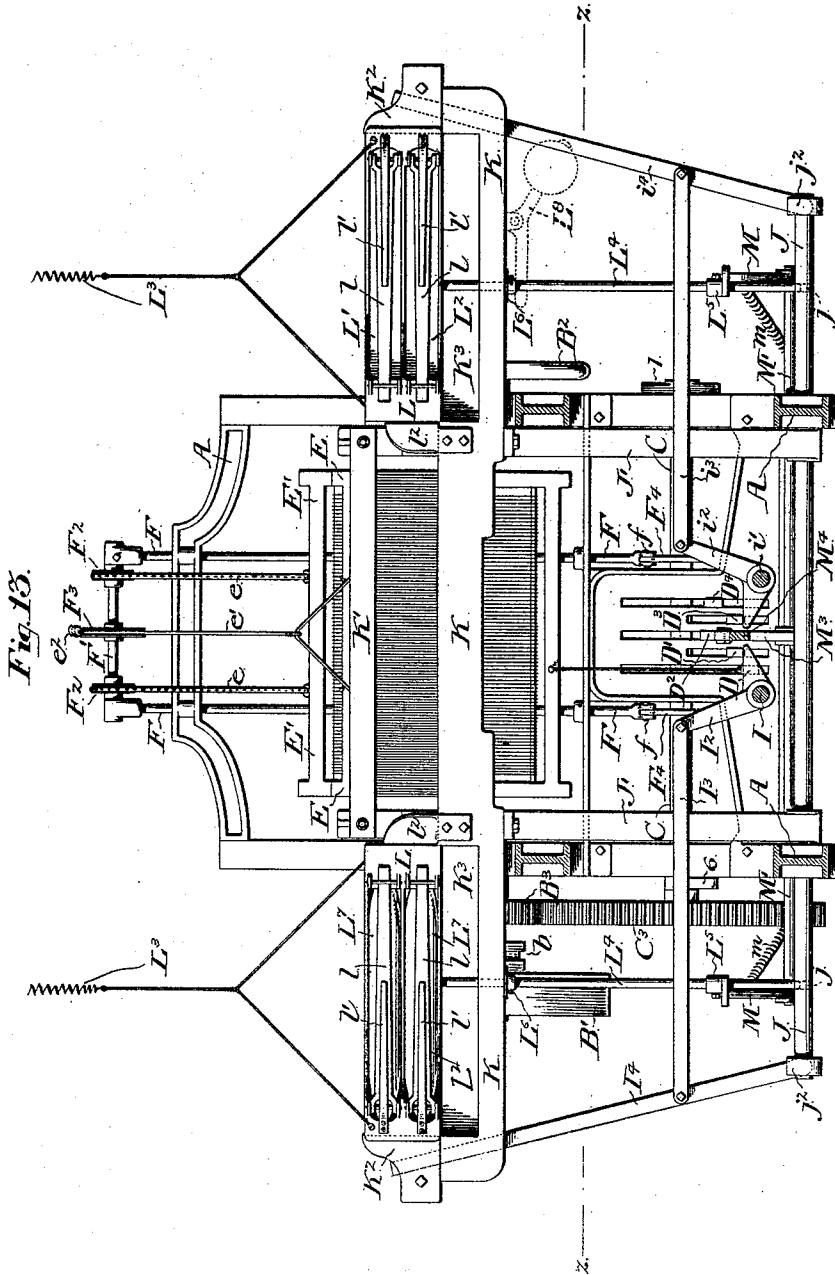

Fig. 13.

Witnesses:

W. H. Dillingham
Joshua Matlack, Jr.

Inventor

Alexander Sinclair
by his attorneys
Francis T. Chamberlain

A. SINCLAIR.
LOOM FOR WEAVING CHENILLE FABRICS.

No. 446,896.

Patented Feb. 24, 1891.

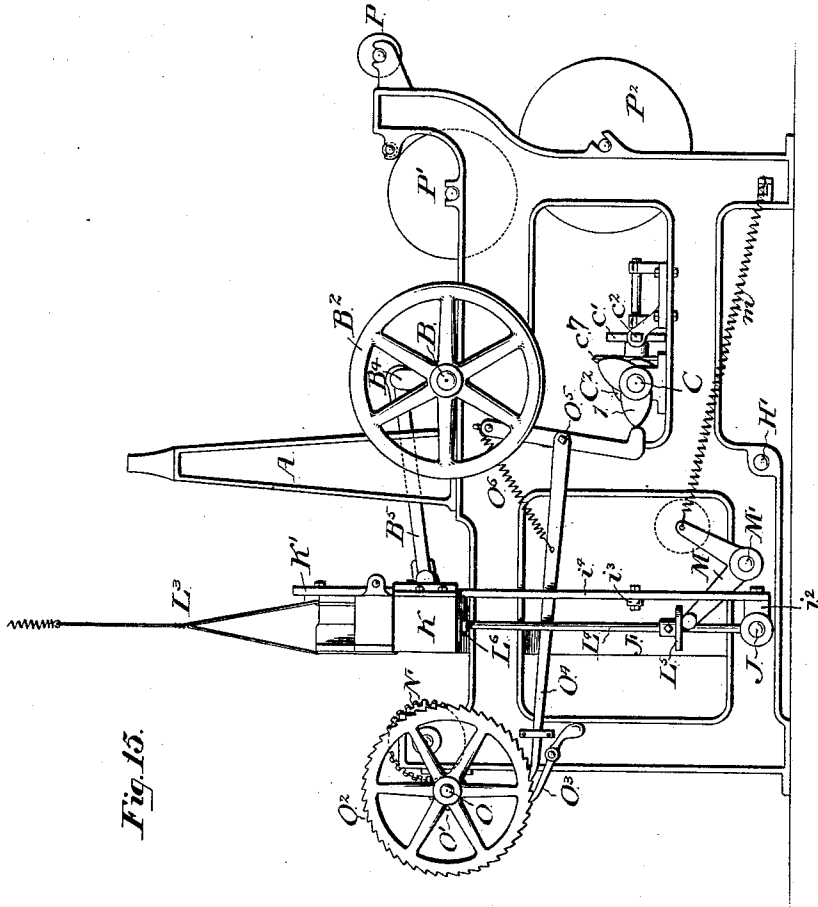

Fig. 13.

Witnesses:
Wm Dillingham
Joshua Matlack, Jr.

Inventor
Alvanor Sinclair
by his attorney
Jimmie T. Chambers

A. SINCLAIR.

LOOM FOR WEAVING CHENILLE FABRICS.

No. 446,896.

Patented Feb. 24, 1891.

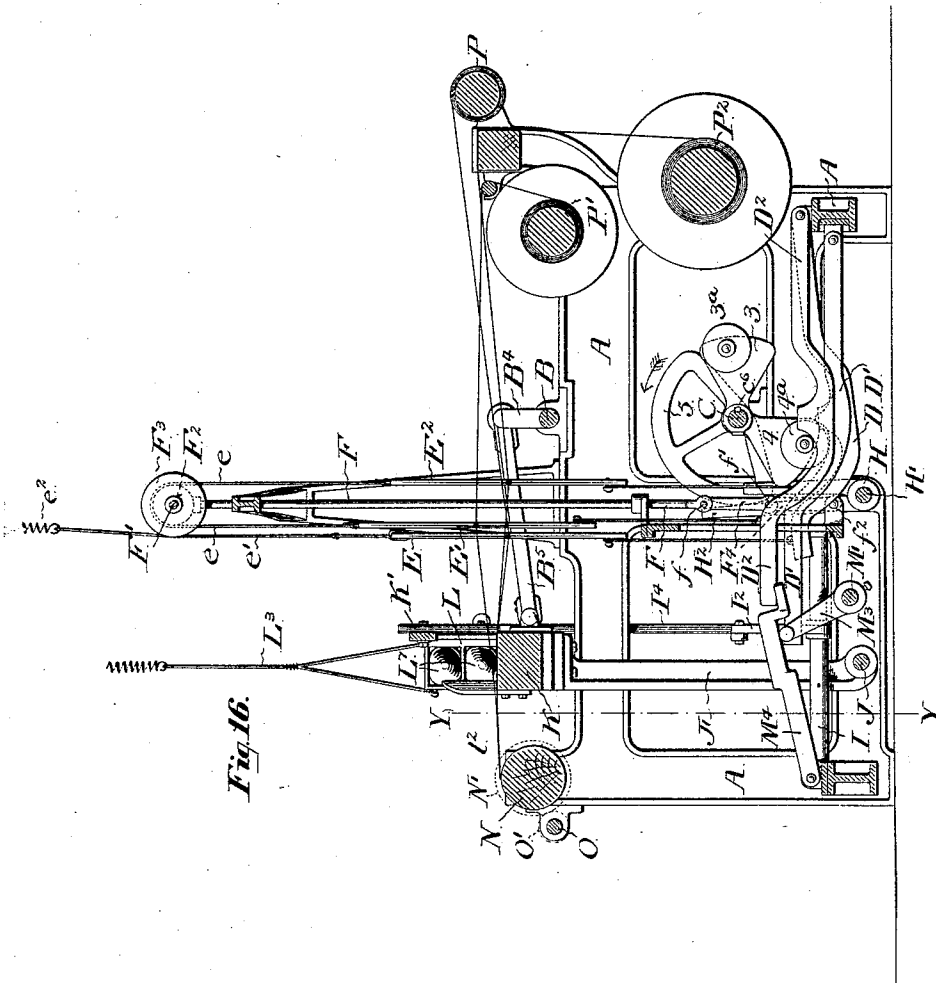

Fig. 16.

Witnesses:

W. H. Dillingham
Joshua M. Black, Jr.

Inventor

Alexander Sinclair
 by his attorney
Jimmie T. Chambers

A. SINCLAIR.

LOOM FOR WEAVING CHENILLE FABRICS.

No. 446,896.

Patented Feb. 24, 1891.

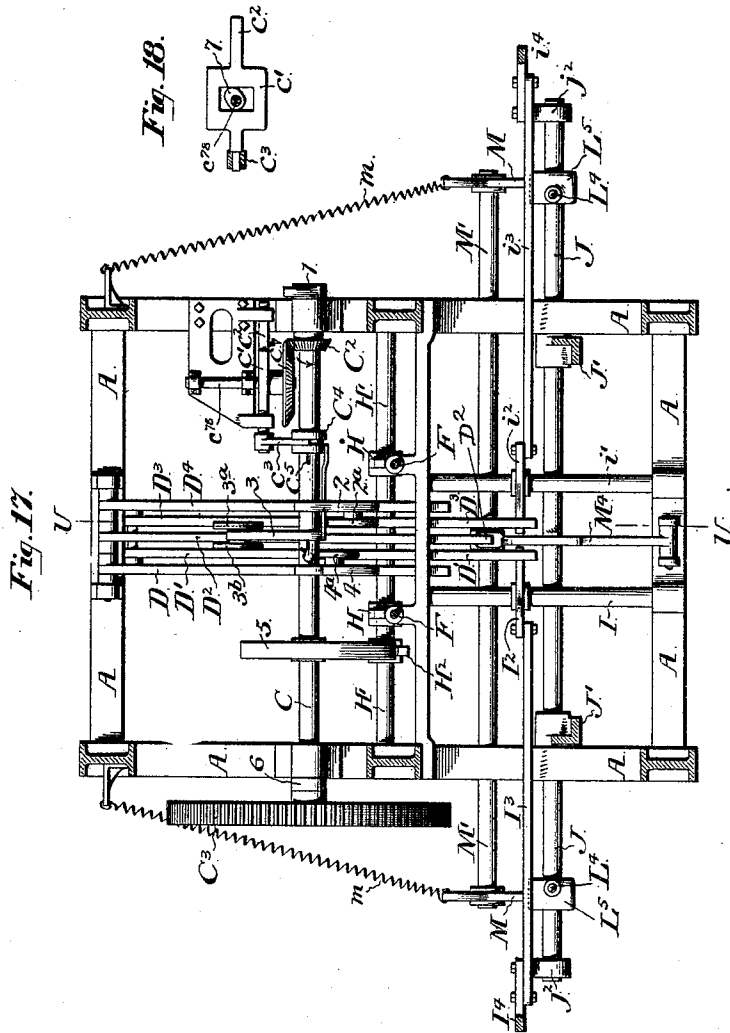

Witnesses:
W. H. Buckingham
Joshua M. Mack, Jr.

Inventor
Alexander Sinclair
 by his attorney
James T. Chamberlain

A. SINCLAIR.
LOOM FOR WEAVING CHENILLE FABRICS.

No. 446,896.

Patented Feb. 24, 1891.

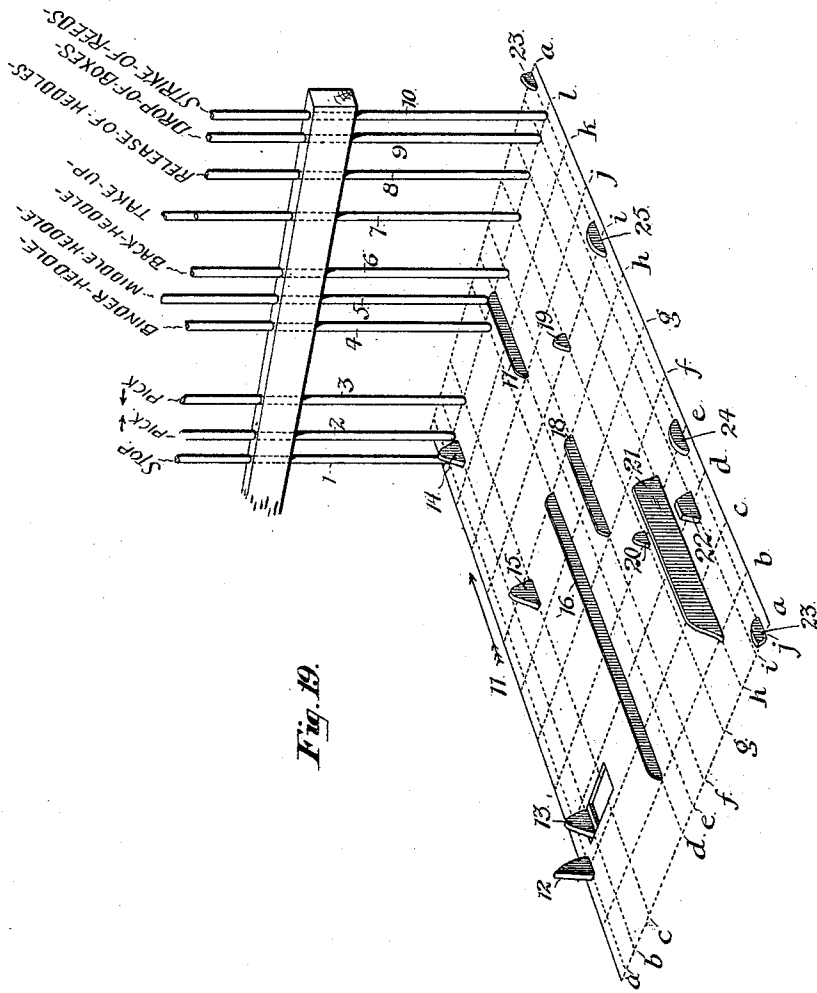

Fig. 19.

Witnesses:

W. H. Dillingham
Joshua M. Mack, Jr.

Inventor

Alexander Sinclair
by his attorney
Francis T. Chambers

UNITED STATES PATENT OFFICE.

ALEXANDER SINCLAIR, OF BIRMINGHAM, ASSIGNOR TO THE ROYAL AXMINSTER CARPET COMPANY, OF CAMDEN, NEW JERSEY.

LOOM FOR WEAVING CHENILLE FABRICS.

SPECIFICATION forming part of Letters Patent No. 446,896, dated February 24, 1891.

Application filed January 23, 1890. Serial No. 338,389. (No model.)

To all whom it may concern:

Be it known that I, ALEXANDER SINCLAIR, of Birmingham, county of Burlington, State of New Jersey, have invented a new and useful Loom for Weaving Chenille Fabrics, of which the following is a true and exact description, reference being had to the accompanying drawings, which form a part of this specification.

My invention relates to the construction and operation of looms for weaving chenille fabrics, and my improvements particularly relate to the operation of a power-loom to produce what is known as "Axminster carpet."

The novel features of my invention are hereinafter clearly pointed out in the claims, and will be described in connection with the apparatus as a whole with reference to the drawings, which represent a carpet-loom embodying my improvements.

In the said drawings, Figure 1 is a diagram showing the construction of the carpet my improved loom is adapted to make, being a carpet from the upper face, Fig. 2 being a similar diagram on a cross-section line of Fig. 1. Figs. 3, 4, and 5 are diagrams showing the relative motion of the heddles carrying the warp and binder threads. Fig. 6 is a diagram showing the connection of the heddles with the levers which actuate them. Figs. 7 to 12, inclusive, are views of the cams used by me in the loom, as shown in the drawings, to give the hereinafter-described motions to the parts they act upon. Fig. 13 is a front elevation of the loom on the section-line Y Y of Fig. 16. Fig. 14 is a side elevation viewed from the left of Fig. 13, and Figs. 14^a and 14^b show details of the clutch mechanism. Fig. 15 is a side elevation viewed from the right of Fig. 13. Fig. 16 is a side elevation viewed from the right on the section-line U U of Fig. 17. Fig. 17 is a plan view on the section-line z z of Fig. 13. Fig. 18 is an elevation of the sliding bar and cam-yoke acted on by cam 7, and Fig. 19 is a diagram which I will have occasion to refer to as illustrating some of the principles of my improved mechanism.

A indicates the framing of the loom, B is the driving-shaft, B' the driving-pulley jour-

naled on shaft B and preferably connected and disconnected with it by means of a clutch, Figs. 14 and 14^a, which and the mechanism for actuating it will be hereinafter described.

B² is a hand-wheel, and B³ a gear-wheel, both secured on the shaft B.

B⁴ are crank-arms on shaft B, and B⁵ connecting-rods jointed to the lay K.

C is a shaft driven from shaft B by means of a gear-wheel C³, which engages with gear B³, to which it bears the ratio of three to one.

On the shaft C, I secure the cams 1, 2, 3, 4, 5, and 6, as is shown in Figs. 17, 16, 15, and 14, the said cams in the position of the shaft indicated occupying the angular positions in which they are shown in Figs. 7 to 12.

Rollers 2^a, 3^a, 3^b, and 4^a are secured on cams 2, 3, and 4, as shown in Figs. 8, 9, 10, and 17, for the purposes hereinafter described.

I will say here, to prevent misconception, that the form of cams and of the surfaces acted on by them is not of the essence of my invention, as of course they may be modified in shape without materially or at all changing their mode of action.

D, D', D², D³, and D⁴ are levers or treadles pivoted at one end to the frame, as shown, and E E' E² are heddles, E having the binder-threads looped to it, and E' E² carrying the threads of the warp proper.

d, d', d², d³, and d⁴ (see Fig. 6) are chains connecting the heddles and treadles, as is shown in said figure.

The heddles E' E² are connected together by cords e passing over pulleys F², which are journaled on a shaft F', said shaft being supported on a frame composed of rods F F, which are secured in bearings in frame A, which permit them to move longitudinally. At their lower ends the rods F F are pivoted to links F⁴, forming a toggle-joint. (See Fig. 16.) The heddle E is supported by means independent of the rods F. As shown, its sustaining-cord e' is secured to a spring e², permanently secured to some stationary object. The cord e' engages a guide-wheel F³ on shaft F', but is not sustained upon it.

H H are levers resting against the knuckles f' of the toggle-joints which support the rods

F. These levers are secured to a shaft H', on which is also secured a lever H², which rests in contact with cam 5 and causes the shaft H' to oscillate as said cam revolves and the levers H to move out, so as to permit the toggle to bend out and then move in, causing it to straighten up, thus alternately permitting the rods F F, with the heddles which they sustain, to move down and forcing them up again. The arrangement by which the harness embracing the warp-heddles proper is moved up and down as a whole, while the binding-thread heddle remains unaffected by their motion, is an important feature of my invention.

I' I' are rocker-shafts on which are pivoted bell-crank levers I² I², from the outer ends of which extend connecting-rods I³ I³, which actuate the pickers I⁴ I⁴. The lower ends of the picker-levers I⁴ I⁴ are pivoted on arms j² j², extending out from a rock-shaft J, on which shaft are also secured the supports J' J', which sustain the lay K and its attached mechanism, all of which is given a reciprocating motion by means of connecting-rods B³ and cranks B¹, as already pointed out.

K' is the reed-frame; K² K², guides for the shuttle-frames.

K³ K³ are recesses for the shuttle-box to move up and down in.

L L are the shuttle-boxes situated at each side of the lay K and sustained on rods L⁴ L⁴, which at their lower ends have bearings j j in the rock-shaft J. On the rods L⁴ collars L⁶ are secured to prevent the rods and shuttle-boxes from being moved upward beyond a determined line, and projecting lugs L⁵ are also secured to the rods. The boxes L are made in two divisions L' L², Fig. 13, one above the other, and each adapted to contain a shuttle. Shuttles marked L' L' are represented as in the box to the left of Fig. 13.

l l are thin strips of wood, and l' l' springs pressing such strips inward, so that they will press against the shuttles L' in the boxes L' L² and act to prevent them bounding back when thrown into the boxes. The lower boxes L² are intended to contain the ordinary or binder weft-thread shuttles, and as shown in Fig. 13 they are in position to bring the shuttles in them in reach of the picker-arms. The upper boxes L' contain the chenille shuttles and are brought in reach of the pickers by moving the box L down into the cavity K³, so that the upper box will occupy the place filled by the lower one in the drawings.

A spring L³ or an equivalent device—such as the weight shown in dotted lines at L³, Fig. 13—may be conveniently used to sustain a portion of the weight of the boxes.

M M are bell-crank levers, the forward ends of which rest beneath the lugs L⁵ on the rods L⁴, the said levers being secured to a rock-shaft M', on which is also secured a lever M³, which is actuated by the lever or treadle D². As shown, said lever D² rests on the end of a lever M⁴, which is pivoted to the

frame and rests in its turn on the arm M³, (see Fig. 16,) the treadle D² being acted on by cam 3, and the shaft M' with its arms being kept normally in the position shown in the drawings, so as to keep the boxes L in their upper positions by a yielding force, such as a spring, as shown at *m m*.

To return to the mechanism for actuating the picker-arms, the levers I² I² are actuated by treadles D' D³, which in turn are actuated by the rollers 4^a of cam 4 and 2^a of cam 2, and also by the rollers 3^a and 3^b of cam 3, as will be hereinafter described.

I will here state that the device of making the double shuttle-boxes L vertically movable in the lay and actuating them in the way which will be specified is a very important feature of my invention.

The cam 3 is keyed to shaft C by means of a slot C⁶, Fig. 17, and is connected with a similarly-secured collar C⁴, having lateral motion in a slot C⁵. The object of this is to enable the cam 3 to move to and fro along shaft C so as to engage alternately treadles D' and D³ with its rollers 3^a and 3^b, the cam itself always working against treadle D². This motion is given it by means of the bevel gear-wheel C² on shaft C, which engages a gear-wheel C⁷ of double the diameter of wheel C², journaled in the frame and having on its shaft c⁷ a cam 7. (See Fig. 18.) A yoke C', attached to a rod C³, surrounds this cam, the rod having bearings in the frame and an arm C³ extending out from it and engaging the sliding collar C⁴. In this way cam 3 is moved to engage treadles D' or D³ at each revolution of shaft C and alternately.

N is the carpet-roll, on the shaft of which is a gear-wheel N', which engages a gear O' on shaft O.

O² is a ratchet-wheel on shaft O.

O³ is a detent-pawl engaging the ratchet.

O⁴ is a toothed rod for actuating the ratchet. This rod O⁴ is attached to a lever O⁵, which is pivoted at its upper end to the frame and has its lower end shaped and arranged to come in contact with and be actuated by the double cam 1.

O⁶ is a spring acting to keep the point of actuating-rod O⁴ in contact with the ratchet-wheel, and also hold the end of lever O⁵ against the cam 1.

The peculiar take-up motion given to roll N is a feature of my invention.

Referring now to the clutch for connecting pulley B' with shaft B, (see Figs. 14 and 14^a,) the clutch shown consists of an elastic split rim b', secured to shaft B by arms b³ and fitting in the rim of pulley B'. A collar b, sliding on and turning with the shaft B, is provided with an arm b², having on its end a wedge which rests between the ends of the split ring b', so that when the collar b is moved toward the pulley B' the wedge will force the ends of the ring apart, causing it to expand and clutch the pulley by frictional contact, while when withdrawn the elasticity of ring

b' will cause it to close up, releasing the pulley. This clutch I have found satisfactory; but any convenient clutch may be used in its stead.

5 b^5 is a lever pivoted at b^4 and engaging the clutch-collar b at one end. The other end of this lever is attached to a spring-rod or shipper-handle b^6 , the spring of which is in a direction outward and to the left of the frame.
 10 This spring-lever rests in a detent-slot $b^8 b^9$ of a lug b^7 , Fig. 14^b, and its spring will act to keep it in either detent of the slot in which it may be placed. When resting in detent b^8 , it holds the rim b' in engagement with the
 15 pulley B' , and to unclutch the pulley B' it is only necessary to move lever b^6 rearward out of notch b^8 , when its spring will cause it to move out into detent b^9 , and acting through lever b^5 draw the collar b back from the pulley and release the clutch. The clutching and unclutching of pulley B' to shaft B can be done by hand and at will. In making Axminster carpet, however, it is desirable to stop the loom after each chenille thread is thrown
 25 in, and this I accomplish in the machine shown by connecting the spring-lever b^6 to the top of a lever b^{11} , pivoted at b^{12} by a rod b^{10} . The lower end of lever b^{11} is in the path of cam 6 on shaft C, and by its movement under the action of the cam the lever b^6 is drawn out of detent b^8 , and springs out to b^9 at the end of each revolution of shaft C, thereby stopping the machine.

Z, Figs. 3, 4, and 5, represents the binding-thread controlled by the heddle E.

W and Y are the warp-threads, controlled, respectively, by heddles E' and E^2 .

U, Figs. 1 and 2, represents the weft-thread; V, the chenille, the different picks being indicated by the numbers affixed.

40 In Fig. 1, Z Z' Z^2 represent the binding-threads in position, and the jute or other warp-threads are indicated by W and Y, W' and Y', &c.

45 In the diagram Fig. 19 I have represented the principal operations of the machine in a simple way. It may be taken as a cam-cylinder spread out flat, and having cams 12 to 25 formed upon its surface, as shown, their relative positions being indicated by the intersecting lines $a a b b$, &c. The sliding rods numbered 1 to 10 may be taken as each controlling the motion of an operative part of the machine. 1 regulates the stoppage of the machine and is situated over longitudinal line a . 2 and 3 affect the two picks. 4 controls the binder-heddle E; 5 and 6, the warp-thread heddles E' E^2 . 7 controls the take-up. 8 effects the simultaneous release or dropping of the warp-heddles. 9 regulates the movement of the boxes, and 10 the stroke of the reeds. Supposing the said plane or cylinder to be moved or rotated so as to pass in the direction of the arrow beneath the rods 1 to 10, it
 50 is seen that the first action is the elevation of the middle warp-heddle by cam 17 acting on

rod 5. Cam 14 then acts on rod 2, causing a pick or throwing across of the weft-thread. Next the cam 25, acting on rod 10, causes a stroke of the reeds, and at the same time
 70 cam 19, acting on rod 7, actuates the take-up. Cams 16 and 18 next act on heddle-rods 4 and 6, causing the elevation of their controlled heddles, the central heddle controlled by rod 5 being dropped, and cam 15, acting
 75 on pick-rod 3, causes a pick of the weft-thread to be made in the opposite direction from that caused by cam 14. Cam 18 then permits the back heddle to fall and cams 20, 21, and 24 come into action substantially at
 80 the same time, acting on rods 7, 8, and 10, causing a take-up, the dropping of the warp-heddles, and a stroke of the reeds. Cam 22 next acts on rod 9, causing the dropping of the double shuttle-boxes, and cam 13 then
 85 acts on rod 2, causing a pick to be made of the chenille-shuttle. The cam 16, it will be noticed, is continuously acting to hold the binder-heddle up until after the chenille is thrown under the binder-threads. In the machine as shown
 90 in the drawings the binder-thread heddle is normally in its uppermost position and its depression is effected by a cam; but for illustration in the diagram the plan adopted is taken as being more easily followed. The
 95 cam 12 then acts on rod 1, effecting a stoppage of the machine and giving the weaver time to properly adjust the chenille before the next stroke of the reeds, effected by cam 23 acting on rod 10. Cam 13 is shown as ad-
 100 justable between lines b and c , so that it can act in turn on rods 2 and 3, actuating one pick during the first cycle of movement and the other during the next, and so on.

The mechanism shown in the drawings is
 105 adapted to carry out the cycle of movements shown in the diagram, and I will now describe its operation, following the same order as shown in the diagram, Fig. 19, but beginning with the depression of the middle heddle E' and the simultaneous elevation of the heddles E E^2 , being the motion described in connection with the diagram Fig. 19 as effected by cams 16 and 18.

The driving-shaft C being set in operation
 115 by drawing the spring-lever b^6 back into the detent b^8 and by means of the lever b^5 , collar b , and wedge b^2 , spreading the split ring b' so as to engage the driving-pulley B' with the driving-shaft, the cam 4, Figs. 10, 16, and
 120 17, presses down the treadle D and by means of chains d and d^3 draws down the heddles E and E^2 , the downward movement of heddle E^2 drawing up heddle E' by means of the connection e , and the warp being then in
 125 the position shown in Fig. 3. The roller-cam 4^a then depresses lever D' , the end of which acts on bell-crank lever I^2 , pivoted on shaft I, and by means of rod I^3 causes the pick-lever I^4 to move sharply inward, its end striking
 130 against the shuttle in the lower box L^2 on that side of the machine and throwing it

across to the opposite lower box L^2 . At this point the lay moves back and the reeds push the weft-thread into place, this motion being accomplished by the rotation of the crank B^4 on shaft B, said crank being connected with the lay by rod B^5 , and the shaft C being rotated from shaft B by means of the gear-wheels B^3 and C^3 , bearing the ratio of 1 to 3, so that shaft B makes three rotations to one of the shaft C. At the same time with the stroke of the reeds the cam 1, Figs. 7, 15, and 17, acts on end of lever O, pushing the rod O^4 out and rotating ratchet-wheel O^2 and shaft O, thus effecting a take-up, the pawl O^3 holding the carpet-roll in position when rod O^4 releases the ratchet-wheel. The position of the machine and its parts as shown in the drawings is that resulting from the operations above described, except that, as shown, the stroke of the reeds is not completed. As the shaft C continues to revolve with its cams in the direction indicated by the arrows in Fig. 16, the cam 4 and the cam-roller 4^a release levers D and D' and the heddle E is drawn by the spring e^2 to its upper position. Then the cam 2 (see Figs. 8 and 17) depresses lever D^4 , drawing down heddle E' , and by means of connection e drawing up heddle E^2 , arranging the warp as shown in Fig. 4. The cam-roller 2^a then comes in contact with and depresses lever D^3 and effects a pick in the opposite direction through the mechanism corresponding to that effected by lever D, such mechanism operated by lever D^3 comprising bell-crank lever i^2 , rod i^3 , and picker-lever i^1 . The reeds now make another strike, and the second arm of cam 1 effects a second take-up, and the cam 2 and cam-roller 2^a release levers D^4 and D^3 . During all of the above-described operations the cam 5, Figs. 2, 16, and 17, acting through levers H, H^2 , and shaft H' , has maintained in the position shown in Fig. 16 the toggle-jointed levers F^4 , which support the frame $F F$; but the second pick having been made, said cam then, as shaft C revolves, allows the toggle-joint to move out and the heddle-supporting frame to fall, thus lowering the pulleys F^2 over which connections ee pass. Then the cam 3 comes in contact with the treadle D^2 , depressing it, thus in the first place, drawing down both heddles $E' E^2$ by means of chains $d' d^4$, Fig. 6, and bringing the warp-threads to the position shown in Fig. 5, and in the second place effecting the dropping of the shuttle-boxes as follows: Treadle D^2 overlaps and rests upon the end of lever M^4 , and lever M^4 rests on the end of crank-lever M^3 , which is attached to shaft M' , and therefore when treadle D^2 is depressed it effects a movement of rotation in shaft M' and causes the arms of bell-crank levers M, which rest against the plates L^5 , to fall, thus removing the support which holds the shuttle-boxes $L L$ in their uppermost positions and permitting them to fall to the bottom of the chambers $K K$, in which they are secured.

The roller-cam 3^a then depresses treadle D^3 , and, acting through bell-crank lever i^2 , rod i^3 , and picker-staff i^1 , throws the shuttle in the upper box L' across to the opposite box. The cam 3 is shifted longitudinally on shaft C, so as to bring roller-cam 3^a in contact with treadle D^3 at the proper time in the following manner: The cam 3 is connected to shaft C by means of a feather fitting in slot C^6 , and is rigidly connected to a collar C^4 by a rod, as shown. Collar C^4 is connected to shaft C by a feather fitting in slot C^5 , and by means of rod C^3 it is also connected to the reciprocating rod C^2 . This rod C^2 is actuated by cam 7, Fig. 18, the said cam being attached to the same shaft which carries miter-wheel C^7 , said wheel engaging wheel C^2 , which turns with shaft C and has half the diameter of C^7 . By this arrangement cam 3 is moved continuously in one direction during one revolution of shaft C and in the other direction during the next revolution. Thus the roller-cam 3^a is brought in contact with treadle D^2 at one revolution of the shaft C, and during the next revolution roller-cam 3^b comes in contact with treadle D' , the pick made by this last contact throwing back the upper or chenille-shuttle after a double pick of the weft-thread shuttle has taken place. To return to the first cycle of movements, after the roller 3^a has caused the pick, as described, the cam 6, Figs. 12 and 14, comes in contact with the end of lever b^{11} and presses it out, drawing the spring-lever b^5 out of detent-notch b^8 by means of rod b^{10} . The spring of lever b^6 causes it to pass to the end of notch b^9 , and in moving the said lever draws the wedge b^2 back by means of lever b^5 and collar b , causing the clutch-ring b' to release its hold on pulley B' and stopping the machine. This stoppage gives the weaver time to carefully adjust the chenille thread in proper position for the pattern and to comb it up, and having done this he starts the machine again by drawing the spring-lever b^6 into detent-notch b^8 and the reeds make their third stroke, pushing the chenille thread into place in the fabric. This completes the cycle of movements of the machine, all occurring in the construction shown during a single revolution of cam-shaft C or three revolutions of the driving-shaft B. The next cycle is exactly similar, with the single exception that the roller-cam 3^b comes into action, depressing treadle D' instead of roller-cam 3^a depressing treadle D^3 .

The specific mechanism described and shown by me is well adapted for use in my new combinations of acting parts, so far as the specific forms of the cams and arrangements of mechanism by which the cam is made to act on the desired element of the loom are concerned. They are of course capable of great changes and modifications without in any way changing the main features of my invention, and, save where the said mechanism is specifically referred to in the claims,

I do not wish to be understood as limiting the claims to its use.

It will be noticed that in the construction described the take-up only acts after each weft-thread proper is thrown in and not after the chenille thread is thrown. The reason for this will be apparent from a glance at Fig. 2, which shows that the chenille is by the stroke of the reeds pushed above the preceding weft-thread, and really does not add to the length of the carpet, being, as it were, sewed to the base formed by the warp and weft threads by means of the binder-threads.

Having now described my invention, what I claim as new, and desire to secure by Letters Patent, is—

1. In a loom, the combination of a vertically-movable heddle-supporting frame, two warp-thread heddles connected by cords or chains passing over and supported upon said frame, the said heddles being connected to have a relatively reciprocating motion as well as a conjoint upward and downward motion with the supporting-frame, a third heddle supported independently of the heddle-supporting frame and constructed to move up and down independently thereof, and mechanism for actuating the said heddles and heddle-frame, substantially as described.

2. In a loom, movable double shuttle-boxes arranged at each end of the lay, a pick-lever at each end of the lay, mechanism for actuating first one and then the other pick-lever consecutively, independent mechanism for actuating first one and then the other picker-staff, alternately arranged to act intermediately between each two pairs of consecutive strokes given by the mechanism first aforesaid, and mechanism for actuating the shuttle-boxes, arranged to bring one box of each in front of the picker-staffs during each alternate consecutive double stroke and to bring the other boxes to similar operative position at each intermediate single stroke of the pick-levers.

3. In a loom, the combination of two heddles sustaining warp-threads, supporting mechanism for said heddles, arranged, as described, to permit them to move up and down reciprocally and also together, a third heddle for supporting binder-threads, supported and operated independently of the warp-thread heddles, mechanism arranged to elevate and depress the heddles, as described, double movable shuttle-boxes at each end of the lay, mechanism for elevating and depressing said boxes, arranged to operate in connection with the heddle-actuating mechanism, as described, pick-levers, mechanism for actuating the same alternately after each reciprocal movement of the warp-thread heddles, and mechanism for actuating the same alternately after each simultaneous depression of said heddles.

4. In a loom, the combination of two heddles sustaining warp-threads, supporting mechanism for said heddles, arranged, as de-

scribed, to permit them to move up and down reciprocally and also together, a third heddle for supporting binder-threads supported and operated independently of the warp-thread heddles, mechanism arranged to elevate and depress the heddles, as described, double movable shuttle-boxes at each end of the lay, mechanism for moving and adjusting said boxes, arranged to operate in connection with the heddle-actuating mechanism, as described, pick-levers, mechanism for actuating the same alternately after each reciprocal movement of the warp-thread heddles, mechanism for actuating the same alternately after each simultaneous depression of said heddles, reeds, mechanism arranged to actuate the reeds after each pick, a carpet-roll, and take-up mechanism arranged to act on the roll after each of two consecutive picks and to remain inactive after the third.

5. In a loom, the combination of two heddles sustaining warp-threads, supporting mechanism for said heddles, arranged, as described, to permit them to move up and down reciprocally and also together, a third heddle for supporting binder-threads, supported and operated independently of the warp-thread heddles, mechanism arranged to elevate and depress the heddles, as described, double movable shuttle-boxes at each end of the lay, mechanism for moving and adjusting said boxes, arranged to operate in connection with the heddle-actuating mechanism, as described, pick-levers, mechanism for actuating the same alternately after each reciprocal movement of the warp-thread heddles, mechanism for actuating the same alternately after each simultaneous depression of said heddles, reeds, mechanism arranged to actuate the reeds after each pick, a carpet-roll, take-up mechanism arranged to act on the roll after each of two consecutive picks and to remain inactive after the third, the driving-shaft, a driving-pulley journaled on said shaft, a clutch connecting said shaft and pulley, and clutch-releasing mechanism arranged to act after each third pick and before the stroke of the reeds following it.

6. In a loom, a heddle-supporting frame F F' , in combination with a cam 5, arranged to elevate and depress said frame at regular intervals, warp-thread heddles E' E^2 , connected by a chain or chains e , passing over the frame, a binder-thread heddle E , supported independently of frame F F' , cams 2, 3, and 4, arranged as described, and means for transmitting motion connecting said cams with the heddles, as described, cam 2 acting to depress heddle E' and elevate heddle E^2 , cam 3 acting simultaneously with cam 5 to simultaneously depress heddles E' E^2 as the frame F F' falls, and cam 4 acting to depress heddle E and to depress heddle E^2 and elevate heddle E' , all in the order specified.

7. In a loom, the combination, with the lay, of double shuttle-boxes movable with refer-

ence to the shuttle-race, pick-levers arranged to act on the shuttle in the boxes registering with the race, means to elevate the shuttle-boxes, and a cam 3 to depress the same, independent mechanism for transmitting motion to each of the pick-levers, cams 3^a and 3^b, connected with cam 3, as specified, so as to act on the pick-lever-operating mechanism after cam 3 has changed the position of the shuttle-boxes, and cam-shifting mechanism arranged, as described, to bring said cams 3^a and 3^b into action alternately, one after each action of cam 3.

8. In a loom, the combination, with the lay, of double shuttle-boxes movable with reference to the shuttle-race, pick-levers arranged to act on the shuttles in the boxes registering with the race, means to elevate the shuttle-boxes and a cam 3 to depress the same, independent mechanism for transmitting motion to each of the pick-levers, cams 3^a and 3^b, connected with cam 3, as specified, so as to act on the pick-lever operating mechanism after cam 3 has changed the position of the shuttle-boxes, cam-shifting mechanism arranged, as described, to bring said cams 3^a and 3^b into action alternately, one after each action of cam 3, and cams 2^a and 4^a, arranged, as specified, to act on the mechanism for transmitting motion to the pick-levers and so as to operate the said levers alternately and consecutively between each action of cam 3 upon the mechanism for actuating the double shuttle-boxes.

9. In a loom, the combination, with the lay, of double shuttle-boxes movable with reference to the shuttle-race, pick-levers arranged to act on the shuttle in the boxes registering with the race, means to elevate the shuttle-boxes and a cam 3 to depress the same, independent mechanism for transmitting motion to each of the pick-levers, cams 3^a and 3^b, connected with cam 3, as specified, so as to act on the pick-lever-operating mechanism after cam 3 has changed the position of the shuttle-boxes, cam-shifting mechanism arranged, as described, to bring said cams 3^a and 3^b into action alternately, one after each action of cam 3, cams 2^a and 4^a, arranged, as specified, to act on the mechanism for transmitting motion to the pick-levers and so as to operate the said levers alternately and consecutively between each action of cam 3 upon the mechanism for actuating the double shuttle-boxes, heddles E' E², arranged to carry warp-threads, supporting mechanism arranged, as described, to permit said heddles to move reciprocally and also together, cams 2 and 4, arranged, as described, to give reciprocating motion to said heddles and to act only when cam 3 is out of operation and the shuttle-boxes are in normal position, a binder-thread heddle E, connections to said heddle, whereby it is depressed by cam 4, and mechanism connecting cam 3 with the heddles, as described, so as to depress them both when the shuttle-boxes are shifted.

10. In a loom, the combination, with the lay, of double shuttle-boxes adjustable with reference to the shuttle-race, pick-levers arranged to act on the shuttle in the boxes registering with the race, means to elevate the shuttle-boxes and a cam 3 to depress the same, independent mechanism for transmitting motion to each of the pick-levers, cams 3^a and 3^b, connected with cam 3, as specified, so as to act on the pick-lever-operating mechanism after cam 3 has changed the position of the shuttle-boxes, cam-shifting mechanism arranged, as described, to bring said cams 3^a and 3^b into action alternately, one after each action of cam 3, cams 2^a and 4^a, arranged, as specified, to act on the mechanism for transmitting motion to the pick-levers and so as to operate the said levers alternately and consecutively between each action of cam 3 upon the mechanism for actuating the double shuttle-boxes, heddles E' E², arranged to carry warp-threads, supporting mechanism arranged, as described, to permit said heddles to move reciprocally and also together, cams 2 and 4, arranged, as described, to give reciprocating motion to said heddles and to act only when cam 3 is out of operation and the shuttle-boxes in normal position, a binder-thread heddle E, connections to said heddle whereby it is depressed by cam 4, and mechanism connecting cam 3 with the heddles E' E², as described, so as to depress them both when the shuttle-boxes are shifted, reeds and mechanism for actuating the same after each pick, take-up mechanism, and a cam 1, arranged to actuate on the same after two consecutive picks and to remain inactive after the third pick made when cam 3 is in operation.

11. In a loom, the combination, with the lay, of double shuttle-boxes movable with reference to the shuttle-race, pick-levers arranged to act on the shuttle in the boxes registering with the race, means to elevate the shuttle-boxes and a cam 3 to depress the same, independent mechanism for transmitting motion to each of the pick-levers, cams 3^a and 3^b, connected with cam 3, as specified, so as to act on the pick-lever-operating mechanism after cam 3 has changed the position of the shuttle-boxes, cam-shifting mechanism arranged, as described, to bring said cams 3^a and 3^b into action alternately, one after each action of cam 3, cams 2^a and 4^a, arranged, as specified, to act on the mechanism for transmitting motion to the pick-levers and so as to operate the said levers alternately and consecutively between each action of cam 3 upon the mechanism for actuating the double shuttle-boxes, heddles E' E², arranged to carry warp-threads, supporting mechanism arranged, as described, to permit said heddles to move reciprocally and also together, cams 2 and 4, arranged, as described, to give reciprocating motion to said heddles and to act only when cam 3 is out of operation and the

shuttle-boxes in normal position, a binder-
thread heddle E, connections to said heddle
whereby it is depressed by cam 4, and mech-
anism connecting cam 3 with the heddles E'
5 E², as described, so as to depress them both
when the shuttle-boxes are shifted, reeds and
mechanism for actuating the same after each
pick, take-up mechanism, a cam 1, arranged
to actuate the same after two consecutive
10 picks and to remain inactive after the third

pick made when cam 3 is in operation, a driv-
ing-shaft, a driving-pulley journaled thereon,
a clutch securing the driving-pulley to the
shaft, clutch-releasing mechanism, and a cam
6, arranged to actuate such mechanism after 15
each pick made when cam 3 is in operation.

ALEXANDER SINCLAIR.

Witnesses:

LEWIS R. DICK,
JOSHUA MATLACK, Jr.