

Jan. 29, 1935.

B. POLLAK

1,989,426

CHAIR, TABLE, AND THE LIKE ADAPTED FOR STACKING

Filed Jan. 30, 1930

4 Sheets-Sheet 1

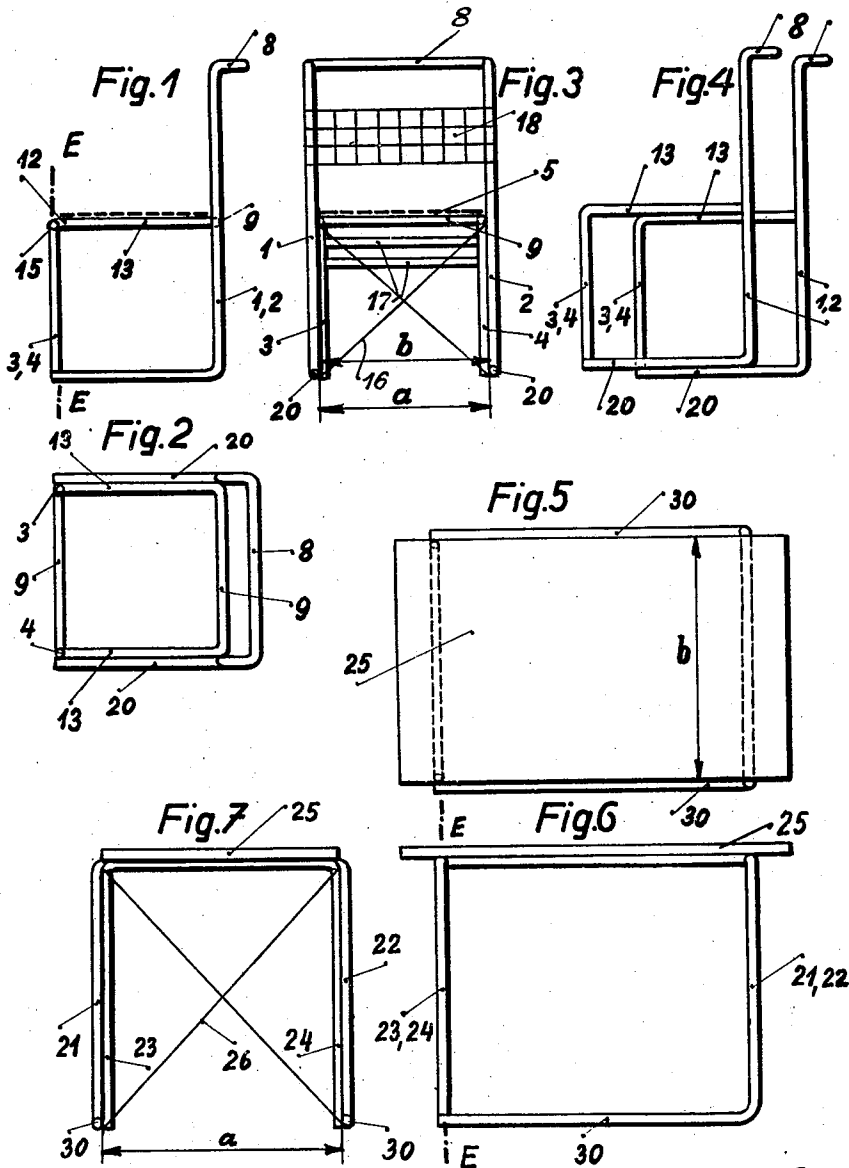

BRUNO POLLAK

Inventor

By *Otto Munt*
his Attorney

Jan. 29, 1935.

B. POLLAK

1,989,426

CHAIR, TABLE, AND THE LIKE ADAPTED FOR STACKING

Filed Jan. 30, 1930

4 Sheets-Sheet 2

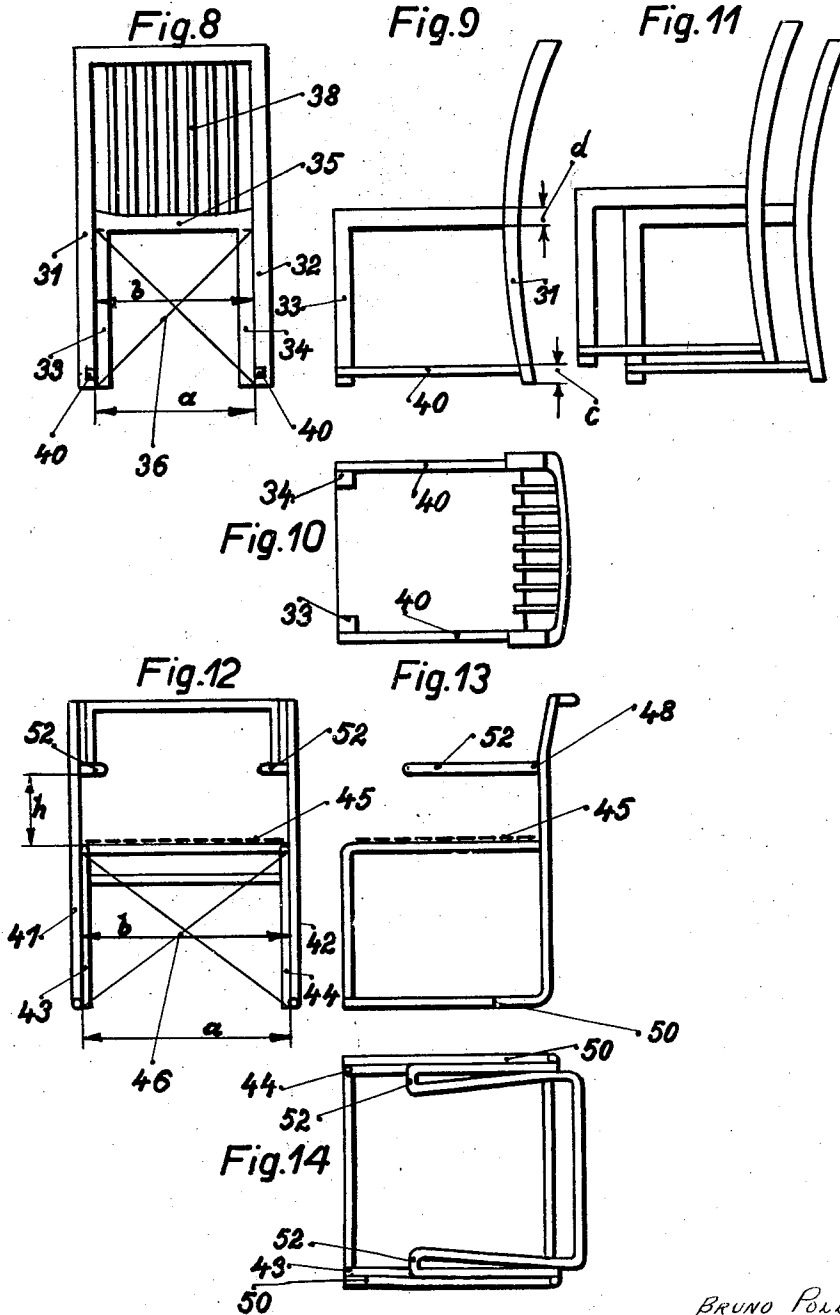

BRUNO POLLAK
Inventor

By the Attorney *Otto Mund*

Jan. 29, 1935.

B. POLLAK

1,989,426

CHAIR, TABLE, AND THE LIKE ADAPTED FOR STACKING

Filed Jan. 30, 1930

4 Sheets-Sheet 3

Fig.15

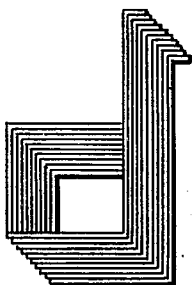

Fig.16

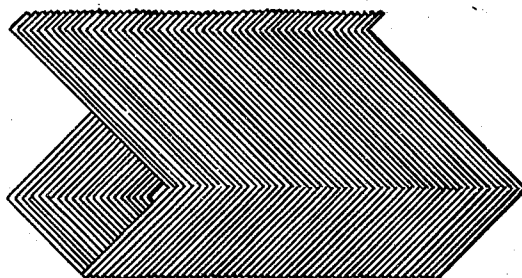

Fig.17

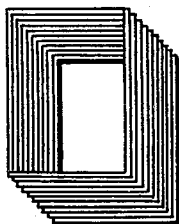

Fig.18

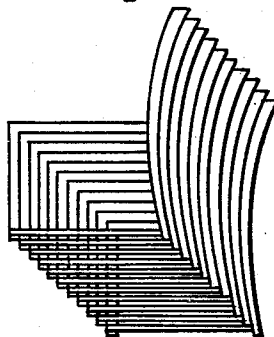
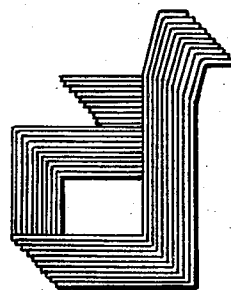

Fig.19



BRUNO POLLAK
Inventor

Otto Munt

By his Attorney.

Jan. 29, 1935.

B. POLLAK

1,989,426

CHAIR, TABLE, AND THE LIKE ADAPTED FOR STACKING

Filed Jan. 30, 1930

4 Sheets-Sheet 4

Fig. 20.

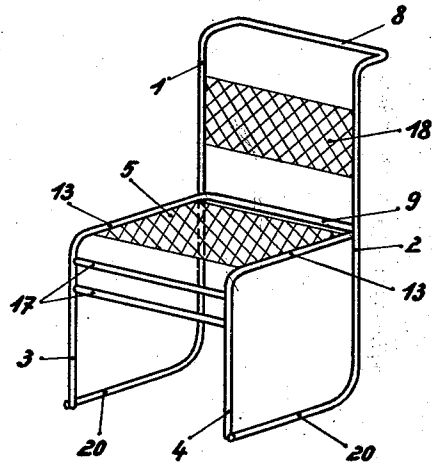
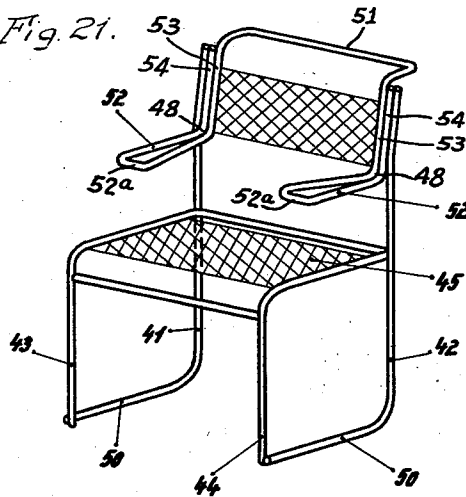

Fig. 21.



Bruno Pollak

INVENTOR

BY *[Signature]*
his ATTORNEY

UNITED STATES PATENT OFFICE

1,989,426

CHAIR, TABLE, AND THE LIKE ADAPTED FOR STACKING

Bruno Pollak, Vienna, Austria

Application January 30, 1930, Serial No. 424,498
In Austria February 1, 1929

5 Claims. (Cl. 155—2)

This invention relates to chairs, tables and the like, which are of simple and pleasing construction, may be nested or stacked in a simple manner, and when stacked occupy the smallest storage space that is practically possible. This object is achieved in accordance with the invention in that the article of furniture (chair, table or the like) is provided with a free opening circumscribed and limited by two of the legs and the seat or, in a table, by two of the legs and the table-top. This opening is such that its internal contour considered in elevation is equal to or greater than the external contour formed by the seat or table-top, respectively, and the remaining legs on any cross-section parallel to the plane in which the said free opening lies, so that the articles of furniture can also be stacked or rested by being slid upon or into each other in a horizontal direction.

Various forms of construction of the invention are shown in the accompanying drawings, in which—

Fig. 1 shows a chair in accordance with the invention, in side elevation;

Fig. 2 is a plan view of the same chair;

Fig. 3 shows the chair in front elevation;

Fig. 4 shows the manner of stacking two chairs of the type shown in Figs. 1-3, in side elevation;

Fig. 5 shows a table in accordance with the invention, in plan view;

Fig. 6 shows the same table in front elevation;

Fig. 7 is a side elevation of the same table;

Figs. 8, 9 and 10 show a further example of a form of construction for a chair made in accordance with the invention, in front elevation, side elevation, and plan elevation, respectively;

Fig. 11 shows the manner of stacking two chairs of the type shown in Figs. 8-10;

Figs. 12, 13 and 14 show a third example of a form of construction for a chair in accordance with the present invention, in front elevation, side elevation and plan view, respectively;

Figs. 15 and 16 show stacks of chairs of the type shown in Figs. 1 to 3;

Fig. 17 shows a stack of tables of the type shown in Figs. 5 to 7;

Fig. 18 shows a stack of chairs of the type shown in Figs. 8 to 10;

Fig. 19 shows a stack of chairs of the type shown in Figs. 12 to 14;

Fig. 20 is a perspective view of the form of the invention illustrated in Figs. 1, 2 and 3; and

Fig. 21 is a similar view of the invention shown in Figs. 12, 13 and 14.

In the chair shown in Figs. 1 to 3, consisting of

steel or iron tubes or the like, 1, 2, 3 and 4 are the legs of the chair, and 5 the seat. The legs 1 and 2 of the chair are formed by the shanks of a U-shaped bent tube 8. The shanks 1 and 2 are connected by a cross-bar 9 on a level with the seat 5. The legs 3 and 4 are formed by the one arm of each of the two L-shaped pieces 12, the other arms 13 of which are attached to the cross-bar 9. The two L-shaped pieces are connected together by a cross-bar 15. The quadrilateral formed by the parts 9, 13, 15, 13 serves for the attachment of the seating surface of the chair, which, in the example of a form of construction shown in the drawings, consists of stretched webbing 5. If necessary, the legs 3 and 4 can be further connected together by the additional cross-bars 17. The back of the chair is formed by the extension of the legs 1 and may, for example, likewise be provided with a filling of webbing 18.

In accordance with the present invention the inner distance of the two rear legs 1, 2 is equal to or greater than the outer distance of the front legs 3, 4. In the form of construction shown in the drawings the distance a between the two legs 1 and 2 is equal to the breadth b of the seat or the outer distance of the legs 3 and 4. In this manner chairs exactly alike in shape and size, as shown in Figs. 4, 15 and 16, are rendered capable of being stacked by being pushed or slid onto or into each other in a horizontal direction, in that the one chair is slid with its free opening 16, formed by the legs 1 and 2 and the cross-bar 9, over the other chair in the manner shown in Fig. 4. As Figs. 4, 15 and 16 likewise show, the seats of the stacked chairs rest directly upon each other, whereby a minimum of stacking space is required. This manner of construction of the chairs allows in particular of the stacking of the same in spaces with low head-room, or in other words, the total height of the storage space can be thoroughly exploited for stacking purposes.

In the form of construction shown in the drawings the legs 1, 3 and 2, 4 are further connected together by means of longitudinal members 20, 20 for the purpose of increasing the strength of the chair. These members are preferably disposed in the region of the ends of the legs and, in the example shown in the drawings, are formed integral with the legs 1 and 2. The stacked chairs rest with these longitudinal members 20 in contact with each other.

The legs of the table shown in Figs. 5 to 7 are of the same general construction as that of the chairs hereinbefore described. The new con-

struction renders it possible to stack tables which are similar in shape and size. Stacking is done, as shown in Fig. 17, by sliding one table onto or into another table in horizontal direction.

5 In the form of construction shown, the internal distance a between the two legs 21 and 22 is equal to or greater than the breadth b of the table top or the distance apart of the two legs 23 and 24, measured over all. The legs 21, 22, 23 and 24 are formed, in the example shown, by the shanks of two U-shaped bent tubes. The legs 21 and 23, as also 22 and 24, are connected together as to their ends by means of the longitudinal members 30; these latter, in the example 10 shown, are formed integral with the legs 21, 22. If the internal breadth of the hollow space under the table-top be sufficiently largely dimensioned, this space can be utilized to accommodate stacked chairs, whereby the storage space can be reduced to a minimum, especially in the case of sets of 20 tables and chairs.

In the example of a form of construction for a chair designed to be made in wood shown in Figs. 8 to 10; 31, 32, 33 and 34 are the legs and 35 the seat slab of the chair. The chair exhibits a free opening 36 bounded by the legs 31 and 32 and the seat slab 35 the contour and size of which is so determined that the chairs, while being entirely similar as to shape and size, are capable of being pushed or slid onto or into each other, in the manner shown in Fig. 11. In the form of construction shown, the inner distance a between the two rear legs 31 and 32 is equal to or greater than the breadth b of the seat slab 35, and the external distance b of the two front legs 33 and 34. The ends of the legs 31, 33 as also of the legs 32, 34 are connected together by means of longitudinal members, e. g., the rods 40. The extension of the legs 31 and 32 forms the framework of the back 38 of the chair. 40

The stacking of the chairs of the type shown in Figs. 8 to 10 is readily understandable from Figs. 11 and 18. It is advisable to arrange that the distance c between the upper surface of the longitudinal connecting pieces 40 and the ends of the legs is equal to the thickness d of the seat 45 slab 35, so that, as shown in Fig. 11, the chairs when stacked have their seats resting one upon the other, and the ends of their legs likewise resting upon the longitudinal connecting pieces 40. 50

The dimension c can, however, of course be greater or less than the thickness d of the seat slab 35. Only it will be clear that in the former case the available space for stacking will not be made use of to the best advantage, since in this case an intermediate space will be left between the seats of the chairs. 55

Referring to Figs. 12 to 14, inclusive, the chair comprises upright rear legs 41 and 42 and front legs 43 and 44 and a seat 45 of webbing. The legs are made principally of iron or steel tubing. The rear legs 41 and 42 each comprise a base portion 50 which is an integral part of the leg and which is bent forward at substantially right angles thereto to rest upon the floor and to be attached at its forward end to the lower end of the front leg at the outer side thereof. The upper ends of the rear legs 41 and 42 are connected or are integral with the ends of a back rest 51, which is a substantially inverted U-shaped member, the arms of which are disposed inside the legs 41 and 42 and at their lower ends are integral with the inner ends of arm rests 52. The rests are reversely bent lengths of tubing with upright inner ends disposed up- 75

right and intermediate the legs 41 and 42 and the lower ends of the back member 51. The rests are further disposed parallel with and spaced substantially above the seat 45 and the lateral arms of the front legs 43 and 44. 5

Between the upper ends of the leg members 41, 42 a deformed U-shaped back rest member 51 (Figs. 12, 13, 14) is disposed, the closed end 51 of which (Figs. 13 and 14) is bent backwardly to form a connection piece for the upper ends of the extending portion of the legs 41, 42 and the shanks of said U-shaped member being bent so that they form the arm support 52 which is perpendicular with respect to the leg members 41 and 42. 10 15

As shown in Fig. 21, the arm rests 52, at their forward ends 52a, are broadened and the bight 51 of the U-shaped back rest is bent as shown and is affixed to the back legs 41 and 42 by welding the shank portions 54 thereto. 20

On account of the arrangement of the arm 52 the chairs last described can only be stacked to the extent of the height h (Fig. 19). Since, however, the chairs come to rest with their seats one upon the other the stacking of a fair number of chairs is nevertheless vouched for. 25

The articles of furniture shown in the drawings naturally represent but a few of the many possible forms of construction embodying the invention. The articles of furniture and their details are susceptible of alteration within the scope of the described invention. 30

I claim:—

1. An article of furniture constructed of similar units adapted to be nested one within the other, each unit comprising a pair of front legs, a pair of rear legs and a rectangular plate horizontally supported thereon, the inner distance of the rear legs corresponding to the outer distance of the front legs and the width of said plate, and a connecting piece extending between corresponding legs of each pair and being disposed at the lower ends of the legs, one end of each piece overlapping the outer side of a leg of the second pair and being disposed in the plane of a leg of the first pair, whereby the plate of one chair abuts the plate of the preceding chair, when nested, and whereby the legs of each superimposed chair rest upon the connecting pieces of the preceding chair. 35 40 45 50

2. In a chair of the character described, the combination of a pair of L-shaped members forming the back and the bottom rungs, a second pair of inverted L-shaped members forming the front legs and the seat support attached at one of their ends to the inside of one pair of ends of the first L-shaped members and at their other ends to the inner sides of the back forming arms of the first L-shaped members at a point substantially midway of the length thereof, and means connecting the upper ends of the L-shaped members which form the back. 55 60

3. In a chair of the character described, the combination of a pair of L-shaped members forming the back and the bottom rungs, a second pair of inverted L-shaped members forming the front legs and the seat support attached at one of their ends to the inside of one pair of ends of the first L-shaped members and at their other ends to the inner sides of the back forming arms of the first L-shaped members at a point substantially midway of the length thereof. 65 70

4. A chair as claimed in claim 2, in which the means connecting the upper ends of the L-shaped 75

members comprises a U-shaped member having the mid portion of its arms attached to and disposed parallel to the upper ends of the L-shaped members forming the back, the closed end of the U-shaped member being uppermost and bent at an angle to form a rest, the free ends of the arms being bent forwardly to overlie the seat and form arm rests.

5. A chair, as claimed in claim 2, in which the said L-shaped members forming the back are bent outwardly at a point adjacent their upper ends and at right angles with respect to the back forming members, and a part joining said outwardly bent portions.

BRUNO POLLAK.