



US00D740959S

(12) **United States Design Patent**
Chen

(10) **Patent No.:** **US D740,959 S**

(45) **Date of Patent:** **** Oct. 13, 2015**

(54) **HUMAN BODY ENERGY ANALYSIS DEVICE SET**

(71) Applicant: **joy's International Cosmetics Pty Ltd,**
Thomastown, Victoria (AU)

(72) Inventor: **Tzu-Li Chen,** Thomastown (AU)

(73) Assignee: **joy's International Cosmetics Pty Ltd,**
Thomastown, Victoria (AU)

(**) Term: **14 Years**

(21) Appl. No.: **29/468,531**

(22) Filed: **Oct. 1, 2013**

(51) **LOC (10) Cl.** **24-00**

(52) **U.S. Cl.**
USPC **D24/231**

(58) **Field of Classification Search**
USPC D24/231, 107, 186, 216, 169, 200, 223;
356/446; 600/547, 479, 311, 493, 504,
600/436, 344, 323; 606/99

See application file for complete search history.

(56) **References Cited**

U.S. PATENT DOCUMENTS

4,014,323	A	*	3/1977	Gilmer et al.	600/547
4,121,574	A	*	10/1978	Lester	600/479
4,201,222	A	*	5/1980	Haase	600/311
4,320,767	A	*	3/1982	Villa-Real	600/493
4,569,355	A	*	2/1986	Bitterly	600/504
4,632,123	A	*	12/1986	Govaert et al.	600/436
4,685,464	A	*	8/1987	Goldberger et al.	600/344
4,791,461	A	*	12/1988	Kishimoto et al.	356/446
4,981,786	A	*	1/1991	Dafforn et al.	435/7.92
5,069,214	A	*	12/1991	Samaras et al.	600/323
5,318,570	A	*	6/1994	Hood et al.	606/99
D405,174	S	*	2/1999	Rogler	D24/107
D459,811	S	*	7/2002	Maus et al.	D24/169

(Continued)

Primary Examiner — Holly Baynham

Assistant Examiner — Rhea Shields

(74) Attorney, Agent, or Firm — patenttm.us

(57) **CLAIM**

The ornamental design for a human body energy analysis device set, as shown and described.

DESCRIPTION

FIG. 1 is an exploded perspective view of a human body energy analysis device set showing my new design; FIG. 2 is a perspective view of a base of the human body energy analysis device set; FIG. 3 is a front view thereof; FIG. 4 is a rear view thereof; FIG. 5 is a left side view thereof; FIG. 6 is a right side view thereof; FIG. 7 is a top view thereof; FIG. 8 is a bottom view thereof; FIG. 9 is another perspective view thereof; FIG. 10 is a perspective view of a detecting bar of the human body energy analysis device set; FIG. 11 is a front view thereof; FIG. 12 is a rear view thereof; FIG. 13 is a left side view thereof; FIG. 14 is a right side view thereof; FIG. 15 is a top view thereof; FIG. 16 is a bottom view thereof; FIG. 17 is another perspective view thereof; FIG. 18 is a perspective view of a detecting clamp of the human body energy analysis device set; FIG. 19 is a front view thereof; FIG. 20 is a rear view thereof; FIG. 21 is a left side view thereof; FIG. 22 is a right side view thereof; FIG. 23 is a top view the detecting clamp thereof; FIG. 24 is a bottom view thereof; FIG. 25 is another perspective view thereof; and, FIG. 26 is a perspective view thereof showing that the base, the detecting bar and the detecting clamp are connected through cables.

In the drawings, the broken lines depict unclaimed subject matter only and form no part of the claimed design.

1 Claim, 18 Drawing Sheets

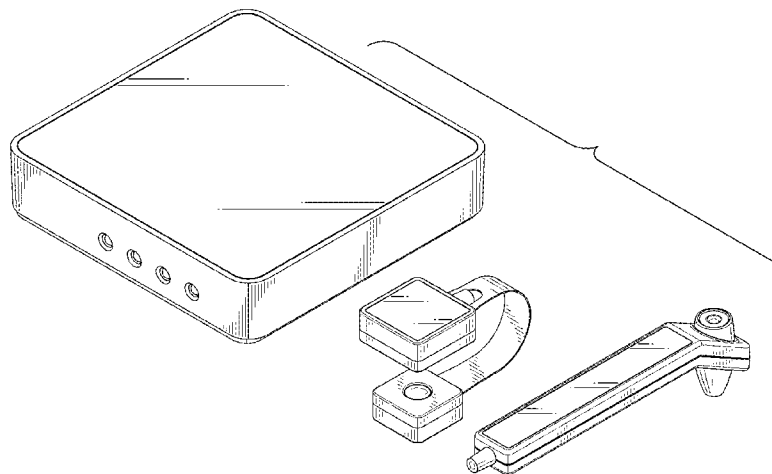

US D740,959 S

Page 2

(56)

References Cited

U.S. PATENT DOCUMENTS

D612,503 S * 3/2010 Johnston et al. D24/186
D627,476 S * 11/2010 Gaw et al. D24/186
D684,270 S * 6/2013 Chang et al. D24/216

D698,443 S * 1/2014 Prais et al. D24/169
D699,359 S * 2/2014 Lindekugel et al. D24/186
D706,435 S * 6/2014 Weng D24/200
D716,469 S * 10/2014 Muraoka et al. D24/216

* cited by examiner

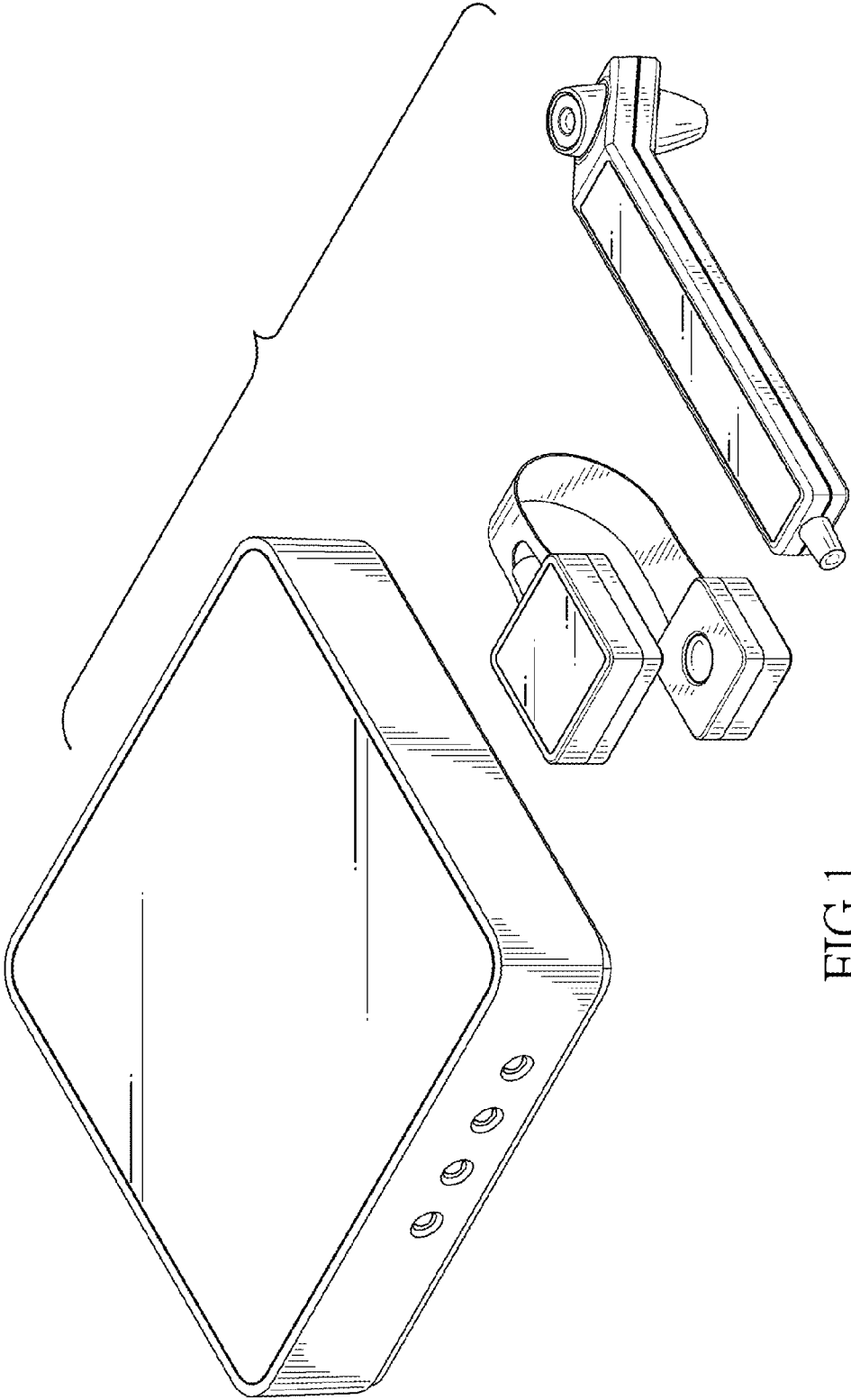

FIG.1

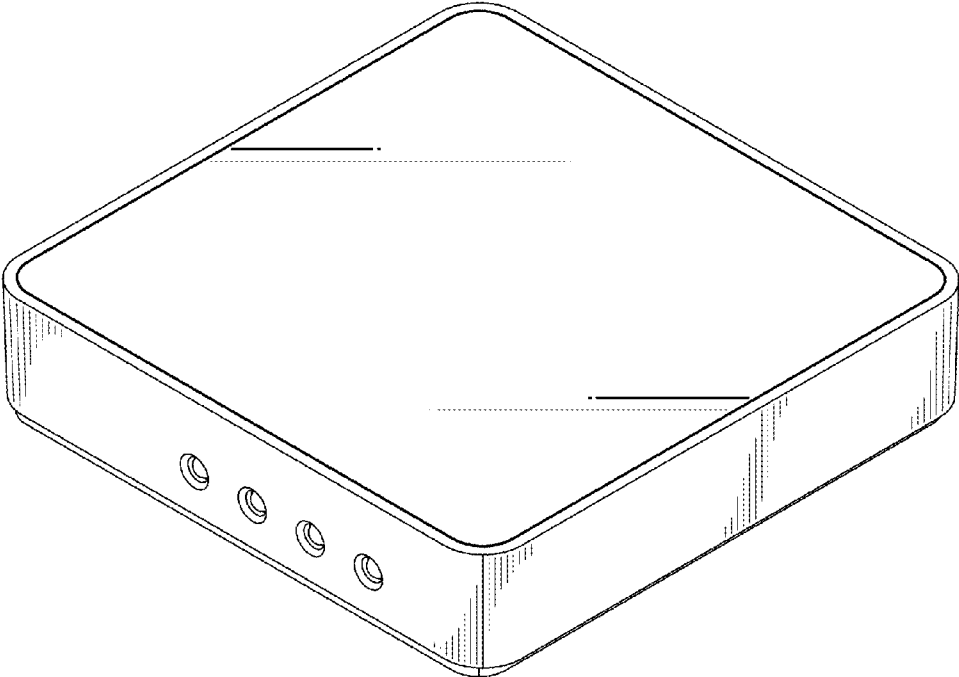

FIG.2

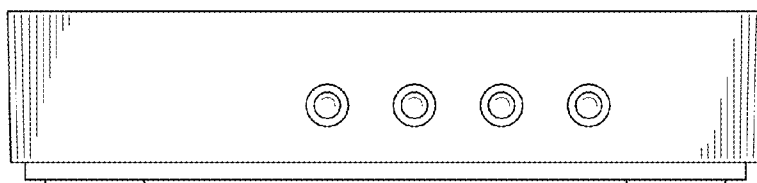

FIG.3

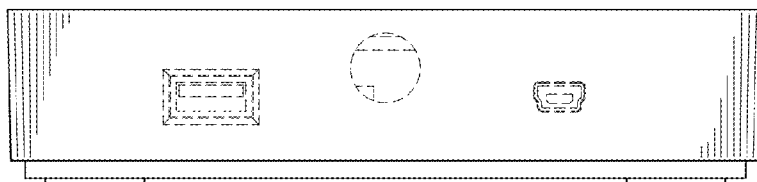

FIG.4

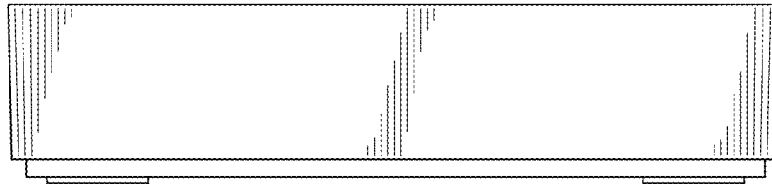

FIG.5

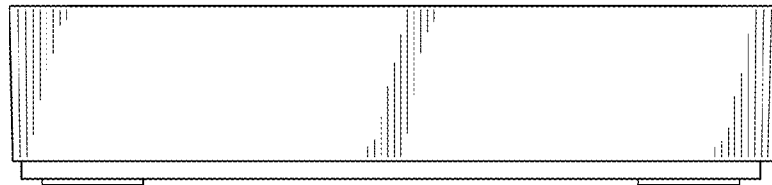

FIG.6

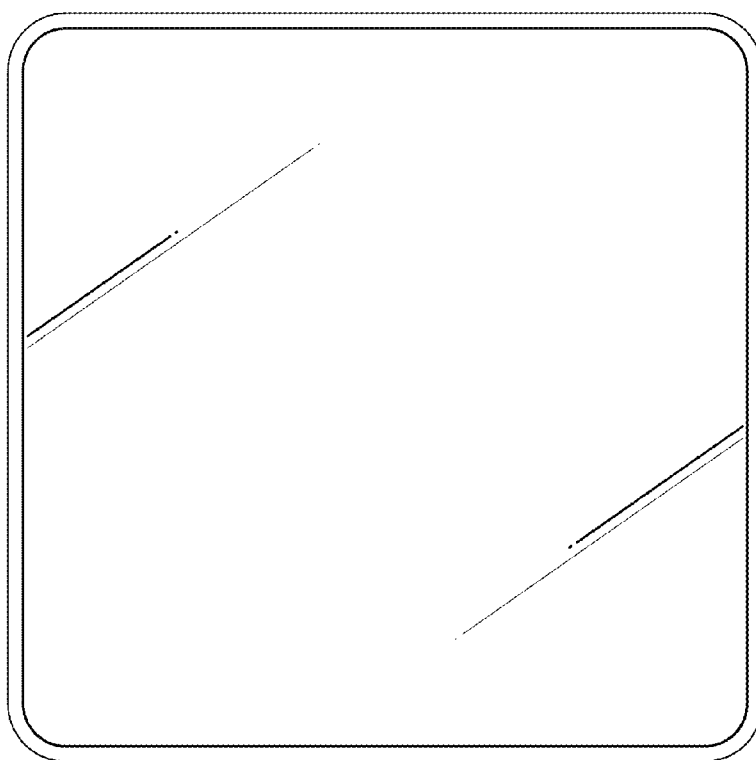

FIG.7

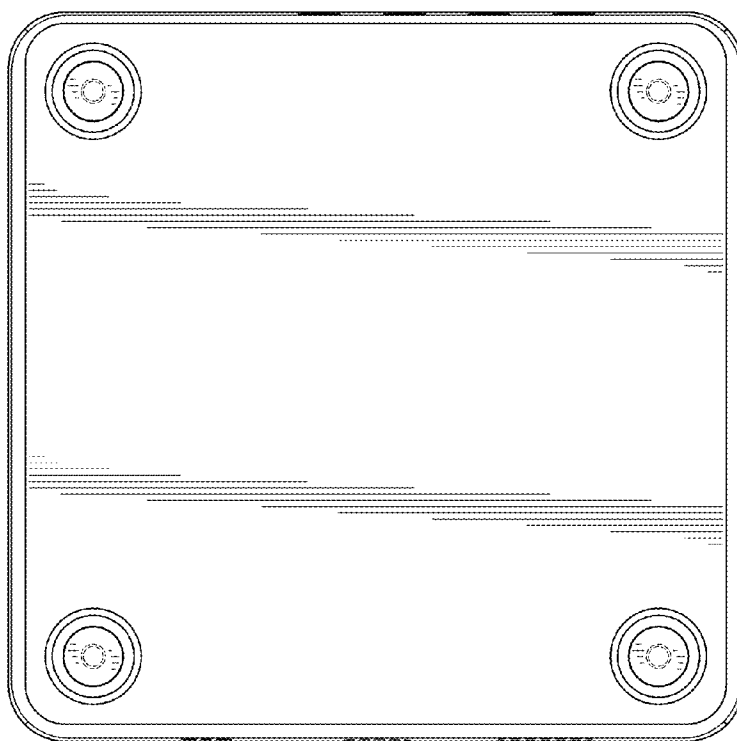

FIG.8

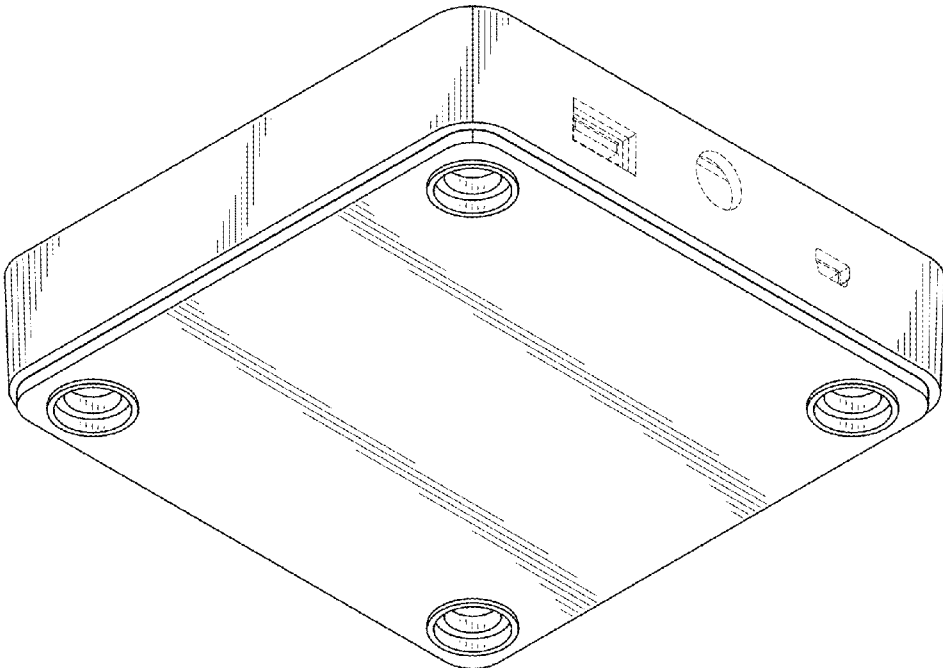

FIG.9

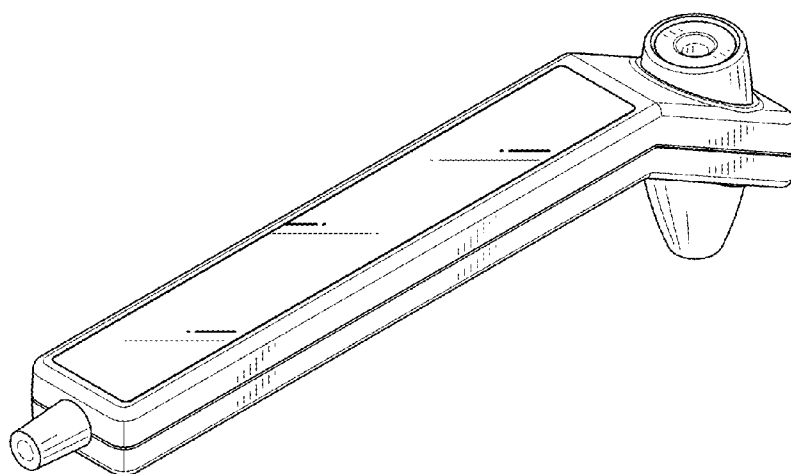

FIG.10

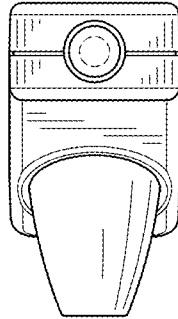

FIG.11

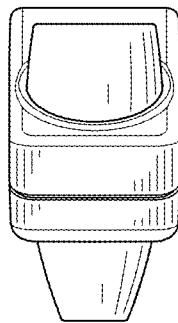

FIG.12

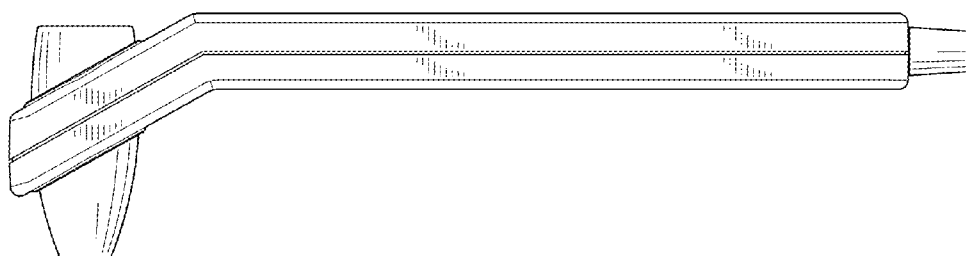

FIG. 13

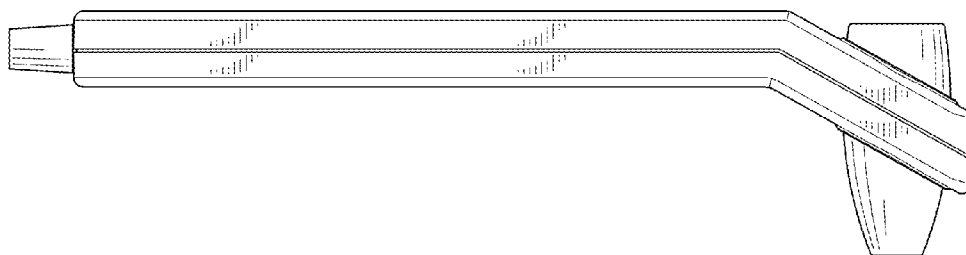

FIG. 14

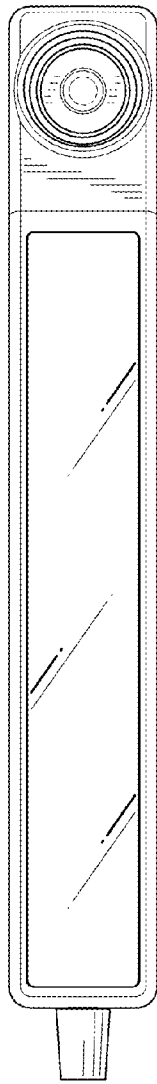

FIG. 15

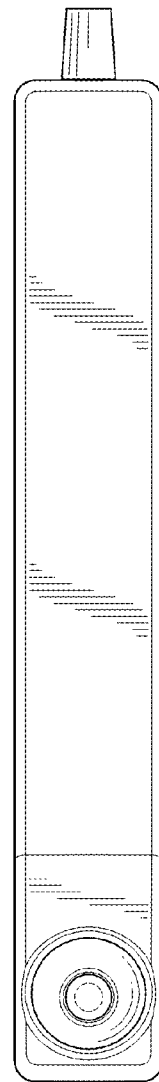

FIG. 16

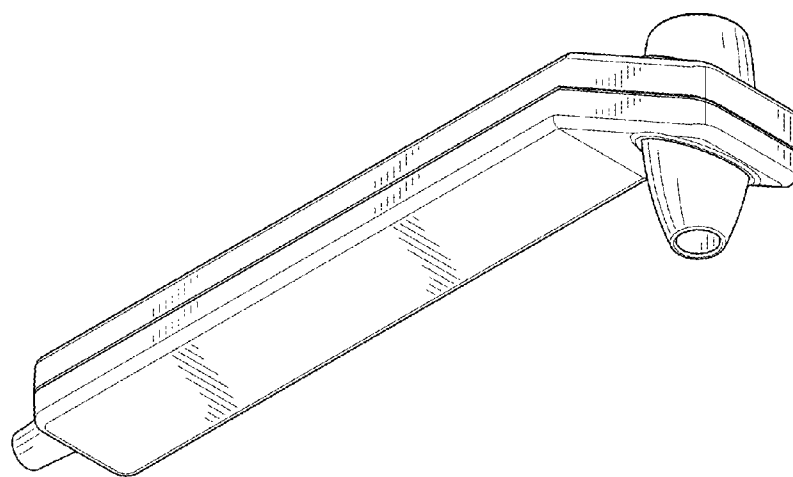

FIG.17

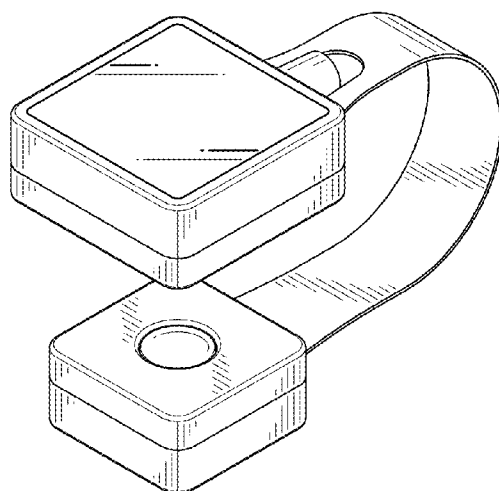

FIG.18

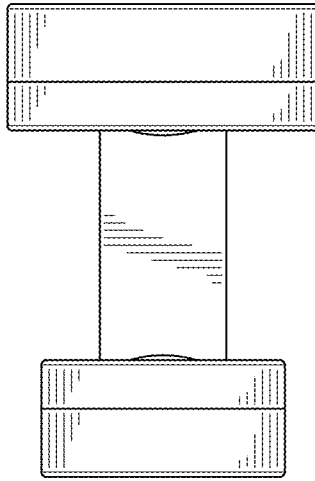

FIG. 19

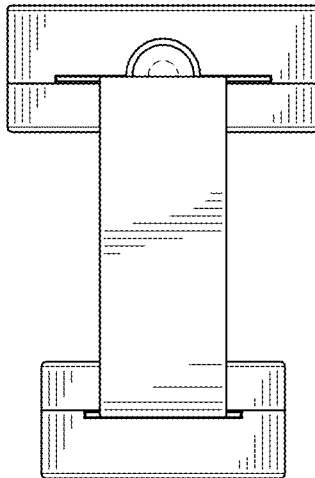

FIG. 20

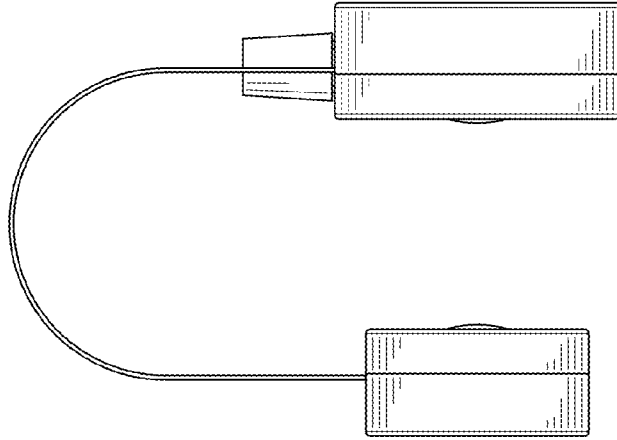

FIG. 21

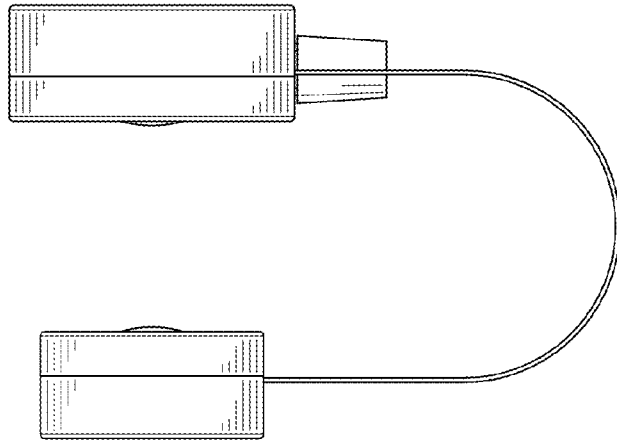

FIG. 22

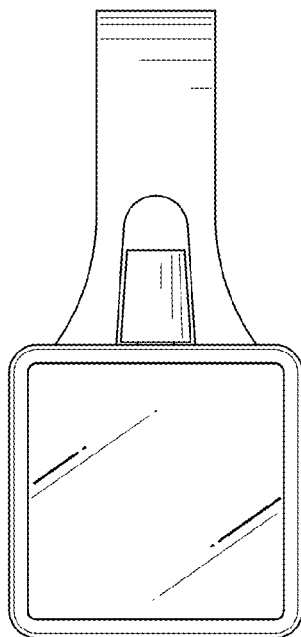

FIG. 23

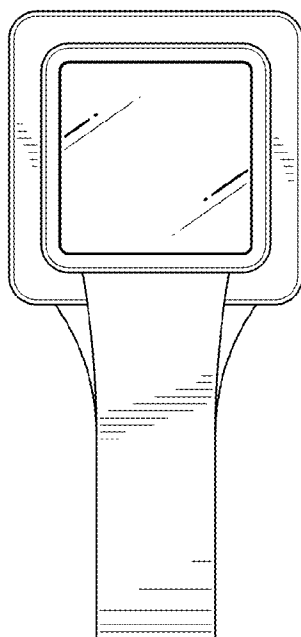

FIG. 24

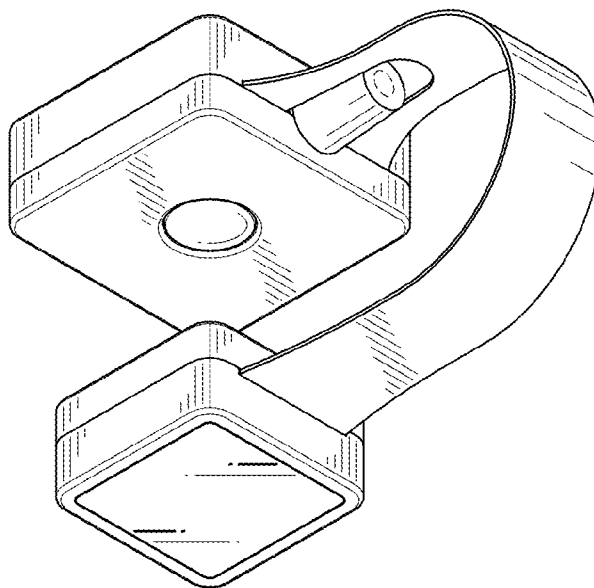

FIG. 25

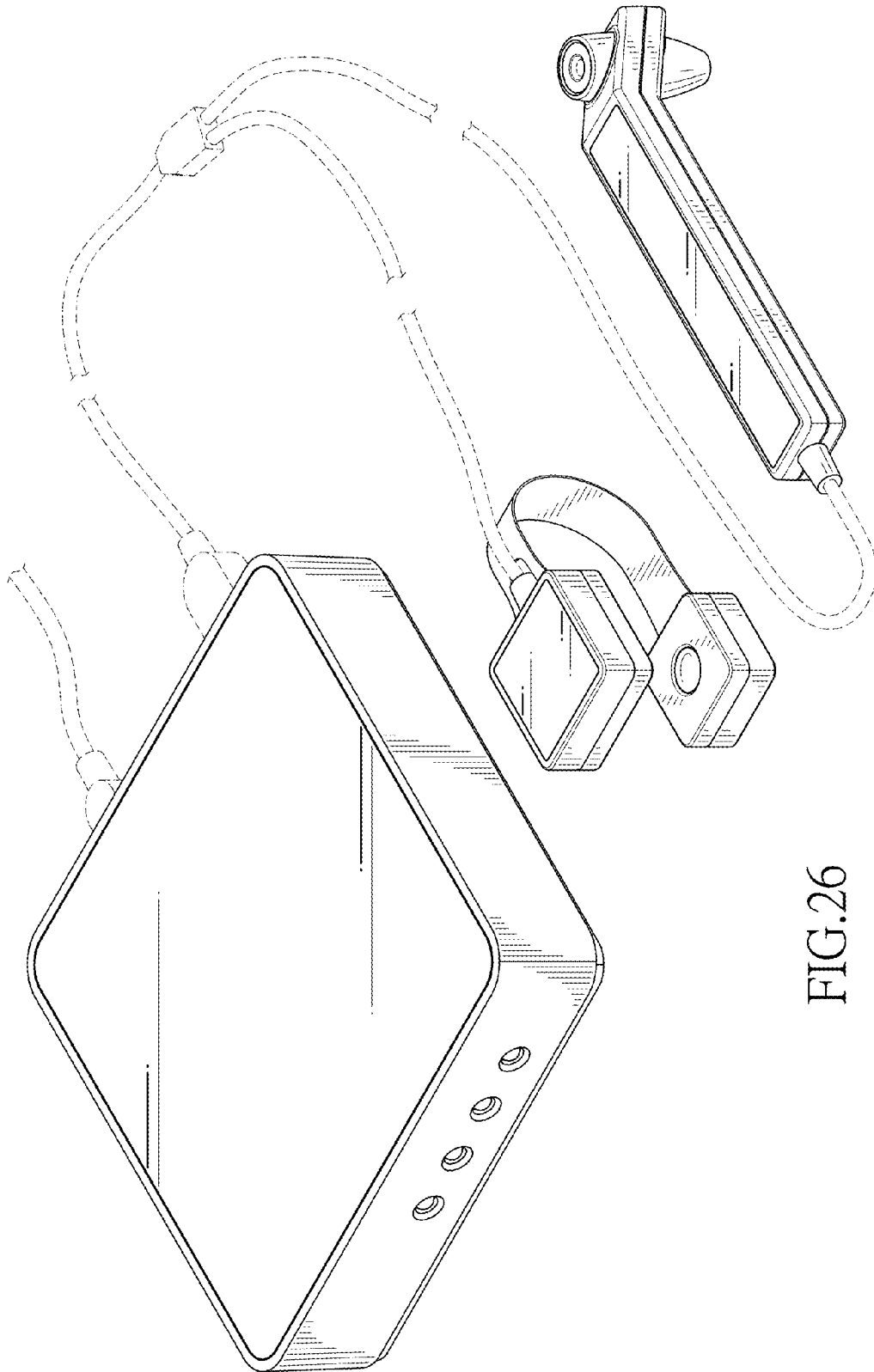

FIG.26