

HENRY BICKFORD.

Improvement in Mortising Machines.

119,007.

Patented Sep. 19, 1871.

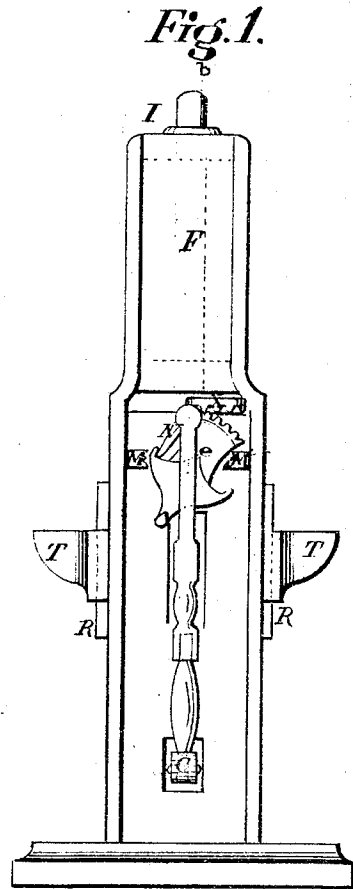
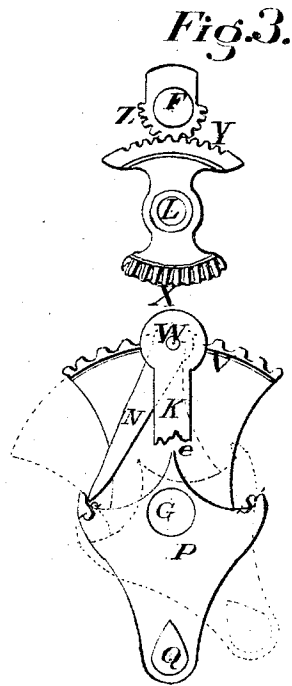
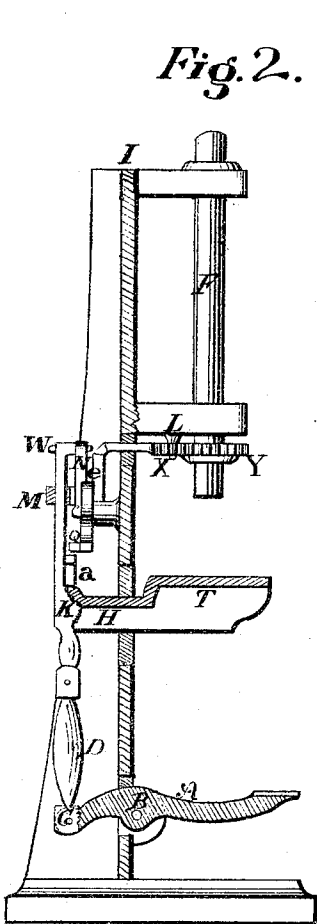

*Witnesses*

*P. M. Shuey  
C. G. Hale*

*Inventor.*

*Henry Bickford  
per Fisher & Fisher  
his attys.*

# UNITED STATES PATENT OFFICE.

HENRY BICKFORD, OF CINCINNATI, OHIO, ASSIGNOR TO J. A. FAY & CO., OF  
SAME PLACE.

## IMPROVEMENT IN MORTISING-MACHINES.

Specification forming part of Letters Patent No. 119,007, dated September 19, 1871.

*To all whom it may concern:*

Be it known that I, HENRY BICKFORD, of the city of Cincinnati, in the county of Hamilton and State of Ohio, have invented certain new and useful Improvements in Mortising-Machines, of which the following is a specification:

My invention relates to a device whereby, in conjunction with the weight of a movable operating table, the mortising-chisel is reversed, thus utilizing the weight of the table and avoiding the introduction of extra power.

In the accompanying drawing, making part of this specification, Figure I is a rear elevation of a mortising-machine to which my device is applied. Fig. II is a vertical central section of the same. Fig. III is a plan of the gear at the line *b b* of Fig. I.

I is the upright frame of the mortising-machine. A treadle, A, projecting forward from the frame, is pivoted in said frame at B, and, from the pivot extending through and beyond the rear of the frame, has its rear end pivoted at C to a short upright connecting-rod, D. The upper end of this connecting-rod is pivoted to the lower end of an upright shaft, K. The latter, near its upper end, slides vertically in a guide-way, M. The operating-table T slides vertically upon guides R R, one of the latter being placed on each side of the frame and grasped by overlapping flanges. An arm, H, from the table passes through a slot in the frame and is attached to shaft K. To the front of the top of shaft K, and between it and the frame, is pivoted a hanging and swinging finger, N. Just below the finger is a heart-shaped lever, P, oscillating on a pivot, G. In the top of the lever, and separated by a point, *e*, are two recesses or notches, S S', into each of which the finger alternately strikes. From the bottom of this lever a point, Q, projects toward the shaft K and engages with a long projecting guard, *a*, on shaft K, whereby lever P is held firm during the ascent of the table. Attached to and extending above lever P is a quadrant, V, with beveled gear, engaging a horizontal quadrant, X, with beveled gear. Quadrant X is attached to second horizontal quadrant Y, with straight gear. This latter gears into a horizontal half-gear wheel, Z, in front of the frame. The shaft F, which holds the mortising-chisel, passes through gear-wheel Z and is reversed by it. The two quadrants X and Y, as

attached together, form a double quadrant, which oscillates on a pivot, L, placed nearly midway between X and Y. The relative size of the quadrant is such that when quadrant Y has presented all of its teeth successively to the gear Z the shaft F will have been turned half-way round. At each end of the gear of quadrant Y and at each end of the gear on pinion Z are blind-stops. These stops check in a safe manner the further engagement of the gear in their direction.

The wood to be mortised being laid upon table T, the operator, pressing down the treadle A, lifts shaft K, and with it table T. The latter, in rising, brings the wood against the mortising-chisel and cuts one end of the mortise. As the shaft K rises the finger N is carried above the point *e* of the lever P and directly over recess S. The guard *a* of shaft K holds firm the point Q, and with it lever P, and quadrants V X Y, and gear Z and shaft F, with chisel, from turning in one direction, while two of the blind-stops, one on Y and one on Z, prevent the chisel and the gear from turning in the other direction. Thus the chisel is held still while one end of the mortise is being cut. When this end has been cut the pressure upon the treadle is relieved and the treadle, with shaft K, descends. During this descent the guard *a* passes below the point Q and leaves the latter, with the lever P, free to turn. A moment after finger N strikes into the recess S and, with the aid of the weight of the table, turns the lever P in the opposite direction from what it occupied before. Lever P, in turning, moves quadrant V, which moves quadrants X and Y, which latter turns gear-wheel Z and thereby gives the shaft F a half revolution, thus reversing the chisel. At the same time the other recess S' has been brought under the finger when vertical. The table ascends again and the other end of the mortise is cut, the blind-stops and guard holding the chisel firm. Upon the next descent of the finger recess S' is turned away from the vertical, the chisel again reversed, and recess S brought under the finger. With each descent of the table the finger strikes the alternate recess and reverses the chisel.

What I claim as new is—

1. The pivoted heart-shaped lever P, with or without point Q, substantially as and for the purposes set forth.

2. The operating mechanism, consisting of chisel-shaft F, gears Z, Y, X, and V, lever P provided with the point Q, and shaft K provided with projection *a* and finger N, all operated by a treadle and connecting-rod, substantially as and for the purposes set forth.

3. In combination with finger N, the pivoted lever P with or without point Q, and gear V, substantially as and for the purposes mentioned.

4. In combination with the mechanism specified in the third claim, the operating-table, substantially as and for the purposes set forth.

5. The gears Z and Y, when provided with blind-stops, for the purpose specified.

HENRY BICKFORD.

Witnesses:

W. H. DOANE,  
IRVING SPENCER.

(125.)