



(51) International Patent Classification:
B65D 81/32 (2006.01)

(21) International Application Number:
PCT/EP2018/057205

(22) International Filing Date:
21 March 2018 (21.03.2018)

(25) Filing Language: English

(26) Publication Language: English

(30) Priority Data:
PA 2017 70202 21 March 2017 (21.03.2017) DK

(71) Applicant: RPC SUPERFOS A/S [DK/DK]; Spotorno Al-
lé 8, 2630 Taastrup (DK).

(72) Inventor: FREDERIKSEN, Lars Skjold; Anders Ras-
mussensvej 37, Kirke Hyllinge, 4070 Ejby (DK).

(74) Agent: GUARDIAN IP CONSULTING I/S; Diplomvej,
Building 381, 2800 Kgs. Lyngby (DK).

(81) Designated States (unless otherwise indicated, for every
kind of national protection available): AE, AG, AL, AM,
AO, AT, AU, AZ, BA, BB, BG, BH, BN, BR, BW, BY, BZ,
CA, CH, CL, CN, CO, CR, CU, CZ, DE, DJ, DK, DM, DO,
DZ, EC, EE, EG, ES, FI, GB, GD, GE, GH, GM, GT, HN,
HR, HU, ID, IL, IN, IR, IS, JO, JP, KE, KG, KH, KN, KP,
KR, KW, KZ, LA, LC, LK, LR, LS, LU, LY, MA, MD, ME,
MG, MK, MN, MW, MX, MY, MZ, NA, NG, NI, NO, NZ,
OM, PA, PE, PG, PH, PL, PT, QA, RO, RS, RU, RW, SA,
SC, SD, SE, SG, SK, SL, SM, ST, SV, SY, TH, TJ, TM, TN,
TR, TT, TZ, UA, UG, US, UZ, VC, VN, ZA, ZM, ZW.

(84) Designated States (unless otherwise indicated, for every
kind of regional protection available): ARIPO (BW, GH,
GM, KE, LR, LS, MW, MZ, NA, RW, SD, SL, ST, SZ, TZ,
UG, ZM, ZW), Eurasian (AM, AZ, BY, KG, KZ, RU, TJ,
TM), European (AL, AT, BE, BG, CH, CY, CZ, DE, DK,
EE, ES, FI, FR, GB, GR, HR, HU, IE, IS, IT, LT, LU, LV,
MC, MK, MT, NL, NO, PL, PT, RO, RS, SE, SI, SK, SM,
TR), OAPI (BF, BJ, CF, CG, CI, CM, GA, GN, GQ, GW,
KM, ML, MR, NE, SN, TD, TG).

(54) Title: CONTAINER COMPRISING RUPTURABLE POUCH ARRANGED INSIDE CONTAINER

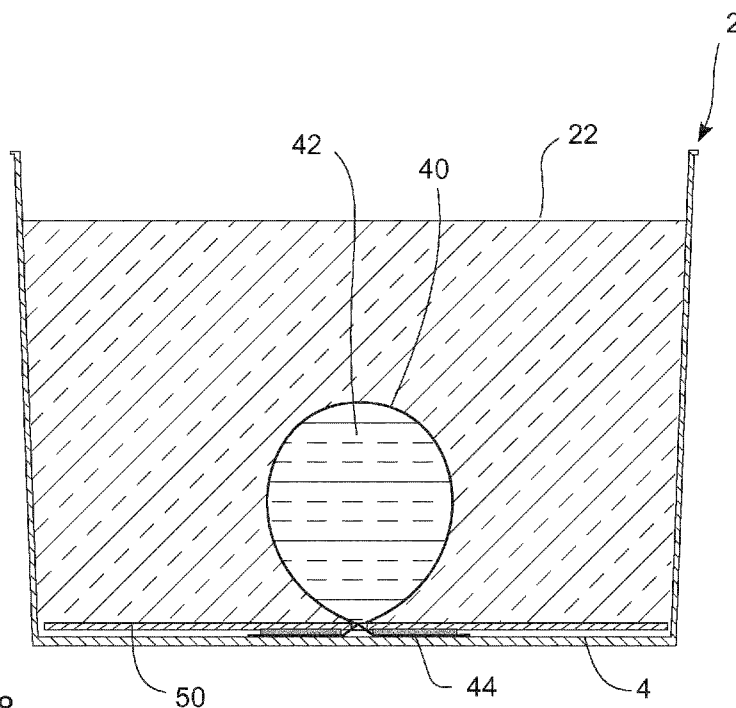

Fig. 8

(57) Abstract: Container comprising a bottom portion and a side wall portion extending upwardly from the bottom portion, said container being at least partially filled with a first material, said container further comprising a pouch filled with a second material, said pouch being arranged inside the container. Said pouch is arranged to be fastened to the bottom portion of the container such that at least a portion of the first material is arranged above the pouch and in that the pouch is rupturable. In this way, a container is provided whereby a second material can be mixed with a first material in a safe manner with a lowered risk of splashing.



Published:

- *with international search report (Art. 21(3))*
- *before the expiration of the time limit for amending the claims and to be republished in the event of receipt of amendments (Rule 48.2(h))*

Container comprising rupturable pouch arranged inside container

The current invention relates to a container comprising a bottom portion and a side wall portion extending upwardly from the bottom portion, said container being at least partially filled with a first material, said container
5 further comprising a pouch filled with a second material, said pouch being arranged inside the container.

Description of related art

10

Containers which allow mixing of two separate materials prior to use are well known in the art. Most containers known in the art provide a main container filled with a first material and a small pouch filled with the second material. The pouch is typically attached to the main container during transport. Prior
15 to use, the pouch is opened and the second material is added to and mixed with the first material.

In certain cases, the pouch is arranged inside the main container and a mechanism is provided in the lid or in the side wall of the container to open
20 the pouch, thereby causing the first and second materials to mix together. Some examples are disclosed in: DE102010006271 A1, US3797646 A, US3043424 A, US2921718 A, US2819738 A, DE1071579 B, WO06118697 A2, WO13056800 A1, US4130198 A, US3874557, US4927012, EP2463212 and US2752036 A.

25

However, in the case where the second material is dangerous for human touch, there is a risk when opening the pouch or when handling the pouch that the user gets the second material on his or her skin. Likewise, some of the solutions provided for in the prior art require complicated containers
30 and/or mechanisms arranged in the lid/container and which can both weaken and/or increase the cost of the containers.

Summary of the invention

It is therefore a first aspect of the current invention to provide a container as
5 mentioned in the introductory paragraph which allows mixing of two
components prior to use in a safe manner.

A second aspect of the current invention is to provide a container comprising
10 a pouch filled with a second material in a simple and low cost manner.

A third aspect of the current invention is to provide a container where the
second material is easily mixed with the first material.

These aspects are solved at least in part by a container as mentioned in the
15 introductory paragraph where the pouch is furthermore arranged to be
fastened to the bottom portion of the container such that at least a portion of
the first material is arranged above the pouch and in that the pouch is
rupturable. By arranging the pouch at the bottom of the container and
fastening it to the bottom portion, the pouch and the contents of the pouch
20 are completely covered by the first material. In order to release the contents
of the pouch, an implement can be inserted into the first material which
pierces the pouch or causes the pouch to rupture/burst when force is applied.
When the pouch ruptures, the second material is released into the first
material at the bottom of the container. As the first material is stirred, the
25 second material is quickly mixed with the first material. By the time the
second material reaches the surface of the first material, the risk for
splashing is much reduced.

It should be noted that the phrase "fastened to the bottom portion" should be
30 understood in that the pouch is arranged in a fixed position and at the bottom
portion of the container. The pouch could either be fastened directly to a

surface of the bottom portion, or it could be held in place against a surface of the bottom portion via an intermediate holding element. However, in both cases, the pouch is held in place against the bottom portion of the container. This is in contrast to the prior art solutions where a pouch is held and fastened to the lid or to the side wall of the container. It should also be noted that the term "fastened to" should be understood in that the pouch is held against the bottom portion in a fixed position so the pouch doesn't freely move around the container and such that it is easy to find the pouch and cause it to rupture. However, it does not necessarily mean that the pouch is permanently attached to the bottom portion.

It should also be noted that the phrase "at least a portion of the first material is arranged above the pouch" should be understood that there is an offset between the upper surface of the first material and the uppermost surface of the pouch. In this way, when the pouch is ruptured, the second material is not directly accessible from the upper surface of the first material. The second material first has to travel through the first material to reach the upper surface of the first material. In one embodiment, it could be that there was no direct connection between the pouch and the upper surface of the first material. In another embodiment, it could be that the container was arranged such that in order to rupture the pouch, it was necessary to insert an implement into the first material to agitate the first material and/or apply pressure directly to the pouch. In one embodiment, it could be said that the pouch was completely surrounded by the first material, or it could be said that the pouch was completely embedded in the first material.

In one embodiment, the pouch has an outer surface and the pouch can be arranged offset from the side wall portion such that some of the first material is arranged between the outer surface of the pouch and an inner surface of the side wall portion. In this way, the pouch is spaced from the side wall and when the second material is released, it is not in direct contact with the

sidewall. If the second material was in direct contact with the side wall, it could run up along the side wall and splash out the top of the container. In one embodiment, the minimum distance between the outer surface of the pouch and the inner surface of the sidewall portion could be defined to be
5 greater than 5mm, 10mm, 15mm or 20mm.

In one embodiment, the pouch could comprise a flexible material. In one embodiment, the pouch could comprise a foil or sheet like material. In one embodiment the pouch could be arranged as a welded plastic bag filled with
10 the second material.

In one embodiment, the pouch could comprise a weakened portion which is arranged to rupture and release the second material from the pouch when a predetermined pressure/force is applied to the pouch.
15

In one embodiment, the pouch could be fastened to the bottom portion via an adhesive or via a weld. In one embodiment, the weld and/or adhesive could be applied directly between the pouch and a surface of the bottom portion of the container. However, in another embodiment, the container could further
20 comprise an intermediate holding element arranged to fasten the pouch to the bottom portion of the container and/or to hold the pouch in place near the bottom portion of the container.

In one embodiment, the intermediate holding element is a planar element
25 having a planar surface area essentially corresponding to the surface area of an inside surface of the bottom portion. In one embodiment, the outer periphery of the intermediate holding element is smaller than the inner periphery of the bottom portion of the container such that the intermediate holding element can be arranged inside the container. In one embodiment,
30 the intermediate holding element is arranged to correspond to the bottom portion of the container such that the intermediate holding element is like a

false bottom. In one embodiment, the surface area of the intermediate holding element is large enough such that the weight of the first material on the intermediate holding element holds the intermediate holding element in place against the bottom portion of the container.

5

In one embodiment, the pouch can be fastened to an upper and/or lower surface of the intermediate holding element via a weld or via an adhesive. If fastened to a lower surface, a slot or opening could be formed in the intermediate holding element and a portion of the pouch could be arranged to pass through the slot or opening.

10

In another embodiment, instead of a weld or adhesive, the pouch could be fastened to the intermediate holding element via a mechanical gripping mechanism. In one embodiment, the mechanical gripping mechanism could comprise a snap locking mechanism.

15

In one embodiment, the second material is a liquid. In one embodiment, the second material is a material which is harmful to skin contact, for example the second material could be a caustic material. In one embodiment, the first material is a material for forming a surface covering of a building, for example a mortar material, a filler material, a paint like material, etc. In one embodiment, the container is a plastic injection moulded container. In one embodiment, the container is a poly propylene container and the pouch is made from a polyethylene material.

20

25

It should be emphasized that the term "comprises/comprising/comprised of" when used in this specification is taken to specify the presence of stated features, integers, steps or components but does not preclude the presence or addition of one or more other features, integers, steps, components or groups thereof. For example, in the claims, it states that the container comprises a pouch filled with a second material. However, this should be

30

understood in that the container comprises at least one pouch and solutions comprising two or more pouches would also be covered.

Brief description of the drawings

5

In the following, the invention will be described in greater detail with reference to embodiments shown by the enclosed figures. It should be emphasized that the embodiments shown are used for example purposes only and should not be used to limit the scope of the invention.

10

Figure 1 shows a schematic side cross section view of a first embodiment according to the invention prior to mixing.

15

Figure 2 shows a schematic side cross section view of the embodiment of figure 1 after mixing has occurred.

Figure 3 shows a schematic front view of one embodiment of a pouch for a container according to the invention.

20

Figure 4 shows a schematic side view of the pouch of figure 3.

Figure 5 shows a schematic side view of an intermediate holding element in the form of a false bottom plate for a container according to the invention.

25

Figure 6 schematically shows a step in the process of fastening the pouch of figures 3 and 4 to the false bottom plate of figure 5.

Figure 7 schematically shows the pouch and the false bottom plate being inserted into a container.

30

Figure 8 schematically shows the container of figure 7 filled with a first material.

Figure 9 shows a schematic cross sectional side view of another embodiment
5 of a container according to the invention.

Figure 10 shows a schematic cross sectional side view of another embodiment of a container according to the invention.

10 Figure 11 shows a schematic cross sectional side view of yet another embodiment of a container according to the invention.

Figure 12 shows a schematic side view of an embodiment of a pouch suitable for a container according to the invention.

15

Figures 13 and 14 show two views of a false bottom plate having a mechanical clip mechanism for holding a pouch.

Figure 15 shows the false bottom plate of figures 13 and 14 in a configuration
20 just after manufacture.

Figure 16 schematically shows how a pouch could be fastened to the false bottom plate of figures 13-15.

25 Detailed description of the embodiments

Figure 1 shows a container 2 comprising a bottom portion 4, a side wall portion 6 and an opening 8. The upper edge 10 of the side wall portion defines a rim 12 which encircles the opening 8. The bottom portion 4 has an
30 inside surface 14 and an exterior surface 16. Likewise, the side wall portion 6 also has an inside surface 18 and an exterior surface 20. The container 2 is

filled with a first material 22. From the figures, it can be seen that the area of the opening 8 is larger than the area of the inside surface 14 of the bottom portion 4. In this way, the containers are stackable one inside the other when they are empty. This type of container is well known in the art.

5

Containers of this kind are well known in the art and can be found in many shapes and sizes and can be used to hold many different types of materials. Likewise, the container itself can be made from many different types of materials. In many cases, the container is made from a plastic injection
10 moulded material, for example Poly Propylene. In other cases, the container could be made from a metal material. In many cases, the container can be a cylindrical container with a circular cross section. In other cases, the container has a more rectangular cross section. However, many shapes can be imagined.

15

According to the invention, a pouch 24 is arranged on the inside surface 14 of the bottom portion 4. The pouch in the current embodiment is made from a flexible plastic foil like material, similar to a plastic bag. The pouch can be made in many different ways. Suitable techniques for manufacturing suitable
20 pouches should be available in the art.

In the current embodiment, the pouch is filled with a liquid material 26. In this embodiment the liquid material is of a kind which is dangerous for human contact and it is therefore desired to prevent the second material from getting
25 into contact with the user. The pouch 24 is fastened to the inside surface 14 of the bottom portion 4 of the container via an adhesive 28.

Prior to use, it is desired to mix the first and second materials together. A stirrer 30 is therefore introduced into the container. The stirrer can be pressed into contact with the pouch thereby causing the pouch to rupture. Or
30 the stirrer can stir the first material which causes force to be applied to the

pouch which causes the pouch to rupture. Figure 2 shows how the pouch 24 has ruptured. Figure 2 also shows that even after rupturing, the material of the pouch itself remains fastened to the bottom portion of the container. Likewise, since the material of the pouch itself is flexible, the pouch itself should not prevent the user from accessing the contents of the container.

In the current embodiment, and in some of the other embodiments disclosed in this application, the pouch is arranged near the centre of the container and at the bottom of the container. In this way, the first material surrounds the pouch. In this case, there is first material 32 above the top surface of the pouch. Likewise, there is first material 34 between the sides of the pouch and the side wall portion of the container. Were the pouch arranged close to the side wall portion, then the second material could slide up along the side wall portion of the container and splash out the top of the container in a dangerous manner. By placing the pouch such that there is first material all around the pouch, there is less risk of splashing and simultaneously there is also a better mixing effect.

In one concrete and non-limiting embodiment, the container is a 10L plastic injection moulded bucket with a circular cross section filled with a mortar material used for exterior surface finishing in the construction industry. The second material inside the pouch comprises Natrium/Sodium hydroxide which is caustic and can cause injury to a user when it gets in contact with their skin.

25

In the embodiment shown in figures 1 and 2, the pouch 24 was fastened directly to the inside surface 14 of the bottom portion 4 of the container. However, in other embodiments, the pouch could be fastened to the bottom portion of the container via an intermediate holding element which is inserted into the container prior to filling the container with the first material. Some example embodiments are discussed in more detail below.

30

Figures 3 and 4 show another embodiment 40 of a pouch filled with a second material 42. The pouch is again made from a flexible plastic material in the form of a sheet or foil. In the figures, the pouch is shown having a curved shape, however, the pouch could also be formed with other shapes, for example, a rectangular shape. In one example, not shown, a plastic tubelike material, is welded shut at one end with a linear weld perpendicular to the extension of the tubular material. Second material can then be filled into the tube in the desired amount. The tube can then be welded shut, again with a linear weld. A closed and filled pouch is produced in this way in a simple manner. In the embodiment shown in the figures, two flaps 44 of excess material extend from the pouch and can be used to fasten the pouch to the bottom portion of the container.

Since welding or gluing the pouch to the inside surface of the bottom portion of the container can be complicated to implement in a production environment, the pouch can be fastened to a holding element 50 as shown in figures 5 and 6. The holding element 50 of the current embodiment is formed as a planar element having a cross section with a planar shape which matches the planar surface area of the inside surface of the bottom portion of the container. In this way, the holding element can be inserted into the container and it will assume a position at the bottom of the container. It could therefore be called a false bottom plate like element.

The holding element 50 has a slot 52 in the centre portion of the holding element. As shown in figure 6, the flaps 44 of the pouch 40 can be inserted through the slot and then folded up on the rear surface 54 of the holding element. An adhesive 56 applied on the rear surface 54 holds the flaps of the pouch in place. In this way, a strong connection is formed between the pouch and the holding element 50. The flaps 44 could also be welded to the rear surface of the holding element.

Once the pouch is securely fastened to the holding element, the pouch and holding element assembly can be inserted into the bottom of a container. This is shown in figure 7. In figure 8, first material is filled into the container thereby covering the pouch completely. Due to the weight of the first material, the holding element 50 is held in place, pressed against the inside surface of the bottom portion of the container. In this way, the pouch is likewise held fastened to the bottom portion of the container and located in the centre of the container.

10

Figure 9 shows another schematic embodiment of a container according to the current invention where a pouch 40 with flaps 44 is glued via an adhesive 56 to the inside surface 14 of the bottom portion 4 of the container 2. Instead of gluing, it would also be possible to weld the pouch to the container via the flaps.

15

Figure 10 shows another schematic embodiment. In this embodiment, a pouch 40 with a flap 44 is welded or glued via an adhesive 56 to a holding element 50 which is again shaped to fit into the bottom of the container. One advantage of using a holding element to hold the pouch, is that the pouch and the holding element could be chosen as one type of material while the container was chosen as another material. For example, the pouch could be chosen as a poly ethylene material which has good rupture properties and then it could be welded directly to a poly ethylene holding element. The container itself could be manufactured from a poly propylene material which has good robust properties for the actual container.

20

25

Figure 11 shows an embodiment, where the pouch 58 is formed as a flatter pouch which is welded or glued via an adhesive 56 to the holding element at at least two points via at least two flaps 59. By using a flatter pouch, the pouch could fit between two containers when stacked in an empty

30

configuration. In other words, the height of the pouch and holding element combination is less than the distance between the exterior surface 16 of the bottom portion of an upper stacked container and the inside surface 14 of the bottom portion of a lower stacked container.

5

Figure 12 shows one embodiment of a pouch 60 with a weakened area in the form of a number of lines of weakness 60 introduced into the material of the pouch. When pressure/force is applied to the pouch, the pouch will rupture along the lines of weakness.

10

Figures 13-16 illustrate another embodiment of a holding element 70. In this case, the holding element 70 is formed as a planar disc shaped element 70. Two slots 72 are provided in the disc into which flaps of the pouch can be inserted. Two bendable portions 73 are arranged in the disc on each side of the slots. The two bendable portions are provided with snap engagement means 74 which cooperate with corresponding snap engagement means 76 on the disc itself. In this embodiment the snap engagement means 74,76 are arranged as holes and plugs which fit into each other and engage each other. When the flaps 44 of the pouch 40 are inserted through the slots, the bendable portions are bent such that they sandwich the flaps between the disc and the bendable portions. This is shown in figure 16. When the snap engagement means are engaged, the flaps are held tightly in place and the pouch is therefore also held tightly in place against the holding element. It should be noted that figures 13 to 15 show the holding element from the bottom. In use, the bendable portions will bend downwardly as shown in figure 16.

25

It is to be noted that the figures and the above description have shown the example embodiments in a simple and schematic manner. Many of the specific mechanical details have not been shown since the person skilled in

30

the art should be familiar with these details and they would just unnecessarily complicate this description.

Claims

1. Container comprising a bottom portion and a side wall portion extending upwardly from the bottom portion, said container being at least partially filled with a first material, said container further comprising a pouch filled with a second material, said pouch being arranged inside the container, **characterized** in that said pouch is fastened to the bottom portion of the container such that at least a portion of the first material is arranged above the pouch and in that the pouch is rupturable.
2. Container according to claim 1, **characterized** in that the pouch has an outer surface and in that the pouch is arranged offset from the side wall portion such that some of the first material is arranged between the outer surface of the pouch and an inner surface of the side wall portion..
3. Container according to claims 1 or 2, **characterized** in that the pouch comprises a flexible material.
4. Container according to any one of claims 1 to 3, **characterized** in that the pouch comprises a weakened portion which is arranged to rupture and release the second material from the pouch when a predetermined pressure/force is applied to the pouch.
5. Container according to any one of claims 1 to 4, **characterized** in that the pouch is fastened to the bottom portion via an adhesive or via a weld.

6. Container according to any one of claims 1 to 5, **characterized** in that the container further comprises an intermediate holding element arranged to fasten the pouch to the bottom portion of the container.
- 5 7. Container according to claim 6, **characterized** in that said intermediate holding element is a planar element having a planar surface area essentially corresponding to the surface area of an inside surface of the bottom portion.
- 10 8. Container according to claim 6 or 7 **characterized** in that the pouch is fastened to an upper surface of the intermediate holding element via a weld or via an adhesive.
- 15 9. Container according to any one of claims 6 or 7, **characterized** in that the pouch is fastened to the intermediate holding element via a mechanical gripping mechanism.
- 20 10. Container according to any one of claims 1 to 9, **characterized** in that the second material is a liquid.
- 25 11. Container according to any one of claims 1 to 10, **characterized** in that the container is arranged such that an implement can be inserted into the first material which pierces the pouch or causes the pouch to rupture/burst when force is applied.
- 30 12. Container according to any one of claims 1 to 11, **characterized** in that the container is arranged such that in order to rupture the pouch, it is necessary to insert an implement into the first material to agitate the first material and/or apply pressure directly to the pouch.

13. Container according to claims 11 or 12, **characterized** in that the container is arranged such that the implement is inserted into the first material via the opening (8) of the container.
- 5 14. Container according to any one of claims 1 to 13, **characterized** in that the area of the opening (8) of the container is larger than the area of the inside surface (14) of the bottom portion (4).
- 10 15. Container according to any one of claims 1 to 14, **characterized** in that the first material is a material for forming a surface covering of a building, for example a mortar material, a filler material and a paint like material.

1/5

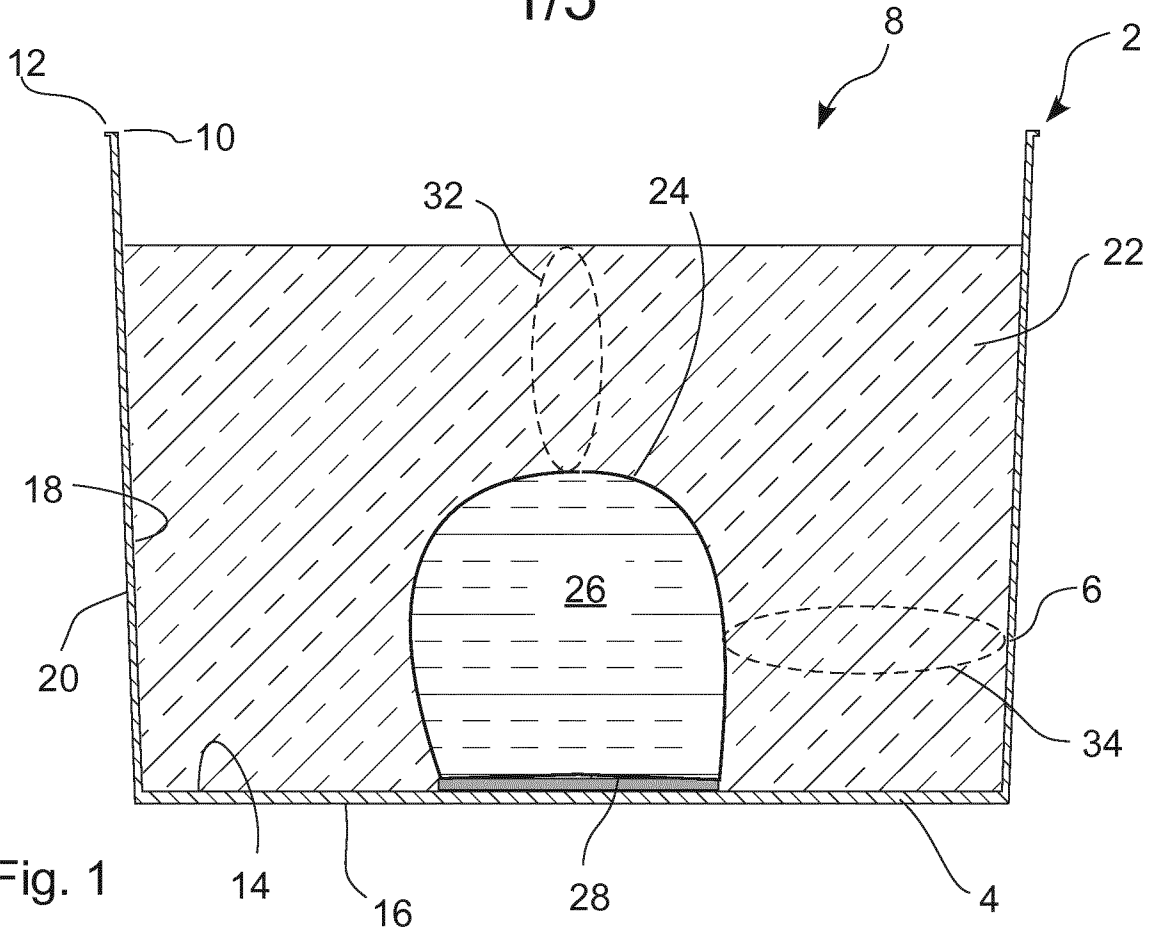

Fig. 1

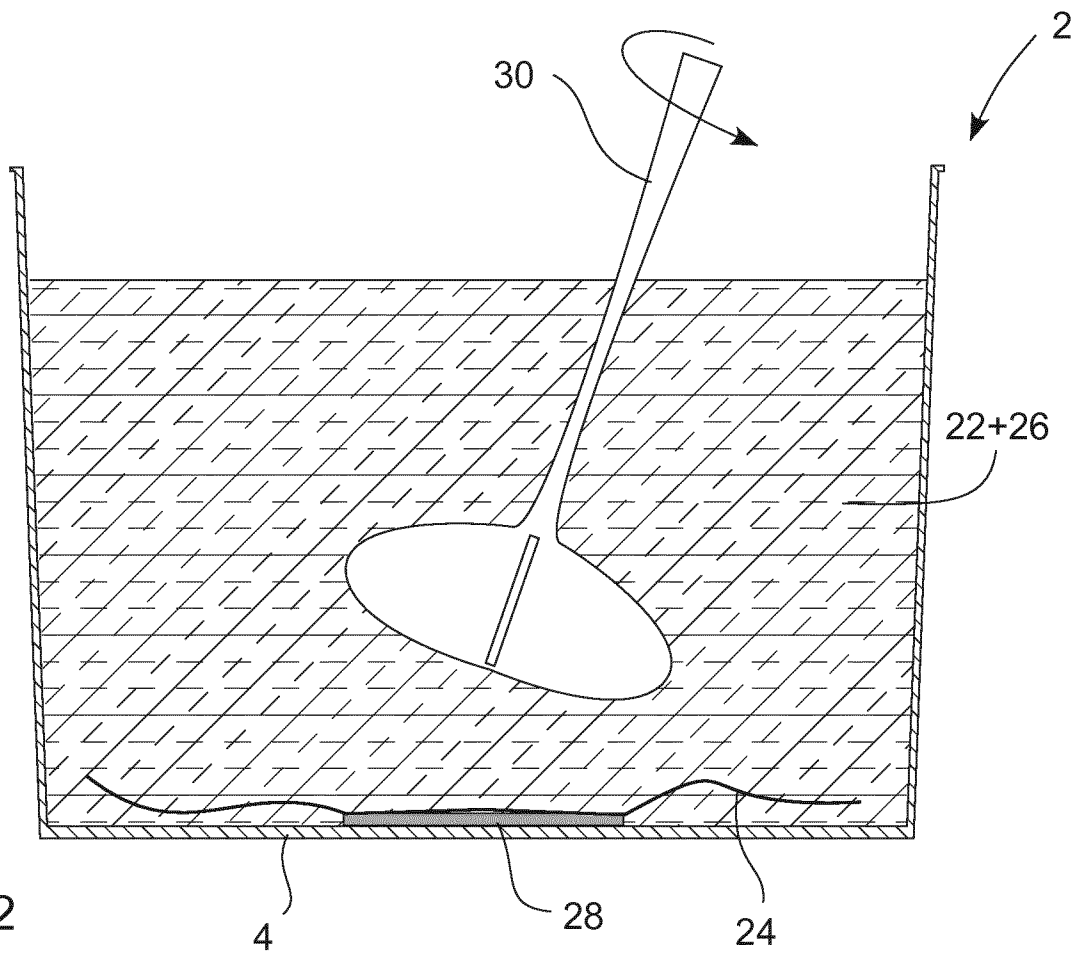

Fig. 2

2/5

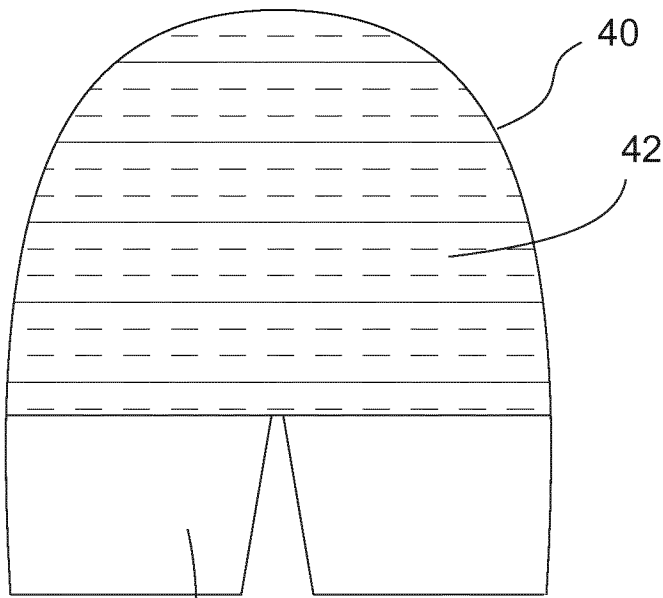

Fig. 3

44

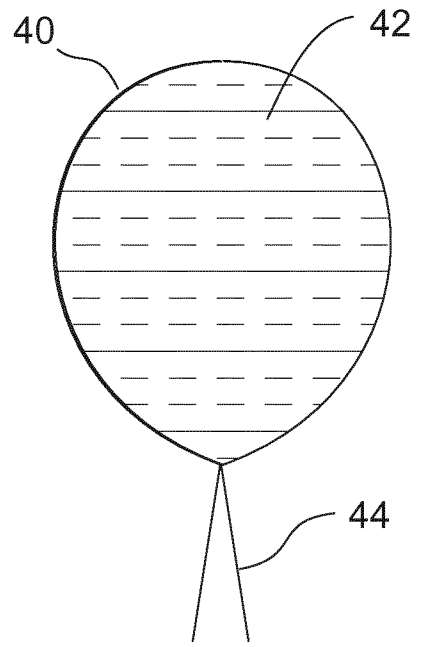

Fig. 4

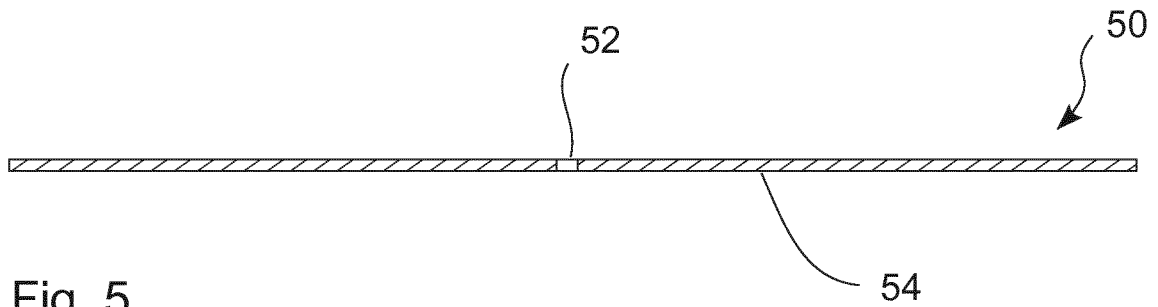

Fig. 5

54

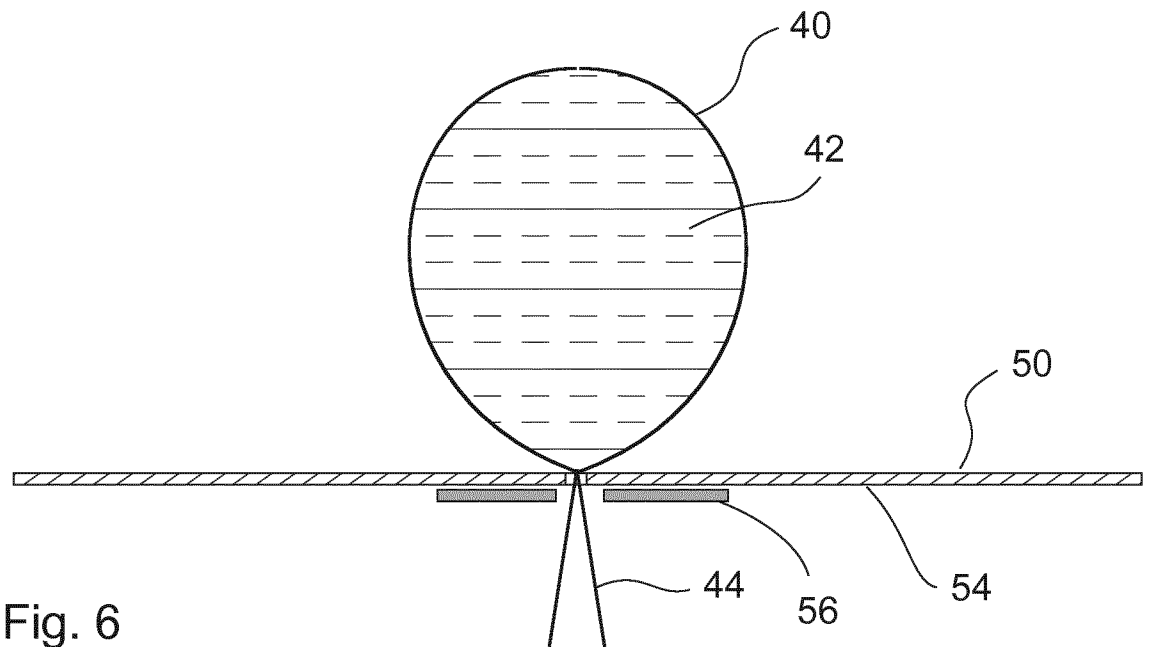

Fig. 6

44

56

54

3/5

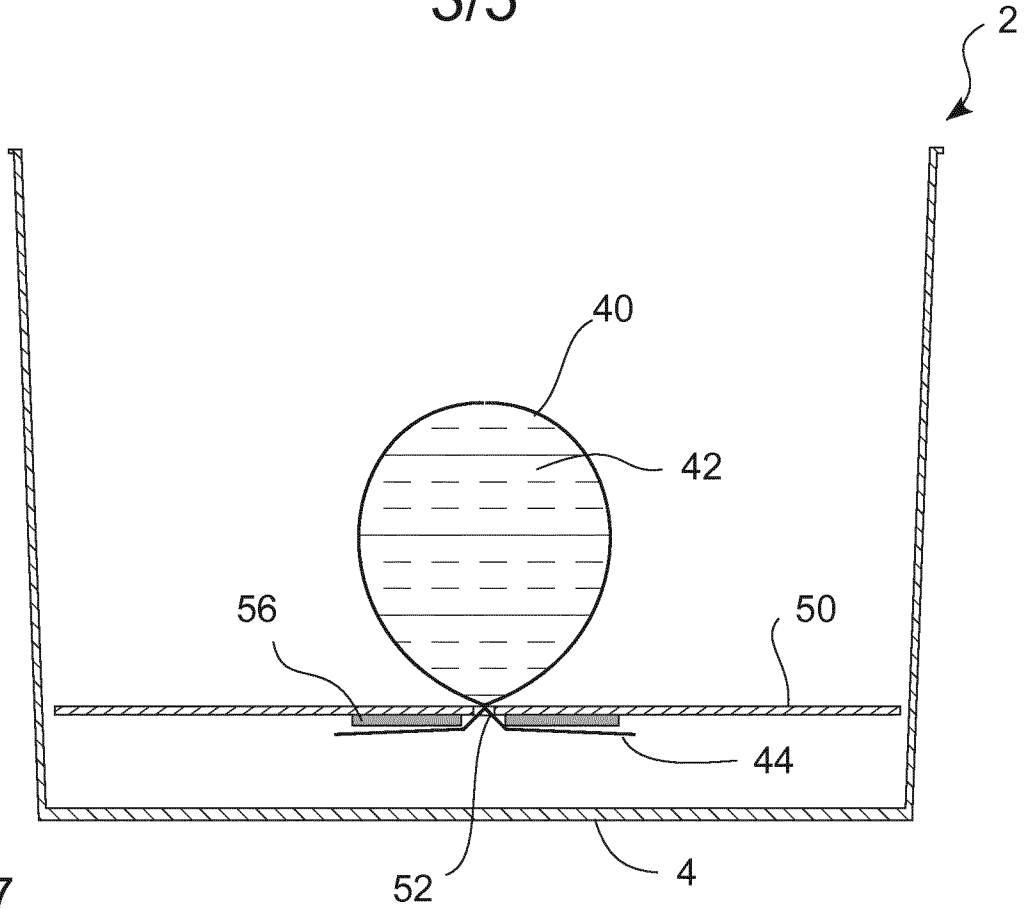

Fig. 7

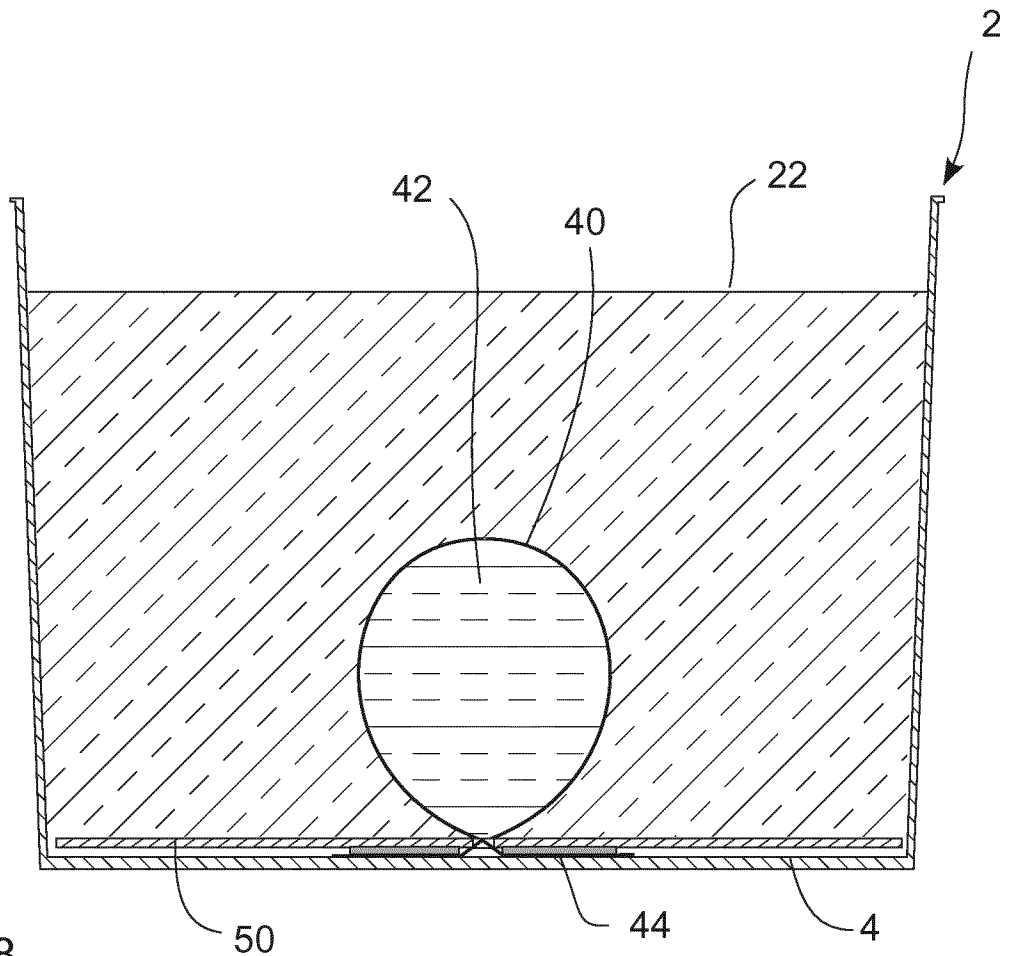

Fig. 8

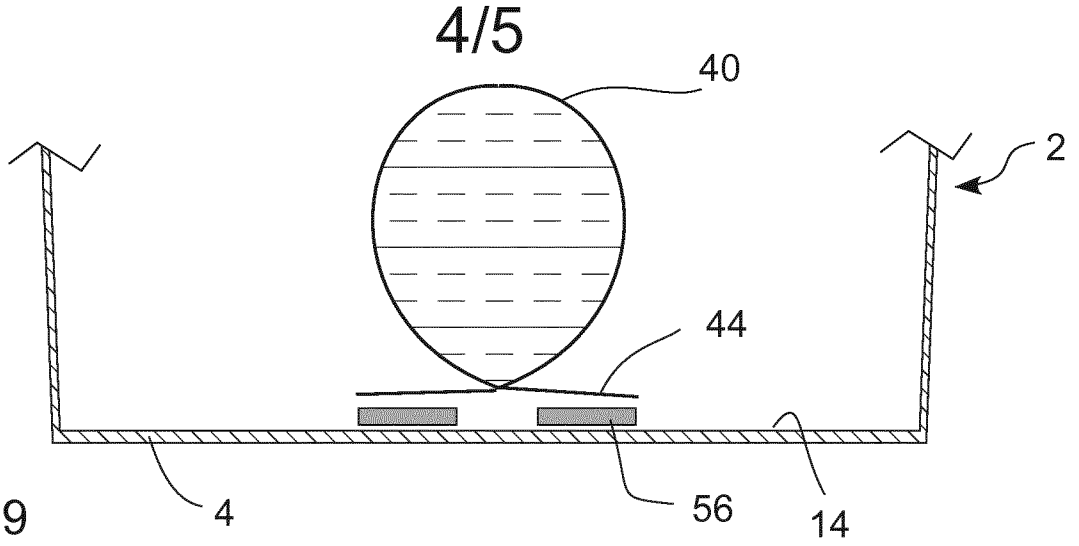

Fig. 9

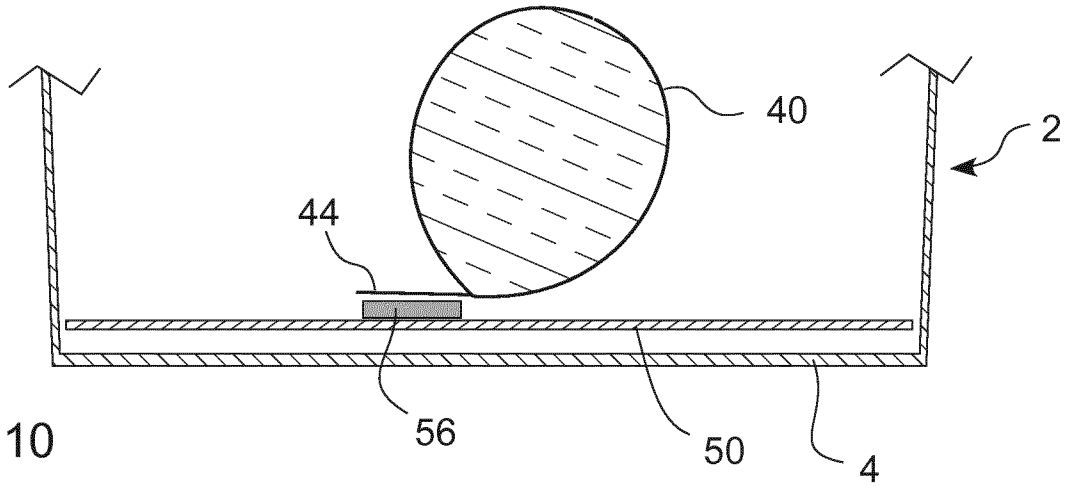

Fig. 10

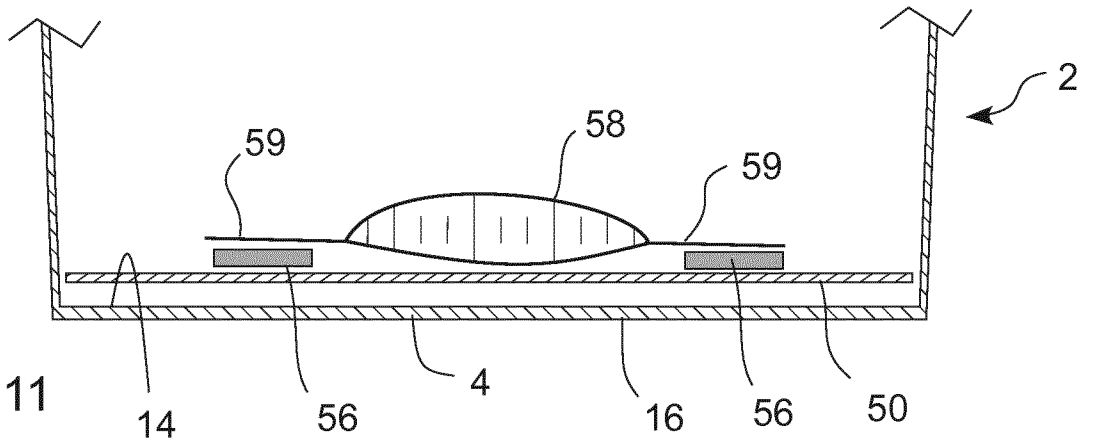

Fig. 11

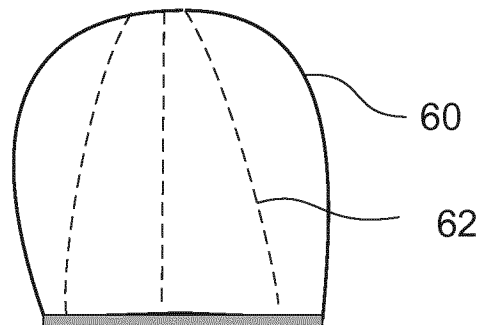

Fig. 12

5/5

Fig. 13

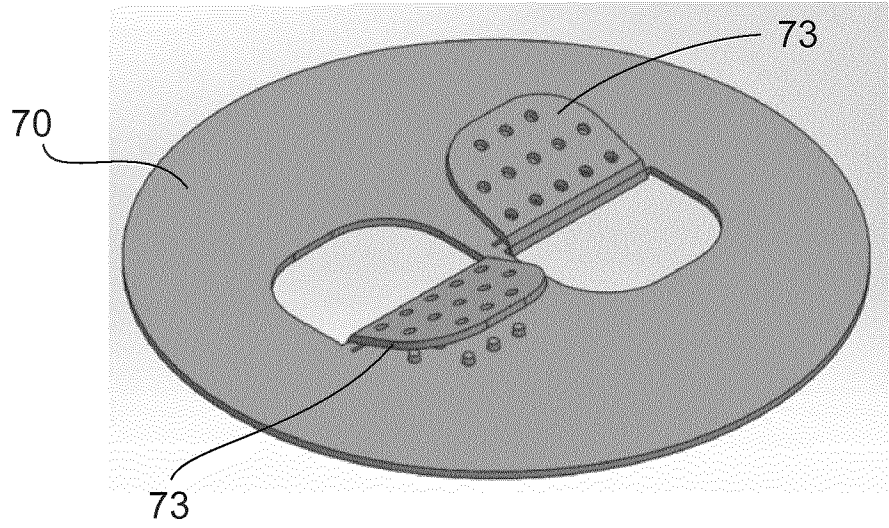

Fig. 14

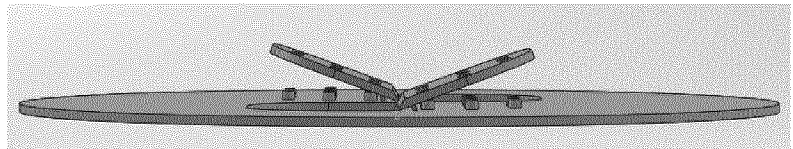

Fig. 15

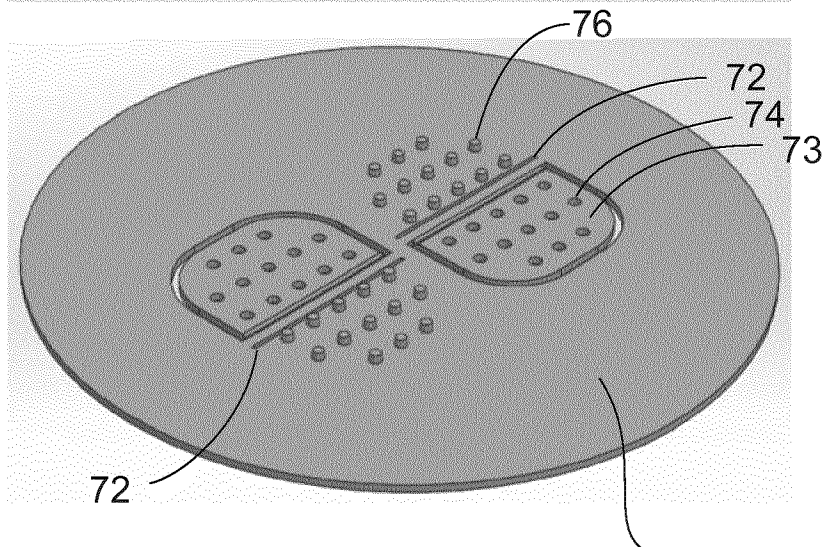
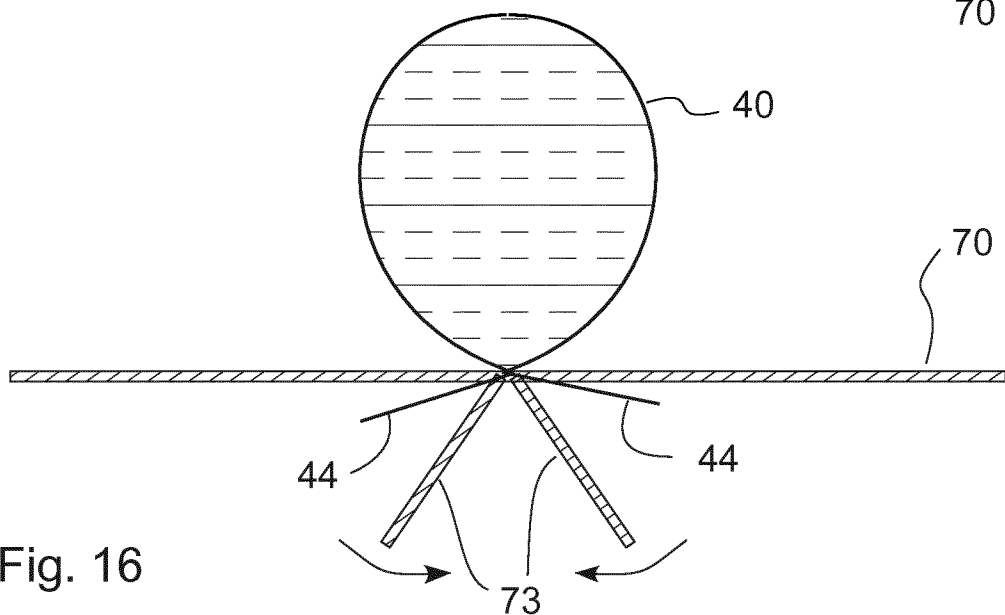

Fig. 16



INTERNATIONAL SEARCH REPORT

International application No
PCT/EP2018/057205

A. CLASSIFICATION OF SUBJECT MATTER
INV. B65D81/32
ADD.

According to International Patent Classification (IPC) or to both national classification and IPC

B. FIELDS SEARCHED
Minimum documentation searched (classification system followed by classification symbols)
B65D

Documentation searched other than minimum documentation to the extent that such documents are included in the fields searched

Electronic data base consulted during the international search (name of data base and, where practicable, search terms used)
EPO-Internal, WPI Data

C. DOCUMENTS CONSIDERED TO BE RELEVANT

Category*	Citation of document, with indication, where appropriate, of the relevant passages	Relevant to claim No.
X	DE 14 86 622 A1 (SPIESS C F & SOHN) 17 July 1969 (1969-07-17)	1-3,5, 10-13,15
Y	page 3, paragraph 3 - page 4, paragraph 1; figures 1, 3, 6 page 2, paragraph 2 - paragraph 4 page 6, paragraph 2 page 9, paragraph 2	4
X	----- GB 2 531 047 A (CHARLOTTE WELCH [GB]) 13 April 2016 (2016-04-13)	1-3,5,10
Y	figure 4	4
A	----- EP 2 177 456 A1 (SCHOELLER ARCA SYSTEMS GMBH [DE]) 21 April 2010 (2010-04-21) paragraphs [0002], [0010]; figure 1 -----	1-5, 10-13,15

Further documents are listed in the continuation of Box C.

See patent family annex.

* Special categories of cited documents :

- "A" document defining the general state of the art which is not considered to be of particular relevance
- "E" earlier application or patent but published on or after the international filing date
- "L" document which may throw doubts on priority claim(s) or which is cited to establish the publication date of another citation or other special reason (as specified)
- "O" document referring to an oral disclosure, use, exhibition or other means
- "P" document published prior to the international filing date but later than the priority date claimed

- "T" later document published after the international filing date or priority date and not in conflict with the application but cited to understand the principle or theory underlying the invention
- "X" document of particular relevance; the claimed invention cannot be considered novel or cannot be considered to involve an inventive step when the document is taken alone
- "Y" document of particular relevance; the claimed invention cannot be considered to involve an inventive step when the document is combined with one or more other such documents, such combination being obvious to a person skilled in the art
- "&" document member of the same patent family

Date of the actual completion of the international search

15 May 2018

Date of mailing of the international search report

23/07/2018

Name and mailing address of the ISA/
European Patent Office, P.B. 5818 Patentlaan 2
NL - 2280 HV Rijswijk
Tel. (+31-70) 340-2040,
Fax: (+31-70) 340-3016

Authorized officer

Czerny, M

INTERNATIONAL SEARCH REPORT

Information on patent family members

International application No

PCT/EP2018/057205

Patent document cited in search report	Publication date	Patent family member(s)	Publication date
DE 1486622	A1	17-07-1969	NONE

GB 2531047	A	13-04-2016	GB 2531047 A 13-04-2016
			GB 2532130 A 11-05-2016

EP 2177456	A1	21-04-2010	DE 102008051944 A1 22-04-2010
			EP 2177456 A1 21-04-2010

INTERNATIONAL SEARCH REPORT

International application No.
PCT/EP2018/057205

Box No. II Observations where certain claims were found unsearchable (Continuation of item 2 of first sheet)

This international search report has not been established in respect of certain claims under Article 17(2)(a) for the following reasons:

1. Claims Nos.:
because they relate to subject matter not required to be searched by this Authority, namely:

2. Claims Nos.:
because they relate to parts of the international application that do not comply with the prescribed requirements to such an extent that no meaningful international search can be carried out, specifically:

3. Claims Nos.:
because they are dependent claims and are not drafted in accordance with the second and third sentences of Rule 6.4(a).

Box No. III Observations where unity of invention is lacking (Continuation of item 3 of first sheet)

This International Searching Authority found multiple inventions in this international application, as follows:

see additional sheet

1. As all required additional search fees were timely paid by the applicant, this international search report covers all searchable claims.

2. As all searchable claims could be searched without effort justifying an additional fees, this Authority did not invite payment of additional fees.

3. As only some of the required additional search fees were timely paid by the applicant, this international search report covers only those claims for which fees were paid, specifically claims Nos.:

4. No required additional search fees were timely paid by the applicant. Consequently, this international search report is restricted to the invention first mentioned in the claims; it is covered by claims Nos.:

1-5, 10-13, 15

Remark on Protest

- The additional search fees were accompanied by the applicant's protest and, where applicable, the payment of a protest fee.
- The additional search fees were accompanied by the applicant's protest but the applicable protest fee was not paid within the time limit specified in the invitation.
- No protest accompanied the payment of additional search fees.

FURTHER INFORMATION CONTINUED FROM PCT/ISA/ 210

This International Searching Authority found multiple (groups of) inventions in this international application, as follows:

1. claims: 1-5, 10-13, 15

Container for allowing mixing of two separate materials

1.1. claims: 1-5, 10, 15

A rupturable pouch being arranged within a container

1.2. claims: 11-13

An implement is provided to burst the pouch or to agitate the first material

2. claims: 6-9

Provision of an intermediate holding element

3. claim: 14

Provision of a specific geometry of the container
