

(No Model.)

2 Sheets—Sheet 1.

G. M. BEARD.

WINDMILL.

No. 299,327.

Patented May 27, 1884.

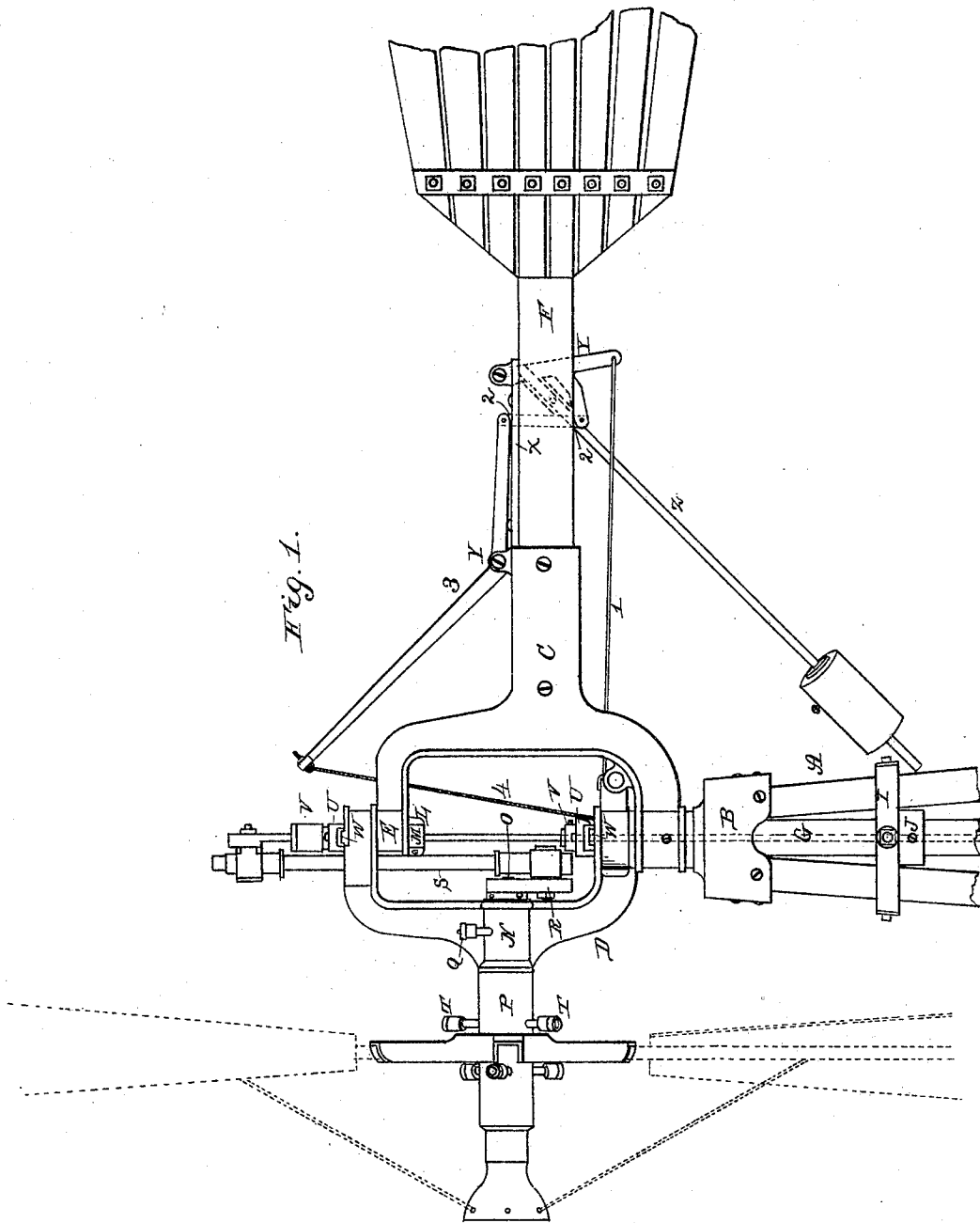

Witnesses:

*J. W. Garner*  
*W. S. O'Haines*

Inventor:

*Geo. M. Beard,*  
*per*  
*J. A. Lehmann, atty.*

(No Model.)

2 Sheets—Sheet 2.

G. M. BEARD.

WINDMILL.

No. 299,327.

Patented May 27, 1884.

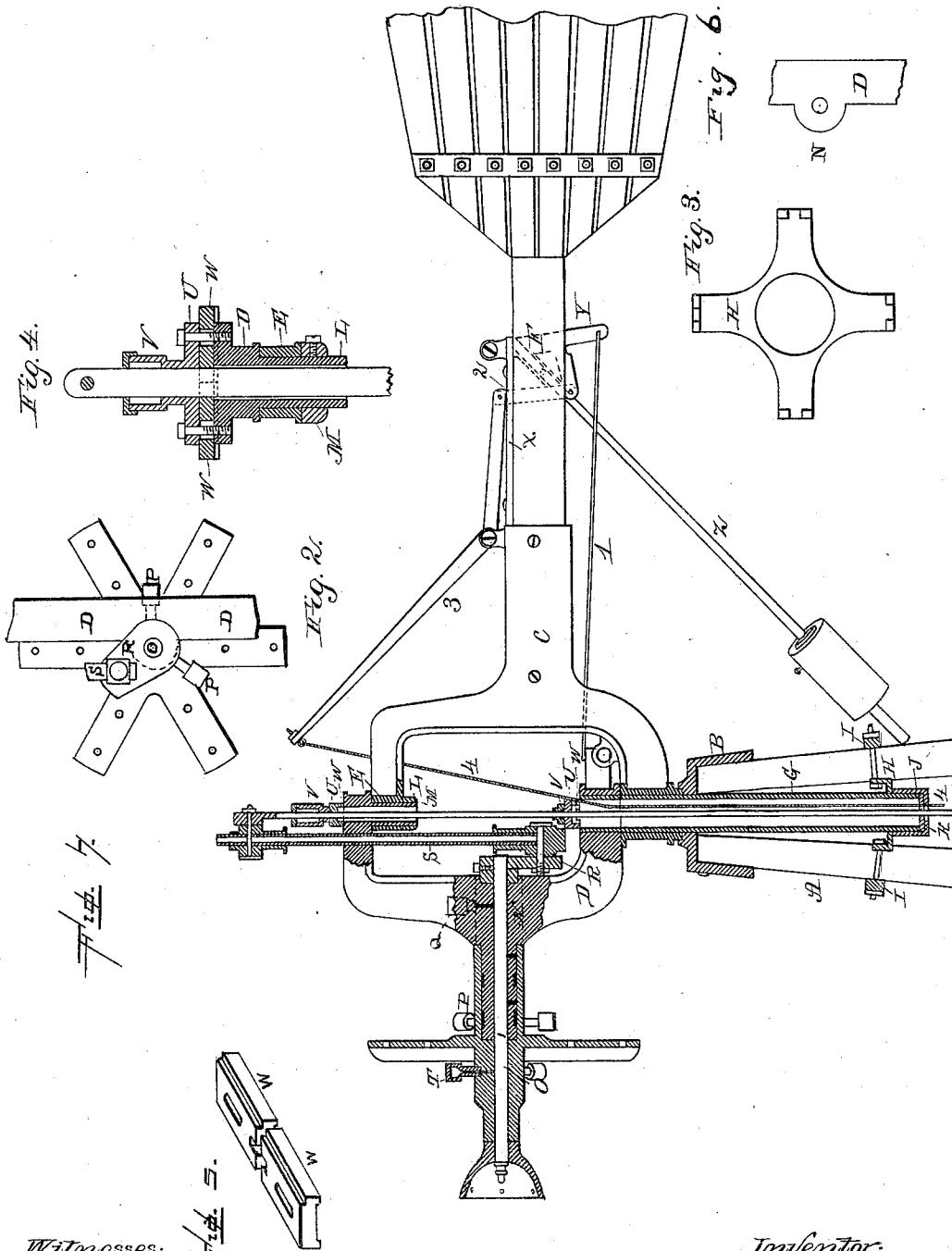

Witnesses:

*J. W. Garner*  
*H. S. D. Haines*

Inventor:

*Geo. M. Beard,*  
*per*  
*J. A. Lehmann, atty*

# UNITED STATES PATENT OFFICE.

GEORGE M. BEARD, OF AUBURN, INDIANA.

## WINDMILL.

SPECIFICATION forming part of Letters Patent No. 299,327, dated May 27, 1884.

Application filed September 7, 1883. (No model.)

*To all whom it may concern:*

Be it known that I, GEORGE M. BEARD, of Auburn, in the county of De Kalb and State of Indiana, have invented certain new and useful Improvements in Windmills; and I do hereby declare the following to be a full, clear, and exact description of the invention, such as will enable others skilled in the art to which it pertains to make and use it, reference being had to the accompanying drawings, which form part of this specification.

My invention relates to an improvement in windmills; and it consists, first, in the combination of the guides provided with oil-cups upon their tops; second, in the combination of the pump-rod with the guides and the slotted adjustable plates for bearing against the rod; third, in the arrangement and combination of parts, to be more fully described hereinafter.

Figure 1 is a side elevation showing a windmill which embodies my invention complete. Fig. 2 is a vertical longitudinal section of the upper portion of the mill and the castings. Fig. 3 is a detail view of the spider by which the mill is centered in position. Fig. 4 is a detail sectional view. Fig. 5 is a perspective of two of the adjusting-plates shown in their proper relation to each other. Fig. 6 is a detail view showing the bearing for the wheel placed to one side of the casting. Fig. 7 is a similar view to Fig. 6, showing the crank attached to one end of the shaft and the wheel to the other.

A represents the frame; B, the casting which is secured upon its top; C, the casting to which the vane is secured, and D the casting upon which the wheel is journaled. The casting C extends upward so as to form a bearing, E, for the upper part of the casting D, and has a suitable rearward extension, to which the vane F is bolted in the usual manner. Either formed as a part of this casting C or secured thereto is the pipe G, which projects downward through the casting B and the spider H, which is located in the frame A. This spider consists of the casting having an opening through its center to allow the lower end of the pipe to pass through it, and which is held in place by means of set-screws which pass

outward through flanges formed upon the casting, and the cross-bars I, which are clamped by the bolts or screws against the outer sides of the frame. By means of the spider H the lower end of the pipe G can be adjusted from side to side, so as to always hold the mill in a vertical position. Upon the lower end of this pipe is secured the collar J, which bears against the under side of the spider H, and serves to swivel the pipe G in position and to prevent the mill from being raised upward. Inside of this collar J is placed a guide, K, for the lower end of the pump-rod. This guide serves to keep the pump-rod always in a vertical position and prevents any side-play. The casting D, which supports the wheel, fits over the upper end of the pipe G, extends up above the top of the lower part of the casting C, and has a tubular portion, L, which passes down through the guide E, as shown. The two castings C D are secured together by means of the collar M, which is secured to the lower end of the part L by means of a set-screw. When it is desired to separate the two castings C D, it is only necessary to remove this collar M, when the casting D can be lifted upward entirely separate from the casting C, upon which it is supported. Instead of the bearing for the shaft being constructed in one solid piece, as has heretofore been the case, the casting D is provided with a horizontal tube, N, for the shaft O to pass through, and this tube N is set to one side of the center of the casting, so as to throw the wheel to one side, and thus cause the wheel to move around out of the wind, in the usual manner. The tube N, being a part of the casting D, is cast upon one side of it, as shown in Figs. 6 and 7, instead of at its center. This tube N will be provided with suitable grooves in its outer side, and has suitable openings made through it, so as to let the oil which is fed through the casting D from the oil-cup Q pass through the casting upon the shaft O. The oil which passes through the opening in the tube N is caught by the sleeve P, and is held in the grooves made in the outer side of the tube N, so as to keep the sleeve P always well lubricated. The sleeve P is secured to the shaft O at its outer end, and the shaft has

secured to its inner end the crank or eccentric R, for operating the pump-rod through the pitman S. This crank R has a sleeve or tube formed upon it, which fits in a corresponding socket in the casting D, and this crank serves to secure the shaft O in position. When the wheel is made to revolve by the wind, the sleeve carries the shaft around, and the shaft operates the crank in the usual manner. This sleeve upon the crank serves to form a tighter joint and to prevent any leakage of the oil at this point.

In order to prevent any waste of the oil used to lubricate the shaft O and the sleeve P, there is secured to or formed with the sleeve a number of pockets, T, into which the oil which has run into the sleeve drains whenever the mill is at rest. When the wheel again begins to revolve, these pockets empty the oil down upon the top of tube N, and thus serve to lubricate the parts perfectly. These pockets are provided with removable caps or covers, so that they can be cleaned out from time to time, when found necessary. Where there is nothing for the oil to drain into, the oil leaks away and becomes wasted. These pockets effect a great saving in this respect, as well as to instantly lubricate the moving parts just at the time when it is necessary.

The pitman S, instead of being made of a solid rod, as has heretofore been the case, is here made hollow, so as to hold sufficient oil to lubricate the wrist-pin and the bolt for securing the upper end of the pitman to the pump-rod. The wrist-pin and clamping-bolt pass directly through the ends of the pitman, as shown, the pitman being enlarged at these points. The oil is poured in through the top of the pitman, and can either pass around the clamping-bolt and wrist-pin by means of grooves made either in the bolt and wrist-pin themselves or in the inner sides of the pitman. The wrist-pin passes directly through the lower end of the pitman and through the crank, and receives a nut upon its inner end. Whenever the bearing-surface between the pitman and the crank becomes worn, they can be tightened together by simply tightening up the nut upon the wrist-pin; and this is equally true of the connection between the upper end of the pitman and the upper end of the pump-rod. The pump-rod passes down through suitable guides, U, which are bolted upon the casting D, and upon the top of each one of these guides U is formed an oil-cup, V, which is filled with any suitable material, so as to prevent the oil from leaking away too rapidly. Each of the guides U is grooved underneath, and in these grooves are placed the

slotted adjustable plates W, which are held in position by the same bolts which hold the guides in place. These adjustable plates W bear against opposite sides of the pump-rod, and serve to keep it always in a vertical position and to prevent any side movement.

Secured upon the top of the vane is a casting, X, upon the rear end of which is secured a bolt or rod, which serves as a journal for the triangular-shaped lever Y. Clamped against the outer side of this lever Y, which is provided with suitable bearings for that purpose, is the rod Z, upon which the sliding weight is placed, and which weight serves to pull the wheel back into the wind as soon as it is left free to move. One of the ends of this triangular lever Y is connected directly with the casting D by means of the rod I, while its other end is connected by means of the rod 2 with the lever 3, which is pivoted upon the front end of the casting X. The inner end of this lever 3 extends nearly over the center of the mill, and has connected to it the rod, cord, wire, or chain 4, by means of which the wheel can be turned around with its edge to the wind whenever it is desired to stop its movement. The casting D is provided with suitable projections, which prevent the wheel from moving too far in either direction, and these projections strike against rubber springs in order to prevent any unnecessary jarring or shaking.

Having thus described my invention, I claim—

1. In a windmill, the combination of the two castings C D and tube G, the casting C being provided with the bearing E, and having the end of the tube G to project above the top of its lower portion, and the casting D being provided with an opening in its lower end to catch over the top of the tube G, and having a tubular portion for passing down through the bearing E, substantially as shown.

2. The combination of the guides and the slotted adjusting-plates, which are made to bear against opposite sides of the pump-rod, substantially as described.

3. The combination of the vane and the triangular-shaped lever, which is connected with the casting D by means of a connecting-rod, and with an operating-lever, and which triangular-shaped lever has the weighted rod clamped to it, substantially as specified.

In testimony whereof I affix my signature in presence of two witnesses.

GEORGE M. BEARD.

Witnesses:

JOHN W. BAXTER,  
R. DEXTER TEEFT.