

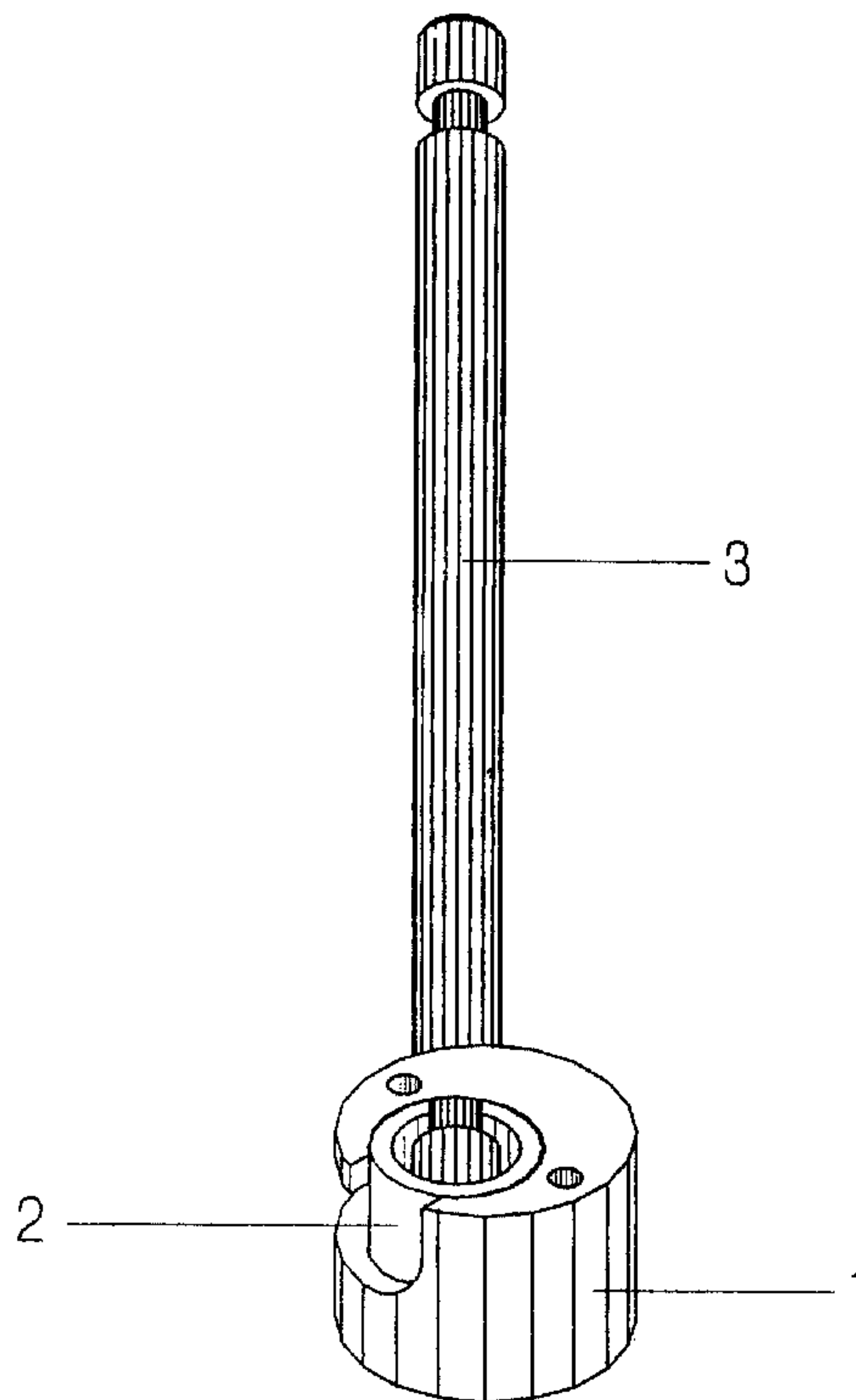

(86) Date de dépôt PCT/PCT Filing Date: 1999/10/14
 (87) Date publication PCT/PCT Publication Date: 2000/06/22
 (85) Entrée phase nationale/National Entry: 2001/06/14
 (86) N° demande PCT/PCT Application No.: DE 99/03336
 (87) N° publication PCT/PCT Publication No.: WO 00/36308
 (30) Priorité/Priority: 1998/12/15 (198 57 795.8) DE

(51) Cl.Int.⁷/Int.Cl.⁷ F16B 12/20
 (71) Demandeur/Applicant:
NIKLAUS, HILMAR, DE
 (72) Inventeur/Inventor:
NIKLAUS, HILMAR, DE
 (74) Agent: MCFADDEN, FINCHAM

(54) Titre : ASSEMBLAGE LIBERABLE DE DEUX ELEMENTS
 (54) Title: DETACHABLE ASSEMBLY OF TWO ELEMENTS



(57) **Abrégé/Abstract:**

The invention relates to a detachable assembly of two elements between which at least one shaft is arranged and which is secured on at least one end thereof to a holding fixture that is mounted on one of the elements. The holding fixture can be rotated, in relation to said element, around an axis that runs substantially perpendicular to the shaft. The holding fixture can be held in non-positive fit in each rotational position in relation to the shaft and/or element. The shaft (3) is secured to the holding fixture (1) and can be rotated around a distant axis that is approximately parallel to the axis of the holding fixture (1).

ABSTRACT

The invention relates to a detachable assembly of two elements between which at least one shaft is arranged and which is secured on at least one end thereof to a holding fixture that is mounted on one of the elements. The holding fixture can be rotated, in relation to said element, around an axis that runs substantially perpendicular to the shaft. The holding fixture can be held in non-positive fit in each rotational position in relation to the shaft and/or element. The shaft (3) is secured to the holding fixture (1) and can be rotated around a distant axis that is approximately parallel to the axis of the holding fixture (1).

Detachable Connection of Two Elements

5 The invention relates to a detachable connection of
two elements, between which at least one bolt is
arranged and which is fixed at at least one end by
means of a tensioning body attached to one of the
elements, wherein the tensioning body is rotatable
with respect to the element about an axis extending
essentially perpendicular to the bolt, and the
10 tensioning body is adhesionaly fixed in each
rotational position with respect to the bolt and/or
to the element, and the fixing of the bolt on the
tensioning body is rotatable about an axis
distanced from the axis of the tensioning body and
15 approximately parallel thereto.

Such connections for joining two elements, in
particular of wood are known in the most diverse
embodiments and are often used in furniture for
producing corner connections. The bolt connects the
20 two elements to one another and is fixed on one
side by a tensioning body, which is usually
accommodated in a cavity of the furniture article.
The tensioning body usually has the form of a disc,
which is rotatable in a ring and to which the bolt
25 extends in a radial direction. To produce the
connection, the bolt is introduced through a slot
of the ring and the disc is rotated with respect to
the ring and the bolt about an axis perpendicular
to the disc plane, whereby a wedge integrally

moulded on the disc pushes through an eye of the bolt and pulls said eye inwards as it is rotated further in the radial direction of the disc. The radial outer edge of the wedge extends

5 approximately in the form of a circular arc, whose centre lies on the axis of rotation, as a radial delimitation of the disc along the ring, while the radial distance of the inner wedge edge, which bears against the eye, decreases progressively

10 further from the axis of rotation of the disc, so that the eye is drawn inwards in the radial direction. In WO 97/32140, the tensioning of the bolt is carried out by means of a rotatable cylindrical sleeve, in which an eccentric recess is

15 provided, which receives the head of the bolt. On rotation of the sleeve, the different edge thicknesses of the across the azimuth engage behind the head of the bolt, tensioning it more or less in an axial direction. At its other end, the bolt is

20 fastened to another element, usually a lateral furniture wall, which, by tensioning of the bolt, is tightened against the element provided with the tensioning body. Friction between the disc and ring, but also between the disc and bolt, fixes the

25 disc in the respective position. It is disadvantageous, however, that the tensioning body only bears against the rear end of the eye and can thereby transmit only tension forces to the bolt. With such connections, the bolt must stand

30 constantly under tension, resulting in relatively

high material fatigue. In addition, if the connection is to be detached again subsequently, no pressure load can be exerted via the bolt to force the elements apart. The elements would thus have to be forced apart with other tools.

The present invention has set itself the object of providing a detachable connection between elements in which both tension and pressure forces can be transmitted between the elements via a bolt.

This object is achieved according to the invention in that the connection between the bolt and tensioning body is produced by means of a retaining head, which is attached detachably on the bolt and is rotatable relative to the tensioning body. The fastening between the bolt and tensioning body is achieved by means of a retaining head, which is detachably connected to the bolt and rotates with the bolt with respect to the tensioning body. Since the bolt in this case does not need to bear any necessary measures for producing a rotatable connection, it can also be shaped in such a way that it can even be inserted through narrow channels.

The effect is that of an eccentric, via which the bolt is drawn or pushed in its longitudinal

direction depending on the direction of rotation of the tensioning body. The maximum possible distance through which the bolt can be tensioned corresponds to twice the eccentricity.

5 As with the connections for furniture known from the state of the art, with the connections according to the invention, the bolt may also be fastened at its opposite end from the tensioning body to the other element. Alternatively the other
10 end of the bolt may also be attached in the described manner to another tensioning body. Apart from the increase of the distance over which a tensioning of the bolt is possible, a tensioning force can be transmitted directly to both elements
15 through the tensioning body attached thereto. This tensioning force would in some circumstances be partly taken up by the guide of the bolt.

As is already the case in the state of the art, with the connection according to the invention, the
20 tensioning body can be secured against reverse rotation by friction occurring between the tensioning body and the element or else between the tensioning body and the bolt. If possible, however, the frictional force should act both through the
25 bolt and through the element on the tensioning body, so that the fixing is more stable to loads.

By the fact that the bolts penetrates an element to a certain length, a tensioning of the articles with

respect to one another is possible over a relatively long distance. The connection is thereby stable to shaking even with relatively low tensioning forces. ...

5 It is also possible that the bolt may penetrate a third element arranged between the two elements. Thereby it is possible to produce a cross connection or a post-and-crossbar connection. The first and second element may be formed by, for
10 example, the post or the vertical crossbolt, whereas the third element is represented by the crossbar or horizontal crossbolt arranged between the aforesaid first and second elements. Alternatively it is also conceivable that the third
15 element forms the post or vertical crossbolt.

As is known in the state of the art, the tensioning body may be fastened on an element by accommodating it in a cavity. In order that both tension and pressure forces can be transmitted to the bolt, the
20 tensioning body must be fixed in the longitudinal direction of the bolt at both ends by the cavity.

The retaining head can be permanently fastened on the tensioning body. Preferably, however, it is detachably connected to the tensioning body. When a
25 repair is due it is possible only to exchange the retaining head or the tensioning body individually, and by exchanging the tensioning body a different

eccentricity can be achieved with one and the same retaining head.

5 The bolt is preferably fixed in the retaining head by means of an axially extending slot whose flanks engage at both sides of the bolt in an azimuthally extending groove. It is conceivable that both flanks engage in the same groove, which surrounds the bolt through an angle of more than 180° , or that the bolt has two azimuthally grooves lying approximately radially opposite one another.

10 Because of the axial alignment of the slot with respect to the tensioning body, the bolt is fixed in its longitudinal direction and, with rotation of the tensioning body, since the slot is aligned parallel to the two axes of rotation, no force component occurs in the longitudinal of the slot, through which the bolt could move along the slot and in the process detach from the retaining head. Here, it is simple to produce the connection
15 between the bolt and retaining head by introducing the bolt into an opening of the slot. The handling of the bolt is by no means impaired by the groove.

20 In the ideal case, the groove of the bolt is to be embodied as a surrounding annular groove. In this case, the connection can be produced independently of the orientation of the tensioning body and retaining head relative to the longitudinal direction of the bolt.

A stable connection with a large contact area between the bolt end or retaining head and the tensioning body can be achieved by means of an extra-axial cavity accommodated in the tensioning body, in which cavity the retaining head or bolt end is to be accommodated such that it is fixed in the longitudinal direction of the bolt and can transmit both tension and pressure forces to the bolt.

In order that the tensioning body is not wedged by means forces acting via the bolt, the bolt on the tensioning body should be attached as far as possible centrally on the tensioning body with respect to its longitudinal direction. For this reason, the tensioning body has, for automatic alignment, an azimuthally extending slot which the bolt penetrates. A tensioning body with this feature may be of greater axial extension, which makes wedging even more difficult.

In order that, in the case of a tensioning body with azimuthally extending slot, the introduction of the bolt is simplified, the tensioning body additionally has an essentially axially extending slot, whose width, in order to allow introduction of the bolt, must be larger than the diameter of the bolt. In particular, this feature appears appropriate in combination with a slot of the retaining head, said slot extending essentially in an axial direction of the tensioning body and

receiving the bolt. For introduction of the bolt,
the retaining head is twisted in the tensioning
body such that the two axially extending slots lie
one behind the other in the radial direction. The
5 bolt can now be introduced simultaneously both into
the retaining head and into the tensioning body.
After twisting of the tensioning body relative to
the retaining head the bolt is fixed by the
azimuthal slot of the tensioning body against a
10 movement in the longitudinal direction of the slot
produced in the retaining head.

For both the cavity of the element, in which the
tensioning body is rotatably mounted and the cavity
of the tensioning body in which the retaining head
15 is rotatably mounted, the shape of a cylinder is to
be preferred. But also the outer contour of the
tensioning body or retaining head is preferably
formed in this shape in order that, in the case of
a relatively large contact surface between the
20 cavity of the element and the tensioning body or
between a cavity of the tensioning body and the
retaining head, the effect of the eccentric can be
achieved. All the contours mentioned in this
context are in the ideal case cylindrical.

25 Preferably a cavity of the element or of the
tensioning body should be designed open at one
axial side in order that it is accessible for
introduction of the tensioning body or for
producing the connection, and any repair work

subsequently becoming due can be performed more easily.

The external appearance however is more appealing than in the case of locked cavities. In addition,
5 by closure of a cavity it is achieved that the tensioning body or retaining head cannot become detached in an undesirable manner. It is also conceivable to combine the advantages of a closed
10 cavity with those of an open cavity by forming the cavity open at one side and closed at the other side.

Other details, features and advantages of the invention can be derived from the following
15 descriptive part, which describes a typical embodiment of the invention with the aid of drawings, wherein, in diagrammatic view

Figure 1 shows the individual parts of the connection according to the invention,
and

20 Figure 2 shows the individual parts in assembled form.

Figure 1 shows the connection according to the invention in perspective exploded view. It is formed by a bolt (3), which is fastened in a
25 tensioning body (1) by means of a retaining head (2). The tensioning body (1) contains, offset with respect to its axis of rotation, a cylindrical

cavity (4) to receive the retaining head (2) and therewith the bolt (3), as well as an azimuthal slot (5), through which the bolt (3) is guided outwards from the cavity (4), and an axial slot (6) for introduction of the bolt (3) on production of the connection. The retaining head (2) has the form of a hollow cylinder whose diameter is slightly smaller than the cavity (4) accommodated in the tensioning body (1) and has an axial slot (7) for receiving the bolt (3), which for its part is provided, in the vicinity of the end facing the tensioning body (19), with a groove (8), shown here as a surrounding annual groove, extending azimuthally with respect to the bolt (3), which groove is received to produce the connection from the axial slot (7) of the retaining head (2). As a result of the formation of the azimuthal groove (8) of the bolt (3) as surrounding annual groove, the connection can be made for any rotation angle of the bolt (3) about its axis.

At its other end, the bolt (3) also has a surrounding annual groove and can there be fixed on a further element or attached via a detachable connection similar to the way described. There are two possibilities for introducing the bolt (3) into the tensioning body (1): One consists in first introducing the retaining head (2) into the cavity (4) of the tensioning body (1) such that the axes of the retaining head (2) and cavity (4) become

congruous and then twisting the retaining head (2) and tensioning body (1) with respect to one another about the axis of the cavity (4) or retaining head (2) such that the axial slot (7) of the retaining head (2) is aligned in an approximately radial direction behind the axial slot (6) of the tensioning body (1). Now the bolt (3) is introduced in the axial direction of the tensioning body (1) or retaining head (2) into the two axial slots (6 and 7, respectively) such that its groove (8) is received by the axial slot (7) of the retaining head (2). After the tensioning body (1) is twisted about its axis with respect to the retaining head (2), the bolt (3) penetrates the azimuthal slot (5) of the tensioning body (1). The other possibility consists in first introducing the bolt (3) via the groove (8) into the slot (7) of the retaining head (2) via the axial slot (6) into the tensioning body. After the tensioning body (1) has been twisted about its axis, the same result is obtained.

Figure 2 shows tensioning body (1), retaining head (2) and bolt (3) assembled in perspective view. In one axial direction, the retaining head is now fixed, because the cavity (4) of the tensioning body (1) there is closed in the other axial direction by the bolt (3), which for its part is fixed in the axial direction of the tensioning body by virtue of its azimuthal slot (5). The tensioning

body (1) is in turn accommodated in an approximately cylindrical cavity of the element, whose cylinder diameter is slightly greater than that of the tensioning body (1). For transmitting tension or pressure forces (1) to the bolt (3), the tensioning body (1) is twisted in the cavity of the element, as a result of which the axis of rotation of the retaining head (2), by virtue of the fact that it is accommodated in an eccentrically arranged cavity (4) of the retaining head (2), describes a circular arc. The rotation of the tensioning body (1) compensates the retaining head (2) by a contra-rotation about its axis of symmetry, and in the process, depending on the direction of rotation, transmits tension or pressure forces to the bolt (3). If the mutually contacting surfaces of the elements, of the tensioning body (1) and of the retaining head (2) are not too smooth, the tensioning body (1) is fixed in any rotational position by friction with the element or with the retaining head (2).

Overall, a detachable connection between two elements is obtained, by means of which, by means of a tensioning body (1) via a bolt (3), both tension and pressure forces can be transmitted.

P A T E N T C L A I M S

=====

1. Detachable connection of two elements and at least one bolt (3) arranged therebetween, which is fixed at at least one end via a tensioning body (1) attached to the element, the tensioning body (1) being rotatable with respect to the element about an axis extending essentially perpendicular to the bolt (3) and the tensioning body (1) being fixed in any rotational position with respect to the bolt (3) and/or to the element by adhesion, and the fastening of the bolt (3) on the tensioning body (1) being rotatable about an axis that is distanced from the axis of the tensioning body (1) and approximately parallel thereto, **wherein** the connection between the bolt (3) and tensioning body (1) being produced by means of a retaining head (2), which is attached detachably to the bolt (3) and is rotatable relative to the tensioning body (1).
2. Connection according to claim 1, **wherein** the bolt (3) is fastened at its other end to the other element.
3. Connection according to claim 1, **wherein**
- the bolt (3) is fixed at its other end by means of a further tensioning body attached to the other element,

- the other tensioning body is rotatable with respect to the other element about an axis extending essentially perpendicular to the bolt,
 - 5 - the fastening of the bolt (3) to the other tensioning body is rotatable about an axis distanced from the axis of this tensioning body and approximately parallel thereto, and
 - 10 - the other tensioning body is fixed in any rotational position with respect to bolt (3) and/or the other element by adhesion.
4. Connection according to one of the preceding claims, **wherein** the adhesion is frictional locking.
 - 15 5. Connection according to one of the preceding claims, **wherein** the bolt (3) penetrates at least one of the elements along a certain length.
 - 20 6. Connection according to one of the preceding claims, **wherein** the bolt (3) penetrates a third element that is arranged between the two elements.
 - 25 7. Connection according to one of the preceding claims, **wherein** the tensioning body (1) is accommodated in a cavity of the element that fixes the tensioning body (1) at both sides in the longitudinal direction of the bolt (3).

8. Connection according to claim 1, **wherein** the retaining head (2) is also detachably connected to the tensioning body (1).
- 5 9. Connection according to claim 8 or 1, **wherein** the retaining head (2) has a slot extending essentially in the axial direction of the tensioning body (1), whose flanks engage on both sides of the bolt (3) in a groove (8) extend in an azimuthal direction of the bolt (3).
- 10 10. Connection according to claim 9, **wherein** the azimuthally extending groove (8) of the bolt (3) is a surrounding annular groove.
- 15 11. Connection according to one of the preceding claims, **wherein** the bolt (3), at its end, and/or the retaining head (2) is accommodated in an extra-axial cavity (4) of the tensioning body (1) and is fixed in the longitudinal direction of the bolt (3).
- 20 12. Connection according to one of the preceding claims, **wherein** the bolt (3) penetrates an azimuthally extending slot (5) of the tensioning body (1).

13. Connection according to claim 12, **wherein** there extends between an axial end face of the tensioning body (1) and the azimuthally extending slot (5) of the tensioning body (1) an essentially axial slot (6), whose width is greater than the diameter of the bolt (3).

5

14. Connection according to one of the preceding claims, **wherein** a cavity of the element and/or of the tensioning body (1) and/or the tensioning body (1) itself and/or the retaining head (2) is formed so as to be essentially cylindrical.

10

15. Connection according to one of the preceding claims, **wherein** a cavity of the element and/or of the tensioning body (1) is open on an axial end face.

15

16. Connection according to one of the preceding claims, **wherein** a cavity of the element and/or of the tensioning body (1) is closed on an axial end face.

20

1/2

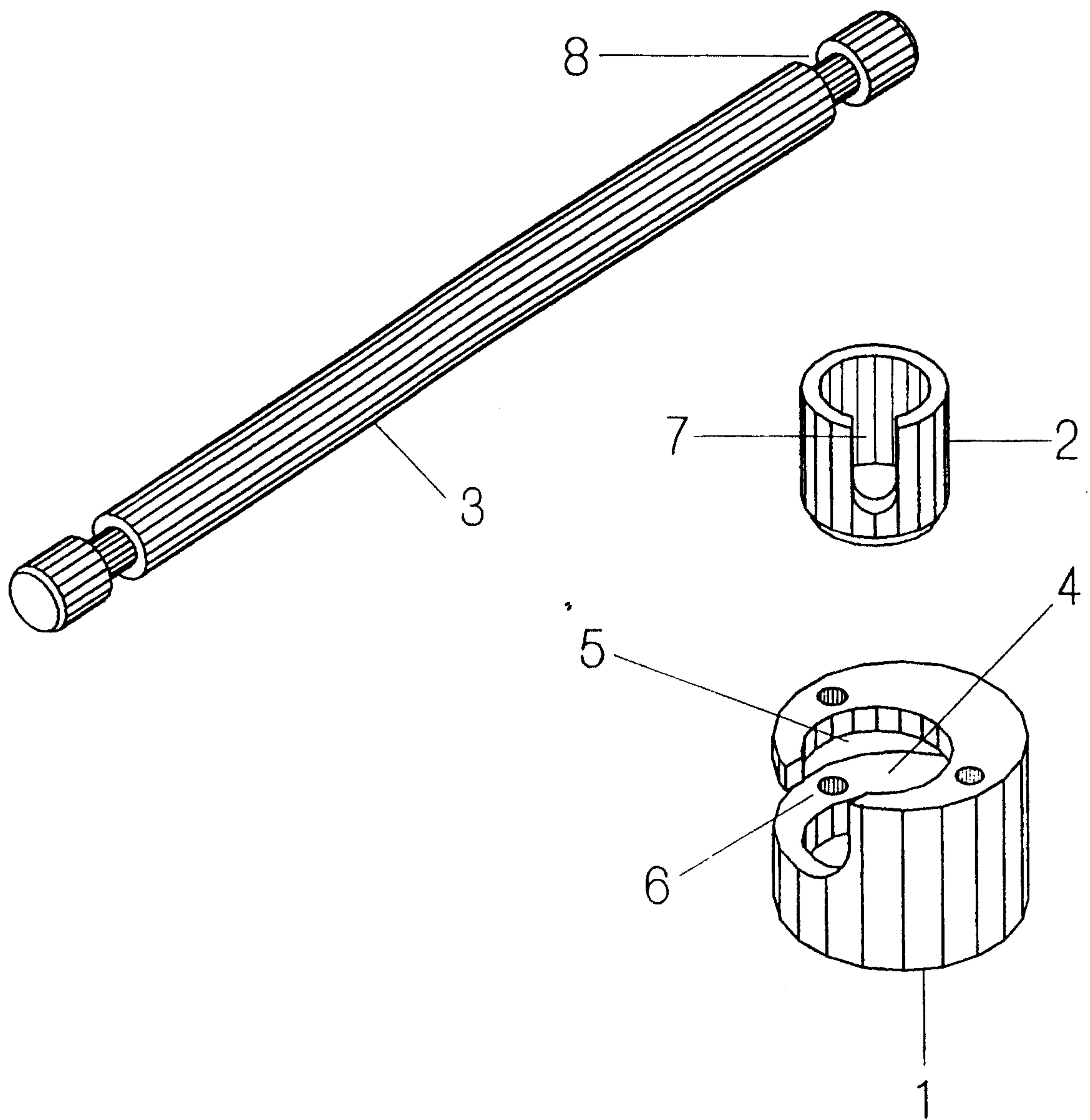

Fig. 1

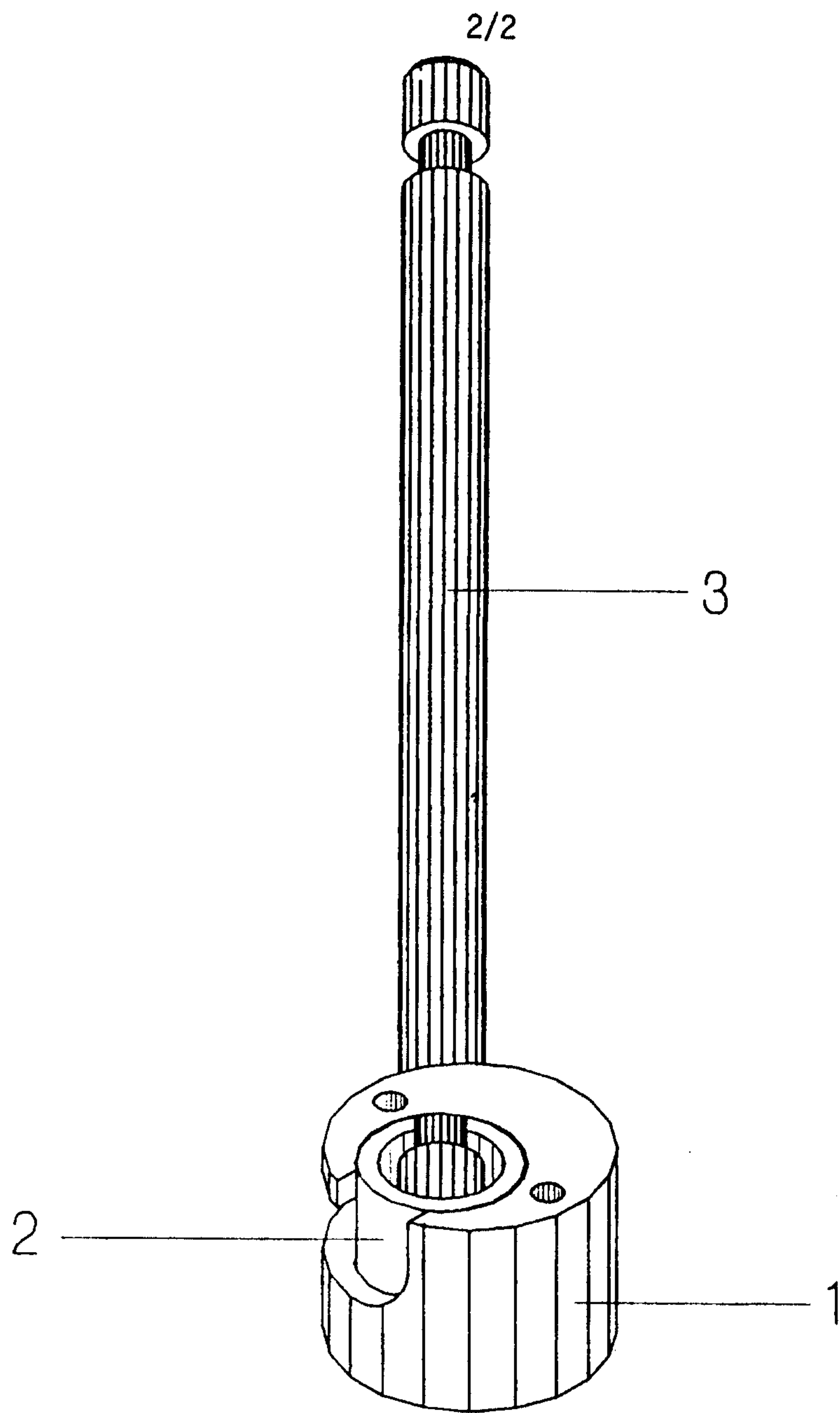

Fig. 2

