

(19) World Intellectual Property Organization
International Bureau



(43) International Publication Date
18 August 2005 (18.08.2005)

PCT

(10) International Publication Number
WO 2005/074563 A2

(51) International Patent Classification: Not classified

(21) International Application Number:
PCT/US2005/002836

(22) International Filing Date: 2 February 2005 (02.02.2005)

(25) Filing Language: English

(26) Publication Language: English

(30) Priority Data:
10/772,010 3 February 2004 (03.02.2004) US

(71) Applicant (for all designated States except US): **RTC INDUSTRIES, INC.** [US/US]; 2800 Golf Road, Rolling Meadows, Illinois 60008 (US).

(72) Inventors; and

(75) Inventors/Applicants (for US only): **SWAFFORD, John W.** [US/US]; 1081 Foxworth Boulevard, Lombard, IL 60148 (US). **LEMBKE, Michael, Alvin** [US/US]; 641 Newport North, Roselle, Illinois 60172 (US).

(74) Agent: **BERGHAMMER, Joseph, J.**; BANNER & WITCOFF, LTD., 10 S. Wacker Drive, Suite 300, Chicago, Illinois 60606-7407 (US).

(81) Designated States (unless otherwise indicated, for every kind of national protection available): AE, AG, AL, AM, AT, AU, AZ, BA, BB, BG, BR, BW, BY, BZ, CA, CH, CN, CO, CR, CU, CZ, DE, DK, DM, DZ, EC, EE, EG, ES, FI, GB, GD, GE, GH, GM, HR, HU, ID, IL, IN, IS, JP, KE, KG, KP, KR, KZ, LC, LK, LR, LS, LT, LU, LV, MA, MD, MG, MK, MN, MW, MX, MZ, NA, NI, NO, NZ, OM, PG, PH, PL, PT, RO, RU, SC, SD, SE, SG, SK, SL, SY, TJ, TM, TN, TR, TT, TZ, UA, UG, US, UZ, VC, VN, YU, ZA, ZM, ZW.

(84) Designated States (unless otherwise indicated, for every kind of regional protection available): ARIPO (BW, GH, GM, KE, LS, MW, MZ, NA, SD, SL, SZ, TZ, UG, ZM, ZW), Eurasian (AM, AZ, BY, KG, KZ, MD, RU, TJ, TM), European (AT, BE, BG, CH, CY, CZ, DE, DK, EE, ES, FI, FR, GB, GR, HU, IE, IS, IT, LT, LU, MC, NL, PL, PT, RO, SE, SI, SK, TR), OAPI (BF, BJ, CF, CG, CI, CM, GA, GN, GQ, GW, ML, MR, NE, SN, TD, TG).

Published:
— without international search report and to be republished upon receipt of that report

[Continued on next page]

(54) Title: SYSTEM FOR INVENTORY MANAGEMENT

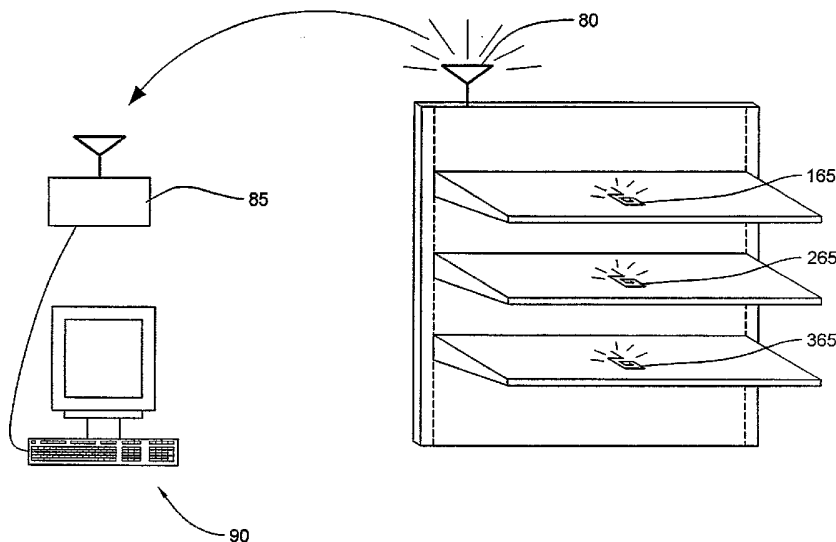

(57) Abstract: The present invention relates to a system for tracking product on a shelf. In an embodiment, an indicia strip (21) is placed on a self coiling sheet (20), and a sensor (30) is configured to read the indicia strip. The data on the indicia strip corresponds to the location of a pusher assembly (15). In an embodiment, a store computer (90) can use the data regarding the location of the pusher assembly (15) to determine the amount of inventory on the shelf. In an embodiment, the store computer (90) can automatically order additional inventory based on the levels of inventory on the shelf. In an embodiment, a deviation from normal customer purchasing habits can be used to prompt security measures so as to reduce the possibility of product theft.

WO 2005/074563 A2



For two-letter codes and other abbreviations, refer to the "Guidance Notes on Codes and Abbreviations" appearing at the beginning of each regular issue of the PCT Gazette.

SYSTEM FOR INVENTORY MANAGEMENT

CROSS REFERENCE TO RELATED APPLICATION

[01] This application claims benefit to U.S. Application Serial No. 10/772,010 filed February 3, 2004.

FIELD OF THE INVENTION

[02] The present invention relates to shelving and product display and a system for aiding in determining the inventory on the shelf in a retail store.

DESCRIPTION OF RELATED ART

[03] A major cost in the operation of retail stores relates to inventory management, which includes the tracking and storing of inventory. A significant portion of this cost relates to product inventory management in the selling area of the store. A considerable portion of this inventory management cost is the periodic counting of product on the store shelves. This counting is necessary to determine the amount of product on the shelf and to help ensure the shelves are fully stocked.

[04] Historically, the counting of inventory on store shelves was done manually and the results were recorded on paper. More recently, however, inventory has been counted manually with the use of a small hand-held computer that can be configured to transmit the entered data to a central computer that compiles data and can be programmed to make decisions regarding the purchase of products for restocking the shelves. These recent advances have helped reduce the cost of inventory management but counting inventory still requires significant manual labor. It would be beneficial to reduce the amount of manual labor required to count the inventory.

[05] Another significant cost relating to inventory management is product theft. Certain items are relatively small but represent a high value to potential thieves who can either resell the items or use them for other illegitimate purposes, as in the case of certain pharmaceutical products. The losses generated by such thefts have a negative impact on the profitability of the retail stores.

- [06] Theft can be the result of both customers and employees actions and has been difficult to eliminate. Attempts to deter and prevent theft have proven to be only partially effective. For instance, in-store cameras often do not observe the theft clearly enough to catch or prosecute the thief. In addition, in-store security personnel are rarely in the correct position to actually observe a thief in action. As a result, theft continues to be a significant problem and cost in the management of inventory. It would be beneficial to provide aid in monitoring for theft.
- [07] Currently, retail stores can track the amount of product sold based on a number of items scanned at the checkout counter. While this ability has proven useful, certain inherent disadvantages result from the use of such a system. One inherent disadvantage is that the scanner only counts the number of products that are legitimately purchased. Therefore, if product is removed from the shelf but not purchased, the store is unable to determine the fact that product has been misplaced or stolen without visual inspection or detection. It would be useful to compare changes in product level on the shelves with the amount of product sold.
- [08] A second inherent disadvantage relates to store-run product promotions. A typical promotion will have a product located at the end of an aisle or in some type of promotional location that increase customer awareness of the product. Usually the product is also placed on the shelf in its traditional location so that customers familiar with the product placement of the store can find the product without undue searching. Therefore, customers can obtain the product being promoted in multiple places and it can be difficult to determine the effectiveness of a particular promotional display, i.e., the effect of a promotional discount offered for the product versus the normal purchasing of the product. It would be beneficial to more accurately determine the effectiveness of in-store promotions.
- [09] Another major cost of inventory management is associated with having to maintain more inventory in the store than is actually needed to meet customer demand. As current systems of inventory do not automatically indicate that a shelf is empty, retail stores tend to rely on output measured through the checkout or, alternatively, through visual inspection to determine if additional product needs to be placed on the shelf. In order to ensure the shelves are stocked with product, often more product than is typically needed

for a given period of time will be placed on the shelf, sometimes in multiple facings on each shelf. The use of multiple facings tends to take up valuable shelf space that could otherwise be allocated towards additional product choices so as to maximize consumer satisfaction. It would be beneficial to reduce the amount of inventory of a particular product in the retail store.

- [10] Methods of minimizing the amount of required shelf space are known. For example, U.S. Patent No. 6,041,720 to Hardy and U.S. Patent No. 4,830,201 to Breslow, which are incorporated by reference in their entirety, teach a system for organizing and displaying items on a shelf through the use of a pusher assembly. While these systems are effective at moving items on a shelf from the back to the front of the shelf, the systems do not provide notification that a shelf is empty. Additionally, if multiple facings are being used for a single product, an uneven usage of the facings can result. If one facing of product is depleted before the other facings of the same product, the shelf will have a gap that provides a less satisfactory appearance to the consumer. This can happen even when ample product is still available. It would be beneficial to indicate to store personnel that shelves require adjustment so as to maintain a more satisfactory product appearance.
- [11] The above deficiencies and drawbacks known in the art are overcome by the present invention.

BRIEF SUMMARY OF THE INVENTION

- [12] An embodiment of the present invention includes a pusher assembly containing a pusher that biases product on a shelf toward the front of the shelf. An indicia strip is provided, where the indicia strip contains data relating to the position of the pusher. A sensor assembly scans the indicia strip and transmits data representative of the position of the pusher. In an embodiment, the data is transmitted to a store computer.
- [13] An aspect of an embodiment of the present invention is that the periodic manual counting of inventory can be avoided because the data transmitted to the store computer allows the determination of inventory levels. In an embodiment, the determination of inventory can be done in real time.

- [14] An aspect of an embodiment of the present invention is that product on the shelf can be changed without the need to change markings provided on the indicia strip. A unique identity code number can be associated with a particular pusher assembly. If desired, the identity number can be associated with a product in the store computer. When it is desired to change the product kept on the shelf, the new product can be associated with the identifying number.
- [15] In an aspect of an embodiment of the present invention, the amount of product sold from a particular location in the retail store can be determined. This information can be used to determine the effectiveness of product placement and promotional displays, particularly when a product can be obtained from various places within the retail store.
- [16] In an aspect of an embodiment of the present invention, a deviation in the typical purchasing habits of the consumer can trigger a silent or audible alarm. The alarm can be used to alert security personnel to the fact that a potential theft has occurred. The location of the incident can also be used to alert a security camera so as to focus the camera in the direction of the potential theft.

BRIEF DESCRIPTION OF THE DRAWINGS

- [17] Several embodiments of the present invention are illustrated by way of example, but are not limited to the accompanying figures in which like reference numerals indicate similar elements and in which:
- [18] Figure 1a illustrates an isometric view of an embodiment of the present invention including a pusher assembly and a sensor assembly.
- [19] Figure 1b illustrates another isometric view of an embodiment of the present invention including a pusher assembly and a sensor assembly
- [20] Figure 2a illustrates a schematic view of an embodiment of the sensor assembly used with the present invention.
- [21] Figure 2b illustrates a schematic view of an alternative embodiment of a sensor assembly used with the present invention.

- [22] Figure 2c illustrates a schematic view of another alternative embodiment of a sensor assembly used with the present invention.
- [23] Figure 3 illustrates a schematic view of an embodiment of the present invention, including an antenna, an access point and a store computer.
- [24] Figure 4 illustrates a schematic view of an embodiment of the present invention, including an access point, a store computer and a security camera.
- [25] Figure 5 illustrates a flow chart demonstrating a method of providing data from the indicia strip to a store computer.
- [26] Figure 6 illustrates a flow chart demonstrating a method of determining the amount of product on the shelf via a query from store computer.
- [27] Figure 7 illustrates a flow chart demonstrating a method of updating the association of particular product with a particular shelf location.
- [28] Figure 8 illustrates a flow chart demonstrating an alternative method of updating the association of a particular product with a particular shelf location.
- [29] Figure 9 illustrates an isometric view of an alternative embodiment of the present invention.
- [30] Figure 10 illustrates a partially exploded view of an alternative embodiment of the present invention.
- [31] Figure 11 illustrate an isometric view of an alternative embodiment of the present invention.
- [32] Figure 12 illustrates an isometric view of another alternative embodiment of the present invention.
- [33] Figure 13 illustrates an isometric view of yet another alternative embodiment of the present invention.

[34] Before the embodiments of the invention are explained in detail, it is to be understood that the invention is not limited in its application to the details of construction and the arrangement of the components set forth in the following description or illustrated in the drawings. The invention is capable of other embodiments and of being practiced or being carried out in various ways. Also, it is to be understood that the phraseology and terminology used herein are for the purpose of description and should not be regarded as limiting. The use of “including” and “comprising” and variations thereof is meant to encompass the items listed thereafter and equivalents thereof as well as additional items and equivalents thereof.

DETAILED DESCRIPTION OF THE INVENTION

[35] The present invention may be used with the shelf and pusher assembly system described in either U.S. Patent No. 6,041,720 to Hardy or U.S. Patent No. 4,830,201 to Breslow. The present invention may also be used with other pusher assemblies and shelf configurations known in the art.

[36] Figure 1*a* illustrates an embodiment of the present invention. A shelf wall 1 is configured to support a shelf 5. The shelf 5 has a front side 6, the front side 6 typically facing the aisle where customers walk when shopping, and a rear side 7. Mounted on the shelf is a pusher assembly 15. As depicted, the pusher assembly 15 includes a biasing mechanism such as a sheet coil spring 20 containing an indicia strip 21. The pusher assembly 15 further includes an integral divider wall 22 and a floor section 23 on one side of the divider wall 22 and a floor section 24 on the other side of the divider wall 22. The sheet coil spring 20 is operatively connected to a pusher 25 and can be used to urge the pusher 25, and the associated product, toward the front side 6 of the shelf 5. The pusher assembly 15 may be modular and can include a divider wall or an additional floor section that fit or mate in place.

[37] As depicted Figure 1*a*, a sensor assembly 30 can be mounted to the underside of the floor 24 over which the pusher 25 travels or to the shelf 5 and is configured to read the indicia strip 21. The sensor assembly 30 can be located at any position along the floor 24 and preferably near the coil spring 20. The indicia strip 21 is configured to provide a pattern that includes a representation associated with the position of the pusher 25. Thus, when

the pusher 25 is moved as far as possible towards the rear side 7 (i.e. the facing is full of product), the sensor assembly 30 can scan a representation on the indicia strip 21 that reflects the pusher 25 being in that position.

- [38] The indicia strip 21 is depicted in Figure 1*a* as a strip mounted on the sheet coil spring 20. The indicia strip 21 can be printed on a paper that can be attached to the coil spring 20, and can be black on white, white on black, or some other colors in a known manner. Alternatively, the indicia strip 21 can be printed or acid etched or laser etched, depending on the sensor assembly 30 used to read the indicia strip 21, in a known manner. Moreover, the indicia strip 21 can be separate from the coil spring 20. In this embodiment, the indicia strip 21 can be mounted alongside or adjacent to the coil spring 20.
- [39] The representations in the pattern contained on the indicia strip 21 can be optically readable or can be read based on other methods, including but not limited to passive variable capacitance, inductance, resistance, or magnetic, or active signal detection.
- [40] Figure 1*b* depicts an alternative embodiment of the invention with the sensor assembly 30 mounted on the front side of the pusher 25, the sensor assembly 30 configured to read the indicia strip 21. In an alternative embodiment, the sensor assembly 30 could be mounted behind the pusher 25. Depending on the location of the coil spring 20, the sensor assembly 30 can be mounted in different places. Preferably, the sensor assembly 30 will be mounted in such a manner so as to avoid direct contact with the product on the shelf so as to minimize damage to the sensor assembly 30.
- [41] In another alternative embodiment, the sensor assembly 30 may be mounted within or on the pusher 25 and configured to read the indicia strip 21. In this embodiment, the indicia strip 21 is not mounted to or part of the coil spring; rather, the indicia strip 21 may be positioned along the top of the floor 24 or along the underside of the floor 24 and is read by the sensor assembly 30. In one aspect of this embodiment, the indicia strip 21 is of the type that may have variable magnetic or capacitive characteristics. The sensor assembly 30 may incorporate an analog oscillator whose frequency is determined by the magnetism or capacitance of the indicia strip 21 at the particular position of the pusher 25. The oscillator can directly modulate the radio frequency signal and send that signal

to a central access point, as discussed below. The central access point can then demodulate the signal and use the signal to determine the position of the pusher 25.

- [42] For a black/white printed indicia strip 21, an optical infrared or visible light LED retro-reflective sensor array can be used. In an embodiment, the indicia strip 21 pattern containing the various representations could be 6 bits wide. In an alternative embodiment, depending on the width of the shelf and the desired precision, the pattern on the indicia strip could be more than 6 bits wide.
- [43] In yet another alternative embodiment, the indicia strip 21 could be less than 6 bits wide. Reducing the number of bits on the indicia strip 21 reduces the precision regarding the position of the pusher 25 but has the advantage of potentially avoiding the need to determine the dimension of the product. An embodiment with a reduced number of bits will be discussed below. The indicia strip will preferably include at least two representations so that the two representations can be used to reflect at least two positions of the pusher.
- [44] Depending on the indicia strip 21 and the sensor assembly 30, the number of measurable positions of the pusher 25 can be varied. For example, a configuration of a 6 bit wide pattern on an indicia strip 21 with a sensor assembly 30 that can scan 6 bits could scan at least 64 representations associated with 64 positions of the pusher 25. The representations in the pattern on the indicia strip 21 can be in many symbologies but a Gray Code provides that only one bit will change in each increment of movement, reducing potential errors. The sensor assembly 30 and the indicia strip 21 can be configured depending on the distance of travel of the pusher 25 and the expected size of the product.
- [45] In an embodiment, the coil spring 20 has a width of about 1 inch and the indicia strip 21 covers approximately 80% of the width of the coil spring 20. One skilled in the art will understand that other widths of the coil spring 20, and other dimensions of the indicia strip 21 are possible with the invention.
- [46] In an embodiment, the number of products on the shelf could be measured by the number of measurable positions of pusher 25. In such an embodiment, the position of the pusher

25 could be used to determine the amount of product on the shelf without the need to manually count the product. In an alternative embodiment, the number of measurable positions could exceed the number of products that can be placed in a facing. In this alternative embodiment, it would be preferable to have the number of measurable positions be an integer multiple of the number of products for ease of calculating the amount of product on the shelf. Increasing the number of measurable positions can therefore improve the ability of the system to precisely calculate the amount of product in a facing. This can become more important when a product package is unusually thin and therefore the incremental movement of the pusher 25 from one code to the next becomes a large percentage of the thickness of each product package that it is pushing.

- [47] Thus, as different products have different dimensions, a configuration of the sensor assembly 30 and indicia strip 21 might be desired with an increased number of measurable positions. For example, a configuration where 256 positions of the pusher 25 are measured might be desirable. Such a configuration could be used to determine the actual number of product on the shelf for a wide variety of product dimensions.
- [48] In an alternative embodiment, the sensor assembly 30 and indicia strip 21 can be configured to provide a decreased number of measurable positions. In an embodiment, four positions of the pusher 25 are measurable. In such a configuration, the shelf would provide information regarding how full the shelf was but would not provide the actual quantity of items on the shelf (assuming that 4 products would not fill the facing). This configuration could be useful in providing an automatic notification that a shelf was running out of product and needed to be restocked without the need to determine the product dimensions.
- [49] Figure 2a depicts a schematic of an embodiment of the sensor assembly 30. A printed circuit board ("PCB") 35 is configured to support a sensor 50, the sensor 50 being compatible with the chosen type of indicia strip 21. A controller 55 is mounted to the PCB 35 and is configured to control the sensor 50 and transmit signals regarding the position of the pusher 25 via an antenna 65. The controller 55 can be configured to actuate the sensor 50 based on an input from the timing device 70. The timing device 70 can include, but is not limited to, a low power interval timer or a real time clock and is configured to provide information relating to the passage of time.

- [50] For a black/white printed indicia strip 21, the sensor 50 can include, but is not limited to, an optical infrared or visible light LED retro-reflective sensor. Preferably, for a 6 bit wide pattern, a linear array of 6 emitters/sensors will be used where one emitter/sensor is aligned with each bit position printed on the indicia strip 21. In an embodiment, the sensor 50 is positioned approximately 0.1 inches from the surface of the printed strip mounted on the indicia strip 21. As each emitter/sensor pair illuminates its bit position, a binary code can be assembled by the controller 55 that corresponds to the representation on the indicia strip 21, the representation associated with a position of the pusher 25.
- [51] Regardless of how the position of the pusher 25 is determined, the controller 55 generates a pusher code that represents the position of the pusher 25. The pusher code can be in digital or analog form and reflects the position of the pusher 25. In addition, the pusher code can be processed data or unprocessed data. Thus, the pusher code can be, but is not limited to, the scanned representation or a controller processed representation. Alternatively, the pusher code can be some other data that reflects the relative position of the pusher 25.
- [52] The controller 55 is powered by a power source 75. The power source 75 can be, but is not limited to, a long life battery, a wired power supply, or a solar panel. As can be appreciated, the type of power supply will have an impact on the functionality of the sensor assembly 30. If the power source 75 is a long life battery, a system configuration designed to utilize less energy will be preferable to avoid the need to change the battery on a frequent basis. If the power source 75 is a wired power source, the sensor 50 can be used more frequently without the need to replenish the power supply and the sensor assembly 30 can even be configured to provide real time information.
- [53] The controller 55 can be manufactured with a unique serial number. In this embodiment, each pusher 25 would be associated with a unique serial number or identity code. Alternatively, each indicia strip 21 can include a unique identity code along with the representation associated with the position of the pusher 25. Encoding the indicia strip 21 with a unique identity code can reduce the complexity of the controller 55 but typically will result in increased complexity of the sensor 50. Regardless, when the information is transmitted from the sensor assembly 30, the information may include an identity code and the pusher code representative of the pusher 25 position. In addition,

information such as time of sending and the status of the circuitry or the status of the power source may also be transmitted.

- [54] Figure 2b illustrates a schematic of an alternative embodiment of a sensor assembly 130. A PCB 135 has a power management circuit 148 configured to minimize use of power. The power management circuit 148 provides power to a sensor 150, a controller 155 and associated memory 156. The memory 156 can be volatile type memory, such as dynamic random access memory, but preferably the memory is non-volatile type memory, such as flash memory, so as to minimize power consumption. As depicted, the power management circuit 148 also provides power to a communication control 157. The power management circuit 148 can also provide power to a timing device 170. As depicted, the power management circuit 148 is powered by a power source 175.
- [55] In this embodiment, an input signal is provided to the controller 155. The input signal can be a signal generated by the timing device 170 or can be from some other source. The controller 155, in response, activates the sensor 150 by sending a signal to the power management circuit 148. The controller 155 receives data from the sensor 150 which is used to form the pusher code representative of the position of the pusher 25. The controller 155 compares the data scanned by the sensor 150 with the previous data scanned by the sensor 150, which is data residing in the memory 156. Depending on the configuration of the system, if the data scanned by the sensor 150 is the same as the previous scanned data, the controller 155 can be configured to wait until the end of the next interval of the timer. If the data scanned by the sensor 150 is different, the controller 155 can then activate the communication control 157 and provide the pusher code to the communication control 157 for transmission. The communication control 157 can then transmit the pusher code for further processing. The terms "transmit" and "transmission," unless otherwise specified, include sending of information over a wire or via a wireless system and can be direct or indirect (i.e. through a network). If the power source 175 is not a wired power supply, however, it is preferable to use a method of communication that consumes relatively little power.
- [56] Figure 2c illustrates a schematic of an alternative embodiment of a sensor assembly 230. A PCB 235 is configured to support a sensor 250 and a controller 255. The controller 255 is powered by a power source 275 and is configured to control the sensor 250 and

has integrated functionality, including but not limited to, time keeping, power management, and communication control. In an alternative embodiment, the controller 255 transmits the data scanned by the sensor 250 without any processing of the data. Thus, in this embodiment the pusher code is the data scanned by the sensor 250. In another alternative embodiment, the sensor and controller can be integrated together.

- [57] Figure 3 illustrates a possible configuration for providing data regarding the position of the pusher 25 to a processing device, such as a store computer 90. As depicted, an access point 80 is configured to transmit information to a central access point 85. The central access point 85 is connected to the store computer 90 and provides the data received from the access point 80 to the store computer 90. The data sent from the access point 80 is received from antenna 165, antenna 265 and antenna 365. The antenna 165 is associated with a particular pusher 25 and sensor assembly 30, typically via the use of a unique serial number that can be associated with a controller. The antenna 265 and the antenna 365 are also associated with different pushers 25 and sensor assemblies 30, each with a unique serial number. Alternatively, one or more antennas could be associated with more than one pushers 25.
- [58] In general, the power required to transmit wireless signals increases as the transmission distance increases. Thus, especially with a battery powered controller, the preferred wireless communication configuration will transmit low powered signals over a short distance. As depicted in Figure 3, the various antennas 165, 265 and 365 transmit a wireless signal to the access point 80, located nearby, thus a low powered transmission is suitable. The access point 80 then re-transmits the signal to the central access point 85 using higher power during the secondary transmission. In this manner, the power source for the various controllers connected to the antenna 165, 265 and 365 can more readily utilize a power source 75 consisting of a long life battery. While the transmission method between access point 80 and central access point 85 is depicted as wireless, the access point 80 and central access point 85 can also communicate over wires.
- [59] In an alternative embodiment, the controller 55 corresponding to each pusher 25 can be hard-wired to an access point 80 so that the controller 55 transmits the data to access point 80 over one or more wires. The access point 80 can then transmit the data to the store computer 90. In another alternative embodiment, the data is transmitted directly

from the sensor assembly 30 to the store computer 90. In this embodiment, the transmission can be either wireless, such as an infrared, ultrasonic or electromagnetic wave transmission, or can be hard-wired. Depending on the method of transmission, it may be desirable to transmit the data from the sensor assembly 30 to the store computer 90 via a network protocol that can compensate for, or minimize, communication errors.

- [60] The use of a wired connection can provide a useful source of power and can reduce the possibility of communication collisions, especially if the signals are directly to the store computer 90. In addition, by providing additional power, the controller 55 can be configured to provide a real time update on the level of product on the shelf or in the store so that more accurate decisions regarding the need to order additional product can be made. This configuration also makes it possible to recognize and send alerts regarding potential theft situations based on the real-time movement of the pusher 25. The real time product information may make it possible to provide a more responsive inventory system so as to lower the amount of inventory in the store and therefore reduce the cost of inventory.
- [61] Wireless systems, on the other hand, provide increased flexibility in installation and can be readily installed in existing shelves without the need to install wires for either power or communication. In addition, the use of a wireless system allows for the gradual installation of an inventory system. For example, items of high value (and therefore suffering from an increased likelihood of being stolen) or items that tend to have significant variations in customer demand can be monitored first.
- [62] In an embodiment, the sensor assemblies 30 may be networked together via a series of wireless access points 80 where each access point 80 accepts transmissions from any sensor assembly 30 in the vicinity of the access point 80. Thus, in an embodiment, there exist a number of wireless access points 80 and the access points 80 are connected via a network, where the network transmits the data to the store computer 90. In an alternative embodiment, each wireless access point 80 transmits the data directly to the store computer 90.
- [63] Naturally, some combination of network and direct transmission is also possible and is considered within the scope of the present invention. For example, a battery powered

sensor assembly 30 could communicate via a low powered wireless transmission to an access point 80, the access point 80 being powered by a wired power supply. The access point would transmit a wireless signal to a central access point 85 that was powered by a wired power supply. The central access point 85 could be connected via a wire to the store computer 90.

- [64] Referring back to Figure 2a, if a timing device 70 comprises a low powered timer, the controller 55 can rest dormant until a signal from the timing device 70 indicates it is time to send an update regarding the position of the pusher 25. An example of a low powered timer includes a low powered, low cost interval timer. Low powered, low cost interval timers may not be highly accurate and therefore multiple pusher devices in a store will likely randomize their transmission times so as to reduce transmission collisions. The period of data transmission typically will be on the order of a few milliseconds, and therefore, it is unlikely that signals from different controllers will be sent at the same time. This likelihood can be further decreased if the controllers are not all started at the same time. If the transmissions only occur a few times per day (i.e. to provide periodic updates on the amount of product on the shelf), the likelihood of communication collisions is further reduced. In addition, the decreased frequency of transmission and the short transmission period helps reduce the amount of power consumed.
- [65] In an alternative embodiment, the sensor 50 continuously monitors the indicia strip 21. When a product is removed from the shelf, the pusher 25 will move and the sensor 50 can scan a new representation on the indicia strip 21 corresponding to the new position of the pusher 25. The controller 55 can then send a transmission including the new position of the pusher 25 to the store computer 90 (i.e. the controller 55 can send a new pusher code). In this alternative embodiment, the store computer 90 can monitor the amount of product on the shelf in real time.
- [66] As depicted in Figure 3, the transmission of signals, from the antenna 165 to the store computer 90 for example, is a one-way transmission. In an alternative embodiment, the system may be set up to handle two-way transmission of signals between the sensor assembly 30 and the store computer 90. In a two-way wireless system, additional hardware such as a receiver is included in the sensor assembly 30. The two-way system allows for bi-directional transfer of information.

- [67] For example, the store computer 90 could query a particular controller 55 about the position of the associated pusher 25. The controller 55 could activate the sensor 50 in response to the query and determine a pusher code reflecting the position of the pusher 25. The controller 55 could then transmit the pusher code along with the identity code of the controller 55 to the store computer 90. Based on the pusher code, the store computer 90 could determine the inventory level of a product. To avoid activating the wrong controller 55, the store computer 90 could include the identifying code in the transmission. The store computer 90 may store, access, and perform functions with the identifying codes of all or a subset of the controllers or pusher systems in the store.
- [68] In an embodiment, all the controllers 55 associated with products purchased from the same vendor could be queried just before the order to the respective vendor was placed. The order to that vendor could then be updated with the latest product inventory information. In this manner, the order placed to the vendor could be made more accurate without the need for laborious counting of products on the shelf.
- [69] Some vendors are responsible for stocking the shelves in a retail store instead of the store personnel. In a situation where a vendor was responsible for stocking the shelves, an embodiment of the present invention could provide the vendor with updates in response to queries from the vendor's computer. In an embodiment, the vendor could track the amount of product available on the shelves as frequently as desired, even in real time.
- [70] For example, a vendor could send a query to a controller 55 via a wide area network ("WAN"). The controller 55 could determine the position of the pusher 25 and transmit a signal back to the vendor via the WAN. In an alternative embodiment, the vendor could communicate with the store computer 90 to obtain information regarding the inventory level of products on the shelf.
- [71] In an embodiment, the vendor could control the manufacturing process of the product in response to inventory levels on the shelves. As can be appreciated, the vendor would have an increasingly effective inventory system if multiple stores were networked to the vendor's computer so that the aggregate amount of product on all the store shelves could be determined. If the vendor was only connected to a single store, the information, while

less indicative of the total inventory, could provide valuable details regarding patterns of behavior of the consumers.

- [72] Figure 4 illustrates an embodiment of the present invention that includes the use of a security camera 195. As depicted, an access point 180 receives a signal from a controller 155 indicating that pusher 25, not shown, has moved. The access point 180 transmits the signal to a central access point 185 that is connected to a store computer 190. The store computer 190 determines that the rate of change in product level of the product associated with the controller 155 is indicative of a potential theft. The store computer 190 then transmits a signal, either wired, or wirelessly, to an antenna 196, which is mounted to the security camera 195. The signal instructs the security camera 195 to monitor a position associated with the location of the controller 155. As can be appreciated, security personnel can sometimes provide a more nuanced response, thus it is advantageous to notify security personnel. Therefore, the store computer 190 can also notify security personnel to monitor the area by displaying a warning on the store computer screen or by transmitting a signal to a security computer or by activating an audible tone or flashing light in the vicinity of the potential theft or by other known methods of notification such as a signal to the pager or beeper carried by the security personnel.
- [73] Information from the security camera could be sent to a television or other visual display device that is located near the location where the potential theft is occurring. The visual display device could display an image of the potential thief such that the potential thief could appreciate the fact that the thief was being watched.
- [74] As can be appreciated, the controller 155 preferably monitors the position of pusher 25 on a frequent or even real time basis so as to provide a more timely response. If a power source 75 consisting of a long life battery is utilized, it may be beneficial to utilize a controller that can determine a potential theft situation without the need to transmit data to the store computer 190. In such an embodiment, the controller can be configured to transmit data to provide inventory level updates and also to provide security notifications.

- [75] As can be appreciated, the position of the potential theft relative to the security camera 195 would be beneficial to provide an instruction to the security camera 195 to focus on a particular position. This positional information could be generated by a number of methods, including providing the store computer 190 with the security camera coordinate system for the security camera 195. The position of the controller 155 relative to the security camera 195 could be determined during setup and during a potential theft situation; the position of the controller 155 could be used to direct the focus of the security camera 195. Alternatively, the security camera 195 could be configured to focus in several positions, such as three points along an aisle, and the store computer 190 could indicate which position was the most appropriate for the particular situation. The described methods are illustrative because of the numerous methods of controlling the security camera 195 that exist.
- [76] In an embodiment with a two-way transmission between the store computer 190 and the controller 155, the store computer 190 could signal to the controller 155 to activate a device capable of providing an audible warning tone.
- [77] In another embodiment, the controller 155 could determine that a potential theft had occurred and could provide a notification, including the sounding of an audible warning tone. In addition, the controller 155 could transmit a signal to the store computer 190. In this alternative embodiment, the sensor assembly 30 would preferably include a timing device 70 so as to allow the controller 155 to more readily determine whether the rate of movement of pusher 25 exceeds a preset level.
- [78] In another embodiment, a two-tiered response could be implemented. If the change in position of the pusher 25 was greater than normal, a signal could be transmitted to the security camera 195. In addition, an inaudible notification could be provided directly to security personnel. If the positional change of the pusher 25 more clearly indicated a potential theft, an audible alarm and flashing lights could also be activated. Thus, the response could be configured to more carefully match the situation.
- [79] Figure 5 illustrates an embodiment of a method for determining the amount of a particular product available in a facing on a shelf. In this embodiment, the sensor assembly 30 uses a timing device 70 consisting of a low powered interval timer. The

controller 55 is initially in a dormant state and only the timing device 70 is running. In step 400, the timing device 70 provides a signal to the controller 55 that the time interval is complete. In step 405 the controller 55, in response to the signal from the timing device 70, becomes activated and the controller 55 then activates the sensor 50.

- [80] In step 410, the sensor 50 scans the representation contained in the pattern on the indicia strip 21 so that the controller 55 can generate the pusher code representative of the position of the pusher 25. In step 415, the controller 55 generates the pusher code in response to the pattern scanned by the sensor 50. In step 420, the controller 55 transmits a signal that can include the unique serial number of the controller 55 and the pusher code, to the store computer 90.
- [81] Next, in step 430, the store computer 90 receives the data from the controller 55. In an embodiment, the transfer of data from the controller 55 to the store computer 90 is direct. In another embodiment, the controller 55 transmits data to the store computer 90 indirectly through an access point or a network.
- [82] Then, in step 440, the store computer 90 calculates the amount of product on the shelf based on the position of the pusher 25. The store computer 90 also updates the inventory list at this point. In an embodiment where multiple facings have the same product, the total amount of product on all of the facings that have that product can be calculated. In an embodiment, the calculation of product in a facing can be accomplished through the use of a database of products and the relevant dimensions of a product, and the position of the pusher. In another embodiment, the number of products placed in the facing can be provided during setup of the controller 55 for that product. The position of the pusher 25 and the number of products corresponding to that position of the pusher 25 can be used to calculate the quantity of remaining products based on a later position of the pusher 25 through the use of well known extrapolation techniques.
- [83] In another embodiment, the position of the pusher 25 can be one of four positions representing $X > 3/4$, $3/4 \geq X > 1/2$, $1/2 \geq X > 1/4$, and $X \leq 1/4$. This latter embodiment provides less precise information but also requires less computation effort to provide the approximate inventory level. In addition, this embodiment can be used to manage inventory without the need to determine and track the dimension of the product. In an

embodiment, the amount product on the shelf can be roughly determined based the number of facings containing the product and whether the pusher 25 for each facing is in a position representative of a full, mostly full, low or almost empty facing.

- [84] In step 450, the store computer 90 determines whether any action is required. In an embodiment, a potential theft, a decrease in the inventory below a pre-set level or the emptying of a facing of product while ample product still remains on the shelf in other facings would indicate that some action was required. For example, the store computer 90 could determine that, based on historical usage and the average delivery time and the cost per delivery, the current level of inventory was low. In an alternative embodiment, the minimum inventory level could be preset and once the inventory level drops below a preset level, the store computer 90 could determine that the product level was low.
- [85] In step 460, the store computer 90 would determine if a potential theft was taking place. In an embodiment, the store computer 90 could compare the current level of inventory, based on the position of the pusher 25, to the previous level of inventory. If the rate of change in inventory level exceeded a preset level, the store computer 90 would determine that a potential theft was taking place. In step 465, the store computer 90 would notify security. The notification could include a page to security or a signal to a security camera 195 to focus in a particular direction.
- [86] Next, in step 470, the store computer 90 would determine if the existing order needed to be modified. The store computer 90 could compare the current product requirement to the current order. If the store computer 90 determined that an amount of product ordered was insufficient, the store computer 90 would proceed to step 475. In step 475, the store computer 90 would update the current inventory order so that the inventory order matched the current product requirements.
- [87] Next, in step 480, the store computer 90 would determine if a facing on a shelf was empty. If there was an empty facing, the store computer 90 would then notify the store management that there was an undesirable empty facing in step 485. The store management could then decide the appropriate action to take depending on the type of product and the availability of substitute goods. If the facing was not empty, the store computer 90 would wait until the next product update.

- [88] Figure 6 depicts an embodiment of a method for determining the amount of inventory on the shelf in a two-way system. In step 510, the store computer 90 sends a query to a sensor assembly 30. The sensor assembly 30 contains a controller 55 that is identified by a unique serial number or identifying code.
- [89] In step 520, the sensor assembly 30 receives the query from the store computer 90. In response to the query, the controller 55 activates the sensor 50 and prepares to receive data reflecting the position of the pusher 25. In step 530, the sensor 50 scans the indicia strip 21 and the controller 55 generates a pusher code representative of the position of the pusher 25.
- [90] In step 540, the sensor assembly 30 transmits the pusher code representative of the position of the pusher 25 along with the unique serial number of the controller 55 to the store computer 90.
- [91] Next, the store computer 90 receives this transmission in step 550. This transmission can be sent directly from the sensor assembly 30 to the store computer 90 or, preferably, it can be indirectly through a network. The transmission can be sent in a wireless manner, over wires, or some combination of a wireless and wired transmission.
- [92] Then, in step 560, the store computer 90 determines the level of inventory on the shelf. In an embodiment, the determination can be based on the product dimension and the position of the pusher 25. In an alternative embodiment, the determination can be based solely on the position of the pusher 25.
- [93] Figure 7 depicts an embodiment of a method for setting up a controller for a particular product. In step 610, the product can be placed on the shelf in the appropriate facing. Alternatively, step 610 can be skipped and the set-up can start with step 620.
- [94] In step 620, a set-up button on a hand-held device is pressed. The hand-held device is configured to transmit a signal to a store computer 90 indicating that the user of the hand-held device is about to associate a product with a serial number or identifying code of a controller 55. Preferably, the transmission of signals between the hand-held device and the store computer 90 is done in a wireless manner. In an embodiment, the store

computer 90 provides feedback to the user indicating that the store computer 90 is ready to proceed. In an alternative embodiment, no feedback is provided.

- [95] Next, in step 630, the UPC code of the product is scanned and transmitted to the store computer 90. Then, in step 640, the store computer 90 looks up the product dimension based on the UPC code. If the UPC code does not have a listed dimension, the store computer 90 checks if the user can input the needed dimension in step 642. If the user cannot, the setup is terminated and the user can try to setup a new product. If the user can determine the dimension, the user enters the dimension in step 644.
- [96] Next, in step 646, a dimension is associated with the UPC code. Then, in step 650 the store computer 90 sends a signal to the hand-held device to indicate that the user should proceed with the setup.
- [97] Next, in step 660 the user activates the controller 55 with the hand-held device. In an embodiment, an optical setup sensor is mounted on the pusher assembly and is connected to the controller 55. Preferably, the setup sensor is recessed in the pusher 25 but could be mounted in other locations such as on the top or the side of the pusher 25. The hand-held device will be configured to transmit a signal to the setup sensor. The act of transmitting the setup signal to the setup sensor will cause the controller 55 to awake from a dormant state.
- [98] Then in step 670, the controller 55, in response to the setup signal, will send data indicating that the controller 55 is being setup to the store computer 90. The data will include the unique serial number of the controller 55. The data may also include a generic setup code or a setup code corresponding to the hand-held scanner and can include a pusher code representative of the position of the pusher 25. In the event that multiple hand-held devices are being utilized at the same time, it may be beneficial to provide a setup code associated with a particular hand-held device.
- [99] Next, in step 680, the store computer 90 will receive the data from the controller 55. If the data includes the pusher code, the store computer 90 can calculate the amount of product in the facing at this time. In step 685, the store computer 90 sends a signal to the hand-held device indicating that the controller 55 has been setup and associated with the

UPC code of a particular product. In addition, if the position of the pusher 25 was originally included, the store computer 90 can also provide a calculation of the current quantity of product in the facing that was just set up. In addition, the store computer 90 requests that the user verify that the setup information is correct.

- [100] Finally, in step 690, the user indicates the information is correct. Upon verification, the setup for the controller 55 is complete. To change the product associated with the controller 55, the process can be repeated.
- [101] Figure 8 illustrates an alternative method of associating a controller with a product. In step 710, a hand-held device is activated to indicate that the user is about to setup controller 55. The activation includes the transmission of a signal to a store computer 90.
- [102] In step 720, the hand-held device is used to scan the UPC code of the product and transmit the information to the store computer 90. Next, in step 730, the store computer 90 looks to see if a product dimension is listed for that scanned UPC code. In the event that no dimension is associated with the UPC code, the computer, in step 732, transmits a signal to the hand-held device requesting the user to input the appropriate product dimension.
- [103] If the user does not know the product dimension or cannot measure the dimension, the user can cancel the setup and start over with a new product in step 734.
- [104] If the user does know the dimension or is able to measure the dimension, the user then enters the dimension and transmits the information to the store computer 90 in step 736. After the product dimension is determined, in step 740, the store computer 90 sends a signal to the hand held device indicating that the user should proceed.
- [105] Next, in step 750, the user scans the serial number of the controller 55. Preferably, the serial number of the controller 55 is printed in a black/white code on a sticker mounted to the sensor assembly 30. After scanning the serial number, the hand held device transmits the serial number to the store computer 90.

- [106] Then, in step 760, the store computer 90 associates the UPC code of the product with the serial number of the controller 55. The store computer 90 then signals the hand held device that the setup for the device is complete. To avoid potential communication problems during setup, all communications between the hand-held device and the store computer 90 can include a code representing the hand-held device.
- [107] In an alternative embodiment, the method of associating a product with a controller 55 could be done without sending a signal to the store computer 90. In this embodiment, the data would be uploaded from the hand-held device once the user had associated the various controllers with the various products.
- [108] As can be appreciated, numerous methods of product association with a controller 55 are possible, thus the above methods are illustrative.
- [109] A system for determining the location of the pusher with an indicia strip and sensor has been described. Numerous additional methods exist for measuring the distance between the front or rear of a shelf and the pusher or the final product in a facing of products. Based on this distance, and understanding the dimension of the products in the facing, a simple calculation can be performed to determine the number of products in the facing. This calculation can be performed by a microprocessor, store computer, controller or some other processing device which has received the information regarding the distance between the shelf front and the last product in a facing. Moreover, the pusher assembly has been described to include a spring. However, some other biasing method, such as gravity or magnetism, would also work to move the pusher and the product forward.
- [110] In an embodiment of the present invention, as illustrated in Figure 9, the use of transmitted light or other signal, such as a radio frequency signal, that is passed between a position near the back of the facing of products and a stationary position can be used to measure the distance between the front of the shelf and the pusher. In one embodiment, a transmitter 700 or 702 is incorporated into a pusher 725. The transmitter generates a light or other signal that can be transmitted on command, periodically or continuously. A light emitting diode (LED), radio frequency or ultrasonic generator or other signal generation device can be used to generate the light or signal.

- [111] A corresponding receiver is incorporated into a location that is stationary in relation to the pusher 725. The receiver 712 can be incorporated into a front rail or another location at or near the front of the shelf, a receiver 730 can be incorporated into a rear rail or other location at or near the rear of the shelf, it also can be incorporated into the floor of the shelf, the track of the pusher, the roof of the shelf or the divider wall. The receiver detects the signal that is sent from the transmitter. For example, a LED may radiate light having a particular intensity. A phototransistor acting as a receiver detects the light signals being emitted from the LED. The sensitivity of the phototransistor and the intensity of the LED may be adjusted by the microprocessor in order to adjust the overall sensitivity of the optical components. In an embodiment, the adjustment can be done remotely. Thus, the transmitter can communicate in a wireless fashion with the receiver through RF, IR or other known means such as magnetic fields, electrical fields, sound waves and the like.
- [112] The transmitter and receiver may be in communication with a controller that tracks the time of sending and receiving. This data can be provided to a processing device such as a microprocessor or a store computer, thus in this embodiment the pusher code would include the time interval between sending and receiving. Information regarding the time at which the signal was sent and the time at which it was received may be utilized by a processing device to determine the time between the transmission and the receipt of the signal. Based on this length of time, the processing device can calculate the distance between the transmitter and the receiver. Knowing the dimensions of the shelf, the pusher system and the components thereof, this distance can then be translated into the distance between the front side 6 of the shelf and the face of the pusher 25 that is biased against the back of the facing of products. Such a translation is well known and within the knowledge of one of ordinary skill. If the relevant dimension of the products in the facing is known, the processing device can then calculate the number of products in the facing based on the known dimension of the products.
- [113] In an alternative embodiment, the transmitter and the receiver switch locations. The transmitter can be placed at or near the front or the rear of the shelf or other relatively stationary position and the receiver can be placed on or near the pusher. In an alternative embodiment, the transmitter and the receiver can be incorporated into the same device

which merely bounces a signal off a stationary position. For example, a reflector can be placed on the pusher and a transmitter/receiver using a laser, or some other light source, can determine the distance between the reflector and the transmitter/receiver based on the time of travel. Examples of possible transmitter/receivers include, but are not limited to, optical displacement measurement sensors and reflective laser sensors. As can be appreciated, if a transmitter and a receiver are used to determine distance, it is preferable that the location of either the part that is stationary be located near the front side or the rear side of the shelf so as to make the distance calculation simpler and to avoid problems with symmetric distances on both sides of the stationary unit mounted to the shelf. For example, mounting a transmitter halfway between the front and rear of the shelf would make determining the location of the pusher more complicated because there would be two possible locations for a given distance.

- [114] In an embodiment, depicted in Figure 9, a transmitter (700, 702) is incorporated into a pusher 725. The transmitter is a light emitting diode and is located at any location on the pusher 725 that allows the transmitter to function. The transmitter can be located at the top of the pusher 725 at 700 or at the base of the pusher 725 at 702 or at other locations on the pusher 725.
- [115] A receiver is located at a position that is fixed in relation to the movement of the pusher 725. The receiver may be a phototransistor and can be located on the front of the shelf 705, such as receiver 710 or on a front rail 708 connected to the front of the shelf, such as receiver 712. The receiver can further be located on the floor of the shelf at any number of positions as represented by 714, on the floor of the pusher track at 716 or at a location above the shelf 705 such as on another shelf (not shown) mounted above the shelf 705. The receiver can be located on the divider wall at 720 or 722 or other location on the divider wall. The receiver also can be located near the rear side 707 at 730 or at 732. Preferably, the receiver will be mounted near the either front side 706 or the rear side 707 so as to make distance calculation simpler.
- [116] The receiver and the transmitter can also switch locations. The pusher can incorporate a receiver, and a transmitter can be incorporated at any of the locations 710 – 732 as well as in any other location that is fixed in relation to the movement of the pusher.

Preferably, however, the location of the transmitter will be near either the front side 706 or the rear side 707 so as to make calculation of distance simpler.

- [117] In an embodiment, the transmitter is located at 700 and the receiver is located at 710. When the pusher moves backward or forward on the shelf, the transmitter 700, mounted on the pusher 725, moves with the pusher 725. When the pusher 725 is located near the back of the shelf, a signal will take a certain amount of time to travel from the transmitter 700 to the receiver 710. When the pusher 725 is located closer to the front of the shelf, a signal will take less time to travel from the transmitter 700 to the receiver 710. Data regarding the transmission and receipt of the signal (i.e. the pusher code) is sent to a microprocessor or other processing device. The processing device determines the amount of time it takes the signal to travel from the transmitter to the receiver. Knowing the signal travel speed, the processing device determines the distance between the transmitter and the receiver.
- [118] With an understanding of the location of the transmitter in relation to the products and an understanding of the location of the receiver in relation to the front or back of the shelf, the processing device will be able to determine the distance between the pusher and the front of the shelf. Using the dimension of the products, the processing device can then determine the number of products in the facing. The light emitting diode or other transmitter can be set to function periodically, continuously or on command from a remote location.
- [119] Alternatively, the processing device may control both the LED and phototransistor. The processing device may record a time T1 in which the microprocessor issues a command to generate a pulse from the LED and a time T2 in which the light signal is detected by the phototransistor. Both of these times T1 and T2 may be stored in memory and used to determine the number of product in the facing, using the above described relationships.
- [120] In an alternative sensing environment, a capacitive proximity sensor may be utilized to measure the distance between the front of the shelf and the pusher or the final product in a facing of products. The capacitive proximity sensor detects the pusher which acts as a target for the capacitive proximity sensor. The capacitive proximity sensor generates an electrostatic field which is directed at the target. As the distance of the pusher changes

with respect to the location of the capacitive proximity sensor, the capacitive proximity sensor reacts to the changes in capacitance caused by the movement of the pusher in relation to the sensor.

- [121] Additional sensing environments may also include the use of magnetic proximity sensor or an inductive proximity sensor. In both sensing environments, the proximity sensors may be utilized to measure the distance between the front of the shelf and the pusher or the final product in a facing of product.
- [122] An inductive proximity sensor is useful in detection of metal targets as the inductive proximity sensor uses an induced field to sense the target object. In an embodiment with an inductive proximity sensor, the proximity of a pusher in relation to the inductive proximity sensor can be detected as the distance of the pusher changes with respect to the location of the inductive proximity sensor. Similarly, a magnetic proximity sensor based on the Hall Effect principle may also be utilized to sense the location of the pusher.
- [123] In an embodiment, a proximity sensor could be mounted near the rear side 707, the proximity sensor configured to sense the distance to the pusher 25. A processing device, such as the store computer or microprocessor, could determine the distance between the pusher 725 and the front side 706 and use that distance to determine how much product was left on the shelf.
- [124] In an alternative embodiment, a Radio Frequency Identifying Transponder ("RFIT") having a unique identity code is mounted to the pusher 725. A sensor assembly including a transmitter/receiver can be mounted on the rear side 707 of the shelf 705. The transmitter/receiver, when activated, transmits an activation signal that activates the RFIT. The RFIT, upon activation, transmits a responsive signal that includes the unique identifying code. The transmitter/receiver receives the responsive signal from the RFIT. The sensor assembly is equipped with a timing device and measures the time between the initial transmission of the signal from the transmitter/receiver until the receipt of the responsive signal from the RFIT. In an embodiment, a controller can initiate the transmission of the signal and record the receipt of the responsive signal into memory. The controller is also equipped with a timing device to measure the delay. The delay in time can be used to calculate the distance between the transmitter/receiver and the RFIT.

In an embodiment, the controller can calculate the distance and provide a pusher code that includes the distance. Alternatively, the pusher code will include data regarding the delay and the pusher code will be forwarded to a processing device for distance calculation. As discussed above, the distance between the pusher 25 and the transmitter/receiver can be used to calculate the amount of product remaining in the shelf.

- [125] An advantage of using an RFIT in combination with a transmitter/receiver is that it can be easily retro-fitted to existing systems. As the RFIT does not require internal power, this embodiment eliminates the need to provide a powered device on the pusher 725. The transmitter/receiver, however, is powered. Preferably, the transmitter/receiver transmits a focused or low powered signal so that only the RFIT associated with the transmitter/receiver is activated. Alternatively, the transmitter/receiver ignores responsive signals from RFIT's that do not include the proper unique identifying code.
- [126] In another alternative embodiment, a low powered, one-chip radar sensor may be used to determine the distance between the radar sensor and the pusher 725. Preferably the radar sensor may be mounted near the rear side 707 so as to make distance determinations less complex.
- [127] In an alternative embodiment of the present invention, a device for measuring the tension of the spring used for pushing the products can be used. The tension on the spring will, at least in part, be dependent upon the number of products in front of the pusher. As more products are placed in front of the pusher, the spring either further compresses or expands. In the case of a coil spring, as more products are placed in front of the pusher, the two ends of the spring move further apart and the spring further uncoils. As the spring uncoils, the amount of tension or pressure within the remaining coil of the spring increases. By measuring the tension of the spring, the length of the spring that is uncoiled can be determined.
- [128] The spring tension measuring device can incorporate a processing device or can transmit the information it measures to a microprocessor or other processing device. With a previous understanding of how the tension on the spring relates to the length of the spring, the processing device can determine the amount or length of spring that is

uncoiled. For example, if the coil spring has a fixed spring constant, "k", then the formula $F = -kX$ can be used to calculate the length of spring that is uncoiled. This information can be used to determine the distance between the front of the shelf and the pusher. Understanding the dimensions of the products, the computing device can then determine the number of products in a facing.

- [129] A spring tension measuring device may include a force measuring unit that includes, but is not limited to, strain gauges, tensiometers, torque transducers or some other force measuring device to determine the tension exerted on the coil spring. The force measuring unit is preferably connected to a controller, where the controller is configured to convert the data from the force measuring unit into a force value. The controller could then transmit the force value to a processing device. In this embodiment, the pusher code would include a force value. Numerous other methods of measuring spring tension will be apparent to one of skill in the art and are within the scope of the invention.
- [130] In an alternative embodiment of the present invention, the number of products remaining in a particular facing is determined in part through the use of one or more transmitter(s) and receiver(s) placed on opposite lateral sides of the products. In one embodiment the transmitters or receivers may be placed on divider walls that separate facings of products. In one embodiment, a series of transmitters is incorporated into or onto the base of a divider wall. A series of receivers is incorporated into or onto the other side of the divider wall. In this manner, when products are on a shelf, those products that are being pushed are between the transmitters on one divider wall and the receivers on another divider wall.
- [131] Periodically, when prompted, or continuously, the transmitter sends a signal. If there is no product between the transmitter and the receiver, the receiver will receive the signal. If there is a product between the transmitter and the receiver, the product will block the signal, and the signal will not be received by the receiver.
- [132] A microprocessor receives the information regarding whether or not the various receivers received a signal. Based on this information, the microprocessor can determine the approximate distance between the front of the facing and the last product in the facing. With an understanding of the dimension of the products, the information regarding

receipt and non-receipt of signals can be translated into an understanding of the approximate number of products in the particular facing. In an embodiment, one transmitter and one receiver is used to indicate that a particular shelf is running low on the associated product. In this embodiment, the location of the transmitter/receiver is preferably closer to the front side 706 than the rear side 707. Preferably a controller with a unique identifying code is associated with the transmitter and receiver so that the unique identifying code can be associated with the product.

- [133] The transmitter and the receiver can be incorporated into the same device which attempts to bounce a signal off a predetermined target affixed to a particular location. If the signal bounces as expected, it indicates that there is no product between the transmitter and the target location. If the signal does not bounce as expected, a product exists between the transmitter and the target location.
- [134] Figure 10 depicts a partially exploded view of an alternative embodiment of a shelf and pusher assembly, the shelf having divider walls. As depicted in Figure 10, several transmitters 750 are placed on the left side of the divider wall toward the bottom. The transmitters also can be placed higher on the divider wall as shown at 752. Corresponding receivers 760 are placed on the right side of the divider wall toward the bottom. These receivers also can be placed higher on the divider wall as shown at 762. The receivers and the transmitters are positioned such that an unobstructed signal can be sent from a transmitter and received by a corresponding receiver. When product, such as product P, is positioned in front of a pusher, it can obstruct the signal sent from the transmitter. As shown in Figure 10, product P (shown in dashed lines) will prevent the signal from reaching the receiver 760 nearest the front side 6 of the shelf. The receivers that are positioned further back than product P will receive the signals sent to them. A microprocessor receives the information regarding whether each of the receivers 760 received signals. Based on this information, the microprocessor can determine the distance between the front of the shelf and the last product in a particular facing. With an understanding of the width of each product, the microprocessor can determine the number of products in a particular facing.
- [135] In one embodiment of the present invention, the pusher contacts a variety of sensing devices as it moves backward or forward on a shelf. Sensing devices are placed on a

surface below, above, or on the sides of a pusher. These sensing devices include devices that are mechanical, electrical and eletromechanical, optical and magnetic, and can include spring loaded latches, electrical contacts, light emitting diodes or metal wires or other sensors such as linear position sensors.

- [136] As the pusher moves backward or forward on a shelf, it interacts with the sensing devices. The pusher may interact with the devices through the mechanical contact of the pusher and the devices. The pusher may also be equipped with a separate sensing device that interacts with the stationary sensing devices as the pusher moves backward or forward.
- [137] Information regarding the interaction between the pusher and the sensing devices (i.e. the pusher code) is sent to a processing device. Based on the determination of the devices with which the pusher interacted, the processing device can determine the approximate position of the pusher in relation to the front of the shelf. With an understanding of product data, such as the dimension of the product, a processing device can then determine the approximate number of products that are in the particular facing related to the pusher and the sensing devices.
- [138] In an embodiment, as depicted in Figure 11, sensing devices 810, 811 and 812 are incorporated into the base of the track on which the products rest. When products are resting directly over the switches, the sensing devices are closed. As products are removed and the pusher 825 travels forward, the sensing devices that are to the rear of the pusher 825 are released and open. A controller determines which sensing devices are open or closed. Based on this information, a processing device can determine the approximate distance between the pusher 825 and the front side 806 of the shelf. Knowing the dimension of the products, the processing device can determine the number of products in a particular facing.
- [139] In an alternative embodiment, as depicted in Figure 12, sensing devices 814, 815, 816, 817, and 818 are placed on the pusher track 802. A separate contact (not shown) is placed on the bottom of the pusher 825. The contact on the pusher 825 is configured such that when the contact on the pusher 825 is adjacent to a sensing device mounted on the pusher track 802, the sensing device on the pusher track 802 is activated. When the

sensing device is activated, a signal is sent to a processing device, the signal providing information as to which sensing devices has been activated. Based on this information, the processing device can determine the approximate distance of the pusher from the front of the shelf. Knowing additional data about the products, such as the product dimensions, the processing device can determine the number of products in a particular facing.

- [140] For example, while contact 816 is activated, the processing device can determine that the amount product is equal to the amount of product that can fit in the space between the contact 816 and the front side 806 of the shelf 801. In the event that the contact 816 is activated and then deactivated, the processing device can determine that the pusher 825 is between contacts 815 and 817. This, therefore, provides an approximate position of the pusher 825 and the approximate position can be used to determine the approximate quantity of product remaining on the shelf. In an embodiment, the contacts can be spaced closer together near the front side 806 of the shelf 801 so that more accurate measurements can be taken as the amount of product on the shelf decreases. Alternatively, enough contacts can be used to provide a relatively precise location of the pusher 825.
- [141] In an alternative embodiment, as depicted in Figure 13, the contacts 819, 820, 821 and 822 can be mounted to the divider wall 803. As with contacts 814-818, the activation of one of the contacts 819-822 indicates the location or the approximate location of the pusher 825. Locating the contacts along the divider wall 803 can help prevent problems with accidental activation of the contacts by product on the shelf. As with the contacts mounted in the pusher track 802, the distance between contacts 819-822 can be non-uniform so that greater precision is provided as the shelf becomes less full.
- [142] The sensors of the various sensing configurations discussed in the above embodiments may output a signal representing the sensed parameter in either analog or digital format. The analog output may in the form of a voltage or current signal. As one skilled in the art will realize, an analog-to-digital converter may be utilized to transform the analog signal to a digital signal for use by a controller or processing device.

[143] Variations and modifications of the foregoing are within the scope of the present invention. It should be understood that the invention disclosed and defined herein extends to all alternative combinations of two or more of the individual features mentioned or evident from the text and/or drawings. All of these different combinations constitute various alternative aspects of the present invention. The embodiments described herein explain the best modes known for practicing the invention and will enable others skilled in the art to utilize the invention. The claims are to be construed to include alternative embodiments to the extent permitted by the prior art.

[144] Various features of the invention are set forth in the following claims.

We claim:

1. A system for detecting and communicating the position of a pusher assembly on a shelf, comprising:
a sensor assembly configured to detect the position of the pusher assembly, the sensor assembly configured to transmit a code representative of the position of the pusher assembly for further processing.
2. The system of Claim 1, further comprising a processing device configured to receive the transmitted code.
3. The system of Claim 2, wherein the transmission between the sensor assembly and the processing device is wireless.
4. The system of Claim 2, wherein the transmission between the sensor assembly and the processing device is over a network.
5. The system of Claim 1, further comprising an indicia strip containing a pattern of bits, wherein the sensor assembly is configured to scan the indicia strip and determine the code based on the pattern of bits scanned.
6. The system of Claim 1, wherein the sensor assembly comprises an optical sensor.
7. The system of Claim 1, wherein the sensor assembly comprises a capacitive proximity sensor.
8. The system of Claim 1, wherein the sensor assembly comprises a magnetic proximity sensor.
9. The system of Claim 1, wherein the sensor assembly comprises an inductive proximity sensor.

10. The system of Claim 1, wherein the sensor assembly comprises a transmitter and a receiver, the transmitter configured to send a signal to the receiver, the sensor assembly further comprising a timing device, wherein the timing device is used to measure the time for the signal to travel from the transmitter to the receiver.

11. The system of Claim 1, wherein the sensor assembly comprises a transmitter/receiver, a radio frequency identifying transponder, and a timing device, the transmitter/receiver configured to transmit an activation signal to the radio frequency identifying transponder, the transmitter/receiver further configured to receive a responsive signal from the radio frequency identifying transponder in response to the activation signal, and the timing device configured to measure the delay between the transmitting of the activation signal and the receiving of the responsive signal.

12. The system of Claim 2, wherein the processing device receives updated codes in real time.

13. A system for determining the relative location of a pusher assembly from the front of a shelf, comprising:

an indicia strip configured to provide data regarding the position of the pusher assembly;
a sensor connected to the pusher assembly, the sensor configured to scan the indicia strip; and

a controller for activating the sensor and for processing the data scanned by the sensor, wherein the data scanned can be used to determine the position of the pusher assembly.

14. The system of Claim 13, wherein the indicia is associated with a self-coiling sheet.

15. The system of Claim 13, wherein the controller is configured to provide data from the sensor to a store computer.

16. The system of Claim 15, wherein the controller provides data to the computer via a wireless signal.

17. A system for inventory management on a shelf, including a pusher assembly on the shelf, comprising:

an indicia strip configured to provide a representation reflecting the position of the pusher assembly on the shelf;

a sensor assembly configured to transmit a pusher code, the pusher code based on the representation on the indicia strip; and

a store computer configured to receive the pusher code from the sensor assembly.

18. The system of Claim 17, wherein the sensor assembly transmits the pusher code wirelessly.

19. The system of Claim 17, wherein the indicia strip is associated with a self coiling sheet.

20. The system of Claim 19, where the indicia strip comprises a Gray Code pattern.

21. A system for aiding in the prevention of theft of inventory, comprising:
a sensor assembly associated with a pusher assembly for transmitting data relating to the movement of the pusher assembly; and

a store computer configured to receive the data and to transmit a signal in response to the data.

22. The system of Claim 21, further comprising a security camera configured to respond to the signal, the response including the focusing in the direction of the sensor assembly.

23. The system of Claim 22, wherein the store computer is further configured to provide a notification that a deviation in the typical movement of the pusher assembly has occurred.

24. The system of Claim 23, where the notification is sent to in-store security personnel.

25. The system of Claim 21, wherein the sensor assembly monitors the position of the pusher in real time.

26. A system for inventory management, comprising:
an indicia strip configured to provide a representation in a pattern reflecting a position of a pusher assembly;

a sensor assembly configured to scan and transmit a pusher code based on the representation contained on the indicia strip;

an access point configured to receive the pusher code from the sensor assembly and to transmit a signal;

a central access point configured to received the signal; and

a store computer configured to process the signal received by the central access point.

27. The system of Claim 26, wherein the sensor assembly transmits the pusher code in a wireless manner.

28. The system of Claim 26, where the representation on the indicia strip is stored in Gray Code.

29. The system of Claim 26, wherein the indicia strip is configured so that the representation is reflective of not more than four regions.

30. The system of Claim 26, wherein the indicia strip is configured so that the representation is reflective of not more than ten regions

31. A inventory management system for a facing on a shelf, comprising:
a sensor assembly configured for automatic determination of the amount of inventory in a facing; the sensor assembly configured to transmit data regarding the position of a pusher assembly; and

a store computer configured to receive and process data from the sensor assembly.

32. The system of Claim 31, wherein the sensor transmits the data in a wireless manner.

33. The system of Claim 31, wherein the sensor assembly is mounted to the pusher assembly.

34. A system for sensing the removal of a product from a shelf, comprising:
a pusher assembly mounted to the shelf;
an indicia strip configured to provide a representation reflecting the position of the pusher assembly;
a sensor associated with the pusher assembly, the sensor configured to scan the indicia strip; and
a controller configured to measure the position of the pusher assembly via the sensor, the controller being responsive to movement of the pusher assembly.

35. The system of Claim 34, wherein the indicia strip is not more than six bits wide.

36. The system of Claim 34, wherein the indicia strip is not more than two bits wide.

37. The system of Claim 34, wherein the controller is further configured to provide notification that a deviation in amount of product typically removed from the shelf has occurred.

38. An inventory management system for a product on a shelf, comprising:
a sensor assembly for sensing the removal of the product on the shelf, the sensor assembly configured to transmit data regarding the removal of the product; and
a store computer configured to receive data regarding the removal of product

39. The system of Claim 38, wherein the data includes pusher code related to the relative position of a pusher assembly relative to the front of the shelf.

40. The system of Claim 38, wherein the store computer determines the amount of product removed based on a comparison of distance a pusher assembly moves to the dimension of the product being removed from the shelf.

41. An inventory management system for a store, comprising:

a sensor assembly configured to automatically provide data regarding inventory in a facing on a shelf; and

a store computer configured to receive the data from the sensor assembly, wherein the store computer is configured to determine the level of inventory in response to the data provided by the sensor assembly.

42. The inventory management system of Claim 41, wherein the data is provided to the store computer over a network.

43. The inventory management system of Claim 41, wherein the sensor assembly comprises an optical scanner.

44. The inventory management system of Claim 41, wherein the sensor assembly and the store computer are configured for two-way communication and the sensor provides data in response to a query from the store computer.

45. A system for automatic ordering of a product, comprising:
a pusher assembly configured to move the product toward a front side of a shelf;
a sensor assembly configured to sense the position of the pusher assembly and transmit a signal regarding the position of the pusher; and
a store computer configured to receive the signal and to order additional inventory in response to the signal.

46. The system of Claim 45, wherein the store computer determines the level of the product remaining on the shelf based on the signal received from the sensor assembly.

47. The system of Claim 45, wherein the sensor assembly transmits the signal in a wireless manner.

48. A system for use in determining the amount of product on a shelf, comprising:
a pusher assembly, the pusher assembly including a pusher and a coiled spring;
an indicia strip mounted on the coiled spring, the indicia strip containing at least two representations, the representations associated with the position of the pusher;

a sensor assembly configured to scan the indicia strip, the sensor assembly including an optical sensor and a controller, the controller being configured to operate the optical sensor so as to obtain a data reflecting the representation scanned by the sensor, wherein the sensor assembly is configured to transmit a pusher code related to the scanned representation for further processing by a processing device; and

a power source for powering the sensor assembly.

49. The system of Claim 48, wherein the sensor assembly further comprises a receiver, the sensor assembly being configured to transmit a pusher code in response to a query.

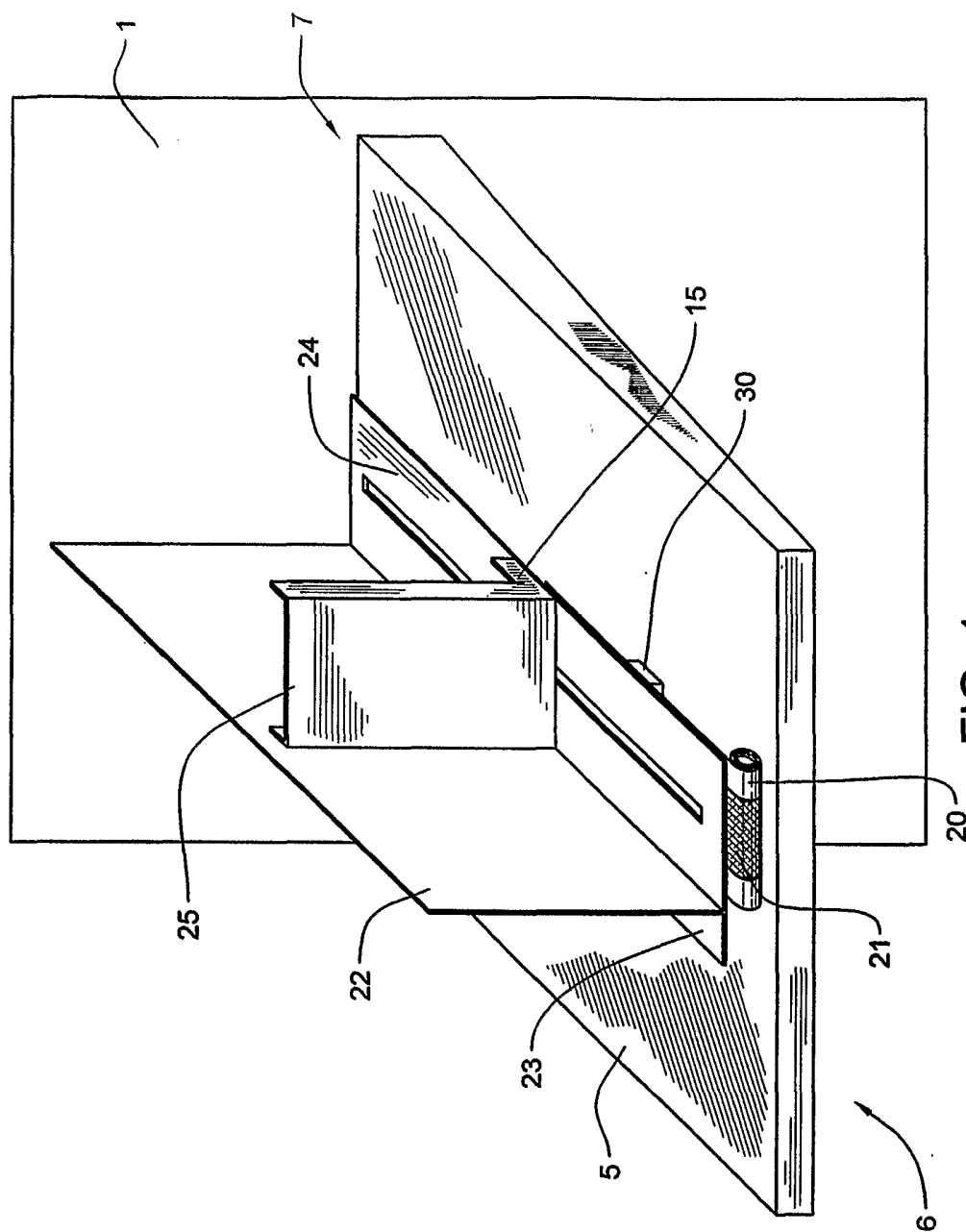

FIG. 1a

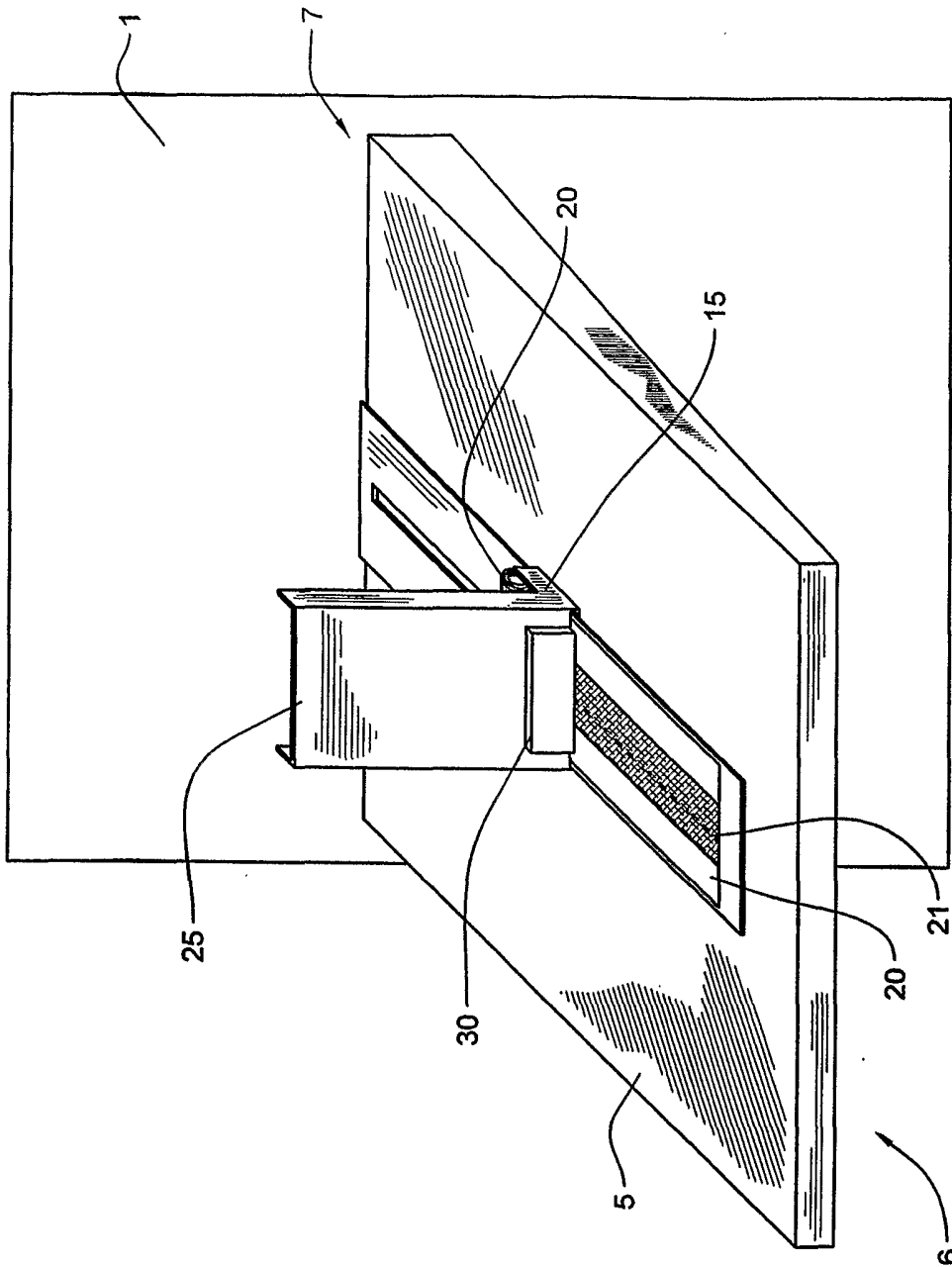

FIG. 1b

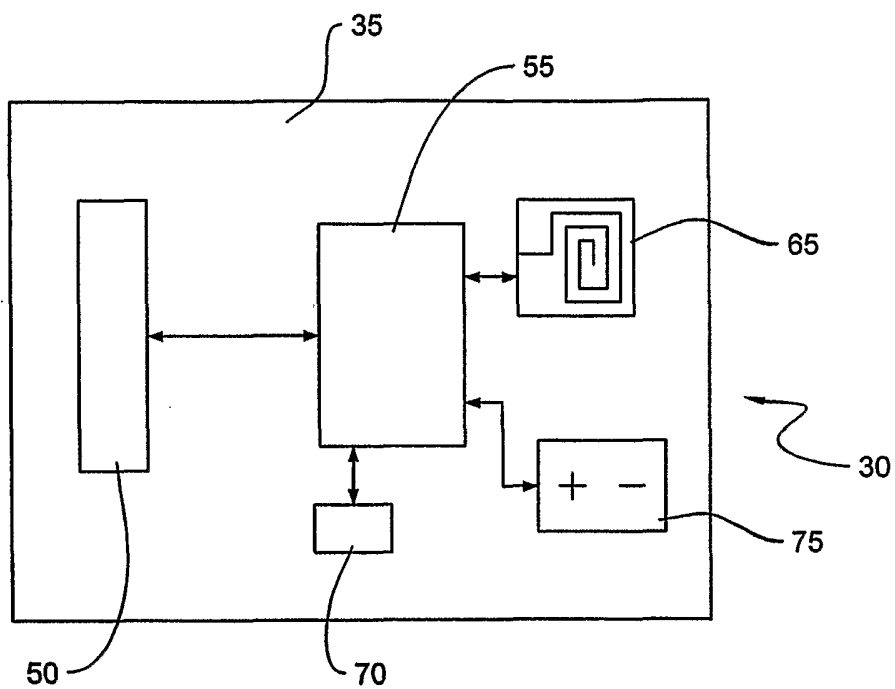

FIG. 2a

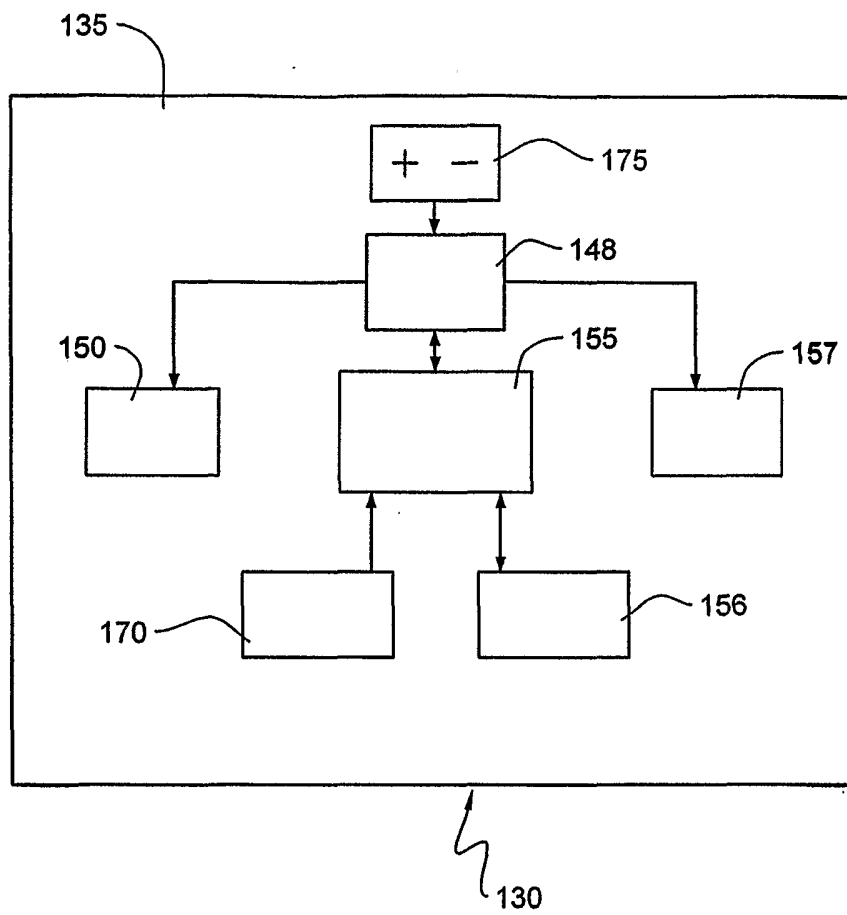

FIG. 2b

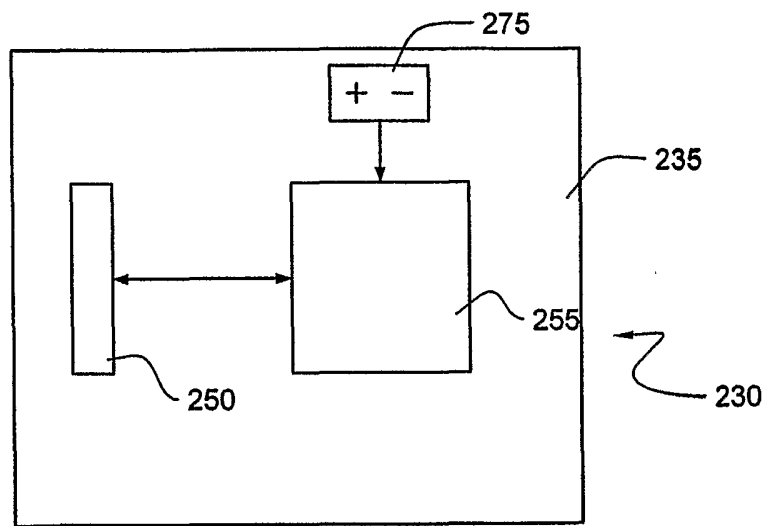

FIG. 2c

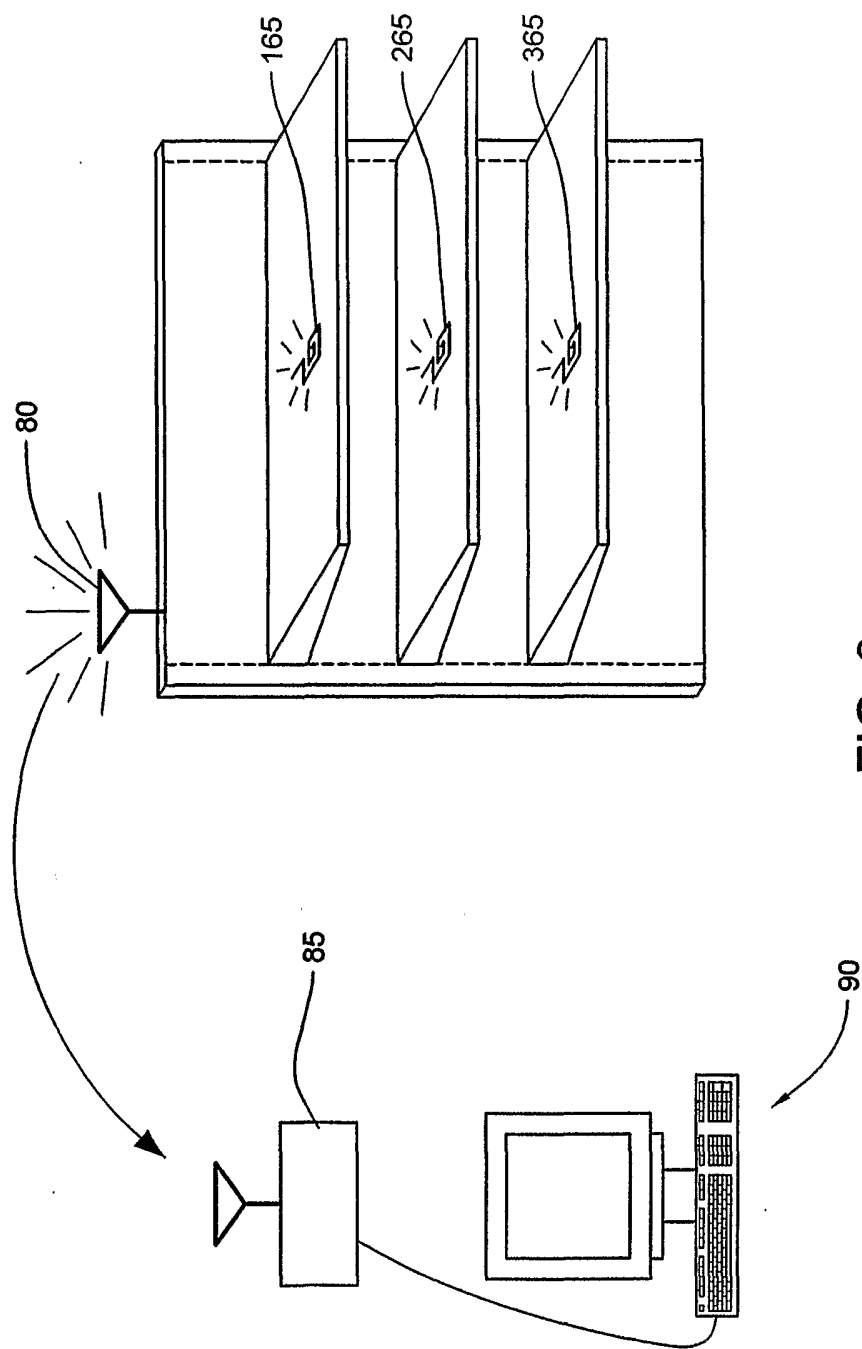

FIG. 3

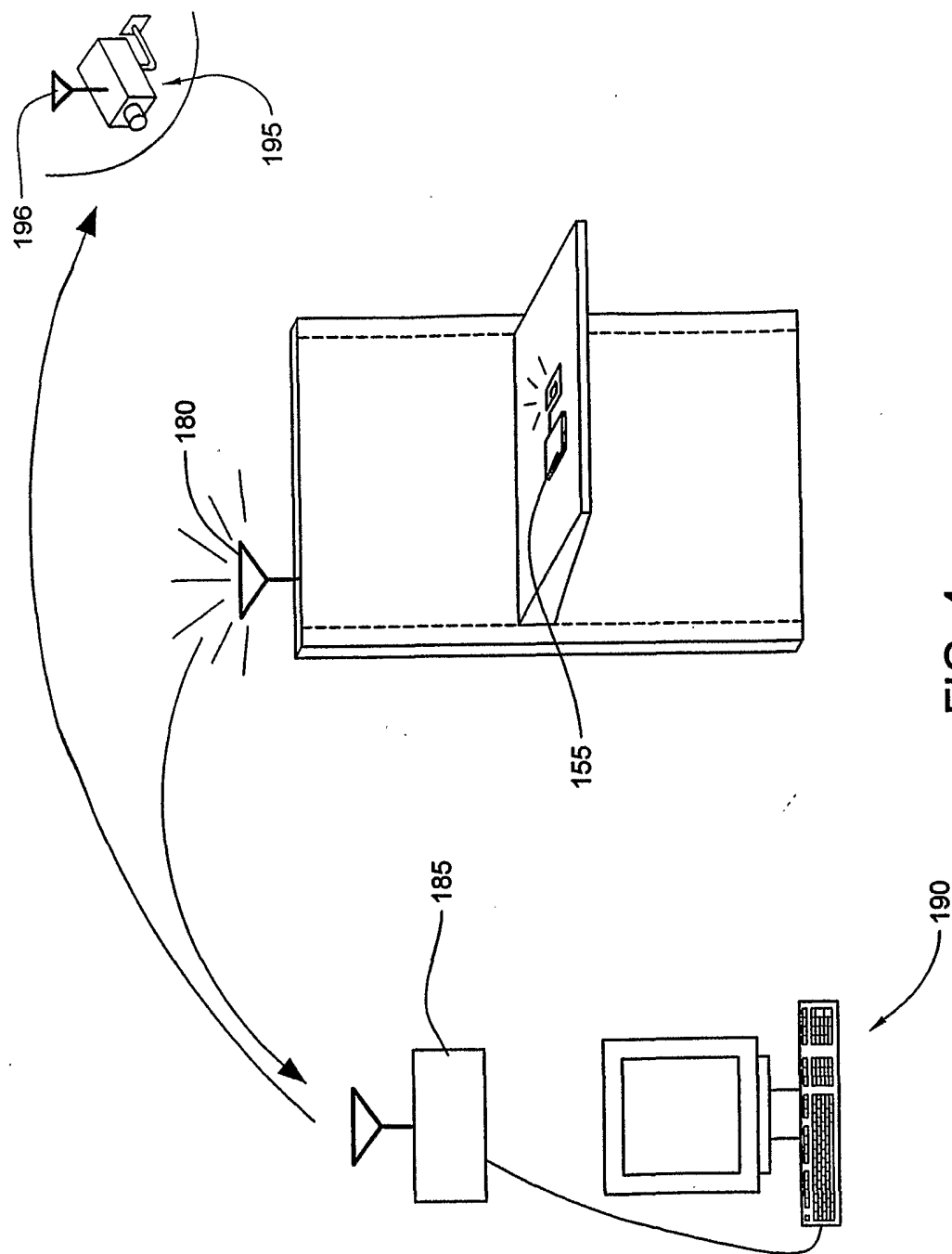

FIG. 4

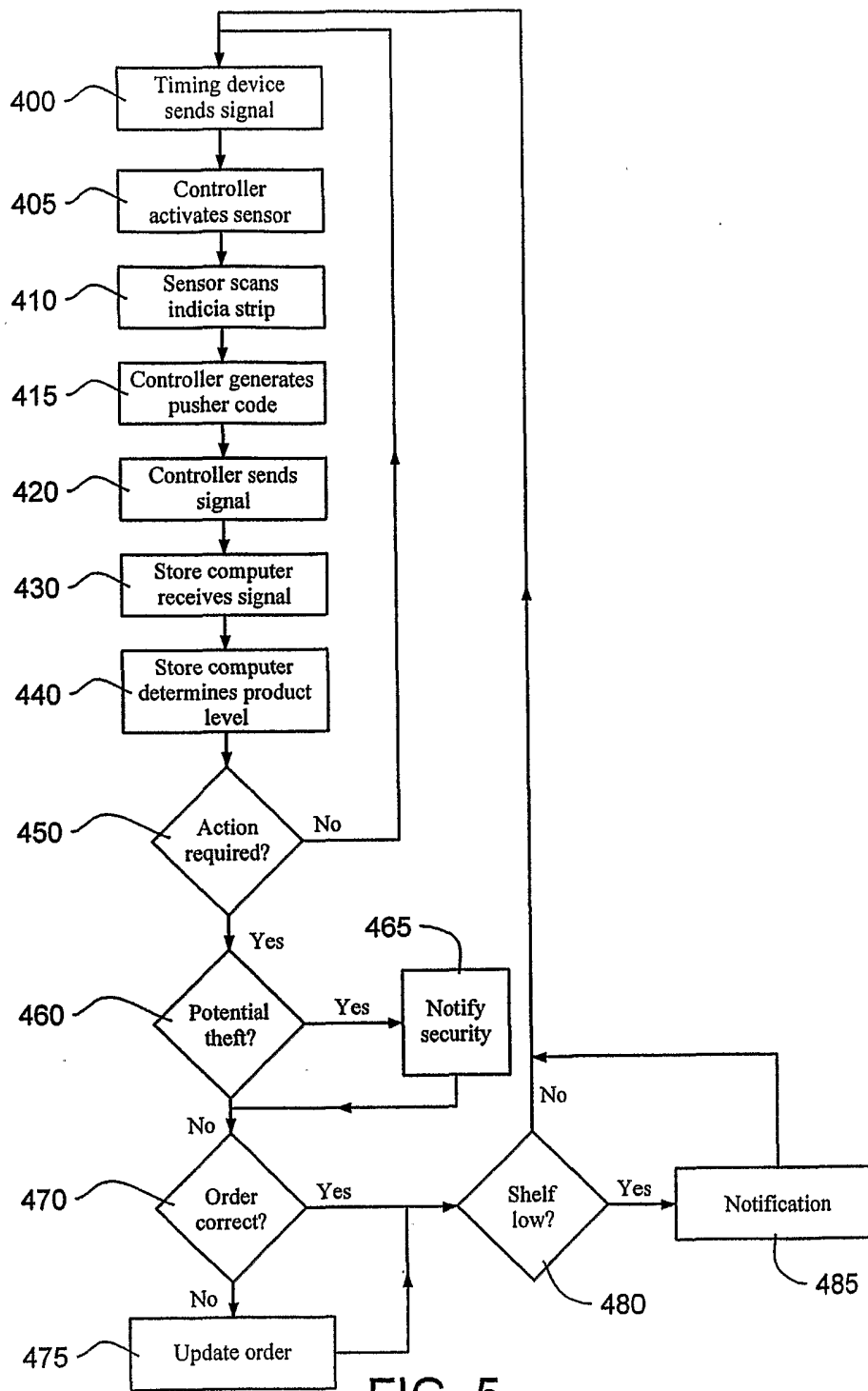

FIG. 5

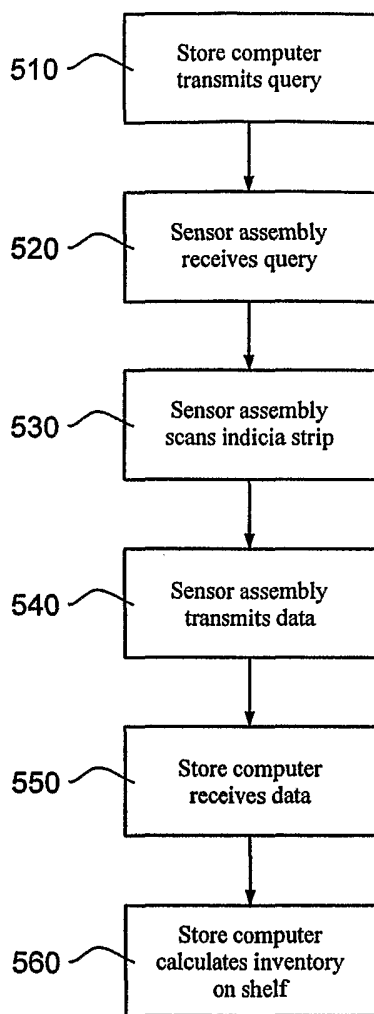

FIG. 6

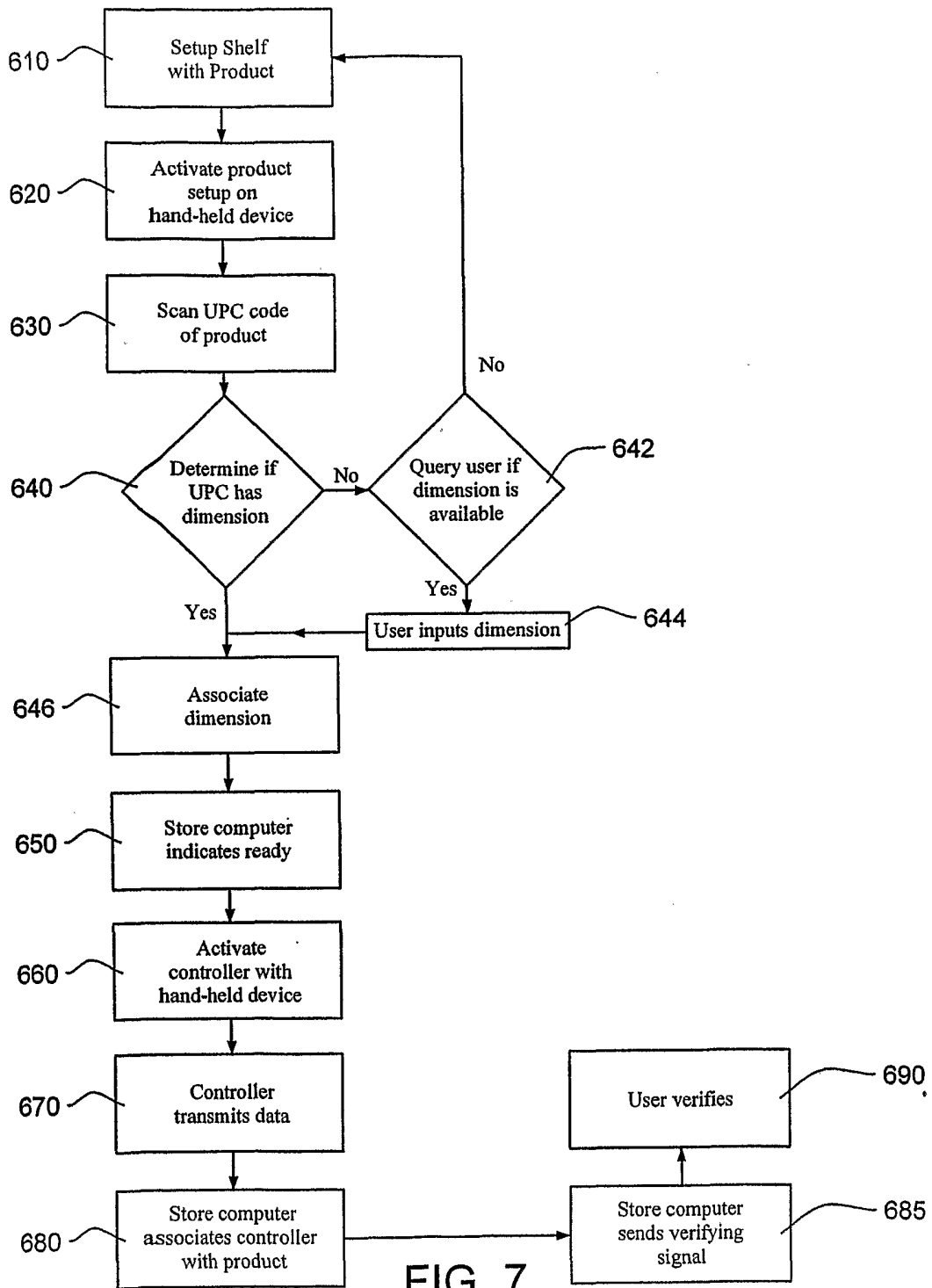

FIG. 7

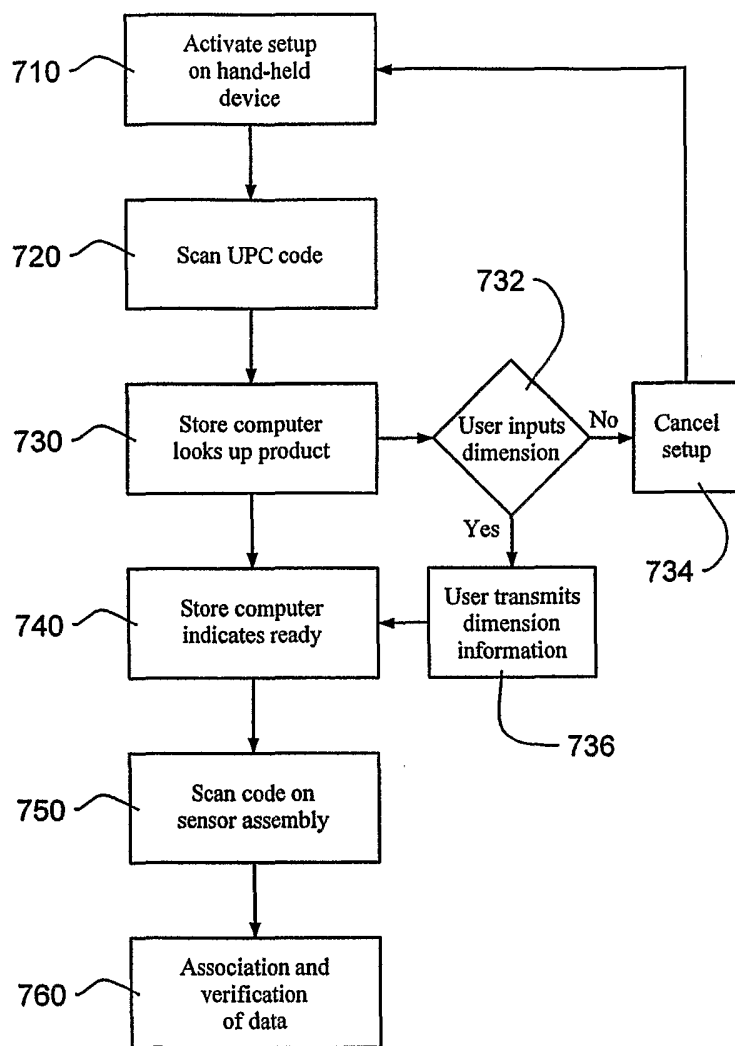
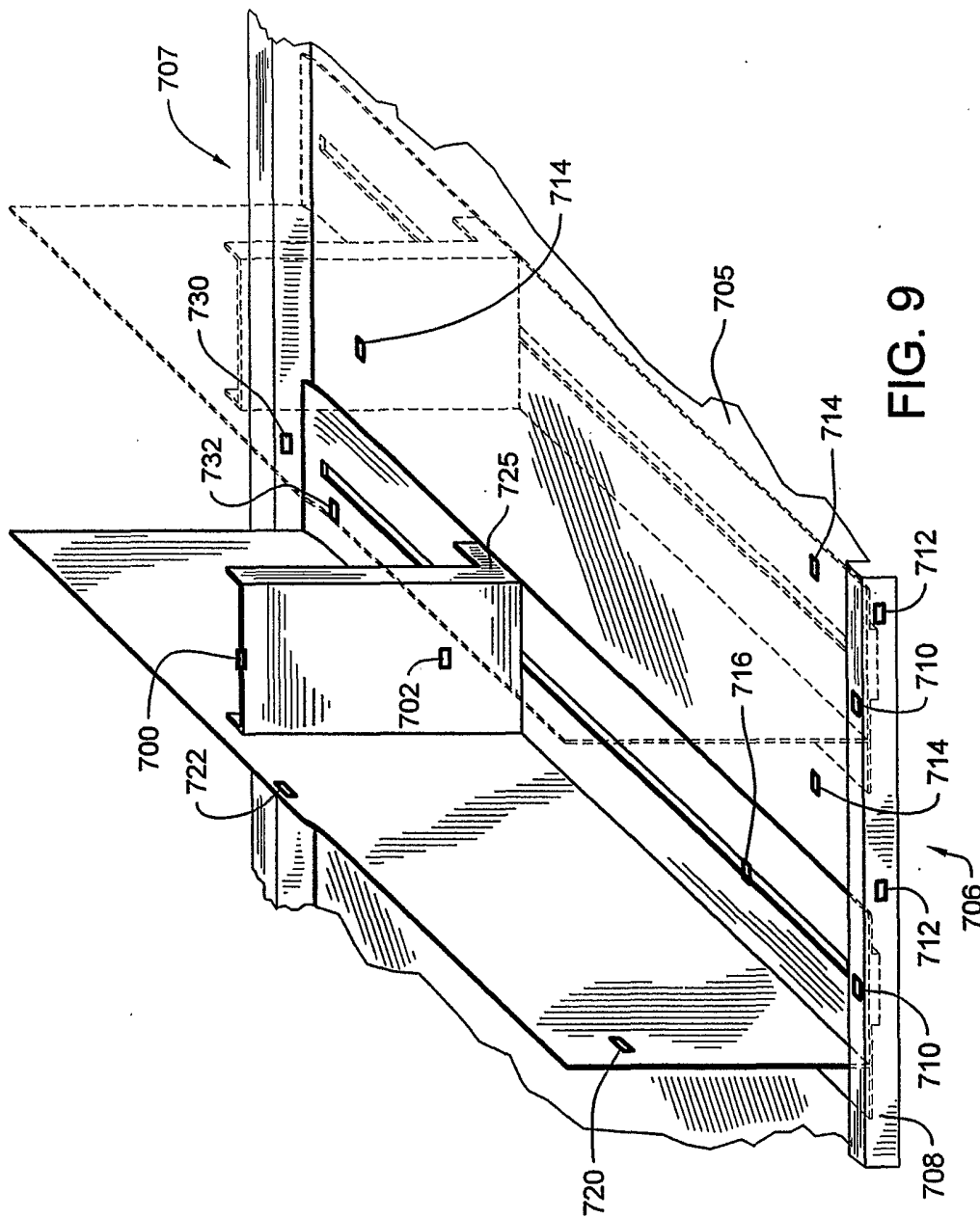
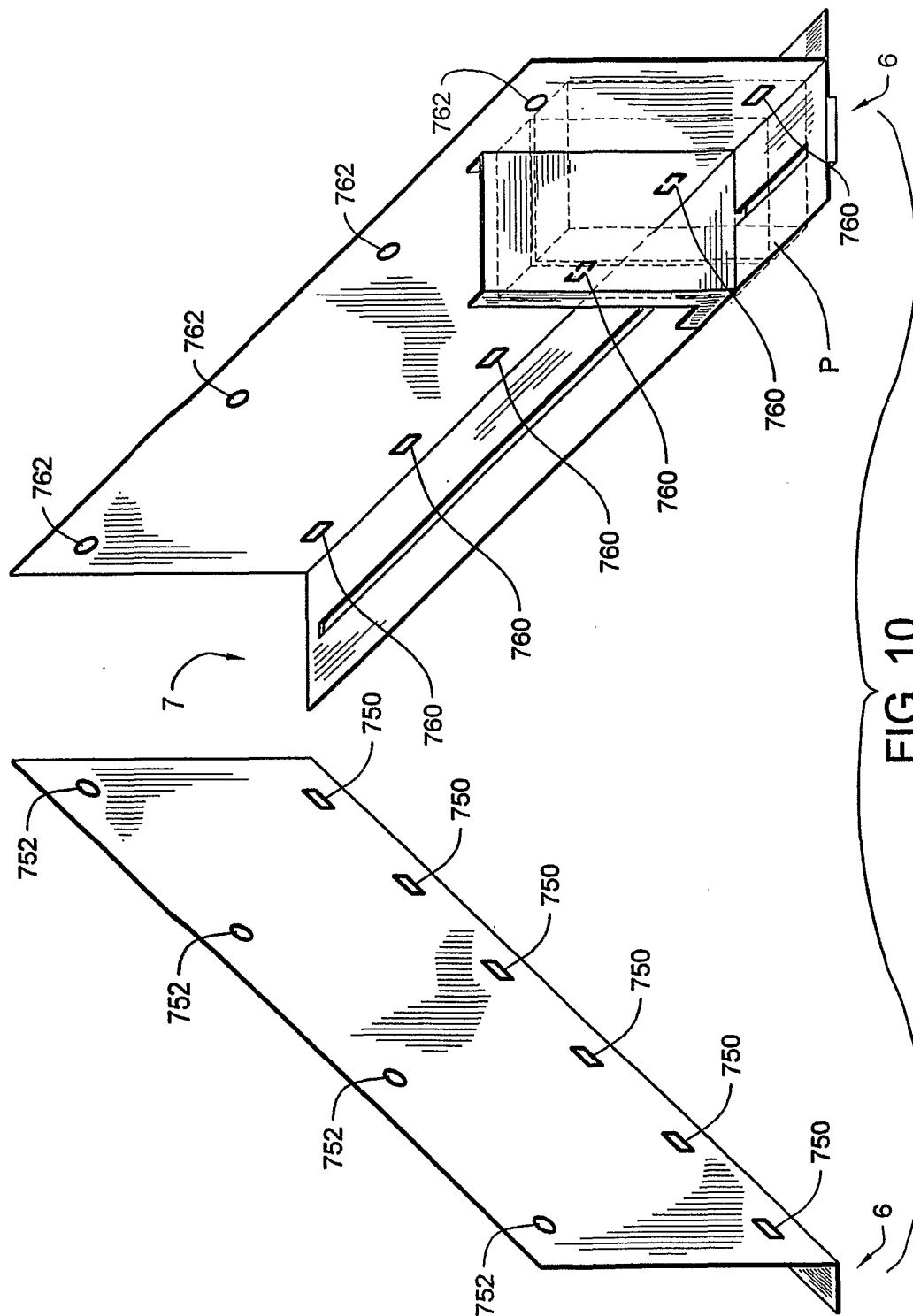

FIG. 8





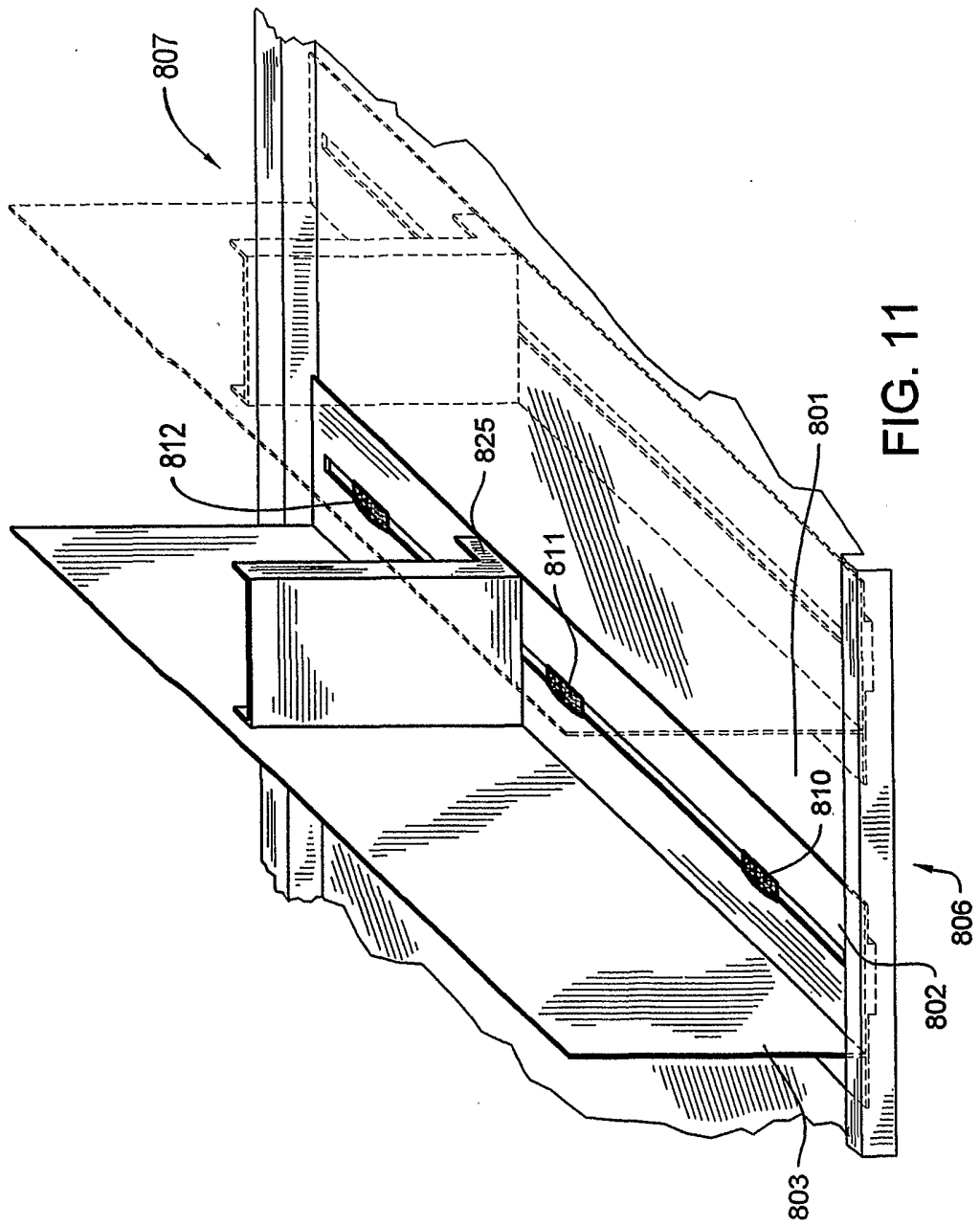

FIG. 11

