

Aug. 26, 1924.

1,506,464

VICTOR GRAF V. ALTEN
COLLAPSIBLE EASY CHAIR, COUCH, ETC

Filed July 22, 1924

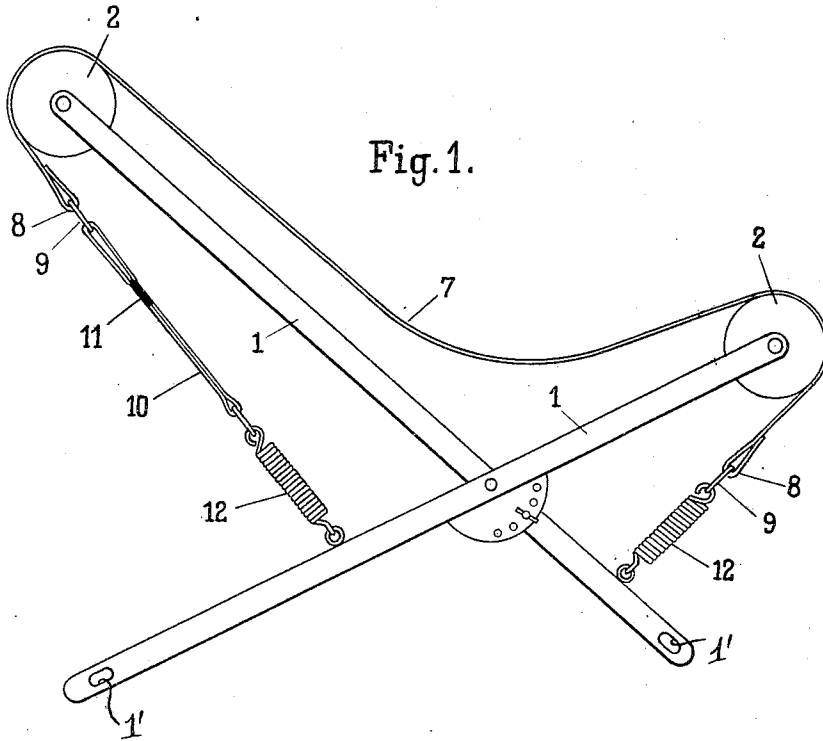

Fig. 1.

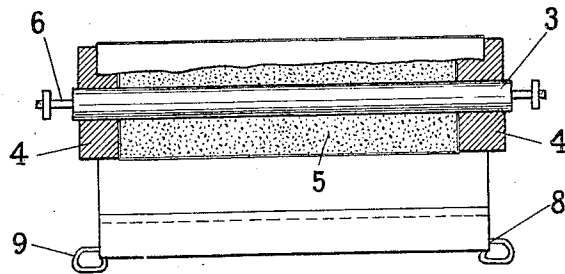

Fig. 2.

Inventor:
Victor Graf von Alten
by *Marks & Clerk*
ATTYS.

UNITED STATES PATENT OFFICE.

VICTOR GRAF v. ALTEN, OF BERLIN-WILMERSDORF, GERMANY.

COLLAPSIBLE EASY CHAIR, COUCH, ETC.

Application filed July 22, 1924. Serial No. 727,560.

To all whom it may concern:

Be it known that I, VICTOR GRAF VON ALTEN, a citizen of the German Republic, residing at Berlin-Wilmersdorf, Germany, have invented certain new and useful Improvements in Collapsible Easy Chairs, Couches, Etc., of which the following is a specification.

It has previously been proposed and become known, in collapsible chairs, couches, etc., to form a hanging seat by making a rectangular piece of flexible material slide over the front and back transversal members and balancing the weight of the occupant by spiral springs, said transversal members being formed by iron rods with or without roller tubes to lessen friction. In an arrangement of this type the springs alone are insufficient to assure a soft, comfortable seat, as the hard cross-members come into immediate contact with parts of the body of the sitting or recumbent person.

My invention relates to improvements in hanging or "hammock" seats, the sitting surface hanging on springs being made to pass over broad, padded, revolving bolsters, with a view of obtaining a soft resilient seat and lessening the wear of the fabric.

In the accompanying drawings Figure 1 shows a side elevation of a folding easy chair, Figure 2 is a cross-section through the revolving bolster, showing the hammock partly removed.

A collapsible frame generally designated 1 is employed and embodies pairs of crossed supporting members the lower portion of which constitute legs being connected together by cross members 1' while the upper portions of the supporting members are connected together by cross members 2 formed by broad revolving bolsters each comprising a wooden cylindrical roller 3 having at each end a disc 4, padding 5, an iron rod 6 passing through the roller 3 and fixed to the frame 1 by nuts. The bolsters revolve on rods 6.

Over said bolsters and overlapping padding 5 is passed the hammock 7, which is kept stretched laterally by rods 8 having eyes 9 and is suspended on spiral springs 12 connected to the leg portions of the main supporting members of the frame. Between the back spiral springs and rod 8 passing through eye 9 is interposed a strap 10 having a shifting-buckle 11.

In his arrangement it is important, that

the padding alone should not carry the full weight of the occupant's body, as this would cause it to be pressed out of shape and thereby to become hard and lose its resilience. Hence the hammock is made to overlap the padding for about one inch or more and to rest on the discs 4, which being solid take the major part of the strain off the padding.

In order to regulate the length and tension of the hammock, dependent on the weight and the requirements of the occupant as well as on the angle at which the members of the frame are placed for sitting or reclining, it is made adjustable by means of straps 10 that can be lengthened or shortened by sliding buckle 11 up or down.

The hammock seat as described is not only limited to folding easy chairs, deck chairs, couches, etc.; the device may also be used for furniture, such as mattresses, stretchers, etc. While I have shown and described the invention in detail it is understood, that variations as to mechanical equivalents of parts shall be within the scope of my invention.

What I claim is:

1. In a chair of the character described, a folding frame including crossed supporting members the lower portions of which constitute legs, cross members connecting the legs, a pair of rotatably padded bolsters forming the upper cross members of the frame and connected with the upper ends of the supporting members, a hammock freely trained over the bolsters, and resilient means connecting the respective ends of the hammock to the leg portions of the cross members of the frame.

2. In a chair of the character described, a folding frame including a pair of rotatable bolsters forming the cross members thereof and each consisting of a supporting rod mounted in the frame, a roller rotatable on the rod, padding surrounding the roller and discs carried by the ends of the roller and confining the padding, a hammock trained over the bolsters, and resilient means connecting the respective ends of the hammock to the frame.

3. A chair as claimed in claim 2, wherein the marginal edges of the hammock engage the discs so as to avoid pressure on the padding.

4. In a chair of the character described, a folding frame including a pair of bolsters constituting the upper cross members of the

frame, each bolster including a supporting
rod fixed in the frame, a cylindrical roller
rotatable about the rod, padding surround-
ing the roller and discs carried by the ends
5 of the roller and confining the pad, a ham-
mock trained over the bolsters being wider
than the padding and engaging the discs so
as to relieve the major part of the strain
from the padding, spiral springs for con-
10 necting the respective ends of the hammock

to the frame, and an adjusting means for
the hammock interposed between the springs
and the hammock, substantially as and for
the purposes set forth.

In testimony whereof I have affixed my 15
signature in presence of two witnesses.

VICTOR GRAF v. ALTEN.

Witnesses:

WLAD. ENDER.

ERWIN C. RUSSCHEWITZ.