

(No Model.)

A. DOM.  
SHIFTING SEAT FOR VEHICLES.

No. 426,782.

Patented Apr. 29, 1890.

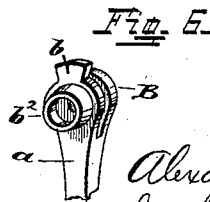
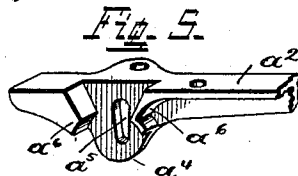
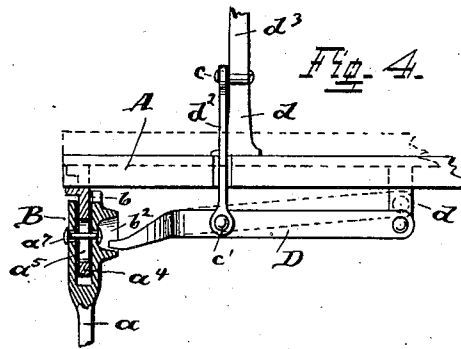
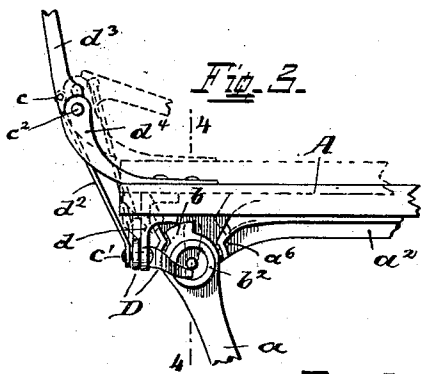
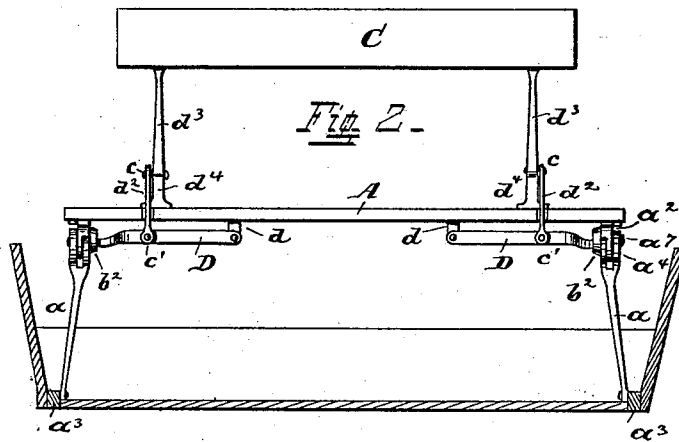
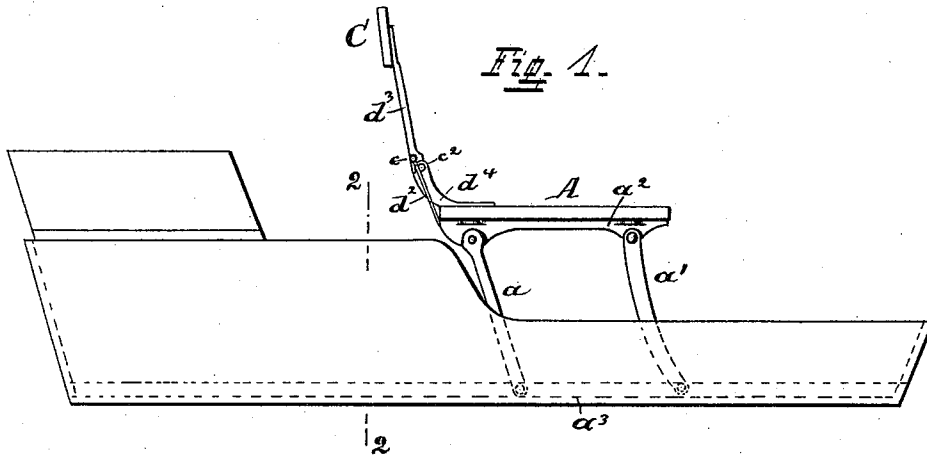

Attest  
Ed. Strehli  
W. S. Hartley

Inventor  
Alexander Dow  
Strehli & Hill  
Attys

# UNITED STATES PATENT OFFICE.

ALEXANDER DOM, OF MOUNT HEALTHY, ASSIGNOR TO THE STANDARD CARRIAGE IRON COMPANY, OF CINCINNATI, OHIO.

## SHIFTING SEAT FOR VEHICLES.

SPECIFICATION forming part of Letters Patent No. 426,782, dated April 29, 1890.

Application filed September 25, 1889. Serial No. 325,048. (No model.)

*To all whom it may concern:*

Be it known that I, ALEXANDER DOM, a citizen of the United States, residing at Mount Healthy, in the county of Hamilton, State of Ohio, have invented certain new and useful Improvements in Shifting Seats for Vehicles, of which the following is a specification, reference being had to the accompanying drawings, forming a part thereof.

My invention relates to the device hereinafter set forth for elevating the rear portion of the front seat from off the rear oscillating legs out of a locked position thereto in order that said seat may be folded backward or forward, and is an improvement upon the shifting seat shown and described in Letters Patent No. 385,831, dated July 10, 1888.

In the accompanying drawings, Figure 1 is a side elevation, and Fig. 2 is a rear elevation, of a vehicle-seat provided with my invention. Fig. 3 is an inner side view of my device in operation, the dotted lines indicating the relative position of the different parts when the rear portion of the seat is elevated from off the rear legs out of a locked position. Fig. 4 is a rear elevation of my improved lifting device and a sectional view of the top portion of one of the rear oscillating legs, showing their relative positions when in a locked position, the dotted lines indicating their positions when the seat is unlocked from said legs. Figs. 5 and 6 are perspective views, respectively, of a portion of the seat-plate and one rear oscillating leg, which form the locking device for the seat when placed together in an operative position, as shown in Figs. 3 and 4.

The seat A is supported by the oscillating legs  $a$   $a'$  at each side thereof, the top portion of each leg being pivoted to the seat-plate  $a^2$  and the bottom portions of said legs being pivoted to the body-plate  $a^3$ , as shown. The rear legs  $a$  are each provided with a bifurcated enlarged head B, one of said portions having the lug  $b$  cast thereto. The rear portion of each seat-rail  $a^2$  is provided with a downward extension  $a^4$ , having therein the elongated opening  $a^5$  and the stop lugs or shoulders  $a^6$ . The extension  $a^4$  of the seat-rail fits in and operates between the two portions of the bi-

furcated head B, and is secured therein by means of a suitable bolt  $a^7$ , as shown more particularly in Figs. 2 and 4, in which position said bifurcated rear legs are free to oscillate for a limited distance until the lug  $b$  comes in contact with one of the stop-lugs  $a^6$ , in which position the seat is held to place. The seat and plates  $a^2$  are free to be elevated out of a locked position by reason of the elongated opening  $a^5$  in said plates.

The mechanism thus far described is the same as that shown and described in the aforesaid Patent No. 385,831, and is for the purpose of allowing a limited movement of the front seat in order to permit of more space for ingress to and egress from the rear seat, as is fully set forth and claimed in said patent.

In order to fold or knock down the front seat when constructed in the manner described and shown in the said patent, it is necessary for the driver or other person to lift the rear of the seat by hand until the lugs  $a^6$  on the seat-plate are above a curvilinear line with the top of lugs  $b$  on the rear legs, in which position the seat is free to be folded in either direction. This feature of lifting the rear of the seat by hand, especially when standing on the ground, is a very laborious and annoying one, which my invention is intended to greatly lessen or obviate, and is constructed as follows:

To the inner face of the bifurcated heads B is cast a circular collar or a lug  $b^2$ , circularly countersunk, as shown, in which the free end of bar D rests, as shown in Figs. 2 and 4. This bar D is pivoted at its other end to the projection  $d$ , made fast to the bottom of the seat. Near the center of said bar is pivoted the rod  $d^2$ , the other end of said rod being pivoted to the support  $d^3$  of the lazy-back just above the pivotal point  $c^2$  of the support  $d^3$  and auxiliary support  $d^4$ . It will be seen by the above arrangement and location of the different parts of the lifting device that the rod  $d^2$  remains stationary and acts as a base or support, to which the supports  $d^3$  of the lazy-back are pivoted, which supports act as a lever, and so soon as the lazy-back and its supports  $d^3$  are folded forward and the piv-

otal point  $c$  has passed beyond a vertical line with the pivotal point  $c^2$  a leverage is had on said rod  $d^2$ , which causes the auxiliary supports  $d^4$  to be elevated, and with them the rear portion of the seat. The bar D, being pivotally connected to the projection  $d$  attached to the rear of the seat, will admit of said seat being elevated at rear, while the free end of said bar rests in and bears against the lower inner face of the collar or lug  $b^2$ , as shown.

While I have described the construction of but one lifting device, two such devices constructed as above described are employed— one at each side the rear portion of the seat— both operating at the same time and by the swinging motion of the lazy-back.

The operation of my improved shifting seat is as follows: When the seat is elevated in an operative position, the seat is free to be moved forward for a limited distance, as aforescribed, as the weight of bar D, resting in the lug or collar  $b^2$ , does not in any way interfere with the rocking motion of the rear legs  $a$ . When desired to convert the vehicle into a single-seated one, all that is required is simply to fold the lazy-back forward, which will cause the rear portion of the seat and plates  $a^2$  to be elevated until the lugs  $a^6$  on said plates are elevated above the curvilinear line of the lugs  $b$  on the rear legs, when said seat is unlocked and free to be folded backward, after which the rear seat is swung forward over the folded front seat in the usual manner.

If desired, the bars D may be formed in one piece extending from one rear oscillating leg to the other and not connected to the seat.

The means hereinbefore described for elevating and unlocking the rear of the seat may be used in connection with other forms of operative oscillating supports than that herein specifically set forth.

The advantages of my invention are apparent, being simple of construction and operation and cheap of manufacture. The convenience afforded over the old way of lifting and unlocking the seat by hand is a very great advantage.

What I claim as new, and desire to secure by Letters Patent, is—

1. In combination with a shifting seat mounted upon oscillating legs and adapted to rest therein in a locked position when in use and capable of being unlocked and folded when not in use, the means herein shown and described for elevating and unlocking the rear portion of the seat, consisting of bars pivotally connected at one end to projections attached to the seat, the other end of said bars resting in suitable collars or counter-sunk lugs on the rear legs, and suitable rods pivotally connected to said bars and to the back-supports, substantially as set forth.

2. In combination with a shifting seat mounted upon oscillating legs and adapted to rest therein in a locked position, the means herein shown for elevating the rear of said seat and rails, consisting of bars D, pivotally connected at one end to projections  $d$ , attached to the seat, the other end of said bars resting in collars or lugs  $b^2$  on the rear legs  $a$ , and rods  $d^2$ , pivotally connected to bars D and to the back-supports  $d^3$ , the latter being pivotally connected to the auxiliary supports  $d^4$ , made fast to the rear of the seat, as set forth.

3. In a shifting seat, the plates  $a^2$ , having projections  $a^4$ , with an elongated opening  $a^5$  therein, and stop-lugs  $a^6$ , said projections resting in the bifurcated heads B of legs  $a$ , each of said heads having the lug  $b$  and collar  $b^2$ , in combination with bars D, pivotally connected at one end to projections  $d$  and resting at their free end in said collars  $b^2$ , and rods  $d^2$ , pivotally connected to said bars and to the back-supports  $d^3$ , the latter being pivotally connected to the auxiliary supports  $d^4$ , substantially as set forth.

4. In combination with a seat mounted upon oscillating legs, the means herein described for elevating and unlocking the rear of said seat from the rear leg-supports, consisting of a bar resting in a circular collar attached to said rear leg-supports, and rods pivotally connected to said bar and to the lazy-back supports, the latter being pivotally connected to the auxiliary supports made fast to the seat, substantially as described.

ALEXANDER DOM.

Witnesses:

O. M. HILL,  
ED. STREHLI.