

F. J. BALLINTINE.
COMBINATION BLAST AND EXHAUST HEATING DEVICE.
APPLICATION FILED MAR. 1, 1906.

3 SHEETS—SHEET 1.

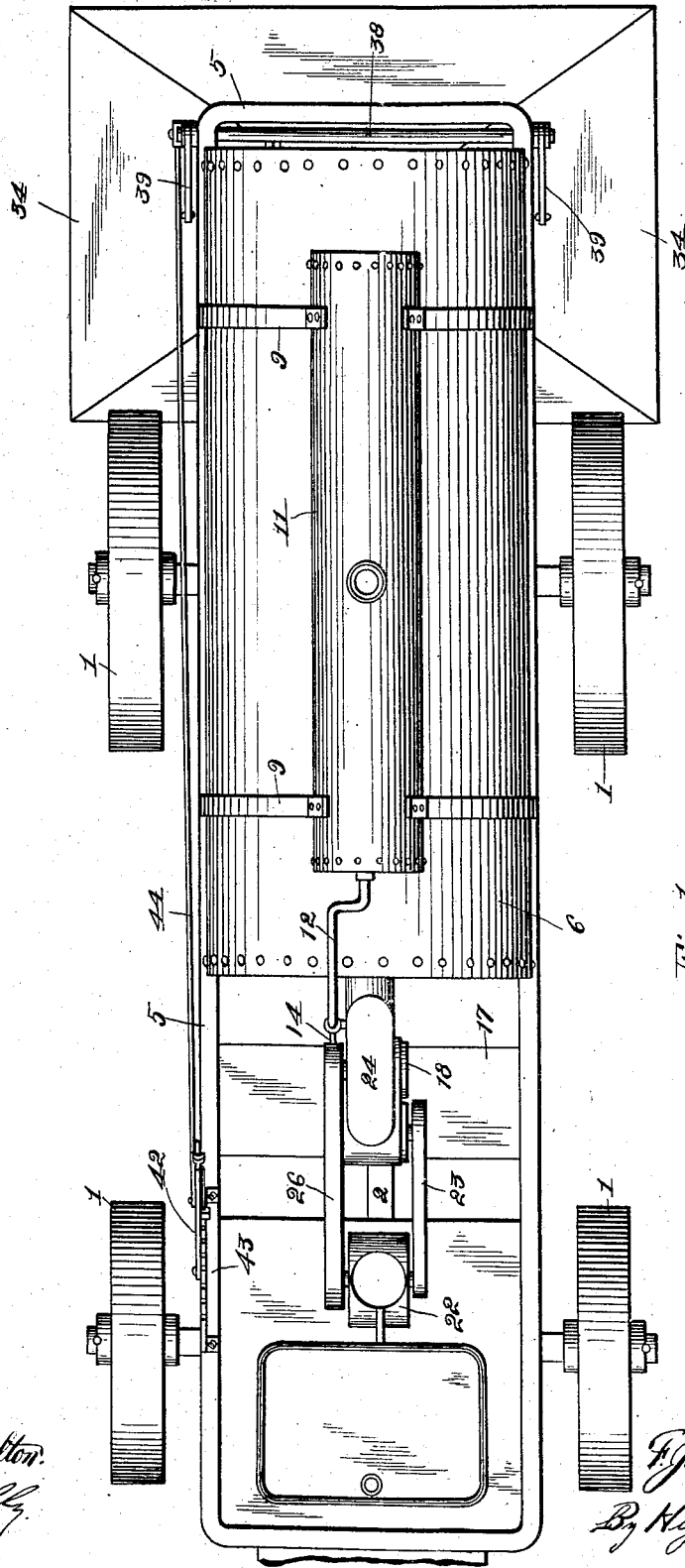

Fig. 1

Witnesses:
R. C. Hamilton
M. Kelly

Inventor,
F. J. Ballintine
By *Higdon & Higdon*,
Attys.

F. J. BALLINTINE.
COMBINATION BLAST AND EXHAUST HEATING DEVICE.
APPLICATION FILED MAR. 1, 1906.

3 SHEETS—SHEET 2.

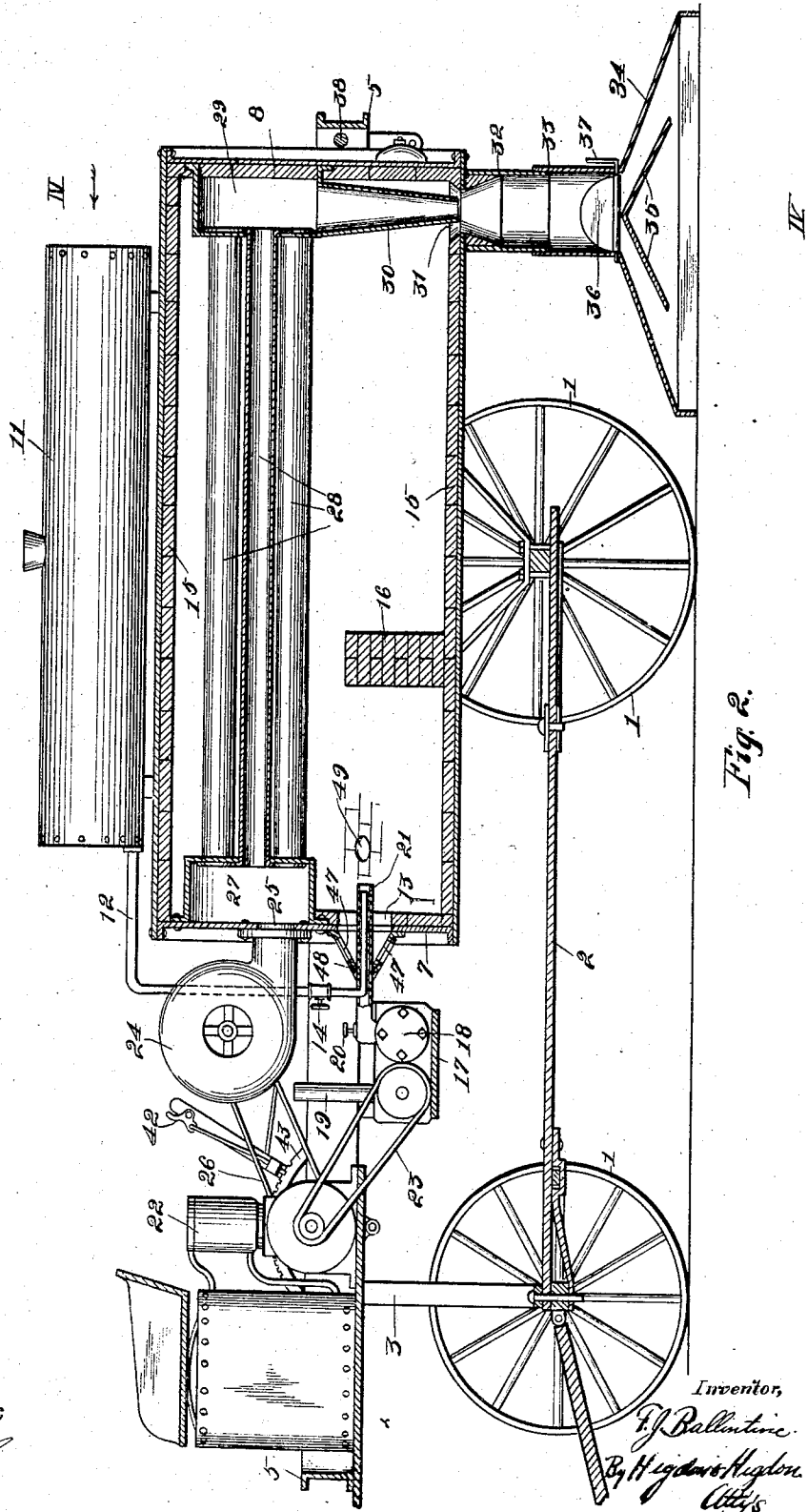

Fig. 2.

Witnesses:
R. Hamilton
A. Kelly

Inventor,
F. J. Ballintine
 By *H. J. Adams*,
 City

No. 864,062.

PATENTED AUG. 20, 1907.

F. J. BALLINTINE.
COMBINATION BLAST AND EXHAUST HEATING DEVICE.

APPLICATION FILED MAR. 1, 1906.

3 SHEETS—SHEET 3.

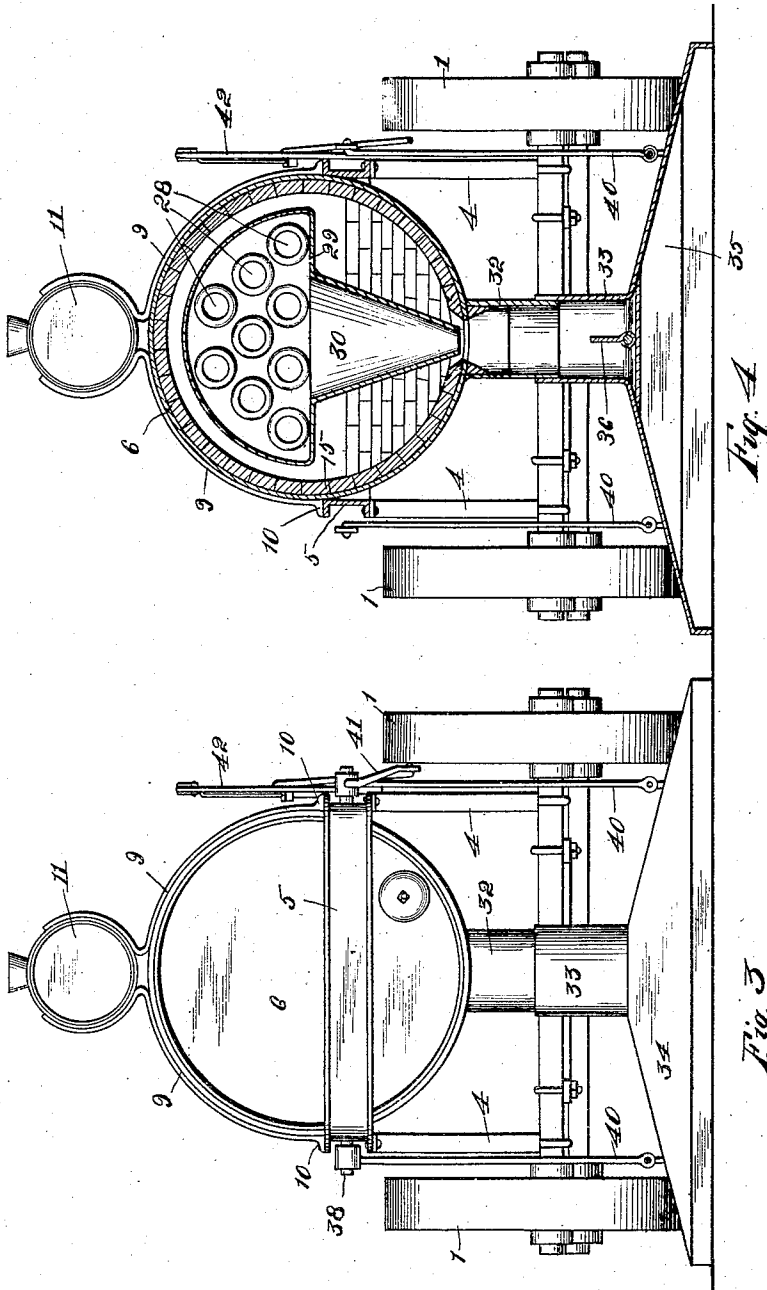

Witnesses:
W. W. Single.
M. Kelly

Inventor:
F. J. Ballintine
By Higdon & Higdon.
Attys

UNITED STATES PATENT OFFICE.

FRANK J. BALLINTINE, OF KANSAS CITY, MISSOURI, ASSIGNOR TO THE PARKER-WASHINGTON CO., OF CHARLESTOWN, WEST VIRGINIA, A CORPORATION OF WEST VIRGINIA.

COMBINATION BLAST AND EXHAUST HEATING DEVICE.

No. 864,062.

Specification of Letters Patent.

Patented Aug. 20, 1907.

Application filed March 1, 1906. Serial No. 303,642.

To all whom it may concern:

Be it known that I, FRANK J. BALLINTINE, a citizen of the United States, residing at Kansas City, in the county of Jackson and State of Missouri, have invented a new and useful Improvement in Combination Blast and Exhaust Heating Devices, of which the following is a specification.

My invention relates to repairing devices for asphalt pavements, and specifically relates to a device for heating and softening the material at the sides and bottom of a depression by means of a blast of highly heated air. As is well known, the object of such heating and softening is to cause the fresh material to adhere strongly where applied in filling up the depression.

To this end my invention consists in certain novel and peculiar combinations and construction of parts, as hereafter described and claimed; and in order that the same may be fully understood, reference is had to the accompanying drawings, in which,

Figure 1 is a top plan view of an apparatus embodying my invention. Fig. 2 is a partly sectional side elevation of the same; Fig. 3 is a rear elevation of the same; Fig. 4 is a vertical section taken on line iv-iv of Fig. 2, looking forward.

For convenience of transportation the apparatus is mounted on a running gear comprising wheels, a reach 2, an arch 3 supported by the front axle, and a pair of inverted arches 4 supported by the rear axle. Arches 3 and 4 support a rectangular steel frame 5, which supports the apparatus described hereinafter. The space inclosed by the rear portion of the frame is occupied by a metallic cylindrical shell 6 having closed ends, or head, 7 and 8. Said shell is supported by lugs 10 of two straps 9, riveted thereto, said lugs resting upon the frame-bars 5. The upper ends of straps 9 are bent as shown in Fig. 3, and form supports for a crude-oil tank 11. From tank 11 an outlet pipe 12 passes down and then rearwardly through an opening 13, of larger diameter, in the head 7, and terminates a short distance within the shell 6. Said pipe is provided with a cut-off and regulating valve 14. The shell of 6 is lined with a layer of fire-brick 15, excepting part of its forward head 7. The brick-lined shell 6 forms a combustion chamber and is provided with a brick-wall 16, constructed of brick, by preference. Supported by a platform 17 in front of said shell, is a rotary air pump, or blower 18, of which 19 is the inlet pipe. The outlet pipe 21, provided with a hand valve 20, is of larger diameter than the crude-oil pipe 12, and surrounds the latter for a short distance, as shown. To permit this, a suitable opening is cut into pipe 21 to

pass the other. The air-pipe 21 terminates at about the same point as the oil-pipe 12. Through the space between these pipes, a current of air passes causing the oil to spray into the combustion chamber when the pump 18 is in operation. Said pump is driven by an engine 22, through belt 23. The opening 13 is covered by a cone 46, concentric with pipe 21, and said cone is provided with air-inlets 47, and also with an outer rotatable cone 48, also having openings 47, adapted to register with those of the inner cone. By turning the outer cone, which is properly a damper, the draft into the combustion chamber 6 may to some extent be regulated. A second and larger air blower 24, has its outlet connected to an opening 25 in the head 7. This blower is also driven by the engine 22, through a belt 26. Opening 25 does not communicate with the body of the combustion chamber, but opens into a semicircular drum 27, secured to the head 7. From this drum, a plurality of air-flues 28 extend rearwardly and are connected to a second semicircular drum 29, at the rear of the combustion chamber. Drum 29 is provided with a downwardly-tapering nozzle 30, which terminates in the center of a circular opening 31, of larger diameter, through the brick lining and shell 6. A large depending tube 32 is attached to the shell 6 below said opening 31, and mounted telescopically on tube 32 is the upper tubular portion 33 of a sheet-metal hood 34, the sides or top of which are inclined downwardly and outwardly. The hood is provided with a spreader-plate 35, having oppositely-inclined portions, the junctions of which is to spread the blast of heated air over the entire surface of asphalt covered by the hood. A semi-circular damper 36, carried by a stem having a handle 37, may be cut off from either side of the hood, at the will of the operator.

A preferred means for raising and lowering the hood, consists, as shown, of a transverse rock-shaft 38 having two arms 39, depending rods 40 connecting said arms to the hood, a third arm 41 on shaft 38, a hand lever 42 having a latch and segment 43, and a connecting-rod 44 connecting said lever to rocker-arm 41. To raise the hood 34, the lever 42 is moved forward; to lower the hood, rearward, and the latch and segment hold the hood at any desired height. The rock-shaft 38, as shown, is journaled by passing through the side bars 5 of the frame.

The operation is substantially as follows: The machine is stopped in such a position that the hood 34 covers all or a portion of the surface to be heated. Oil valve 14 is opened part way, and the oil spray issuing

from the burner pipe 12 is ignited by inserting a match or torch through an opening 49 in the chamber 6. The engine 22 is started, thereby putting the blowers 18 and 24 into operation. The hood is lowered until it is in contact with the pavement. Air is drawn into the blowers 18 and 24, and from the latter it is forced through the flues 28 into rear from 29, through nozzle 30 and tubes 32 and 33 into the hood creating a suction which exhausts the heated contents of the combustion chamber and drives the heated gases and products of combustion down onto the surface to be heated. From the other blowers a blast of air issues from pipe 21, feeding the flame, and passes over the bridge wall 16, back through the combustion chamber, down through the outlet opening 31, and into the hood. Thus the draft through the combustion chamber is maintained by the injector-like action of the air blast issuing from the nozzle 30. An additional flow of fresh air enters through the damper 48 if the same be opened and also through opening 49. The air-flues 28 become heated to redness by the flame in the combustion chamber. Therefore the air which traverses there and passes into the hood 34 carrying with it the contents of the combustion chamber is heated to a very high temperature and the asphalt is thereby softened or melted, as the case may be. By raising the hood the heated surface can be inspected or tested at any time. The rapidity with which the pavement is heated can be regulated by regulating the speed of the engine, which runs the blowers. The products of combustion are of course drawn down through openings 31 into the hood, and pass from under the hood into the atmosphere. When the material has become sufficiently softened, the hood is moved away, and fresh material is applied in the usual

manner until the depression is filled up flush with the surrounding surface.

Having now described my invention, what I claim and desire to secure by Letters Patent, is:

1. In an asphalt repairing device, a portable combustion chamber having one or more air inlets and an air outlet; a hood a trunk leading from said outlet to the hood; a plurality of air-flues leading from one of said inlets to a drum at the opposite end of said chamber; a nozzle extending from the drum to a point within said outlet; means for a current of air through said flues; and heating means located within the combustion chamber.

2. In an asphalt pavement repairing device, a portable combustion chamber having one or more air inlets and an air outlet; a hood; a trunk leading from said outlet to the hood; a plurality of air-flues leading from one of said inlets to a drum at the opposite end of said chamber; a nozzle extending from the drum to a point within said outlet; means for impelling a current of air through the flues; an oil burner within the combustion chamber at one end thereof; a blower, and a discharge pipe therefor leading from the blower and surrounding the burner pipe.

3. In an asphalt pavement repairing device, a portable combustion chamber having a bridge-wall and an air outlet, an oil burner at one end of said chamber, an air blast pipe surrounding the burner pipe, a blower, two drums arranged at opposite ends of the upper portion of said chamber, air flues connecting said drums, an air-inlet pipe connecting the blower to one drum, an exhaust nozzle extending from the other drum to said air-outlet, and arranged to exhaust the products of combustion and the heated air from the combustion chamber, a hood, and a trunk connecting said outlet to the hood.

In testimony whereof I affix my signature in the presence of two witnesses.

FRANK J. BALLINTINE.

Witnesses:

ELEANORE C. WALTON,
PEARL A. GHRIST.