

Nov. 30, 1965

J. P. FECHTER
ALLEY TRAVERSING MECHANISM FOR SETTING PINS AND
FOR DELIVERING BALLS AND DOWNED
PINS TO THE BOWLER
Filed Dec. 17, 1962

3,220,728

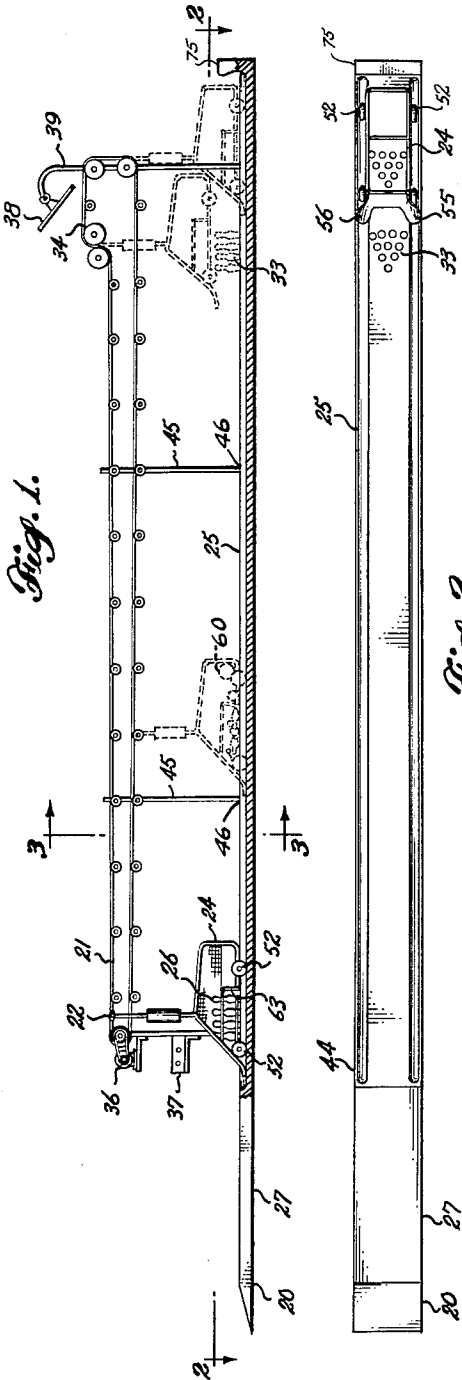

Fig. 1.

Fig. 2.

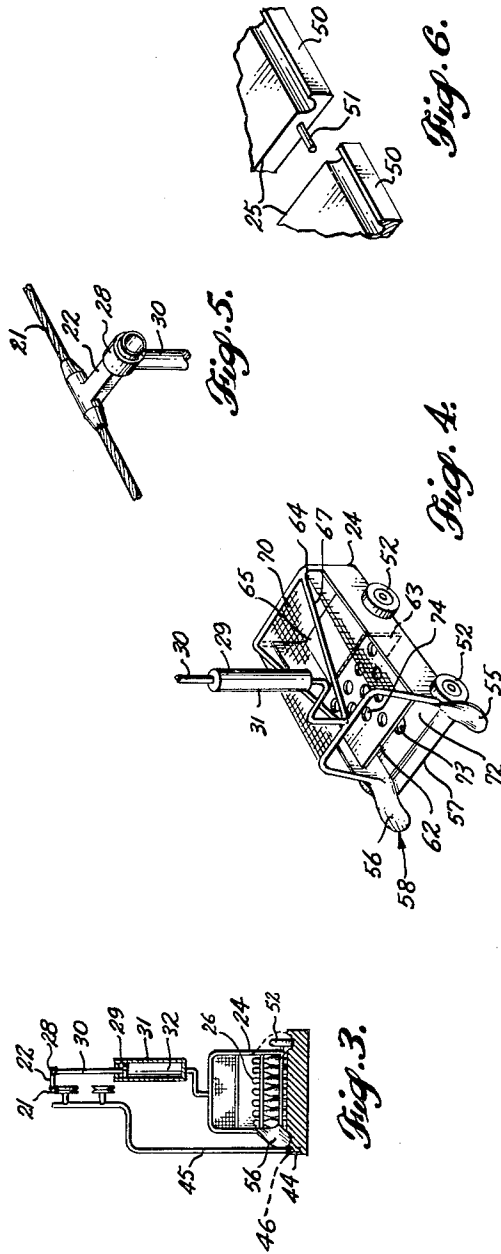

Fig. 3.

Fig. 4.

Fig. 5.

Fig. 6.

INVENTOR
JOAN P. FECHTER
BY *Roy Matterm Jr.*
ATTORNEY

1

2

3,220,728

ALLEY TRAVERSING MECHANISM FOR SETTING PINS AND FOR DELIVERING BALLS AND DOWNED PINS TO THE BOWLER

Joan Platt Fechter, 2012 Thorndyke Ave. W.,
Seattle, Wash.

Filed Dec. 17, 1962, Ser. No. 244,961
2 Claims. (Cl. 273-43)

This invention relates to the sport of bowling and more particularly to a method of operating a bowling lane and to bowling lane equipment, per se. A few years ago when bowling was becoming popular the game was played much as it is today but automation of the equipment was very limited. The participants remained at one end, only if they could secure the services of other persons to work down in the so-called pits to pick up the pins, restack them and return the ball. Of recent years, the persons, known as pin setters, required for doing this type of work in the pit area have largely been replaced by the use of automatic equipment. In most instances this equipment does a complete job. On occasions override controls, actuated by the bowler, are required to operate the automatic equipment, for example, to set ten pins after only one ball is thrown following a spare in the last frame of a line of bowling. This automatic equipment is known to be expensive to buy or to lease and it must be used indoors.

This invention is a new approach to the automation of bowling. Although the automation will be perhaps considered less sophisticated than what is currently being used in the large bowling lanes throughout the country, thorough consideration of this invention will indicate the bowling game may be played successfully by many bowlers following this new method under new surrounding conditions at lower cost. This is true because of the simplicity of the equipment involved and the direct participation of the bowler in the pin setting operation. The bowler, at the approach area will be arranging pins which are thereafter conveyed to the pin setting area and left standing ready for impact of the first ball. If the first ball leaves pins standing clear of all fallen pins a second ball may be sent on its way promptly. However, if the way is not clear the participating bowler by his remote means gathers the ball and all the pins returning them to the approach area. Then he resets the ones formerly left standing following the first impact of the ball and returns this number of pins to the pin setting area to be knocked down by the second ball thrown in the game frame. Following the rolling of the second ball all the pins remaining and the ball are returned to the approach area in preparation for playing a new frame, by the same bowler or another bowler, if league play is underway.

To summarize: the purpose of this invention is to enable self-service participation by a bowler at the approach area so he will be using lower cost equipment resulting in his lower cost participation in this fine sport. Yet the bowling equipment incorporates a sufficient degree of automation to maintain the bowler's interest in the sport and moreover to create an excellent financial status for the operator of such bowling lanes.

A brief description of the invention concerning both the method of operating the bowling lane equipment and the bowling lane equipment per se, comprises the following:

- (a) loading a lane traveling pin and ball conveyance with set bowling pins;
- (b) moving the lane traveling pin and ball conveyance to the pin setting area;
- (c) raising the lane traveling pin and ball conveyance to deposit the positioned pins;

- (d) lowering the lane traveling pin and ball conveyance behind the set pins;
- (e) returning the lane traveling pin and ball conveyance to the participating area following the delivery of a bowling ball and the intended striking of pins to collect both the ball and the pins;
- (f) resetting as many of the collected pins as required; and
- (g) removing the ball in preparation for again moving the lane traveling pin and ball conveyance to the pin setting area to continue this method of operating bowling game equipment.

The objectives of practicing this method and in the development of structural and mechanical aspects of the equipment are to provide:

- (1) a method of complete participation in the sport of bowling, wherein the bowler remains at the approach area at all times while serving himself;
- (2) structural and mechanical equipment suitable for installation indoors and outdoors;
- (3) relatively low initial and operating costs of structural and mechanical bowling lane equipment;
- (4) sectionalized structural and mechanical equipment for convenient transportation of the equipment from one location to another.

The invention, its purpose and objectives will be better understood as the following description is read and references are made to the drawings in which:

FIGURE 1 is a side elevation of the bowling lane equipment indicating by using dotted lines alternate positions of the pin and ball conveyance means;

FIGURE 2 is a top sectional view taken along line 2-2 of FIGURE 1;

FIGURE 3 is an across lane sectional view taken along line 3-3 of FIGURE 1;

FIGURE 4 is a perspective view of the pin and ball conveyance means;

FIGURE 5 is a perspective view of the attachment means joining the pin and ball conveyance means to the powered drive system; and

FIGURE 6 is a perspective view of an embodiment of the lane structure showing an assembly joint between structural bowling lane sections.

The invention described in this application concerns a method of bowling and equipment used in bowling which will give the participant an opportunity of enjoying the sport at lower cost and at locations now thought to be financially infeasible. Although the participants are relied upon to do some of the pin setting, nevertheless, the circumstances under which this is done still permits rapid play of the game on a basis comparable to a present day highly automated indoor bowling lane.

The equipment is designed in accordance with regulation bowling sizes and the game need not be changed in any respect. However, the dimensions could be changed proportionally making this method and equipment satisfactory for use by small children, juniors and others at schools and recreation centers, etc.

The method centers upon the participant both throwing the bowling ball and presetting pins at the approach area. This can be done for a conveyance is used which travels back and forth on the lane, first performing the pin setting function and thereafter collecting pins and bowling balls. The conveyance is powered and controlled to maintain maximum speed possible between its end points of operation. There is means on the conveyance in which to set the pins and hold them in this relative position until they have reached their place of position prior to the impact of the bowling ball. Subsequently, this conveying means must be placed where it will collect flying pins and the rolling ball in a positive manner.

Thereafter, upon its return trip, picking up straggling pins, the conveyance completely returns all the pins and bowling balls to the approach area.

This general operation requires not only horizontal movements of this conveying means, but likewise establishes the requirement that either the conveyance means in its entirety or a pin setting portion thereof must be raised above the pins at the pin setting area. Thereafter the conveyance means in its entirety must be lowered when behind the pin setting area in the recovery position or if only the pin setting portion is raised, it must be lowered from its raised position during the return motion of the conveyance means. On its return, the conveyance means remains immediately adjacent to the bowling lane ball surface and the contoured surface of the gutters so all the pins and ball or balls will be gathered into the conveying means and returned to the bowler at the approach area.

One embodiment 20 of the invention is shown in the FIGURES 1 through 5. An overhead closed loop cable run 21 is provided and a mounting pivot structure 22 is spliced into this cable run 21. From this pivot structure 22 the conveying means 24 is suspended remaining in contact with the lane throughout most of its travel. The exception occurs at the pin setting area where the cable run raises lifting the pivot structure and consequently the conveying means 24, also called the pin setting, pin and ball recovery means 24 above the lane 25, clearing the deposited pins 26 quickly so the pins 26 remain in striking position on the lane 25. Immediately, thereafter the loop cable run 21 lowers returning the pin setting, pin and ball recovery means 24 to its capture position by the set pins. On the return run, the lower elevation cable in traveling moves the pin setting, pin and ball recovery means 24 back to the approach area 27.

To accommodate the changes in elevation of the cable run 21 over the lane, the connecting or attachment means 28 between the pivot structure or mounting 22 and the pin setting, pin and ball recovery means 24 includes an extendable portion 29 comprising a telescoping piston 30, cylinder 31, assembly 29 which is filled with fluid 32 serving as a dampening means 32. The extension of this assembly 29, however, is kept within limits so at the pin setting area 33 the pin setting, pin and ball recovery means 24 will be abruptly raised clear of the pins 26 following the substantially elevated cable run portion 34.

In keeping with the objective of having the bowler be self-sufficient, the power means 36 for the cable run 21 and the controls 37 to start and stop its motion are all located at the approach area 27. In addition, an overhead mirror 38 is provided on stanchion 39 in the pin setting area 33 giving the bowler an additional line of sight to determine pin locations noting those resting directly behind others before rolling for the second time.

The lane traveling, pin and ball conveyance 24 used for pin setting, pin and ball recovery purposes is shown designed for a monorail type suspension; the rail in this case, however, being the moving cable 21 supported throughout by pulley wheels 41. One like wheel 42 is powered at the approach area 27 by the motor drive 36.

One side 44 of the lane 25 is equipped with vertical stanchions 45 to support this cable run 21 throughout the lane 25. Each one of the stanchions 45 is removably placed in an insert 46 in the basic lane structure 25. This arrangement establishes the portability of the drive means 48. In addition, to increase the portability, the lane in its entirety is formed of sections, as indicated by FIGURE 6 which shows two such sections 50 separated apart exposing one of the guide pins 51.

The immediate structure of the lane traveling pin and ball conveyance means 24, in addition to the description mentioned previously, includes a funnel volume that will be substantially captive of all flying pins and rolling balls. Ahead of the wheels 52 or low friction means 52 which are guided in the gutters 54 or the alleyways

54 on either side of the lane 25, there are scoop like approaches 55, 56 which closely fit the gutter structure 54. These scoops 55, 56 are joined by an inclined member 57 which closely approaches the ball throwing lane surface 25. By using this scoop-inclined structure 58 all the thrown balls 60 will be directed into the lane conveyance means 24. The thrown balls 60 pass below the upper pin setting jig 62 traveling to the rear of the conveying means 24, pushing a hinged door panel 63 out of the way, proceeding on to hit the back wall 64 of the conveying means 24 and remaining in this ball collective area 65 because the pivoting door 63 closes behind the ball 60 and does not swing in the opposite rotative direction. The immediately overhead structure 67, used to support the conveying means 24 and joined to the overhead attachment means 28, is designed also to supplement the captive pins and ball structure 68 of the conveying means 24 by including a surrounding heavy screen 70 or other structural material 70 to stop all flying pins 26, resulting in their collection within the conveying means 24.

Throughout the conveying means 24 is a complete floor 72 having pinholes 73 in direct alignment with those pinholes 74 above in the top pin setting jig 62. At the approach area the bowler inserts the pins 26 down through these paired and aligned holes 73, 74. The pins thereafter rest on the bowling lane 25 surface and are carried in this position semi-supported by the lane structure 25 itself to their place of setting.

When several lanes are arranged side by side the high lane end abutment 75 is wrapped around (not shown) the pin setting and striking location to form an additional pin capture means. The equipment is operable with a coin machine increasing its self service advantages.

What is claimed is:

1. Bowling game equipment operable by a bowler at his playing position, comprising:

(a) a bowling lane structure having a uniform and constant elevation surface extending throughout its entire length except for gutter alleyways along each side which serve both as collective channels for mis-directed balls and directive guides for the lane movement of a pin setting, pin collection, and ball retrieval device;

(b) a pin setting, pin and ball recovery device having a body, bowling pin locating supports in the front of the body, ball and pin collecting ramps across the front of the body, ball and pin collecting bin in the rear of the body, a one way pivoting divider between the bowling pin locating supports and the ball and pin collecting bin to allow the ball and pins to enter but not leave the bin, an overhead frame on the body, ball and pin restrictive structure on the overhead frame, an upright automatic adjusting connecting structure on the overhead frame, a pivotal connection assembly on the top of the automatic adjusting connecting structure, and running wheels on the body arranged to follow the gutter alley ways;

(c) a powered conveyor-driving assembly having spaced multiple vertical stanchions extending up from a side of the bowling lane structure, a motor driven, multiple pulley, continuous loop driven cable assembly attached to top portions of the vertical stanchions, the delivery cable run moving toward the pin setting position being level until the pin setting location is reached, whereupon this delivery cable run abruptly raises in elevation over the pin setting location to raise the entire pin setting, pin and ball recovery device above the bowling lane structure to clear the first conveyed and then deposited bowling pins, and then the cable run, after dropping, becoming the lower return cable run, a cable connection on the continuous loop driven cable assembly for pivotally receiving the pivotal connection assembly on the top of the automatic adjusting connecting structure, the latter serving to compensate for the

elevation variations between the delivery and return cable runs except at the pin setting location; and
 (d) a control operable by the bowler at his playing position to start and stop the powered conveyor-driving assembly. 5
 2. Bowling game equipment operable by a bowler at his playing position, comprising:
 (a) a bowling lane structure having gutter alley ways and a uniform constant elevation surface between the gutter alley ways and from end to end of the lane structure; 10
 (b) a pin setting, pin and ball recovery device having a body which non-movably supports pin setting guides, ball and pin collecting ramps and bin, an overhead upright changeable length pivotal connection assembly, and an underneath wheel assembly to be guided by the gutter alley ways; 15
 (c) a powered conveyor-driving assembly having lane supported upright stanchions in turn supporting an overhead delivery pulley-cable run moving toward the pin setting area where the cable run abruptly raises over the pin setting area and thereafter drops to a return pulley-cable run moving toward the bowler at an elevation lower than the delivery pulley-cable run, and a cable connection on the cable which is the continuous cable extending throughout the 20 25

delivery and return pulley-cable runs for pivotally receiving the overhead upright changeable length pivotal connection assembly of the pin setting, pin and ball recovery device, the changeable length compensating for elevation variations between delivery and return cable runs but not for the abrupt rise of the delivery cable run over the pin setting location; and
 (d) a motor and its start-stop control connected to the powered conveyor-driving assembly and placed for operation by the bowler at his playing position.

References Cited by the Examiner

UNITED STATES PATENTS

1,581,378	4/1926	Bishop	-----	273-42
2,380,337	7/1945	Sebell	-----	273-43
2,390,224	12/1945	Sams	-----	273-47
2,541,583	2/1951	Hayden	-----	273-51
2,990,178	6/1961	Whang	-----	273-54

FOREIGN PATENTS

70,079 8/1893 Germany.

RICHARD C. PINKHAM, *Primary Examiner.*

25 DELBERT B. LOWE, ANTON O. OECHSLE,
Examiners.