

Fig. 1

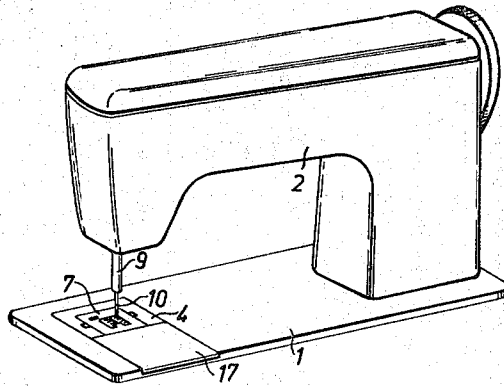

Fig. 2

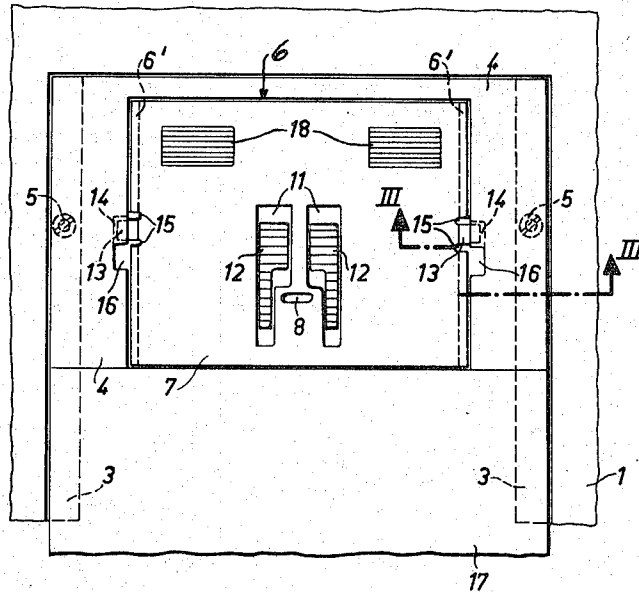
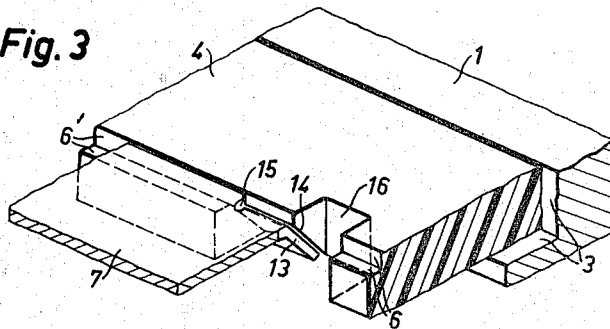

Fig. 3



INVENTOR.
BY GÜNTER MEIER
MARL RATH
ATTORNEY

SEWING MACHINE WITH REMOVABLE STITCHING PLATE

The present invention relates to sewing machines, more particularly to a removable stitching plate mounted within an opening of the cloth plate or sewing table of a machine between the reciprocating needle and lower stitch-forming tools (loop-taker), said plate being provided in a known manner with apertures for the passage of the needle and work feed dog during operation.

As is well known, sewing dust or particles given off by the sewing material accumulate below the stitching plate during operation and must be removed from time to time, to ensure a disturbance free operation of the lower stitch-forming tools (loop-taker) mounted underneath the stitching plate. For this purpose, it is customary to removably mount the stitching plate upon the sewing table.

According to conventional practice, the stitching plate is secured by the aid of a pair of countersunk screws. This manner of mounting has been found impractical, because it requires a special tool (screwdriver) for the tightening and loosening of the screws, while the repeated unscrewing and reinsertion of the screws may lead to an early damage of the screw threads and the screwdriver slits in the heads thereof. As a consequence, the screws may no longer properly fit in the depressions of the stitching plate, whereby to result in damage to the work or sewing material being operated on, as well as in other defects and drawbacks. Besides, screwing and unscrewing of the plates is both time-consuming and troublesome to the ordinary sewing machine user or operator.

In order to obviate the foregoing disadvantages, it has already been proposed to provide the stitching plate with special projections adapted to resiliently interlock with cooperating projections of the cloth plate or stitching table against the action of intervening locking springs. This manner of resiliently supporting the stitching plate involves the danger of vibration of the plates during the higher sewing speeds of the machine. Besides, difficulties are experienced in withdrawing the plates from the operative to the inoperative position against the action of the locking springs.

It has furthermore been proposed, in an effort to overcome the previous difficulties, to provide a supporting ledge at one end of the stitching plate adapted to engage a slot in the cloth plate or sewing table. The opposite end of the plate is secured by means of a pivoted locking spring or clasp operated by an eccentric control. Such arrangements are relatively bulky and unsuited for certain types of machines, while having the further drawback that the locking element must be disposed underneath the stitching plate or sewing table.

Accordingly, an important object of the present invention is the provision of an improved removable stitching plate for sewing machines of the referred to type which may be firmly locked in the operative position without requiring any special securing means; which requires no special tools for its removal and mounting; which can be removed and reinserted instantly and readily by mounting means accessible from the upper side of the sewing table; and which is both simple in construction and suitable for ready structural incorporation in conventional sewing machines.

The invention, both as the foregoing and ancillary objects as well as novel aspects thereof, will be better understood from the following detailed description of a preferred practical embodiment, taken in conjunction with the accompanying drawing forming part of this specification and in which:

FIG. 1 is a perspective view of a conventional sewing machine embodying the improved stitching plate, shown in its operative position and constructed in accordance with the principles of the invention;

FIG. 2 is a more detailed plan view to an enlarged scale of the stitching plate and mounting assembly according to the invention; and

FIG. 3 is a fragmentary perspective view more clearly showing the stitching plate in the locked or operative position.

Like reference numerals denote like parts in the different views of the drawing.

With the foregoing objects in view, the invention, according to one of its aspects, involves generally the provision of a stitching plate for a sewing machine of the referred to type slidably supported, between an inoperative and an operative position and flush with the cloth plate or sewing table of the machine, by a pair of shoulders upon the opposite edges of a rectangular opening of said cloth plate or table. In order to removably support the stitching plate, the same is provided with mounting lugs projecting from the opposite edges thereof adjoining said shoulders, said lugs being adapted to loosely fit, in the inoperative position of the plate, suitable recesses in the edges of said opening, to enable easy insertion and withdrawal, and said lugs adapted, in the operative position of said plate, to resiliently engage or lock with corresponding ledges or abutments of said table disposed within said edges and adjoining said recesses.

According to a preferred embodiment, the mounting lugs in the operative position of the stitching plate are displaced from the adjoining recesses by a distance equal to the width of the lugs, whereby to result in a minimum distance or movement between the operative and inoperative positions of the plate. The stitching plate is furthermore provided in a known manner with a suitable aperture, to enable the passage of the needle in its operative position, and where a four-motion feed dog is provided, a further oblong aperture being having a length in excess of the feed stroke or total advance movement of said dog, is provided, to enable ready passage of the dog during operation. In the latter case and the preferred embodiment mentioned, the difference between the length of the oblong aperture and the length of the feed dog is advantageously in excess of the width of the mounting lugs, to ensure ready operation of the stitching plate, in the starting position of the quadrilateral movement of the feed dog, substantially without obstruction by said dog.

According to an especially advantageous construction, the lugs project from the edges of the stitching plate at an angle in the downward direction and the cloth plate is formed with corresponding inclined abutment surfaces or ledges, to result in a firm resilient yet easily releasable locking engagement in the operative position of the plate, in a manner as will become further apparent as the description proceeds in reference to the drawing.

According to an improved feature, to minimize operating noise, the stitching plate is removably mounted in a separate intermediate or damping plate of elastic material which is, in turn, secured in an opening of the sewing table or cloth plate of the machine, and the stitching plate may be further locked or arrested in its operative position by means of an auxiliary locking plate or slide mounted in said table.

The mounting of the stitching plate in a separate intermediate supporting plate, being secured to an opening in the sewing table with a sufficient play or clearance, has the added advantage of enabling a ready alignment of the plate with the mean position of the needle. This in turn enables the parts to be fabricated with less stringent tolerance requirements, compared with conventional practice and manufacturing methods.

Referring more particularly to the drawing, FIG. 1, the numeral 1 denotes the cloth plate or sewing table of a conventional sewing machine from which extends the overhanging arm 2 terminating in a head within which is mounted the reciprocating needle bar 9 carrying a needle 10. Item 4 denotes an intermediate supporting plate of elastic material, such as a suitable synthetic plastic, being supported by the ledges 3 of an opening in the table 1 and secured by means of screws 5, FIG. 2, and serving in turn as a support for the stitching plate 7 of the machine slidably mounted in a rectangular opening 6 of the plate 4, FIGS. 2 and 3. As more clearly seen from the latter, two opposite edges of the U-shaped opening or recess 6 are provided with throughgoing shoulders 6' slidably supporting the plate 7 between an operative and an inoperative or retracted position, in cooperation with a slide 17 mounted flush with the table 1 and forming with the recess 6 a rectangular opening of variable width in a manner as will become further apparent as the description proceeds.

As further shown by FIG. 2, the stitching plate 7 has a first aperture 8, to enable passage of the needle 10 during operation for cooperation with the lower stitch-forming tools (not shown), to produce lockstitches in the work being operated on in a manner well known. Where a lower feed dog 12 is provided, operated according to the well known four-motion principle and mounted below the plate 7, the latter has a further opening, or pair of openings, 11, to enable passage of the dog during operation.

The stitching plate 7, according to the improved construction, has a pair of outwardly projecting mounting lugs 13 disposed on the opposite sides thereof adjoining said shoulders, said lugs adapted to resiliently engage, in the operative position of the plate shown in the drawing, corresponding ledges or abutments 14 in the opening 6 of the intermediate plate 4, whereby to firmly resiliently lock the stitching plate in the operative position with the cloth plate, or intermediate plate 7 in the example shown, by virtue of the inherent elasticity of the materials.

For manufacturing reasons, the stitching plate 7 is formed with cuts 15 extending laterally of the lugs 13 and, in order to enable a ready removal from and reinsertion in the intermediate plate 4, the opening 6 in the plate 4 is formed with lateral recesses 16 in the opposite edges thereof adjoining the lugs 13, said lugs being displaced, in the operative position of the plate, from the recesses 16 by a predetermined distance being less than the difference between the length of the aperture 11 and the length of the feed dog 12, for the purpose as pointed out hereinbefore. The difference between the length of the aperture 11 and the length of the dog 12 slightly exceeds the maximum operating stroke of the dog in accordance with conventional practice. A cover plate 17 sliding upon the ledges of the opening serves to lock plate 7 in the operative position.

According to an especially advantageous construction, the stroke or displacement of the plate 7 from its inoperative position to its operative position, and vice versa, or maximum displacement of the lugs 13 from the recesses 16 in the operative position of the plate, is equal to the width of the lugs, whereby to ensure a maximum locking effect with a minimum operating stroke or displacement. In other words, the width of the recesses 16 is slightly in excess of the width of the lugs 13, whereby to provide a loose fit of the lugs within the recesses in the inoperative position of the plate 7.

As can be clearly seen, the plate 7 may be removed and reinserted without any special tools by simply displacing the same from its operative position shown to the inoperative position with the lugs 13 loosely fitting the recesses 16. Reinsertion is then effected in reverse sequence, as will be further described in the following.

According to a modified construction, the lugs 13 may be offset, to extend in a direction parallel to the plane of the plate 7 and to interlock with corresponding ledges upon the edges of the opening 6 in the plate 4. Besides, instead of arranging the lugs 13 on the opposite edges of the plate 7, they may be disposed on the opposite sides of the apertures 11 for cooperation with suitable complementary locking elements or abutments extending from the intermediate plate 4 or table 1, respectively.

In use, in order to effect the removal of the stitching plate 7 from its operative position shown, the sewing machine is arrested with the needle in the up-position corresponding to the feed dog being in the starting position of its quadrilateral feed movement, that is, a position adjoining the lower edge of the apertures 11. This position is most favorable for the safe removal and reinsertion of the stitching plate. In order to remove the plate, the locking slide 17 is at first sufficiently withdrawn in the rearward direction, whereupon plate 7 is displaced in the same direction until the lugs 13 are positioned in the recesses 16, this operation being facilitated by the roughened gripping surfaces 18 upon the upper surface of the stitching plate. The latter may then be removed by withdrawal in the upward direction, to provide ready access to the lower stitch-forming tools for cleaning and the carrying out of adjustments or repairs.

Reinsertion of the stitching plate 7 is effected in reverse sequence by at first applying the same to the opening 6 with the lugs 13 loosely fitting the recesses 16 and subsequently displacing it in the forward direction until the lugs engage the abutments 14, to firmly lock the plate with the table 1 or intermediate plate 4, respectively.

In the foregoing the invention has been described in reference to a specific exemplary device. It will be understood, however, that variations and modifications, as well as the substitution of equivalent parts and elements for those shown herein for illustration, may be made without departing from the broader scope and spirit of the invention. The specification and drawing are accordingly to be regarded in an illustrative rather than in a restrictive sense.

I claim:

1. A sewing machine comprising in combination:

1. a sewing table consisting at least in part of resilient material having a U-shaped opening formed therein and a slide mounted flush with said table and having an edge forming a rectangular opening with said U-shaped opening, the opposite edges of said U-shaped opening being provided with recesses;
2. an overhanging arm extending from said table and terminating in a head carrying a reciprocatory needle;
3. shoulders extending along the opposite edges of said U-shaped opening;
4. a removable stitching plate slidably supported by said shoulders flush with said table, to enable operation thereof between an operative and a retracted position;
5. a four-motion feed dog below said plate;
6. said stitching plate having a first aperture, to enable passage of said needle, and a second aperture, to enable passage of said feed dog, during a stitching cycle in the operative position of said plate;
7. a pair of mounting lugs extending from the opposite edges of said plate adjoining said shoulders;
8. a pair of abutments upon said table adjoining said recesses and said shoulders; and
9. said lugs loosely fitting said recesses, in the retracted position of said plate and resiliently locking, by virtue of the resiliency of the material, with said abutments in the operative position of said plate.

2. In a sewing machine as claimed in claim 1, said recesses having a width slightly in excess of the width of said lugs, and said lugs being displaced, in the operative position of said plate, from the adjoining recesses by a distance substantially equaling the width of said lugs.

3. In a sewing machine as claimed in claim 1, said second aperture being parallel to said shoulders and having a length in excess of the length of said dog, and the stroke of displacement of said stitching plate between its operative and its retracted positions being less than the difference between the length of said second aperture and the length of said dog.

4. In a sewing machine as claimed in claim 1, said second aperture being parallel to said shoulders and having a length in excess of the length of said dog, said recesses having a width slightly in excess of the width of said lugs, said lugs being displaced in the operative position of said stitching plate, from the adjoining recesses by a distance substantially equal to the width thereof, and the width of said lugs being less than the difference between the length of said second aperture and the length of said dog.

5. In a sewing machine as claimed in claim 1, wherein said part of resilient material is an intermediate plate mounted in said table.

6. In a sewing machine as claimed in claim 1, wherein said lugs and abutments extend in a downwardly and an outwardly direction from said stitching plate and are in resilient locking engagement in the operative position of said plate.

7. A sewing machine comprising in combination:

1. a sewing table consisting at least in part of resilient material and having a U-shaped opening and a slide mounted flush with said table and having an edge forming a rectangular opening of variable width with said U-

5

6

- shaped opening, the opposite edges of said U-shaped opening provided with recesses;
- 2. an overhanging arm extending from said table and terminating in a head carrying a reciprocatory needle;
- 3. shoulders extending along the opposite edges of said first U-shaped opening;
- 4. a stitching plate slidably supported by said shoulders flush with said table, to enable operation thereof between an operative and a retracted position, said plate having an aperture to enable passage of said needle in the operative position,
- 5. a pair of mounting lugs extending from the opposite edges of said plate adjoining said shoulders;
- 6. a pair of abutments upon said table adjoining said recesses and said shoulders; and

- 7. said lugs loosely fitting said recesses in the retracted position of said plate and resiliently locking, by virtue of the resiliency of the materials, with said abutments in the operative position of said plate.
- 8. In a sewing machine as claimed in claim 7, wherein said recesses have a width slightly in excess of the width of said lugs and said lugs are displaced, in the operative position of said plate, from the adjoining recesses by a distance substantially equal to the width thereof.
- 9. In a sewing machine as claimed in claim 7, wherein said lugs extend in a downward direction from said plate and said table is formed with oblique abutments resiliently engaged by said lugs in the operative position of said plate.

15

20

25

30

35

40

45

50

55

60

65

70

75