

(19)



(11)

EP 1 973 196 A1

(12)

EUROPEAN PATENT APPLICATION

(43) Date of publication:

24.09.2008 Bulletin 2008/39

(51) Int Cl.:

H01Q 7/00 (2006.01)

H01Q 7/06 (2006.01)

H01Q 9/42 (2006.01)

H01Q 21/28 (2006.01)

H01Q 1/24 (2006.01)

(21) Application number: **07445011.5**

(22) Date of filing: **22.03.2007**

(84) Designated Contracting States:

**AT BE BG CH CY CZ DE DK EE ES FI FR GB GR
HU IE IS IT LI LT LU LV MC MT NL PL PT RO SE
SI SK TR**

Designated Extension States:

AL BA HR MK RS

(72) Inventors:

• **Kaikkonen, Andrei**

164 71 Kista (SE)

• **Lindberg, Peter**

752 29 Uppsala (SE)

(71) Applicant: **Laird Technologies AB**

164 22 Kista (SE)

(74) Representative: **Estreen, Lars J.F. et al**

Kransell & Wennborg KB

P.O. Box 27834

115 93 Stockholm (SE)

(54) **Antenna device and portable radio communication device comprising such antenna device**

(57) An antenna device for a portable radio communication device, preferably for the FM frequency range, comprises a radiating element (10), and an amplifier

stage. By providing the radiating element as a half-loop radiating element, the noise figure is essentially flat across the entire operating frequency range, giving adequate signal to noise ratio despite gain variances.

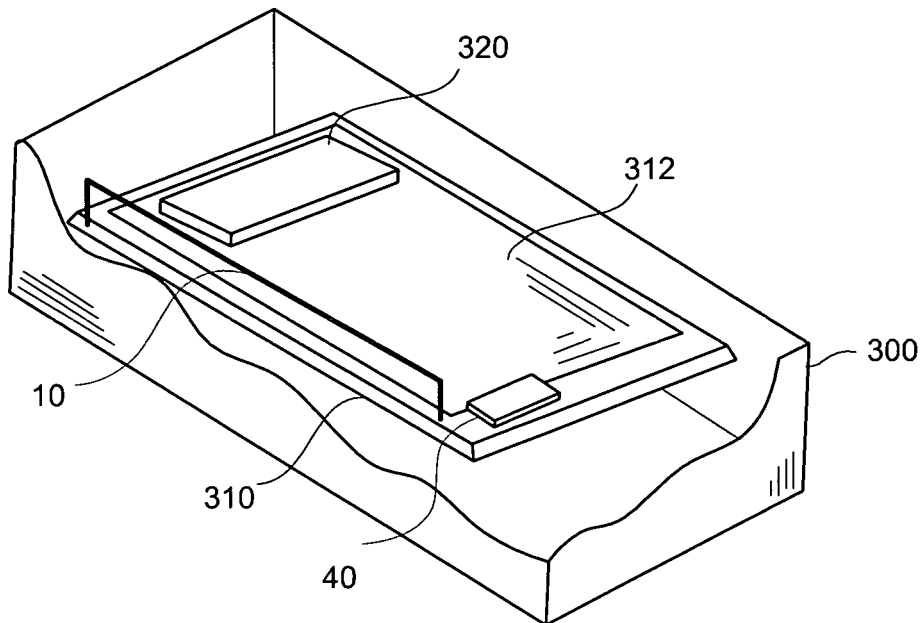

Fig. 6

EP 1 973 196 A1

DescriptionFIELD OF INVENTION

[0001] The present invention relates generally to antenna devices and more particularly to an antenna device for use in a radio communication device, such as a mobile phone, which is adapted for radio signals having a relatively low frequency, such as radio signals in the FM band.

BACKGROUND

[0002] Internal antennas have been used for some time in portable radio communication devices. There are a number of advantages connected with using internal antennas, of which can be mentioned that they are small and light, making them suitable for applications wherein size and weight are of importance, such as in mobile phones.

[0003] However, the application of internal antennas in a mobile phone puts some constraints on the configuration of the antenna element. In particular, in a portable radio communication device the space for an internal antenna arrangement is limited. These constraints may make it difficult to find a configuration of the antenna that provides for a wide operating band. This is especially true for antennas intended for use with radio signals of relatively low frequencies as the desired physical length of such antennas are large compared to antennas operating with relatively high frequencies.

[0004] One specific application operating in a relatively low frequency band is the FM radio application. The FM band is defined as frequencies between 88-108 MHz in Europe or between 76-110 MHz in the USA. Prior art conventional antenna configurations, such as loop antennas or monopole antennas, fitted within the casing of a portable radio communication device will result in unsatisfactory operation in that the antenna either has too bad performance over a sufficiently wide frequency band or sufficient performance over a too narrow frequency band.

[0005] Instead, a conventional FM antenna for portable radio communication devices is provided in the headset wire connected to the communication device. This configuration with a relatively long wire permits an antenna length that is sufficient also for low frequency applications. However, if no external antenna is permitted this solution is obviously not feasible.

[0006] Another problem is that in case a second antenna, such as a GSM antenna, is provided in the same communication device as the FM antenna, this second antenna interferes with the operation of the FM antenna.

SUMMARY OF THE INVENTION

[0007] An object of the present invention is to provide an internal antenna device for use in a portable radio

communication device, which operates with sufficient performance throughout a frequency band having a relatively low frequency, such as the FM radio band.

[0008] The invention is based on the realization that an active internal antenna can be configured as a half-loop antenna.

[0009] According to the present invention there is provided an antenna device for a portable radio communication device adapted for receiving radio signals in at least a first operating frequency band, said antenna device comprising a radiating element comprising a feeding portion, and an amplifier stage connected to the feeding portion of the radiating element and connectable to a receiver device for radio signals, the antenna device being characterized in that the radiating element is a half-loop radiating element.

[0010] A portable radio communication device comprising such an antenna device is also provided.

[0011] The antenna device according to the invention provides operation with sufficient performance throughout a frequency band having a relatively low frequency, such as the FM radio band. By using a half-loop antenna, it has been found that the noise figure is essentially flat across the entire operating frequency range, giving adequate signal to noise ratio despite gain variances.

[0012] In a preferred embodiment, the antenna device comprises a printed circuit board provided with a ground plane, wherein the feeding portion of the radiating element is provided at or close to one end of the printed circuit board and the end of the radiating element opposite to the feeding portion is grounded at or close to the other end of the printed circuit board. In this way the area of the printed circuit board is used to a maximum.

[0013] A capacitor is preferably connected between the radiating element and ground relatively close to the feeding portion of the radiating element. This capacitor, which preferably has a value of 10-40 pF, increases source resistance seen by the transistor of the amplifier, thus matching noise and increasing stability. Also, since the radiating element is essentially grounded at or close to the ends of the printed circuit board where the E field of a primary antenna device, such as a GSM antenna, is large, cross-talk from this primary antenna is minimized.

[0014] Further preferred embodiments are defined in the dependent claims.

BRIEF DESCRIPTION OF DRAWINGS

[0015] The invention is now described, by way of example, with reference to the accompanying drawings, in which:

FIG. 1 is a schematic diagram showing an antenna device according to the invention connected to an FM receiver circuit;

FIG. 2 is a diagram showing in more detail a first embodiment of an antenna device according to the

invention;

FIG. 3 is a diagram showing in more detail a second embodiment of an antenna device according to the invention;

FIG. 4 is a schematic view of a radiating element configuration of an antenna device according to the invention;

FIG. 5 is a schematic view of a multi-turn radiating element configuration of an antenna device according to the invention;

FIG. 6 is a perspective partially cut-away view of an antenna device according to the invention mounted in a portable radio communication device; and

FIG. 7 is a perspective partially cut-away view of an alternative antenna device according to the invention mounted in a portable radio communication device.

DETAILED DESCRIPTION OF THE INVENTION

[0016] In the following, a detailed description of preferred embodiments of an antenna device and a portable radio communication device according to the invention will be given.

[0017] In the following description and claims, the term radiating element is used. It is to be understood that this term is intended to cover electrically conductive elements arranged for receiving and/or transmitting radio signals.

[0018] First with reference to FIG. 1, the general configuration of an antenna device 1 according to the invention is shown. It comprises a radiating element 10 in the form of a non-resonant piece of electrically conductive material. The radiating element is part of a half loop antenna, as will be described in detail below.

[0019] The radiating element has a feeding portion 11 connected to a shunt capacitor 20 arranged to resonate with the radiating element, amplifier input and an optional ESD protection circuit. The resonant frequency response acts as a band pass filter for signals in the operating frequency band. In the case of operation in the FM band, the pass band is between 88-108 MHz in Europe or between 76-110 MHz in the USA.

[0020] The function of the resonant frequency response further acts as ESD protection circuit, effectively blocking the major part of ESD pulse spectrum. The filter also eliminates or at least reduces interference from electro magnetic interference (EMI) signals and possibly signals from other antennas provided in the same radio communication device, such as cellular GSM antennas operating at frequencies well above the FM antenna.

[0021] An amplifier stage 30 is arranged after the shunt capacitor 20 for amplifying signals received by the radiating element 10.

[0022] Signals received and amplified by the antenna

device 1 are supplied to an FM receiver circuit 40, which could be a conventional circuit manufactured by Philips Semiconductors and sold under the name HVQFN40. The FM receiver circuit comprises an RF input 41, which is connected to the amplifier 30.

[0023] It is preferred that the shunt capacitor 20 and amplifier stage 30 are provided relatively close to the radiating element 10 in order to minimize parasitic effects and interference from external sources.

[0024] An implementation of the general idea expressed in FIG. 1 will now be described with reference to FIG. 2.

[0025] The amplifier stage 30 comprises a field effect transistor (FET) 31 with the gate connected to the shunt capacitor 20, the source connected directly to ground and the drain connectable to the input 41 of the FM receiver circuit 40. There is also a load resistor 32 connected between the drain of the transistor 31 and the feed voltage Vdd.

[0026] In order for the antenna device 1 to operate, the transistor preferably has a minimum noise figure below 1 dB and a gain above 15 dB in the operating frequency band. Also, it is preferred that the transistor has a noise resistance R_n of less than 10 Ohms in order to achieve highest possible signal reception quality for arbitrary antenna configurations. A further preferred characteristic of the transistor is that the input capacitance is low, preferably less than 3 pF, in order to obtain high input impedance.

[0027] An alternative implementation of the inventive idea in the form of a second embodiment will now be described with reference to FIG. 3. Like the above described first embodiment, this antenna device comprises a radiating element 10 having a feed portion 11, a shunt capacitance, and amplifier stage 30. However, in this second embodiment the shunt capacitance is adjustable, i.e., implemented as a so-called varactor 120, providing a controllable antenna device. Furthermore, the amplifier stage is a so-called cascode amplifier 130. This cascode amplifier comprises a field effect transistor 131 with the gate connected to the radiating element and shunt capacitance, the source connected directly to ground and the drain connected to the source of a second field effect transistor 133. The gate of the second transistor 133 is connected to ground via a capacitor 134. The drain of the second transistor 133 is connectable to the input 41 of the FM receiver circuit 40. There is also a load resistor 132 connected between the drain of the second transistor 133 and the feed voltage Vdd.

[0028] In this second embodiment, an FM transmitter circuit 140 is connected to the radiating element via a switch 141. This switch is necessary if the input impedance Z_{Tx} of the transmitter circuit is much lower, such as ten times lower than the input impedance Z_{Rx} of the amplifier 130 in front of the receiver circuit 40. However, this switch 141 can be omitted if the input impedance Z_{Tx} of the transmitter circuit is in the same order as the input impedance Z_{Rx} of the amplifier 130.

[0029] By providing a transmitter circuit connected to the radiating element 10, this radiating element can be shared and thus function for both transmission and reception. The transmitter circuit should preferably be connected to the radiating element approximately at feed portion 11.

[0030] General layouts of the radiating element of an antenna device according to the invention will now be described with reference to FIGs. 4 and 5. A printed circuit board (PCB) 310 is suitably arranged in a portable radio communication device (not shown in these figures). A ground plane 312 is provided on the PCB. A signal lead, corresponding to the above described amplifiers 30, 130, is provided on this PCB, which is preferably a multi-layer PCB. The radiating element 10, which is preferably a wire-shaped electrical conductor, is connected to the amplifier at the feed portion 11, preferably at or close to one end of the PCB. This conductor runs essentially parallel to and at a distance h from the PCB 310 for most of its length. The end of the conductor 10 opposite the end connected to the signal source is connected to the ground plane 312 provided on the PCB 310 at or close to the other end of the PCB. This means that the radiating element, which forms a half loop, takes advantage of as much space as possible since the loop area is important for the antennas performance.

[0031] A capacitor 20 is provided between the radiating element and ground relatively close to the feeding portion 11. This capacitor, which preferably has a value of 10-40 pF, increases the source resistance seen by the transistor of the amplifier, thus matching noise and increasing stability.

[0032] In an alternative embodiment, the conductor 10 is provided in more than one turn, in the example shown in FIG. 5 in two turns. The conductor of the first half loop is lead through a hole 314 in the PCB and to the lower side thereof. On the lower side, the conductor runs along the PCB, preferably in the form of a micro strip line 10a, from one end of the PCB to the other. The conductor is there lead through a second hole 316 in the PCB to the upper side thereof, along the PCB at a distance thereof, and is finally grounded at the second end of the PCB. In this way, the radiation resistance, being proportional to the number of loop turns squared, is increased, improving the performance of the antenna.

[0033] A ferrite inside the loop, schematically referenced 14 can be used with both the embodiment of Fig. 4 and the one of Fig. 6 in order to improve the performance of the antenna device.

[0034] A first preferred position of the antenna device according to the invention as described above with reference to FIGs. 1-3 will now be described with reference to FIG. 6, wherein the general outlines of the casing of a portable radio communication device 300, such as a mobile phone, is depicted. The casing is shown partially cut away so as to not obscure the position of the antenna device, which could be any of the devices described with reference to FIGS 1-3.

[0035] The PCB 310 is provided in the casing, having the circuits (not shown) conventionally found in a mobile phone. On the PCB there is also mounted the FM receiver circuit 40. In the upper portion of the casing there is provided an antenna radiating element 320 for receiving and transmitting RF signals for a cellular mobile phone system, such as a GSM system.

[0036] A battery package (not shown) is also provided towards the back of the casing 300.

[0037] The FM antenna radiating element 10 is preferably placed so that it is connected to the FM circuit at the end of the PCB opposite to the end where the radiating element 320 is provided. The radiating element then runs along a long side of the PCB until it reaches the other end of the PCB, where it is grounded to the ground plane 312 provided on the PCB 310.

[0038] In order to make the antenna device less sensitive to orientation, the radiating element 10 can be provided so that it also runs along a short side of the PCB, see Fig. 6, before it is grounded to the ground plane 312 provided on the PCB.

[0039] Preferred embodiments of an antenna device according to the invention have been described. However, the person skilled in the art realizes that these can be varied within the scope of the appended claims without departing from the inventive idea.

[0040] It is realized that the shape and size of the antenna device according to the invention can be varied within the scope defined by the appended claims. Thus, the exact antenna configurations can be varied so as to correspond to the shape of the radio communication device, desired performance etc.

[0041] The above-described embodiments of an antenna device according to the invention have been described as antenna devices adapted for reception of radio signals in the FM frequency band. However, other applications are also possible, such as use for digital video broad-casting (DVB) signals in the frequency range of about 400-800 MHz.

[0042] Although an antenna device for a portable radio communication device has been described with reference to its use in a mobile phone, it will be appreciated that the inventive idea is also applicable to other portable radio communication devices, also devices that are portable but primarily intended for stationary use. Examples thereof could be small clocks, such as travel alarm clocks, TV receivers, or game consoles. Yet a possible application of the antenna device according to the invention is in personal digital assistants (PDAs), MP3 and CD players, FM radio receivers, and laptop computers. A further application is in cars. Thus, the term portable radio communication device should be construed in a broad sense.

[0043] The embodiments described above with reference to FIGs. 6 and 7 include a GSM antenna. It will be appreciated that this could be substituted for a different antenna as long as its operating frequency is well above that of the lower frequency band, such as the FM band. A second antenna can also be omitted.

[0044] A FET has been described as the preferred transistor type. It will be realized that other types of transistors, such as hetero-junction bipolar transistors (HBT), can be used as well.

[0045] It will be appreciated that the Tx part can be implemented also in the first embodiment shown in Fig. 2. It is likewise appreciated that the capacitor 20 of the first embodiment can be replaced by a varactor.

Claims

1. An antenna device for a portable radio communication device adapted for receiving radio signals in at least a first operating frequency band, said antenna device comprising

- a radiating element (10) comprising a feeding portion (11; 111), and
- an amplifier stage (30) connected to the feeding portion of the radiating element and connectable to a receiver device for radio signals,

characterized in that

- the radiating element is a half-loop radiating element.

2. The antenna device according to claim 1, further comprising a ground plane (312), wherein the feeding portion (11) of the radiating element is provided at or close to one end of the ground plane and the end of the radiating element opposite to the feeding portion is grounded at or close to the other end of the ground plane.

3. The antenna device according to claim 2, comprising a capacitor (20; 120) connected between the radiating element and the ground plane (312) relatively close to the feeding portion (11).

4. The antenna device according to claim 3, wherein the capacitor (20; 120) has a value of 10-40 pF.

5. The antenna device according to claim 3 or 4, wherein the capacitor (120) has adjustable capacitance value.

6. The antenna device according to any of claims 1-5, wherein the ground plane (312) is provided on a printed circuit board (310), and wherein the radiating element (10) runs along a long side of the printed circuit board.

7. The antenna device according to claim 6, wherein the radiating element (10) additionally runs along a short side of the printed circuit board (310).

8. The antenna device according to any of claims 1-7, wherein the radiating element (10) comprises a plurality of turns.

9. The antenna device according to claim 8, wherein part of the radiating element (10) is partly provided as a micro strip line (10a).

10. The antenna device according to any of claims 1-9, comprising a ferrite (14) inside the half-loop of the radiating element.

11. The antenna device according to any of claims 1-10, wherein the radiating element (10) is connectable to a transmitter circuit (40).

12. The antenna device according to any of claims 1-11, wherein the first operating frequency band is the FM band.

13. A portable radio communication device (300) comprising an antenna device according to claim 1.

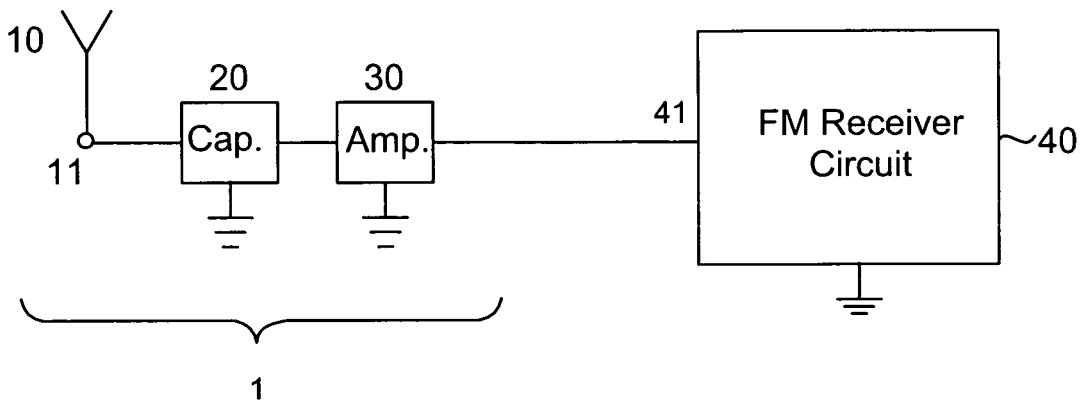

Fig. 1

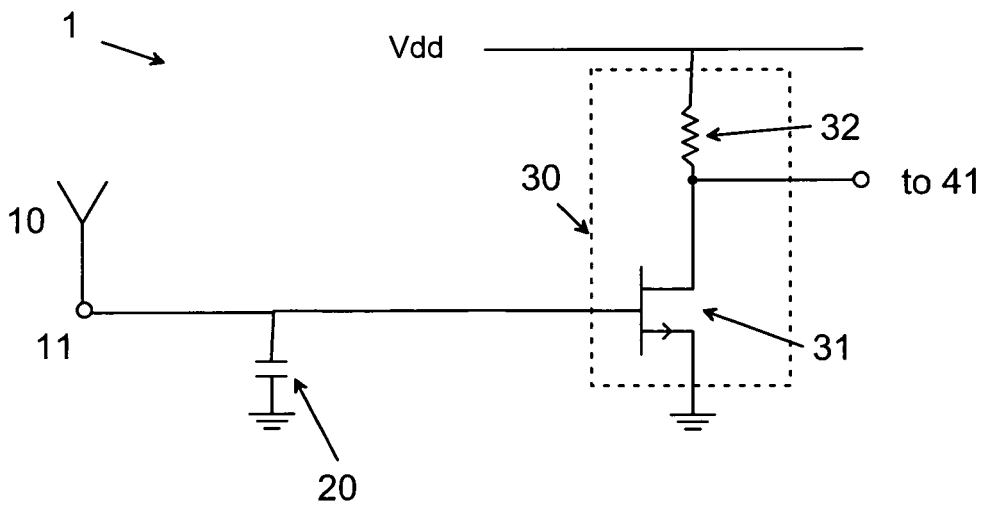

Fig. 2

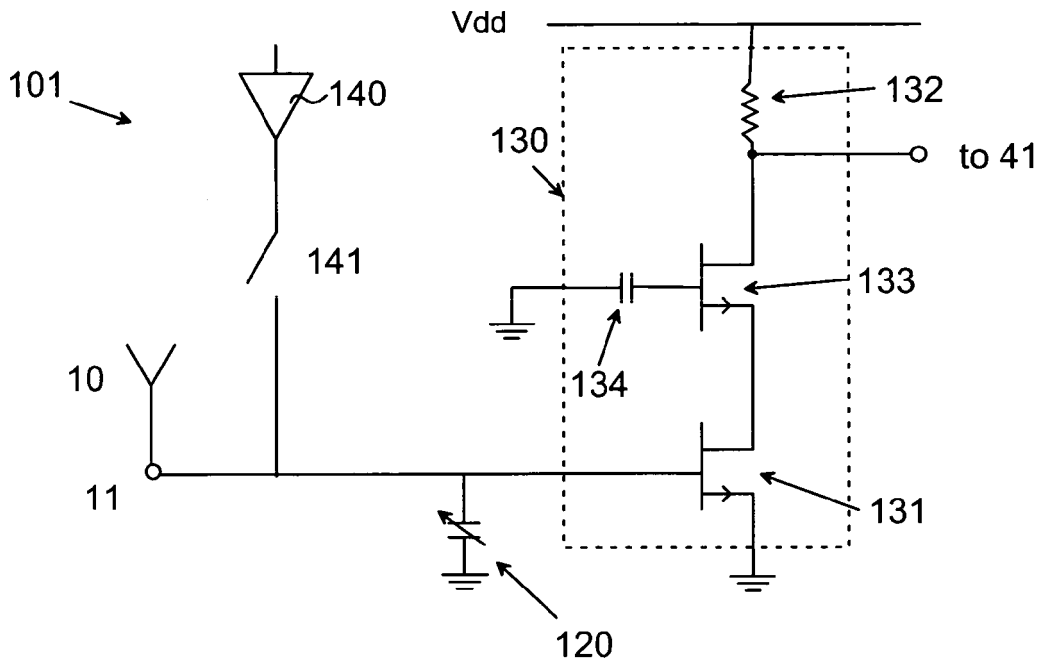

Fig. 3

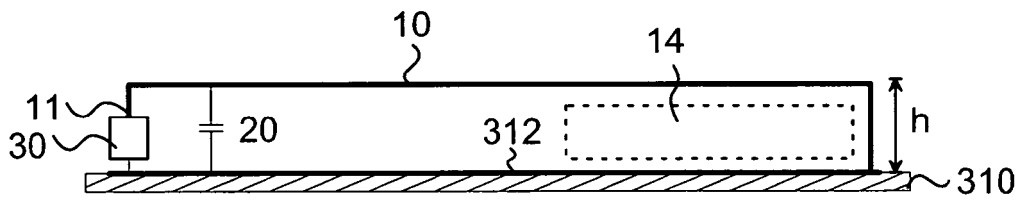

Fig. 4

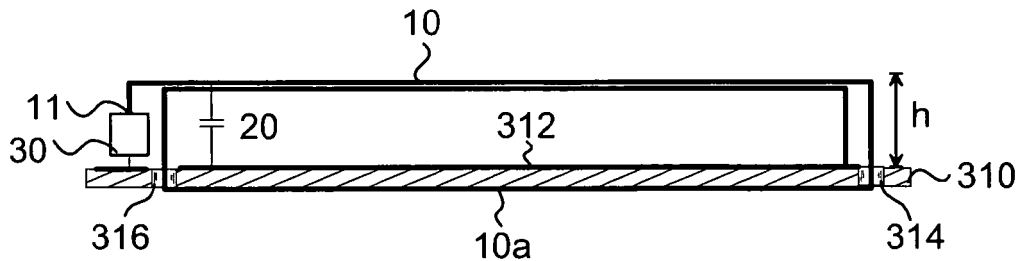

Fig. 5

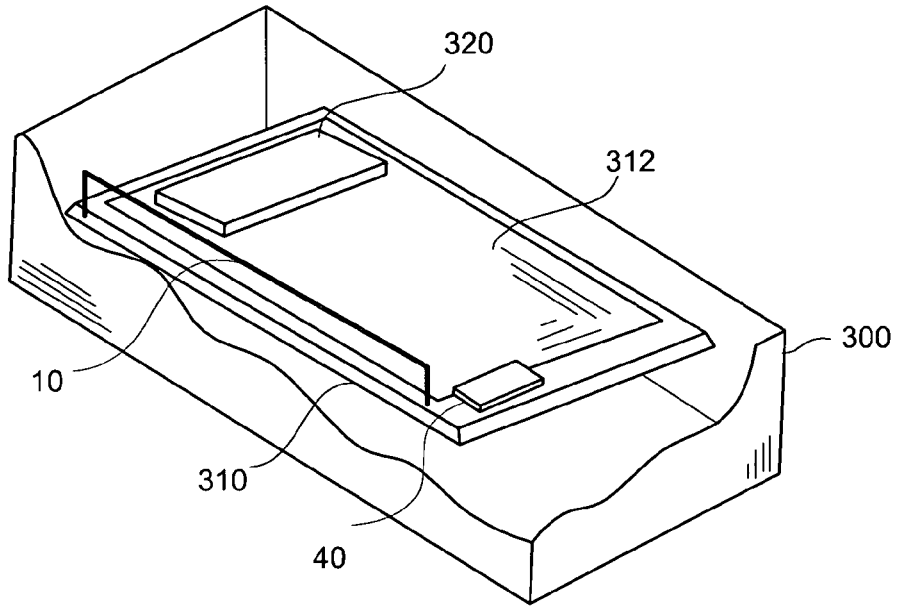

Fig. 6

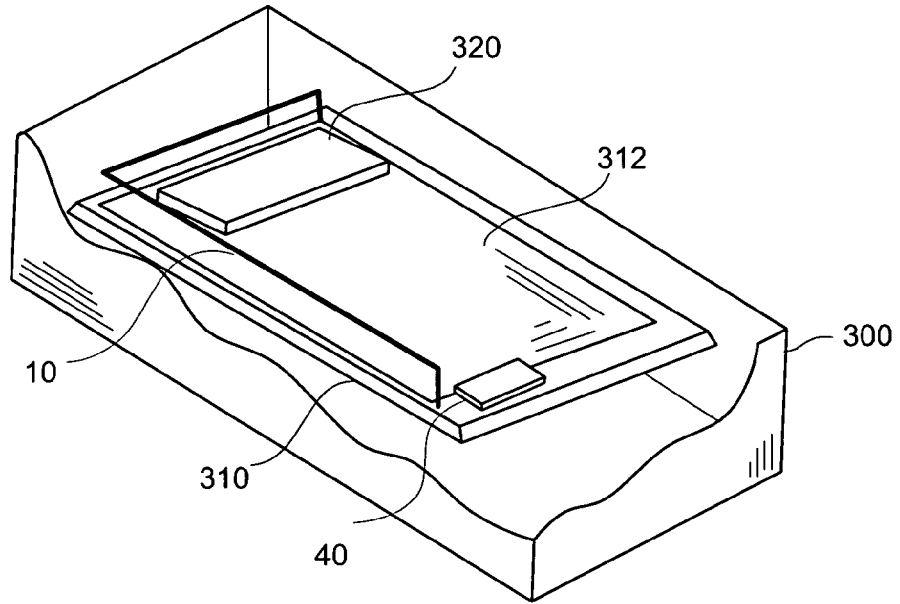

Fig. 7



DOCUMENTS CONSIDERED TO BE RELEVANT			
Category	Citation of document with indication, where appropriate, of relevant passages	Relevant to claim	CLASSIFICATION OF THE APPLICATION (IPC)
X	US 5 767 813 A (VERMA VIKRAM [US] ET AL) 16 June 1998 (1998-06-16) * the whole document * -----	1-13	INV. H01Q7/00 H01Q7/06 H01Q9/42 H01Q21/28 H01Q1/24
X	US 2004/172146 A1 (SCHNEIDER GERHARD [CH] ET AL) 2 September 2004 (2004-09-02) * the whole document * -----	1-13	
X	EP 1 594 188 A1 (MATSUSHITA ELECTRIC IND CO LTD [JP]) 9 November 2005 (2005-11-09) * the whole document * -----	1-13	
X	EP 1 120 855 A (SONY CORP [JP]) 1 August 2001 (2001-08-01) * the whole document * -----	1-13	
A	US 5 561 438 A (NAKAZAWA TOSHIHIKO [JP] ET AL) 1 October 1996 (1996-10-01) * the whole document * -----	1-13	
A	EP 0 933 832 A (MATSUSHITA ELECTRIC IND CO LTD [JP]) 4 August 1999 (1999-08-04) * paragraph [0068]; figures 24-27 * -----	7	
The present search report has been drawn up for all claims			TECHNICAL FIELDS SEARCHED (IPC)
			H01Q
Place of search		Date of completion of the search	Examiner
The Hague		18 May 2007	Fredj, Aziz
CATEGORY OF CITED DOCUMENTS			
X : particularly relevant if taken alone Y : particularly relevant if combined with another document of the same category A : technological background O : non-written disclosure P : intermediate document		T : theory or principle underlying the invention E : earlier patent document, but published on, or after the filing date D : document cited in the application L : document cited for other reasons & : member of the same patent family, corresponding document	

1
EPO FORM 1503 03 82 (P04C01)

ANNEX TO THE EUROPEAN SEARCH REPORT
ON EUROPEAN PATENT APPLICATION NO.

EP 07 44 5011

This annex lists the patent family members relating to the patent documents cited in the above-mentioned European search report. The members are as contained in the European Patent Office EDP file on
The European Patent Office is in no way liable for these particulars which are merely given for the purpose of information.

18-05-2007

Patent document cited in search report	Publication date	Patent family member(s)	Publication date
US 5767813 A	16-06-1998	US 5485166 A WO 9428594 A1	16-01-1996 08-12-1994
US 2004172146 A1	02-09-2004	NONE	
EP 1594188 A1	09-11-2005	WO 2004070879 A1 JP 3735635 B2 KR 20050098880 A US 2006114159 A1	19-08-2004 18-01-2006 12-10-2005 01-06-2006
EP 1120855 A	01-08-2001	CN 1332489 A JP 2001284935 A US 2001040531 A1	23-01-2002 12-10-2001 15-11-2001
US 5561438 A	01-10-1996	NONE	
EP 0933832 A	04-08-1999	CN 1230800 A US 6271796 B1	06-10-1999 07-08-2001

EPO FORM P0469

For more details about this annex : see Official Journal of the European Patent Office, No. 12/82