

## FASCICULE DE BREVET D'INVENTION

21 Numéro de dépôt : 1201200351  
(PCT/GB12/050330)

22 Date de dépôt : 14.02.2012

30 Priorité(s) :  
GB n° GB 1107072.9 du 27/04/2011

24 Délivré le : 31.08.2017

45 Publié le : 16.02.2018

73 Titulaire(s) :

Davy Process Technology Limited,  
10 Eastbourne Terrace,  
LONDON W2 6LG (GB)

72 Inventeur(s) :

GAMLIN, Timothy Douglas (GB)

74 Mandataire : SCP AKKUM, AKKUM &  
ASSOCIATES, 1089, Avenue Douala Manga-Bell,  
Bali, B.P. 4237, DOUALA (CM).

54 Titre : Process for the synthesis of methanol.

57 Abrégé :

A process for the conversion of synthesis gas to methanol by contacting a gaseous stream comprising synthesis gas with a particulate catalyst, said process being carried out in a tubular reactor having an inlet and an outlet, said outlet being located downstream of the inlet, said reactor comprising one or more tubes having located therein one or more carriers for said particulate catalyst and cooling medium in contact with said tubes; wherein said catalyst carrier comprises: an annular container for holding catalyst in use, said container having a perforated inner wall defining a tube, a perforated outer wall, a top surface closing the annular-container and a bottom surface closing the annular container;

a surface closing the bottom of said tube formed by the inner wall of the annular container;

a skirt extending upwardly from the perforated outer wall of the annular container from a position at or near the bottom surface of said container to a position below the location of a seal; and a seal located at or near the top surface and extending from the container by a distance which extends beyond an outer surface of the skirt; said process comprising :

- (a) introducing the gaseous reactants through the inlet;
- (b) passing said reactants downwardly through said at least one tube to the upper surface of the, or the first catalyst carrier where they pass into the passage defined by the inner perforated wall of the container before passing radially through the catalyst bed towards the perforated outer wall;
- (c) allowing reaction to occur as the synthesis gas contacts the catalyst;
- (d) passing unreacted reactant and product out of the container through the perforated outer wall and then

upwardly between the inner surface of the skirt and the outer wall of the annular container until they reach the seal where they are directed over the end of the skirt and caused to flow downwardly between the outer surface of the skirt and the inner surface of the reactor tube where heat transfer takes place; (e) repeating steps (b) to (d) at any subsequent catalyst carrier; and (f) removing product from the outlet.

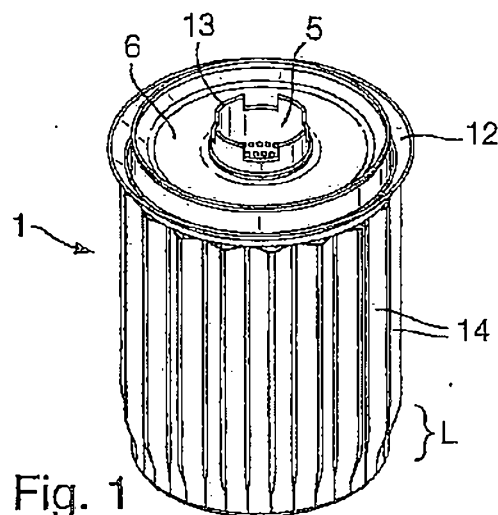

Fig. 1

The present invention relates to a process for the conversion of carbon monoxide, carbon dioxide and hydrogen, collectively known as synthesis gas to liquid products in the presence of a methanol synthesis catalyst. The synthesis gas may be derived from a number of sources such as reformed natural gas or by the gasification of coal or biomass.

5

The field of methanol synthesis has become an area of renewed interest in recent years as the uses of methanol have extended into such areas as fuel additives and for use in the production of olefins. Much of the interest has stemmed from China where "coal to chemicals" and "coal to fuel" plants have been built in areas where large quantities of coal are located. This offers the opportunity to monetarise on this coal where it is located in remote areas, and can be difficult and/or expensive to transport.

10

It is therefore desirable to optimise the methanol production process. Several approaches to this have been made and these have generally been directed at reactor design or at the catalyst formulation. One of the major issues with the process is that the heat evolved, whilst being approximately half that produced in a Fischer-Tropsch reaction for the same quantity of carbon oxide converted, improvements in catalyst activity and/or the use of more reactive coal-derived gases are beginning to challenge the heat transfer capability of current designs.

15

One approach to handling the heat evolved is to carry out the reaction in a fixed bed reactor. An example of a suitable reactor design can be found in GB 1364357. In this arrangement, catalyst pellets are loaded inside tubes of an axial reactor. Cooling medium, such as vaporising water, is supplied around the tubes. Reactant gases are then passed through the tubes where they contact the catalyst and the methanol forming reaction takes place. The heat evolved is transferred through the tube wall to the surrounding cooling medium. However, heat transfer resistance from the centre of the tube to the wall can be significant and therefore, in view of the need to control the heat within the tube, the size of the tubes is limited to allow the heat to pass readily from the centre of the tubes to the walls where heat exchange occurs. Generally therefore the tubes have a diameter of less than about 40 mm to ensure the required

20

25

level of heat transfer and to prevent the catalyst located towards the centre of the tube overheating which will increase the production of by-products. This represents not only a loss in conversion to the desired product but also leads to the need to separate the by-products which increases costs. The small size of the tubes contributes to the high cost of construction of these reactors.

In addition careful selection of conditions such as superficial velocity and gas hourly space velocity has to be made in order to maintain the required heat transfer and to achieve the required conversion at a reasonable overall pressure drop.

These reactors are difficult to load with catalyst since it must be loaded into individual tubes while taking measures to ensure that the tubes are evenly loaded.

An alternative approach is to carry out the reaction in a bubble slurry reactor such as that described in US 4628066. In this arrangement, small catalyst particles, such as those of 150  $\mu\text{m}$  or less, are suspended in the hydrocarbon product and are agitated by the injection of reaction gas at the bottom of the reactor. The gas becomes highly dispersed throughout the reactor and the heat generated by the reaction can be effectively transferred particularly with highly reactive coal gases. There is a limit to how concentrated the slurry can be and thus a significant proportion of the reactor is taken up with heat transfer liquid.

When these reactors are operating, the gas hold ups within the slurry are significant. This requires extra reactor capacity to accommodate the slurry bed in the gassed state. To accommodate this, the reactors are generally large in comparison to those used in gas phase reactions. Although these reactors offer the benefit of simpler catalyst loading they do not appear to have been widely practiced.

An alternative approach is to use a so-called catalyst in shell design reactor such as that described in US 4778662 in which the cooled reactant gas flows axially counter-current to the reacting gas in a series of tubes arranged vertically throughout the catalyst bed. The cool reactant gas fed to the reactor is heated by absorbing the methanol reaction heat produced in the catalyst bed surrounding the tube. By the time the gas emerges from the open tube above the catalyst bed it is at reaction

temperature. It then flows down through the catalyst bed where methanol is evolved. As the reaction is equilibrium limited in many cases the recycle needed to absorb the heat of reaction can be easily arranged. As the axial length of reactors of this type can be limited by pressure drop considerations the diameter of the reactor has to increase  
5 to accommodate the required capacity. If logistical considerations limit the size of the reactor which can be deployed, the capacity of the reactor can also be limited.

The design described in US 4339413 is complicated and expensive to build at larger sizes and has not seen extensive use in the production of methanol.

An alternative approach is to use a radial stream raising reactor of the type first  
10 disclosed in US 4321234. Reactors of this type have various advantages including that they of a simple design, are easy to build, easy to load and unload, have a low pressure drop and a high single reactor capacity. For current catalysts it does offer a very effective design for the broad spectrum of synthesis gases and can achieve very  
15 large capacities in a single reactor of very moderate diameter and weight. However, as a new generation of state of the art catalysts such as that described in WO 2010/0146380 emerge, the ability to remove heat will become more difficult.

An alternative approach is described in CA1251019 in which a four stage adiabatic reaction system with external cooling after the first and second stage is used. This allows efficient use of catalyst. However, it is relatively expensive to arrange.

20 Thus it will be understood that whilst the various approaches to carrying out reactions for the production of methanol each offer some advantages, they also each have their own disadvantages. There is therefore still a need to provide an improved methanol synthesis process which addresses one or more of the problems of prior art arrangements.

25 According to the present invention there is provided a process for the conversion of synthesis gas to methanol by contacting a gaseous stream comprising synthesis gas with a particulate catalyst, said process being carried out in a tubular reactor having an inlet and an outlet, said outlet being located downstream of the inlet, said reactor

comprising one or more tubes having located therein one or more carriers for said particulate catalyst and cooling medium in contact with said at least one tube; wherein said catalyst carrier comprises:

5 an annular container holding catalyst, said container having a perforated inner wall defining a tube, a perforated outer wall, a top surface closing the annular container and a bottom surface closing the annular container;

a surface closing the bottom of said tube formed by the inner wall of the annular container;

10 a skirt extending upwardly from the perforated outer wall of the annular container from a position at or near the bottom surface of said container to a position below the location of a seal; and

a seal located at or near the top surface and extending from the container by a distance which extends beyond an outer surface of the skirt; said process comprising:

(a) introducing the gaseous reactants through the inlet;

15 (b) passing said reactants downwardly through said at least one tube to the upper surface of the, or the first, catalyst carrier where they pass into the passage defined by the inner perforated wall of the container before passing radially through the catalyst bed towards the perforated outer wall;

(c) allowing reaction to occur as the synthesis gas contacts the catalyst;

20 (d) passing unreacted reactant and product out of the container through the perforated outer wall and then upwardly between the inner surface of the skirt and the outer wall of the annular container until they reach the seal where they are directed over the end of the skirt and caused to flow downwardly between the outer surface of the skirt and the inner surface of the reactor tube where heat transfer takes place;

25 (e) repeating steps (b) to (d) at any subsequent catalyst carrier; and

(f) removing product from the outlet.

The catalyst carrier is described in detail in PCT/GB2010/001931 filed on 19<sup>th</sup> October 2010 which is incorporated herein by reference.

25 For the avoidance of doubt, any discussion of orientation, for example terms such as upwardly, below, lower, and the like have, for ease of reference been discussed with regard to the orientation of the catalyst carrier as illustrated in the accompanying

drawings. However, where the tubes, and hence the catalyst carrier, are used in an alternative orientation, the terms should be construed accordingly.

5 The catalyst container will generally be sized such that it is of a smaller dimension than the internal dimension of the reactor tube into which it is placed. The seal is sized such that it interacts with the inner wall of the reactor tube when the catalyst carrier of the present invention is in position within the tube. The seal need not be perfect provided it is sufficiently effective to cause the majority of the flowing gas to pass through the carrier.

10 Generally, a plurality of catalyst carriers will be stacked within the reactor tube. In this arrangement, the reactants/products flow downwardly between the outer surface of the skirt of a first carrier and the inner surface of the reactor tube until they contact the upper surface and seal of a second carrier and are directed downwardly into the tube of the second carrier defined by the perforated inner wall of its annular container. The flow path described above is then repeated.

15 The catalyst carrier may be formed of any suitable material. Such material will generally be selected to withstand the operating conditions of the reactor. Generally, the catalyst carrier will be fabricated from carbon steel, aluminium, stainless steel, other alloys or any material able to withstand the reaction conditions.

20 The wall of the annular container can be of any suitable thickness. Suitable thickness will be of the order of about 0.1 mm to about 1.0 mm, preferably of the order of about 0.3 mm to about 0.5 mm.

25 The size of the perforations in the inner and outer walls of the annular container will be selected such as to allow uniform flow of reactant(s) and product(s) through the catalyst while maintaining the catalyst within the container. It will therefore be understood that their size will depend on the size of the catalyst particles being used. In an alternative arrangement the perforations may be sized such that they are larger but have a filter mesh covering the perforations to ensure catalyst is maintained within the annular container. This enables larger perforations to be used which will facilitate the free movement of reactants without a significant loss of pressure.

It will be understood that the perforations may be of any suitable configuration. Indeed where a wall is described as perforated all that is required is that there is means to allow the reactants and products to pass through the walls. These may be small apertures of any configuration, they may be slots, they may be formed by a wire screen or by any other means of creating a porous or permeable surface.

Although the top surface closing the annular container will generally be located at the upper edge of the or each wall of the annular container, it may be desirable to locate the top surface below the upper edge such that a portion of the upper edge of the outer wall forms a lip. Similarly, the bottom surface may be located at the lower edge of the, or each, wall of the annular container or may be desirable to locate the bottom surface such that it is above the bottom edge of the wall of the annular container such that the wall forms a lip.

The bottom surface of the annulus and the surface closing the bottom of the tube may be formed as a single unit or they may be two separate pieces connected together. The two surfaces may be coplanar but in a preferred arrangement, they are in different planes. In one arrangement, the surface closing the bottom of the tube is in a lower plane than the bottom surface of the annular container. This serves to assist in the location of one carrier on to a carrier arranged below it when a plurality of containers are to be used. It will be understood that in an alternative arrangement, the surface closing the bottom of the tube may be in a higher plane than the bottom surface of the annular container.

Whilst the bottom surface will generally be solid, it may include one or more drain holes. Where one or more drain holes are present, they may be covered by a filter mesh. Similarly a drain hole, optionally covered with a filter mesh may be present in the surface closing the bottom of the tube. Where the carrier is to be used in a non-vertical orientation, the drain hole, where present will be located in an alternative position i.e. one that is the lowest point in the carrier when in use.

One or more spacer means may extend downwardly from the bottom surface of the annular container. The, or each, spacer means may be formed as separate components

or they may be formed by depressions in the bottom surface. Where these spacer means are present they assist in providing a clear path for the reactants and products flowing between the bottom surface of the first carrier and the top surface of a second lower carrier in use. The spacer may be of the order of about 4 mm to about 15 mm, or about 6 mm deep. Alternatively, or additionally, spacer means may be present on the top surface.

The top surface closing the annular container may include on its upper surface means to locate the container against a catalyst carrier stacked above the container in use. The means to locate the container may be of any suitable arrangement. In one arrangement it comprises an upstanding collar having apertures or spaces therein to allow for the ingress of reactants.

The upwardly extending skirt may be smooth or it may be shaped. Any suitable shape may be used. Suitable shapes include pleats, corrugations, and the like. The pleats, corrugations and the like will generally be arranged longitudinally along the length of the carrier. The shaping of the upstanding skirt increases the surface area of the skirt and assists with the insertion of the catalyst carrier into the reaction tube since it will allow any surface roughness on the inner surface of the reactor tube or differences in tolerances in tubes to be accommodated.

Where the upwardly extending skirt is shaped, it will generally be flattened to a smooth configuration towards the point at which it is connected to the annular container to allow a gas seal to be formed with the annular container. The upstanding skirt will generally be connected to the outer wall of the annular container at or near the base thereof. Where the skirt is connected at a point above the bottom of the wall, the wall will be free of perforations in the area below the point of connection. The upstanding skirt may be flexible.

Generally, the upstanding skirt will stop at about 0.5 cm to about 1.5 cm, preferably about 1 cm, short of the top surface of the annular container.

Without wishing to be bound by any theory, it is believed that the upstanding skirt serves to gather the reactants/products from the perforated outer wall of the annular

container and direct them via the shapes towards the top of the catalyst carrier collecting more reactants/products exiting from the outer wall of the annular container as they move upwardly. As described above, reactants/products are then directed down between the tube wall and the outside of the upstanding skirt. By this method the heat transfer is enhanced down the whole length of the carrier but as the heat exchange is separated from the catalyst, hotter or colder as appropriate heat exchange fluid can be used without quenching the reaction at the tube wall and at the same time ensuring that the temperature of the catalyst towards the centre of the carrier is appropriately maintained.

The seal may be formed in any suitable manner. However, it will generally be sufficiently compressible to accommodate the smallest diameter of the reactor tube. The seal will generally be a flexible, sliding seal. In one arrangement, an O-ring may be used. A compressible split ring or a ring having a high coefficient of expansion could be used. The seal may be formed of any suitable material provided that it can withstand the reaction conditions. In one arrangement, it may be a deformable flange extending from the carrier. The flange may be sized to be larger than the internal diameter of the tube such that as the container is inserted into the tube it is deformed to fit inside and interact with the tube.

In the present invention, the annular space between the outer surface of the catalyst container and the inner surface of the tube wall is small, generally of the order of from about 3 mm to about 15 mm or about 10 mm. This narrow gap allows a heat transfer coefficient to be achieved such that an acceptable temperature difference of the order of about 10 °C to about 40 °C between the cooled exit gas and the coolant to be achieved.

The size of the annulus between the skirt and the catalyst wall and the skirt and the tube wall will generally be selected to accommodate the gas flow rate required while maintaining high heat transfer and low pressure drop. Thus the process of the present invention may additionally include the step of selecting the appropriate size of the annulus to meet these criteria.

The process of the present invention enables relatively large reactor tubes to be used. In particular, tubes having diameters in the region of from about 75 mm to about 130 mm or even about 150 mm can be used compared to diameters of less than about 40 mm used in conventional systems. The larger diameter tubes will allow capacity in the region of about 5000 tonnes per day of methanol in a single reactor of approximately 5 m and 500 tonnes in weight

As discussed above the exothermic nature of the methanol synthesis reaction is a major factor in the design of a reactor in which the reaction can be carried out. The use of the catalyst carrier in the process of the present invention, allows the tubes in an axial steam raising reactor comprising a plurality of catalyst carriers to become, in effect, a plurality of adiabatic reactors with inter-cooling.

Any suitable catalyst may be used in the process of the present invention. Powdered, foamed, structured, or other suitable forms may be used.

One benefit of the process of the present invention is that the carrier allows for the deployment of different diameter catalysts to be used such as those having diameters of from about 100  $\mu\text{m}$  to about 1 mm. Since these are used in a fixed bed, the mass transfer resistances can be greatly reduced over prior art arrangements in which a fixed bed is not used. This will lead to improved selectivity to the required products.

Further, as catalysts with diameters at the low end of the range have a high surface area and are located in the direct flow of the reacting gas, they are maintained at a temperature which is very similar to that of the flowing gas. This will reduce the tendency to by-product formation.

In one alternative arrangement, a monolith catalyst may be used. In this arrangement, the structure of the catalyst container may be modified. Full details of a catalyst container suitable for use with a monolith catalyst is described in GB patent application no 1105691.8 filed 4<sup>th</sup> April 2011 the contents of which are incorporated herein by reference.

Thus according to a second aspect of the present invention there is provided a process for the conversion of synthesis gas to methanol by contacting a gaseous stream comprising synthesis gas with a monolith catalyst, said process being carried out in a tubular reactor having an inlet and an outlet, said outlet being located downstream of the inlet, said reactor comprising one or more tubes having located therein one or more carriers for said monolith catalyst and cooling medium in contact with said tubes;

wherein said catalyst carrier comprises:

a container holding a monolith catalyst, said container having a bottom surface closing the container and a skirt extending upwardly from the bottom surface of said container to a position below the location of a seal and spaced therefrom, said skirt being positioned such that there is a space between an outer surface of the monolith catalyst and the skirt; and

a seal located at or near a top surface of the monolith catalyst and extending from the monolith catalyst by a distance which extends beyond an outer surface of the skirt; said process comprising:

- (a) introducing the gaseous reactants through the inlet;
- (b) passing said reactants downwardly through said at least one tube to the upper surface of the, or the first, monolith catalyst where they pass through the monolith catalyst;
- (c) allowing reaction to occur as the synthesis gas contacts the catalyst;
- (d) passing unreacted reactant and product out of the catalyst and then upwardly between the inner surface of the skirt and the outer surface of the monolith catalyst until they reach the seal where they are directed over the end of the skirt and caused to flow downwardly between the outer surface of the skirt and the inner surface of the reactor tube where heat transfer takes place;
- (e) repeating steps (b) to (d) at any subsequent catalyst carrier; and
- (f) removing product from the outlet.

In one arrangement, the monolith catalyst is a solid, in that there is substantially no space within the body of the monolith that is not occupied by catalyst. When the monolith is in use in a vertical reactor with downflow, the reactant(s) flow downwardly through the reactor tube, the reactant(s) first contacts the upper face of

the monolith catalyst and flows therethrough in a direction parallel to the axis of the cylinder. The seal of the container prevents the reactant(s) from flowing around the monolith and assists the direction of the reactants into the catalyst. Reaction will then occur within the monolith catalyst. The product will then also flow down through the monolith in a direction parallel to the axis of the cylinder.

5

Once the reactant(s) and product reach the bottom surface of the catalyst carrier they are directed towards the skirt of the carrier. To facilitate this flow, feet may be provided within the carrier on the upper face of the bottom surface such that, in use, the catalyst monolith is supported on the feet and there is a gap between the bottom of the catalyst monolith and the bottom surface of the catalyst carrier. The upwardly extending skirt then directs the reactant(s) and product upwardly between the inner surface of the skirt and the outer surface of the monolith catalyst until they reach the underside of the seal. They are then directed, by the underside of the seal, over the end of the skirt and they then flow downwardly between the outer surface of the skirt and the inner surface of the reactor tube where heat transfer takes place.

10

15

In one alternative arrangement, the monolith catalyst has a channel extending longitudinally therethrough. Generally the channel will be located on the central axis of the monolith catalyst. Thus where the reactor tube is of circular cross-section, the monolith catalyst of this arrangement will be of annular cross-section. In this arrangement, in use, in a vertical reactor with downflow, reactant(s) flow downwardly through the reactor tube and thus first contacts the upper surface of the monolith catalyst. The seal blocks the passage of the reactant(s) around the side of the catalyst. Since the path of flow of reactant(s) is impeded by the catalyst, it will generally take the easier path and enter the channel in the monolith. The reactant(s) then enters the annular monolith catalyst and passes radially through the catalyst towards the outer surface of the catalyst monolith. During the passage through the catalyst monolith reaction occurs. Unreacted reactant and product then flow out of the monolith catalyst through the outer surface thereof. The upwardly extending skirt then directs reactant and product upwardly between the inner surface of the skirt and the outer wall of the monolith catalyst until they reach the seal. They are then directed, by the underside of the seal, over the end of the skirt and flow downwardly between the

20

25

30

outer surface of the skirt and the inner surface of the reactor tube where heat transfer takes place.

5 In the arrangement in which the monolith catalyst includes the channel, the catalyst carrier may include a top surface which will extend over the monolith catalyst but leave the channel uncovered. This top surface serves to ensure that the reactant(s) do not enter the catalyst monolith from the top but are directed into the channel for radial flow.

10 The discussion of the specific features of the catalyst carrier above in relation to the first embodiment applies equally in connection to the catalyst carrier for a monolith catalyst of the second embodiment insofar as the relevant features are present.

Whichever type of carrier is used, the number of carriers present per tube will vary with catalyst activity but for tube lengths currently commercially available up to about 200 carriers may be accommodated per tube. This will enable a reasonable temperature rise in the order of from about 10 °C to about 20 °C.

15 The radial flow through the, or each, catalyst carrier within the tube means that the gas flow path length is also very low, of the order of 1 m in total, when compared with prior art arrangements. Total catalyst depths of the order of about 2 metres may even be achieved with a tube of up to 20 metres in length of catalyst hourly space velocities of about 4000. The low flow path means that the overall pressure drop  
20 achieved is an order of magnitude lower than that which would be experienced with the same catalyst in an axial tube not using the process of the present invention.

25 One advantage of being able to achieve a low overall pressure drop by the process of the present invention is that long tubes with high superficial gas velocities, gases containing high quantities of inerts or a gas recycle may easily be accommodated without the pressure drop and potential catalyst crushing disadvantages experienced with high flow through current fixed bed systems. The ability to accommodate recycle will enable overall conversion at lower per pass conversions to be achieved at high catalyst productivity and selectivity.

The catalyst may be repeatedly and reliably reduced and loaded into the carrier at a manufacturing facility. The containers may be assembled in connected units which will simplify the loading of the reactor and in particular will mean that the operators do not have to come into contact with the catalyst. The unloading procedure is also  
5 simplified since the carriers may be readily discharged before being taken for reprocessing.

In one arrangement of the present invention, a plurality of reactors may be used in parallel.

Liquid product stream separated from the stream exiting the reactor will be recovered. In the process of the present invention, unreacted gas exiting the outlet of the each or  
10 each reactor is further treated to remove heat. The removed heat may be reused and/or rejected to cooling. Liquid product separated from the cooled stream exiting the reactor will be recovered. Unreacted gases may be recycled.

In one arrangement, two or more reactors may be located in series fluid communication with facilities located between each reactor to remove heat. The heat  
15 may be reused and/or rejected to cooling. In one arrangement, hydrogen, carbon monoxide and carbon dioxide containing stream exiting the last stage of a series of interconnected reactors may be recycled to any suitable point in the process. In one arrangement it will be recycled to the inlet of the first reactor.

In one alternative arrangement, two or more groups of parallel reactors may be  
20 located in series. In this arrangement, groups of parallel reactors are in series communication with facilities located between each group to remove heat. The heat may be reused and/or rejected to cooling. In one arrangement, liquid product may be removed between each stage with hydrogen and carbon monoxide containing stream being passed to a subsequent reactor group in the series. At least some of the  
25 hydrogen, carbon dioxide and carbon monoxide containing stream exiting the last stage of a series of interconnected reactors may be recycled to any suitable point in the process. In one arrangement it will be recycled to the inlet of the first reactor.

Where the process includes a plurality of reaction stages, a fresh synthesis gas stream may be fed to the second and/or one or more of any subsequent stages.

In one arrangement, the reaction comprises a series of reactor stages each formed of a single reactor or a plurality of reactors in parallel. The series may be constructed such that at least some of the unreacted gas exiting a reactor stage is passed to a subsequent stage. The gas may be cooled before being passed to the next stage.

Any suitable reaction conditions may be used. In one arrangement, the reaction temperature will be from about 150°C to about 330 °C. The reaction pressure may be from about 20 bara to about 130 bara.

The present invention will now be described, by way of example, by reference to the accompanying drawings in which:

Figure 1 is a perspective view from above of the catalyst carrier of the present invention;

Figure 2 is a perspective view of the catalyst carrier from below;

Figure 3 is a partial cross section viewed from the side;

Figure 4 is a simplified diagram of the catalyst carrier of the present invention;

Figure 5 is a schematic illustration of a carrier of the present invention from below when located within a tube;

Figure 6 is a schematic cross section of three catalyst carriers located within a tube;

Figure 7 is an enlarged cross-section of Section A of Figure 6;

Figure 8 is a schematic representation of an alternative embodiment of the present invention, illustrating the flow path;

5 Figure 9 is a schematic representation of a third embodiment of the present invention, illustrating the flow path; and

Figure 10 is a schematic representation of the flow path between two stacked carriers of the kind illustrated in Figure 9.

10 A catalyst carrier 1 of the present invention is illustrated in Figures 1 to 3. The carrier comprises an annular container 2 which has perforated walls 3, 4. The inner perforated wall 3 defines a tube 5. A top surface 6 is closes the annular container at the top. It is located at a point towards the top of the walls 3, 4 of the annular container 2 such that a lip 6 is formed. A bottom surface 7 closes the bottom of the annular container 2 and a surface 8 closes the bottom of tube 5. The surface 8 is located in a lower plane that that of the bottom surface 7. Spacer means in the form of a plurality of depressions 9 are located present on the bottom surface 7 of the annular container 2. Drain holes 10, 11 are located on the bottom surface 7 and the surface 8.

15 A seal 12 extends from the upper surface 6 and an upstanding collar 13 is provided coaxial with the tube 5.

20 A corrugated upstanding skirt 14 surrounds the container 2. The corrugations are flattened in the region L towards the base of the carrier 1.

A catalyst carrier 1 of the present invention located in a reactor tube 15. The flow of gas is illustrated schematically in Figure 4 by the arrows.

25 When a plurality of catalyst carriers of the present invention are located within a reactor tube 15 they interlock as illustrated in Figures 6 and 7. The effect on the flow path is illustrated in the enlarged section shown in Figure 7.

A catalyst carrier 101 of a second embodiment is illustrated in Figure 8. A bottom surface 102 closes the bottom of the container 101. Feet 103 extend upwardly from the bottom surface to support a monolith catalyst 104. An upstanding skirt 105 extends from the bottom surface 102. The skirt may be corrugated and may be flattened as in a region towards the bottom surface 103.

A seal 106 is provided to extend from the monolith catalyst 104 and interact with the wall of the reactor tube 107. Baffles 108 extend upwardly for the seal. These serve to direct flow and to separate the carrier from the bottom surface of a carrier located above the carrier. The flow of gas is illustrated schematically by the arrows.

An alternative embodiment of the present invention is illustrated in Figure 9. In this arrangement the monolith catalyst 104 has a longitudinal channel 109 therethrough. In this arrangement, the feet of the first embodiment may be omitted. This carrier is similar in arrangement to the first embodiment. However, additionally a top surface 110 is provided to cover the upper surface of the monolith catalyst. The flow of gas in the arrangement of Figure 9 is illustrated schematically by the arrows.

When a plurality of catalyst carriers of the present invention are located within a reactor tube 107 the effect on the flow path is illustrated in the enlarged section shown in Figure 10.

It will be understood that whilst the catalyst carriers have been described with particular reference to a use in a tube of circular cross-section the tube may be of non-circular cross-section for example, it may be a plate reactor. Where the tube is of non-circular cross-section, the carrier will be of the appropriate shape. In this arrangement, in the embodiment described in which an annular monolith is used it will be understood that the monolith will not be a circular ring and this term should be construed accordingly.

The present invention may be used in any process for the production of methanol.

**Claims**

1. A process for the conversion of synthesis gas to methanol by contacting a gaseous stream comprising synthesis gas with a particulate catalyst, said process being carried out in a tubular reactor having an inlet and an outlet, said outlet being located downstream of the inlet, said reactor comprising one or more tubes having  
5 located therein one or more carriers for said particulate catalyst and cooling medium in contact with said tubes;

wherein said catalyst carrier comprises:

an annular container for holding catalyst in use, said container having a perforated inner wall defining a tube, a perforated outer wall, a top surface closing the  
10 annular container and a bottom surface closing the annular container;

a surface closing the bottom of said tube formed by the inner wall of the annular container;

a skirt extending upwardly from the perforated outer wall of the annular container from a position at or near the bottom surface of said container to a position  
15 below the location of a seal; and

a seal located at or near the top surface and extending from the container by a distance which extends beyond an outer surface of the skirt; said process comprising:

(a) introducing the gaseous reactants through the inlet;

(b) passing said reactants downwardly through said at least one tube to the  
20 upper surface of the, or the first catalyst carrier where they pass into the passage defined by the inner perforated wall of the container before passing radially through the catalyst bed towards the perforated outer wall;

(c) allowing reaction to occur as the synthesis gas contacts the catalyst;

(d) passing unreacted reactant and product out of the container through the  
25 perforated outer wall and then upwardly between the inner surface of the skirt and the outer wall of the annular container until they reach the seal where they are directed over the end of the skirt and caused to flow downwardly between the outer surface of the skirt and the inner surface of the reactor tube where heat transfer takes place;

(e) repeating steps (b) to (d) at any subsequent catalyst carrier; and

(f) removing product from the outlet.

2. A process according to Claim 1 wherein the catalyst having a diameter of from about 100  $\mu\text{m}$  to about 6 mm

3. A process for the conversion of synthesis gas to methanol by contacting a gaseous stream comprising synthesis gas with a monolith catalyst, said process being carried out in a tubular reactor having an inlet and an outlet, said outlet being located downstream of the inlet, said reactor comprising one or more tubes having located therein one or more carriers for said monolith catalyst and cooling medium in contact with said tubes;

wherein said catalyst carrier comprises:

a container holding a monolith catalyst, said container having a bottom surface closing the container and a skirt extending upwardly from the bottom surface of said container to a position below the location of a seal and spaced therefrom, said skirt being positioned such that there is a space between an outer surface of the monolith catalyst and the skirt; and

a seal located at or near a top surface of the monolith catalyst and extending from the monolith catalyst by a distance which extends beyond an outer surface of the skirt; said process comprising:

(a) introducing the gaseous reactants through the inlet;

(b) passing said reactants downwardly through said at least one tube to the upper surface of the, or the first, monolith catalyst where they pass through the monolith catalyst;

(c) allowing reaction to occur as the synthesis gas contacts the catalyst;

(d) passing unreacted reactant and product out of the catalyst and then upwardly between the inner surface of the skirt and the outer surface of the monolith catalyst until they reach the seal where they are directed over the end of the skirt and caused to flow downwardly between the outer surface of the skirt and the inner surface of the reactor tube where heat transfer takes place;

(e) repeating steps (b) to (d) at any subsequent catalyst carrier; and

(f) removing product from the outlet.

4. A process according to any one of Claims 1 to 3 wherein a plurality of catalyst carriers are stacked within the reactor tube.

5. A process according to any one of Claims 1 to 4 wherein the annular space between the outer surface of the catalyst container and the inner surface of the tube wall is selected to accommodate the gas flow rate required while maintaining high heat transfer and low pressure drop.

6. A process according to any one of Claims 1 to 5 wherein the annular space between the outer surface of the catalyst container and the inner surface of the tube wall is of the order of from about 3 mm to about 15 mm.

7. A process according to any one of Claims 1 to 6 wherein the tubes have a diameter in the region of from about 75 mm to about 200 mm.

8. A process according to any one of Claims 1 to 7 wherein about 200 or more carriers are located within a single tube.

9. A process according to any one of Claims 1 to 8 wherein a plurality of reactors are used in parallel.

10. A process according to any one of Claims 1 to 9 wherein unreacted gas exiting the outlet of the each or each reactor is treated to remove heat.

11. A process according to Claim 10 wherein the removed unreacted gas is reused.

12. A process according to any one of Claims 1 to 8 wherein two or more reactors are located in series.

13. A process according to Claim 12 wherein the reactors located in series are in fluid communication with facilities located between each reactor to remove heat.

14. A process according to Claims 12 or 13 wherein hydrogen and carbon oxides containing stream exiting the last stage of the series of interconnected reactors is recycled to any suitable point in the process.

15. A process according to Claim 14 wherein hydrogen and carbon oxides containing stream exiting the last stage of the series of interconnected reactors is recycled to the first reactor.

5 16. A process according to Claim 9 wherein groups of parallel reactors are in series communication with facilities located between each group to remove heat.

17. A process according to Claim 12 or 16 wherein the heat is reused and/or rejected to cooling.

10 18. A process according to Claim 16, wherein liquid product is removed between each group of parallel reactors with hydrogen and carbon monoxide containing stream being passed to a subsequent reaction group in the series.

19. A process according to Claim 18 wherein hydrogen and carbon monoxide containing stream exiting the last stage of a series of interconnected reactors is recycled to any suitable point in the process.

15 20. A process according to Claim 19 wherein the stream is recycled to the inlet of the first reactor.

21. A process according to any one of Claims 9 to 20 wherein a hydrogen rich stream may be fed to the second and/or one or more of any subsequent reactors or subsequent reactors.

20 22. A process according to any one of Claims 1 to 21 wherein the reaction temperature is from about 150°C to about 330 °C.

23. A process according to any one of Claims 1 to 22 wherein the reaction pressure is from about 20 bara to about 130 bara.

Fig. 1

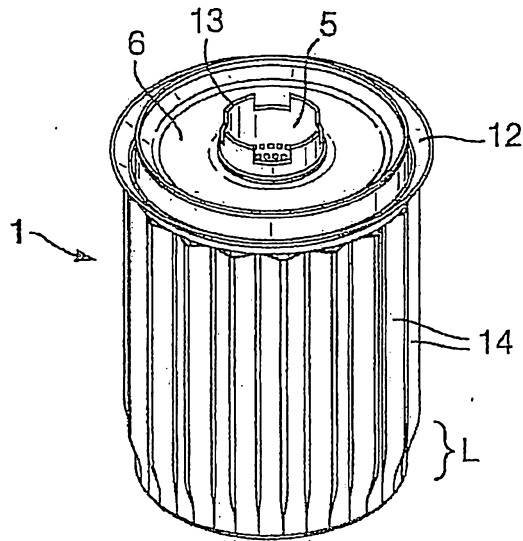

Fig. 2

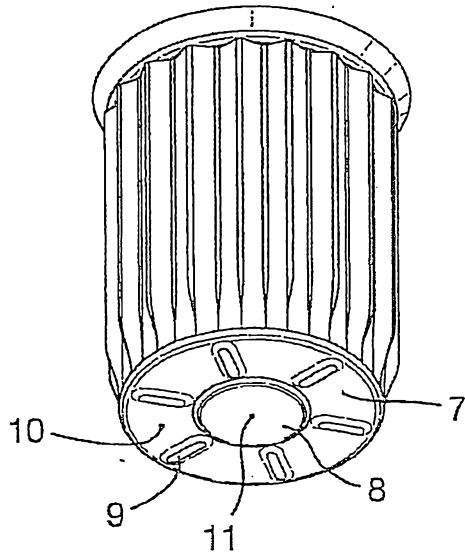

Fig. 3

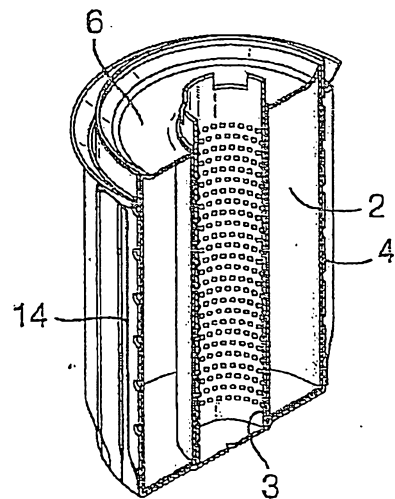

Fig. 4

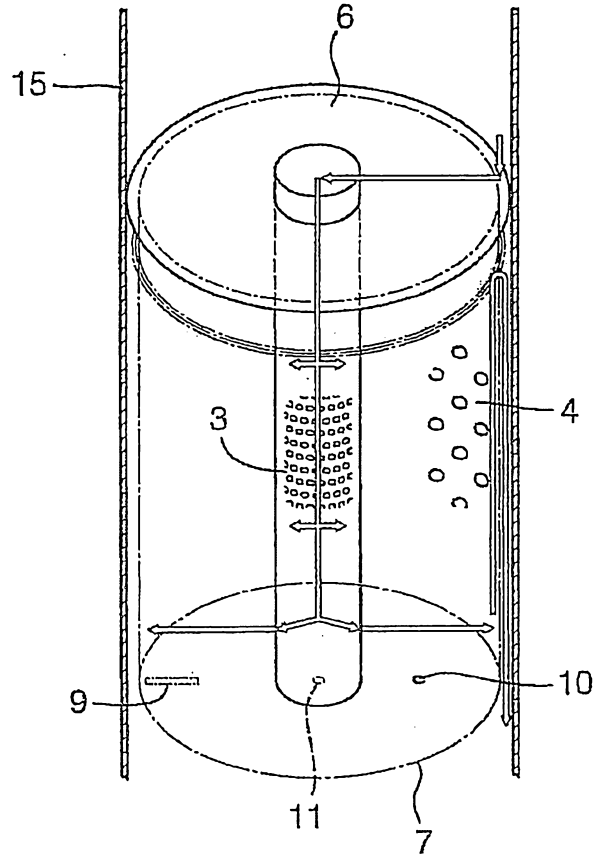

Fig. 5

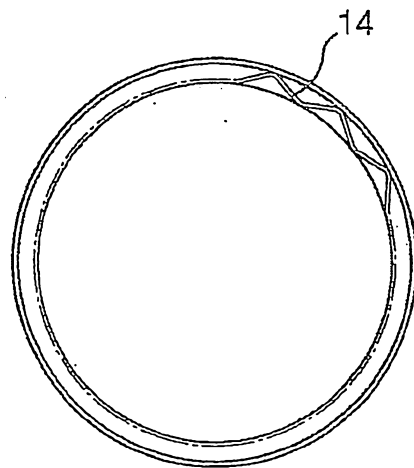

Fig. 6

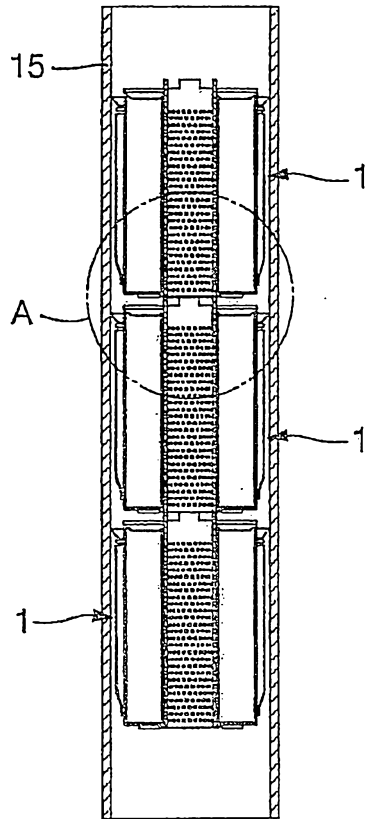
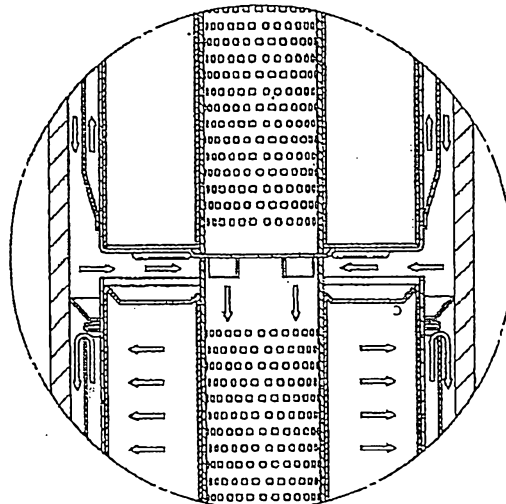

Fig. 7



Detail A

4/5

Fig. 8

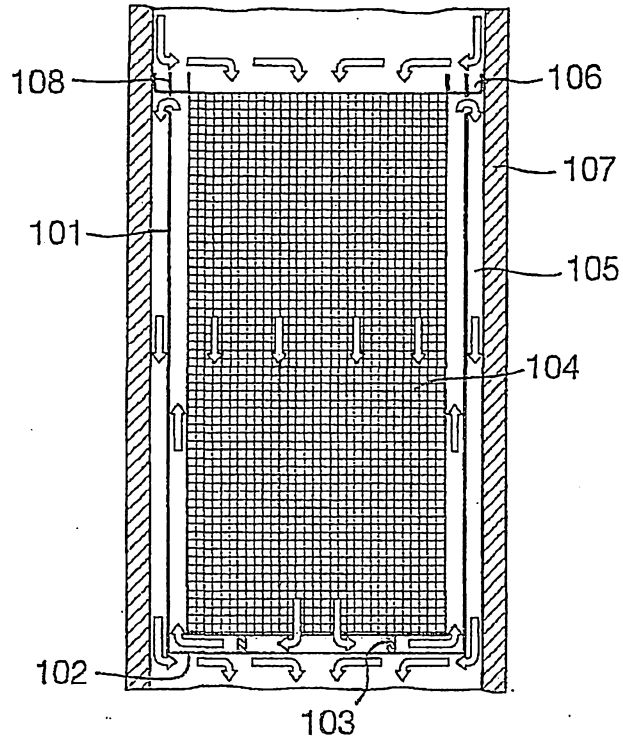

Fig. 9

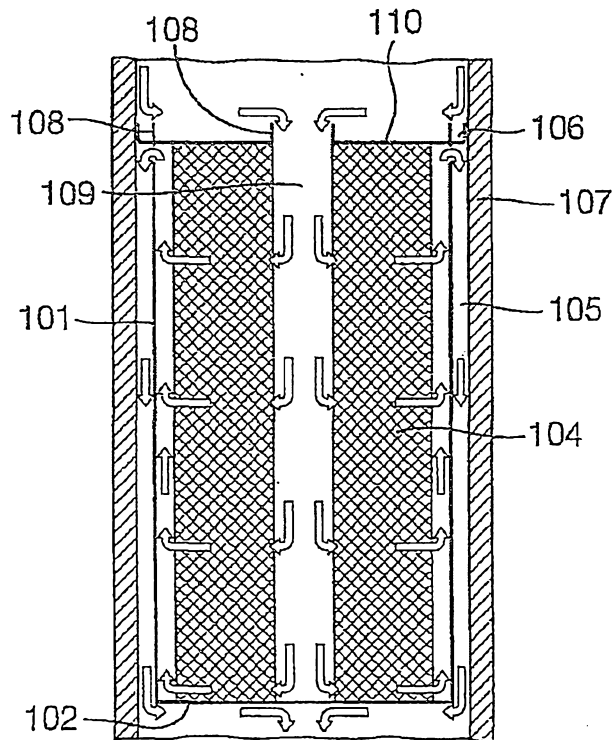
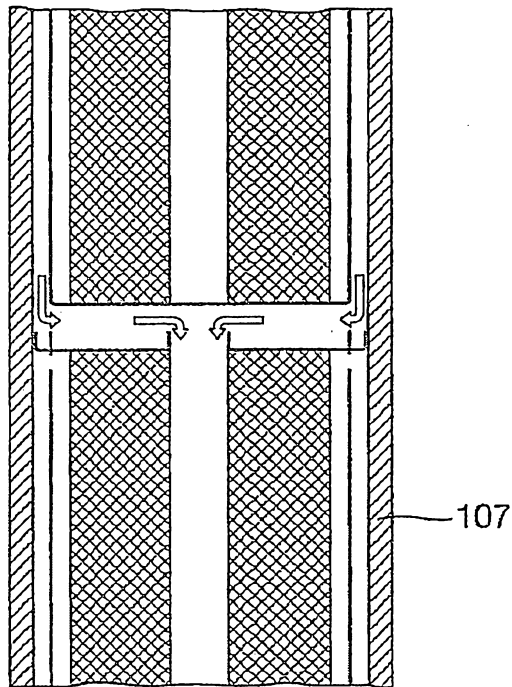

Fig. 10



Abstract

A process for the conversion of synthesis gas to methanol by contacting a gaseous stream comprising synthesis gas with a particulate catalyst, said process being carried out in a tubular reactor having an inlet and an outlet, said outlet being located downstream of the inlet, said reactor comprising one or more tubes having  
5 located therein one or more carriers for said particulate catalyst and cooling medium in contact with said tubes;

wherein said catalyst carrier comprises:

an annular container for holding catalyst in use, said container having a perforated inner wall defining a tube, a perforated outer wall, a top surface closing the annular  
10 container and a bottom surface closing the annular container;

a surface closing the bottom of said tube formed by the inner wall of the annular container;

a skirt extending upwardly from the perforated outer wall of the annular container from a position at or near the bottom surface of said container to a position below the location of a seal; and

a seal located at or near the top surface and extending from the container by a distance  
15 which extends beyond an outer surface of the skirt; said process comprising:

(a) introducing the gaseous reactants through the inlet;  
(b) passing said reactants downwardly through said at least one tube to the upper surface of the, or the first catalyst carrier where they pass into the passage defined by the inner perforated wall of the container before passing radially through the catalyst  
20 bed towards the perforated outer wall;

(c) allowing reaction to occur as the synthesis gas contacts the catalyst;

(d) passing unreacted reactant and product out of the container through the perforated outer wall and then upwardly between the inner surface of the skirt and the outer wall of the annular container until they reach the seal where they are directed over the end of the skirt and caused to flow downwardly between the outer surface of  
25 the skirt and the inner surface of the reactor tube where heat transfer takes place;

(e) repeating steps (b) to (d) at any subsequent catalyst carrier; and

(f) removing product from the outlet.