

- [54] CIGARETTE GAS LIGHTER
- [76] Inventor: **Jean Gaston Tricot**, 53, Rue du Val d'Osne 94, Saint-Maurice, France
- [22] Filed: **Feb. 11, 1971**
- [21] Appl. No.: **114,572**
- [30] Foreign Application Priority Data
Feb. 12, 1970 France.....7005085
- [52] U.S. Cl.222/3, 222/545, 431/344
- [51] Int. Cl.F23d 3/00
- [58] Field of Search.....222/3, 520, 545;
431/344

- [56] **References Cited**
- UNITED STATES PATENTS
- 3,014,357 12/1961 Zellweger222/545 X
- 3,118,295 1/1964 Van Poppel.....222/3
- Primary Examiner*—Robert B. Reeves
- Assistant Examiner*—Thomas E. Kocovsky
- Attorney*—Waters, Roditi, Schwartz & Nissen

[57] **ABSTRACT**
Cigarette gas lighter body with a tapped well for engagement with a screw-threaded valve body. The lighter body has, above and around the tapped well, a neck formed by an outer extension with a cylindrical bore and, at the base thereof, an inner groove imparting radial elasticity to the neck.

1 Claim, 3 Drawing Figures

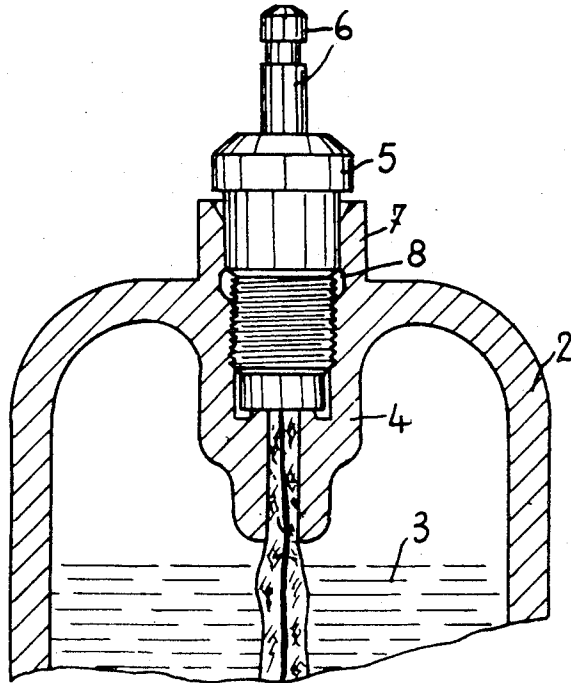

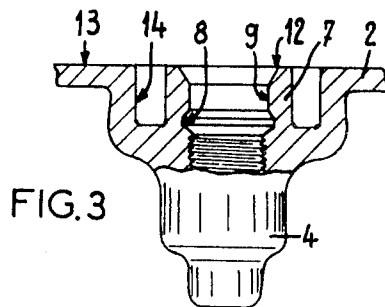
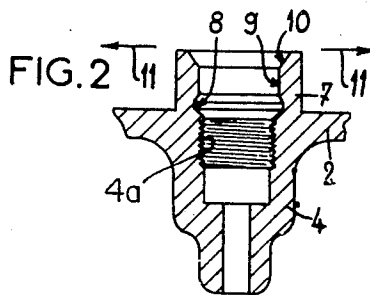
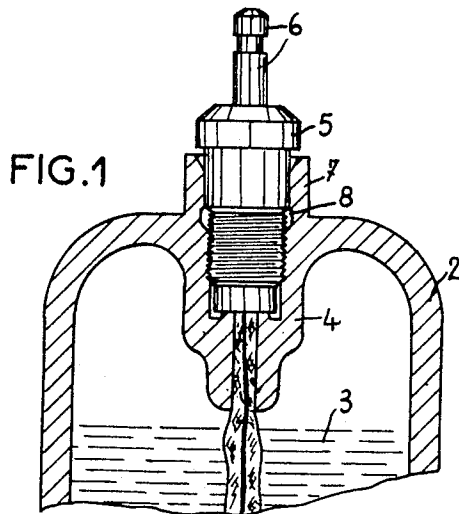

CIGARETTE GAS LIGHTER**FIELD OF THE INVENTION**

The present invention relates to improvements in the bodies of cigarette gas lighters of the type wherein the plastic body constituting the reservoir for the liquefied gas fuel comprises a tapped well adapted to receive a screw-threaded valve body or unit incorporating the valve member controlling the opening and closing of the valve seat for delivering the gaseous fuel by pressure-release action.

DESCRIPTION OF PRIOR ART

In cigarette —or cigar— lighters of this character the gas flowing from the reservoir penetrates into the valve body and, if the valve member is unseated, flows through this body to the burner. Considering the necessary functional clearance to be provided between the threaded portion of the valve body and the tapped hole of the well formed in the lighter body, adequate means must be provided for properly sealing the joint between the wall of said well and the valve body and thus avoid any detrimental gas leakage.

As a rule, these means consist of O-rings disposed in a groove provided to this end in the valve body and registering with the upper portion of said well. Although the fluid-tightness thus obtained is amply satisfactory, the use of this conventional technique involves the machining of a groove and the fitting of the O-ring therein which constitutes a costly operation increasing the cost of the lighter itself especially in the case of cheap or "lost" lighter, i.e., of the type usually thrown away when the fuel is exhausted.

To avoid this inconvenience various attempts have been made notably by providing an injection-moulded plastic valve body formed with an integral circular lip or flange ensuring the necessary fluid-tightness associated with the cylindrical inner wall of the well, the outer edge of the lip or flange bearing resiliently there-against.

However, actual practice proved that this solution was not completely satisfactory for to obtain a reliable fluid-tightness the lip, at least in the vicinity of its free edge must have a diameter slightly greater than the inner diameter of said well ; under these conditions, it is clear that during the assembling operation this lip undergoes a slight reduction in diameter which, due to its resiliency, cannot compress the lip material but imparts to this lip a somewhat corrugated shape which, approximately, may be compared to that of a bottle crown cap. As a result, the outer periphery of the lip is formed with radial splines which, although very small, facilitate gas leakages. Moreover, in case of temperature increment, notably when the cigarette lighter is operated during relatively longtime periods, the plastic valve body expands more than the well material so as to further increase the lip distortion and therefore the gas leakages resulting therefrom.

SUMMARY OF THE INVENTION

The improvements according to the present invention are intended to provide sealing means which, without unduly incrementing the cigarette-lighter assembling time, preserves its efficiency irrespective of the temperatures likely to be encountered under normal or prolonged service conditions.

According to this invention, the well formed in the lighter body or reservoir for receiving the valve body comprises a neck-forming cylindrical outer extension of plastic material injection-moulded integrally with the lighter body or reservoir, said outer extension comprising at its base an inner groove imparting a certain radial elasticity thereto and, on the remaining upper portion of the neck, a smooth cylindrical bore of a diameter slightly smaller than the groove diameter and also than the outer diameter of the valve body, so that this inner wall resiliently engages said valve body and provides by itself the necessary gas tightness.

The importance of this cylindrical resilient neck is considerable because on the one hand when the valve body is introduced into the well said neck is caused to expand or flare out, therefore without forming splines or other distortions facilitating the escape of gas, and on the other hand it permits immediately, upon completion of the assembling operation and due to its radial resiliency, of removing the spindle or like tool necessary for forming the inner groove recessed from the bore wall.

BRIEF DESCRIPTION OF THE DRAWINGS

A clearer understanding of this invention will be had from the following description given with reference to attached drawings illustrating diagrammatically by way of example two typical forms of embodiment of the invention. In the drawings :

FIG. 1 is a fragmentary longitudinal section showing a first form of embodiment of a cigarette-lighter reservoir according to the present invention ;

FIG. 2 is a longitudinal detail section showing the well of FIG. 1 before the insertion of the valve body into it, and

FIG. 3 is a view similar to FIG. 2 but showing a modified form of embodiment.

DESCRIPTION OF THE PREFERRED EMBODIMENTS

In the drawings, the reference numeral 2 designates a reservoir adapted to be filled with liquefied gas 3 as conventional in gas lighters, the upper portion of this reservoir 2 comprising a well 4 formed with a tapped portion 4a adapted to receive a correspondingly screw-threaded valve body 5. This valve body 5 made of suitable metal incorporates the valve member of which the projecting upper portion constitutes the burner 6.

According to this invention, the well 4 has an outer extension in the form of a cylindrical neck or skirt 7 also formed of plastic material, notably by injection-moulding. This neck 7 comprises an inner groove 8 formed substantially at the base thereof and adapted to impart a certain resiliency to this neck. The neck 7 further comprises on its inner portion extending from this groove to its outer edge a bore 9 having a bevelled upper edge 10. The diameter of bore 9 is slightly inferior to the outer diameter of the valve body 5.

Thus, when the valve body 5 is fitted by screwing into the well 4 it tends to produce a radial expansion of the neck 7 in the direction of the arrows 11 of FIG. 2. Thus, the neck 7 is caused to flare out in order to facilitate the introduction of the valve body while exerting by inherent resiliency a radial clamping effort in a direction opposed to that shown by the arrows 11.

As a result, the resiliency of neck 7 is sufficient for providing a fluid-tight engagement between the wall of

its bore 9 and the outer wall of valve body 5, and thus prevent any gas leakage between the valve body and the well.

In this specific form of embodiment, the neck 7 projects somewhat from the reservoir body 2, but it will readily appear to those skilled in the art that it can also be so formed that its upper face 12 be substantially coplanar with the corresponding face 13 of said reservoir, as illustrated in FIG. 3. In this case, the neck 7 is surrounded by a concentric groove 14 formed in the upper portion of the reservoir in order to preserve the inherent radial resiliency of said neck 7.

It will be noted that another advantage characterizing this elasticity of neck 7 is that during the manufacturing process and after the removal of the counterpart bounding its outer contour, the spindle or like tool necessary for machining the groove 8 can be extracted without difficulty ; now this step would not be possible if this resilient neck were not provided, since said groove is recessed with respect to the bore in the well.

Of course, this neck may also be formed integrally with the gas reservoir proper or with the cigarette-lighter body in case this body consisted of the reservoir itself.

It will readily appear to those conversant with the art that the present invention should not be construed as being strictly limited to the specific forms of embodiment described and illustrated herein by way of example, since many modifications and variations may be

brought thereto without departing from the basic principle of the invention as set forth in the appended claims.

What is claimed as new is

1. In a lighter body of the type wherein a plastic container for liquefied gas has a top integrally formed with a well for receiving a valve body which has valve means therein for controlling release of gas from the container to provide a flame, the improvement which comprises:

a. a tapped surface portion of the well, for engagement with a screw-threaded lower portion of the valve body, and

b. a neck, forming an integral extension of the container top, above and around said tapped surface portion, with

an inner, peripheral groove substantially at the base of said neck, and,

thereabove, an inner, cylindrical surface portion of said neck, for resilient inward engagement thereof, by virtue of said groove, with a slightly thicker, cylindrical, outer portion of the valve body,

whereby said inner cylindrical surface portion bears against said outer cylindrical portion and thus provides, by itself, a gas-tight seal for the valve body in the neck, while permitting movements of the screw-threaded valve body in the tapped well to adjust the length of the flame.

* * * * *

30

35

40

45

50

55

60

65