

Oct. 31, 1950

C. W. KRUEGER

2,527,679

DISPLAY SIGN

Filed Oct. 6, 1945

2 Sheets-Sheet 1

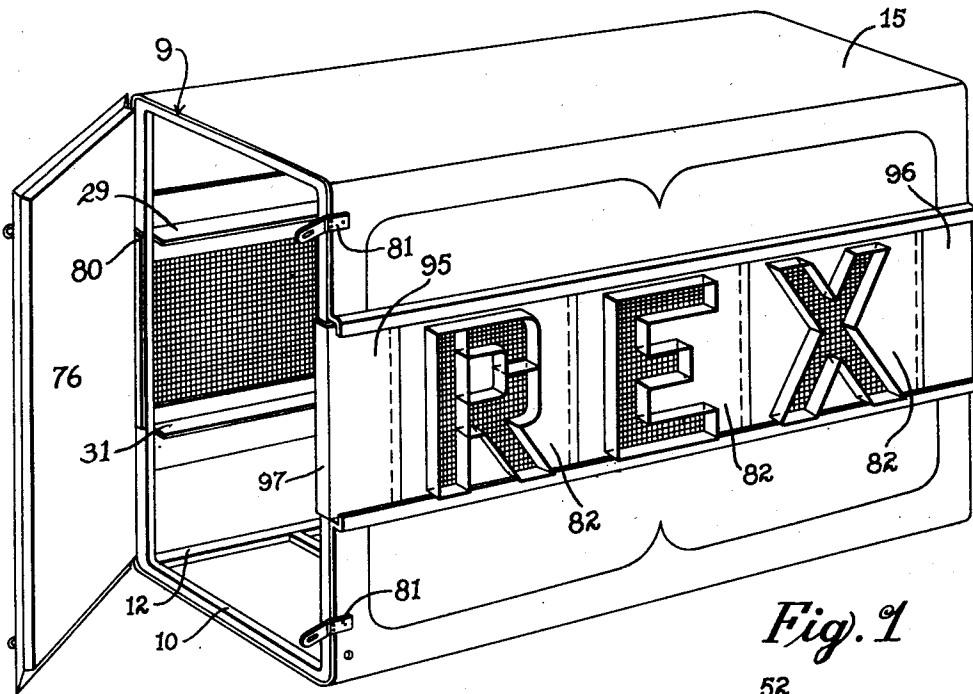

Fig. 1

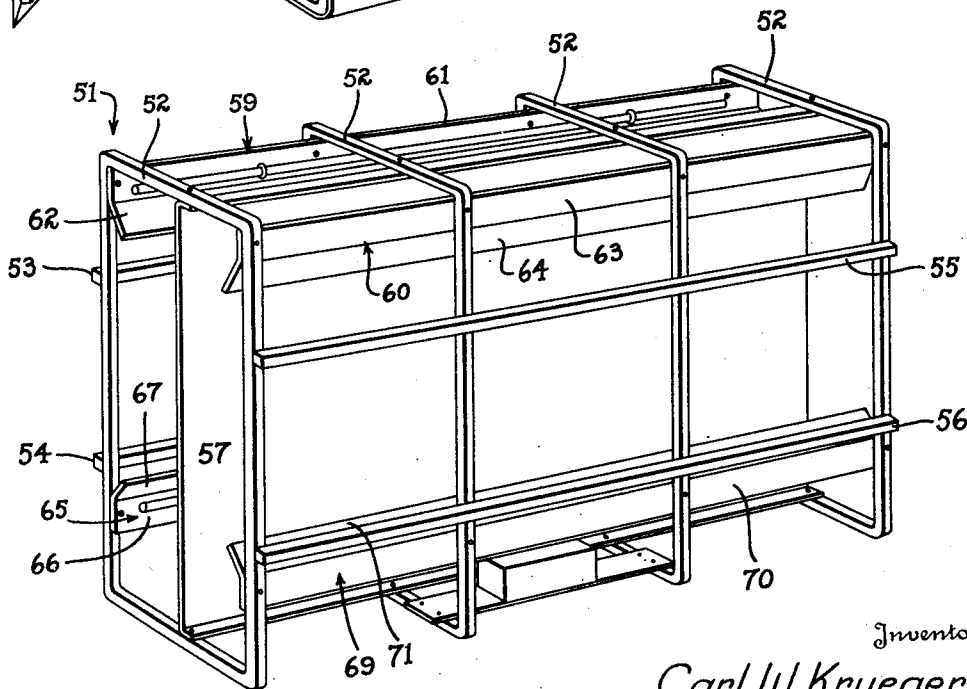

Fig. 2

354

Inventor
Carl W. Krueger
Robert M. Dunning
Attorney

Oct. 31, 1950

C. W. KRUEGER
DISPLAY SIGN

2,527,679

Filed Oct. 6, 1945

2 Sheets-Sheet 2

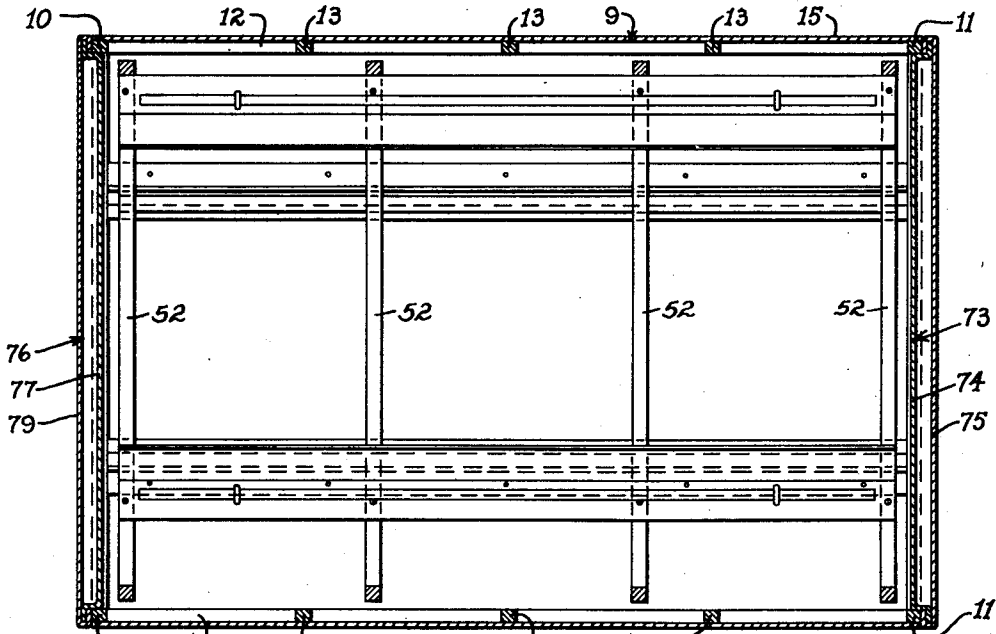

Fig. 3

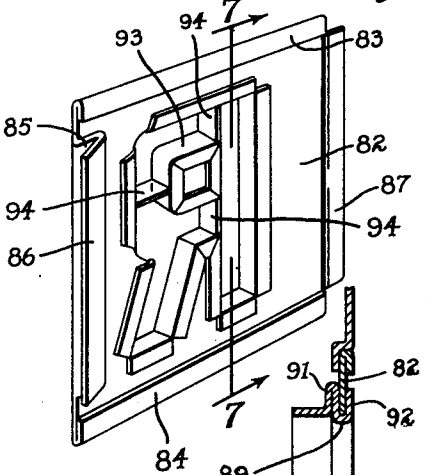

Fig. 6

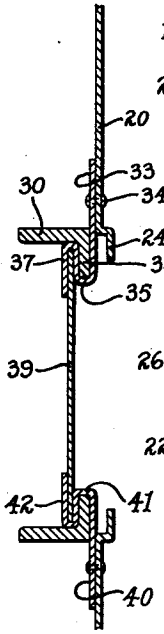

Fig. 5

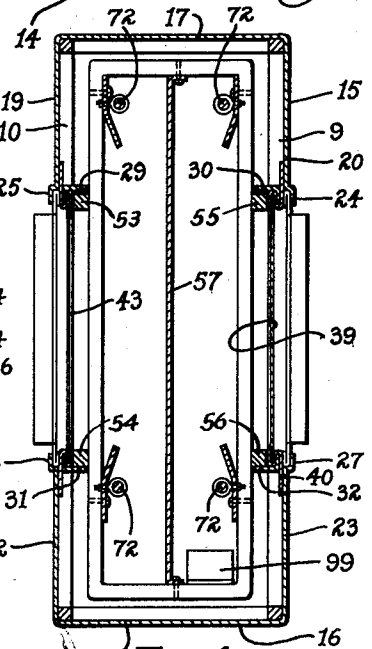

Fig. 4

Fig. 7

Inventor
 Carl W. Krueger
 Robert M. Dunning
 Attorney

UNITED STATES PATENT OFFICE

2,527,679

DISPLAY SIGN

Carl W. Krueger, South St. Paul, Minn.

Application October 6, 1945, Serial No. 620,799

6 Claims. (Cl. 40—140)

1

My invention relates to an improvement in display signs wherein it is desired to provide a sign clearly visible for a considerable distance.

During the past few years the use of signs formed of bent tubing containing neon or other gas has become common. These signs are inexpensive to operate and are visible for considerable distances. I have found, however, that as the distance from the sign increases the sign becomes less and less distinct. This is particularly true when there is considerable moisture in the air as the moist particles seem to reflect the light emitted and to blur the letters of the sign. Because of the illumination emitted in all directions from such signs the use thereof on many highways has been prohibited.

It is an object of the present invention to provide a sign which will be visible and distinct for a much greater distance than the neon signs usually used. By confining the light and preventing the light from being given off in all directions, much of the difficulty usually found in the use of neon signs may be eliminated. As a result this source of light may be used without the usual accompanying disadvantages.

It is an object of the present invention to provide a sign which may be produced in volume at low cost. My sign comprises an outer frame work formed in sections, any number of which may be attached together. These sections are covered to provide an open panel in one or both sides. Opaque panels having apertures there-through in the shape of desired letters or figures are supported in these open panels. When the interior of the enclosure is illuminated the light passes through the transparent apertures in the opaque panels to produce the desired sign.

A feature of the present invention resides in the provision of a sign having readily changeable letters. By the use of this structure, the wording of the sign may be quickly and easily changed.

A feature of the present invention resides in the manner of supporting the illuminating means within the interior of the sign. The outer frame work is provided with longitudinally extending guides therein. The inner frame work is slidably supported on these guides. The illuminating means is supported by the removable inner frame work. As a result repairs or replacements to the illuminating mechanism of the sign may be easily made by merely removing the inner frame work.

A feature of the present invention resides in the fact that no light from the illuminating means passes directly out of the outer enclosure. A light colored panel is placed behind the letters forming a part of the outer enclosure. Light is directed against this light colored panel. A person observing the sign may see this light colored panel through the letters or figures on the outer enclosure. As a result the sign gives off no aura of

2

light which is dangerous to traffic travelling along a highway at night.

A further feature of the present invention resides in the fact that each letter and figure forming a part of the outer enclosure is surrounded by a flange extending outwardly from the sign at substantially right angles to the surface thereof. These flanges act to direct the light and confine the light to the transparent or translucent areas of the opaque panels, thereby making the sign clear and distinct for considerable distances.

A further feature of the present invention resides in the fact that but little illumination is required to make the sign visible for a considerable distance. I have found that a single length of tubing containing neon or some other gas extending the length of the sign above and below the letters is sufficient to properly illuminate the sign. Thus I have found the sign extremely inexpensive to operate and maintain.

These and other objects and novel features of my invention will be more clearly and fully set forth in the following specification and claims.

In the drawings forming a part of my specification:

Figure 1 is a perspective view of the outer enclosure of my sign.

Figure 2 is a perspective view of the inner frame work of the sign.

Figure 3 is a sectional view through a section of the sign showing the inner and outer frame works in assembled relation.

Figure 4 is a transverse section through the sign showing the relationship of the parts.

Figure 5 is a sectional view of a detailed portion of the sign.

Figure 6 is a perspective view of one of the letters of the sign showing the construction thereof.

Figure 7 is a sectional view through the letter of Figure 6, the position of the section being indicated by the line 7—7 of Figure 6.

With reference now to Figures 1 and 3 of the drawings, it will be noted that the sign is provided with a closed outer container through which no light can escape except through the letters of the sign. The outer frame 9 includes a pair of rectangular frame members 10 and 11 which are connected by longitudinally extending frame members 12 connecting the various corners thereof, a series of cross members 13 arranged at spaced intervals between the longitudinally extending bars 12 between the top corners of the end frames 10 and 11. An open box like frame is thus produced which is rigid and light in weight.

An inverted channel-shaped top covering 15 encloses the upper portion of the outer frame 9 and a similar channel shaped covering 16 encloses

3

the lower portion of the outer frame 9. The cover 15 includes a top panel 17, a side wall panel 19, and a similar side wall panel 20. The bottom covering 16 includes a bottom panel 21, a side wall panel 22 and an opposite side wall panel 23. The covers 15 and 16 are spaced apart to provide an open area therebetween. As indicated in Figure 5 of the drawings, the marginal edge of each side wall panel is off-set. Figure 5 illustrates the lower edge of the panel 20 showing the off-set flange 24 thereupon. The lower edge of the wall panel 19 is provided with an off-set flange 25. The wall panel 22 is provided with an off-set marginal flange 26 while the opposite wall panel 23 is provided with an off-set marginal flange 27.

In order to provide a means of supporting the inner frame-work I provide angular guides extending from one end of the frame 9 to the other. A pair of opposed angle members 29 and 30 are connected to opposite sides of the rectangular frames 10 and 11 to connect the ends of the frame 9. A second pair of opposed angular frame members 31 and 32 are secured between the rectangular end frames 10 and 11. The inner frame is supported as will be later described between these angles 29, 30, 31, and 32, and is slidably supported thereby. As illustrated in Figure 4 of the drawings and as shown more clearly in detail in Figure 5 of the drawings, a transparent member closes the space between the upper and lower coverings 15 and 16. A strip of sheet metal 33 is secured to the lower extremity of each of the side walls 19 and 20 by any suitable means such as the bolts or rivets 34. The strip 33 extends beneath the adjacent angle member 30 and is bent to enclose the vertical flange of the angle member. As seen in Figure 5 a channel 35 of the strip 33 embraces the vertical flange 36 of the angle member 30 and is bent to form an inverted channel 37 to embrace the upper marginal edge of the transparent sheet 39. In preferred form the sheet 39 is comprised of screen filled with transparent plastic or the like to form a continuous film. This material is preferred due to its strength as well as its transparency, and further due to the fact that it is relatively non-breakable. Other similar transparent members can be substituted for this particular material, however.

The lower edge of the transparent member 39 is supported by a strip 40 similar to the strip 33, but reversed with respect thereto. The strip 40 is formed with a channel 41 to enclose the vertical flange of the angle 32 and with a channel 42 to enclose the lower end of the transparent member 39. Thus a water tight barrier is provided to protect the interior of the sheet.

A transparent member 43 is supported between the side walls 19 and 22 as best illustrated in Figure 7 of the drawings. A strip 44 is secured to the lower edge of the panel 19. This strip 44 is bent to provide a channel 45 enclosing the vertical flange of the angle member 29 and is bent to provide a channel 46 to enclose the upper marginal edge of the transparent member 43. A similar strip 47 is secured to the lower wall panel 22. This strip 47 is bent to provide a channel 49 providing the vertical flange of the angle 31 and is likewise provided with a channel 50 to enclose the lower marginal edge of the transparent member 43.

With reference now to Figures 2, 3, and 4 of the drawings, it will be noted that the inner frame 51 comprises merely a shell for supporting the illuminating means which is removable bodily

4

from the outer frame 9. The inner frame 51 comprises a series of spaced rectangular frame members 52 which are connected by longitudinally extending frame members 53, 54, 55, and 56. A central reflector panel 57 is connected between the top and bottom ends of the rectangular frames 52, mid-way between the sides of the frame. Upper shields 59 and 60 are arranged in opposed relation at the top of the frame to direct light inwardly toward the center shield or panel 57. The shield 59 comprises a vertical panel 61 and inwardly and downwardly inclined flange 62 attached thereto. The shield 60 likewise comprises a vertical panel 63 having inwardly and downwardly inclined panel 64.

A pair of light shields are likewise secured to the frame members 52 near the bottom ends thereof. The shield 65 includes a vertical panel 66 and an inwardly and upwardly inclined panel 67. The shield 69 includes a vertical panel 70 and an inwardly and upwardly inclined panel 71. These panels 65 and 69 direct the light toward the central shield or panel 57.

As best illustrated in Figure 4 of the drawings an elongated gas containing illuminating tube 72 is secured to the inner frame inwardly of each of the shields 59, 60, 65 and 69. These tubes 72 are so arranged that the adjacent shields prevent light therefrom from passing directly out through the transparent members 39 and 43. The light is directed against the central panel or shield 57 to brightly illuminate the same.

An end enclosure 73 is bolted or otherwise affixed to one end of the outer frame 9. The enclosure 73 comprises inner and outer spaced panels 74 and 75 marginally connected together and fitting within the frame 11 with a plug fit. A similar end closure 76 is hinged to the opposite end of the outer frame 9. This enclosure 75 includes an inner panel 77 and an outer panel 79 marginally secured together and fitting within the frame 10 in the manner of a plug. The closure 76 is hinged by the hinge 80 as illustrated in Figure 1 of the drawings and may be held in closed position by locking hasps 81. Each transparent member 39 and 43 is covered by a series of opaque panels slidably supported between the off-set flanged edges of the side walls and the adjacent strips. The letters are formed as best illustrated in Figures 1, 6, and 7 of the drawings. Each panel 82 is provided with a flanged upper edge 83 turned back upon itself, and a flanged lower edge 84 turned back upon the panel to overlies the marginal edge thereof. A channel is formed in one end of each panel 82 by folding the sheet material back upon itself at 85 and providing a marginal flange 86 substantially parallel to the body of the panel. A tongue 87 on the edge of the panel opposite the channeled edge may fit into the channel of the next adjacent panel, thus providing an interlocking panel arrangement. In producing the various letters I prefer to first cut an aperture such as 89 in the panel 82 which is the outline shape of the letter or figure to be produced. A marginal rim or flange 90 is then bent to extend around the outline of the letter. A double flange 91 on this rim or guard overlies the outer surface of the panel 82. A single marginal flange 92 overlies the inner surface of the panel 82. At the corners of the letters the double flange 91 and the single flange 92 are cut or mortised to provide a continuous guide around the outside of the letter.

Certain of the letters having central opaque portions spaced from any marginal edge of the

5

aperture 89 are provided with a second guard or rim 93 held in spaced relation to the outer guard 90 by connecting webs 94. Thus each letter is outlined by a shield or guard extending outwardly from the face of the sign and of sufficient depth to clearly define the light passing through the letter.

In the event the letter panels 82 do not completely cover the transparent member inwardly thereof, blank end panels such as 95 and 96 may be employed to complete the closure. The blank end panels 95 and 96 are shaped at their end to interlock with the adjacent panels 82 and these panels are provided with an end flange 97 which extends over the end of the sign to be locked between the closure 76 and the adjacent end of the outer enclosure. Thus the various letters are locked in place when the closure 76 is pivoted into closed position.

The transformer usually required in conjunction with signs of this type is indicated diagrammatically at 99. This transformer is connected to a suitable supply of electrical current and is likewise connected to the various tubes 72. As the transformer 99 is mounted upon the inner frame 51, it is removable therewith so that the electrical connections may be checked from time to time by merely removing the interior of the sign.

In accordance with the patent statutes, I have described the principles of construction and operation of my sign, and while I have endeavored to set forth the best embodiments thereof, I desire to have it understood that obvious changes may be made within the scope of the following claims without departing from the spirit of my invention.

I claim:

1. A display sign comprising an elongated frame having upper and lower covering members therefor, translucent means supported between said upper and lower coverings through which light may pass, guides secured to the marginal edges of said upper and lower coverings, a second frame slidably supported within said first mentioned frame and including side rails engageable with said guides, a central flat reflecting panel supported by said second frame, and illuminating means supported by said second frame above and below said translucent members and spaced substantially from the plane of the central panel to direct light against said central reflecting panel.

2. A sign comprising an outer enclosing frame having light apertures therethrough, an inner frame slidably supported thereby, means on opposite sides of the outer frame for suspending said inner frame, a flat reflecting panel supported by said inner frame, light producing means supported by said inner frame above and below said light apertures and near said opposite sides of the outer frame, said reflecting panel being positioned inwardly of said light apertures and in position to reflect light from said light producing means.

3. A display sign comprising a cabinet having a pair of opposed elongated apertures therein through which light may pass, a series of apertured panels removably secured in said elongated apertures, a frame supporting said panels, an inner frame removable within said first mentioned frame, a panel supported between said elongated apertures by said inner frame, and

6

tubular illuminating means supported upon said inner frame above and below said elongated apertures and spaced substantially from the plane thereof to direct light against said panel.

4. A display sign including a series of spaced rectangular frames, longitudinally extending means connecting said frames to hold the same in spaced relation, a pair of channel shaped housing members secured to said rectangular frames and extending longitudinally with respect thereto, one of said channel shaped members enclosing the top and adjacent portions of the front and rear sides of the frame, and the other of said channel shaped members enclosing the bottom and adjacent portions of the sides of the frame, and closures for the sign, the sides of the two channel shaped members terminating in spaced relationship, a translucent member between the opposed sides of said channel shaped member to complete the enclosure of the frames, a pair of longitudinally extending frame members projecting inwardly from the marginal edges of the two channel shaped housing members, an inner frame including a series of longitudinally spaced rectangular frame members, a pair of longitudinally extending members connecting said rectangular frame members and holding the same in spaced relationship, said last named longitudinally extending members being provided on each side of said rectangular frame members and being spaced to extend between the angle members extending inwardly from the outer frame, an illuminating means supported by said inner frame, and a panel extending vertically between the top and bottom ends of said rectangular frame members of said inner frame between the sides thereof.

5. The structure described in claim 4 in which the illuminating means are located above and below the translucent portions of said frame to direct light against said panel.

6. The structure described in claim 4 and including a series of removable letters slidably supported between said opposed housing members to overlie said translucent members.

CARL W. KRUEGER.

REFERENCES CITED

The following references are of record in the file of this patent:

UNITED STATES PATENTS		
Number	Name	Date
593,433	Reynolds	Nov. 9, 1897
696,462	Markstrom	Apr. 1, 1902
1,091,893	Ricke	Mar. 31, 1914
1,118,866	Jones	Nov. 24, 1914
1,256,533	Duck	Feb. 19, 1918
1,271,044	Leech	July 2, 1918
1,352,031	Schaffner	Sept. 7, 1920
1,469,396	Schilling	Oct. 2, 1923
1,492,472	Leech	Apr. 29, 1924
1,538,348	Norden	May 19, 1925
1,583,912	Beswicke	May 11, 1926
1,602,892	Frank	Oct. 12, 1926
1,654,337	Lowinger	Dec. 27, 1927
1,784,677	Morton	Dec. 9, 1930
1,791,241	Hotchner et al.	Feb. 3, 1931
1,792,635	Gropper	Feb. 17, 1931
1,797,322	Callender	Mar. 24, 1931
1,916,852	Sutton	July 4, 1933
1,988,555	Harase	Jan. 22, 1935
2,260,462	Ganoung	Oct. 28, 1941