

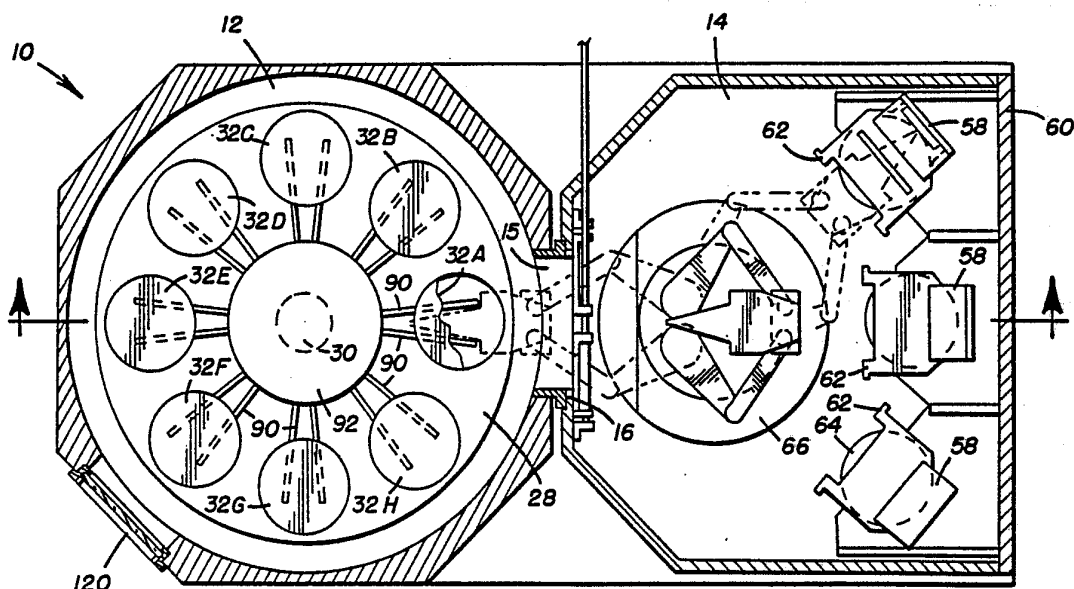

INTERNATIONAL APPLICATION PUBLISHED UNDER THE PATENT COOPERATION TREATY (PCT)

<p>(51) International Patent Classification⁴ : C23C 16/00</p>	<p>A1</p>	<p>(11) International Publication Number: WO 87/ 07309 (43) International Publication Date: 3 December 1987 (03.12.87)</p>
<p>(21) International Application Number: PCT/US87/01176 (22) International Filing Date: 18 May 1987 (18.05.87) (31) Priority Application Number: 865,074 (32) Priority Date: 19 May 1986 (19.05.86) (33) Priority Country: US (71) Applicant: NOVELLUS SYSTEMS, INC. [US/US]; 3350 Scott Boulevard, Building 1, Santa Clara, CA 95054 (US). (72) Inventor: WESTRATE, Stephen, Blakely ; 136 Los Trancos Circle, Portola Valley, CA 94025 (US). (74) Agents: WATT, Phillip, H. et al.; Fitch, Even, Tabin & Flannery, Room 900, 135 South LaSalle Street, Chica- go, IL 60603 (US).</p>		<p>(81) Designated States: AT (European patent), BE (Euro- pean patent), CH (European patent), DE (European patent), FR (European patent), GB (European pa- tent), IT (European patent), JP, LU (European pa- tent), NL (European patent), SE (European patent).</p> <p>Published <i>With international search report.</i></p>

(54) Title: DEPOSITION APPARATUS WITH AUTOMATIC CLEANING MEANS AND METHOD OF USE



(57) Abstract

A deposition apparatus (10) comprising two chambers, a reaction chamber (12) and a load lock wafer storage chamber (14) separated by a remotely controlled door (16) or access port (15). Chemical vapor deposition processing and dry etch cleaning of the reaction chamber are performed alternatively during normal operation of the deposition apparatus. Wafers on which a layer is being deposited are transported from the load lock automatically to the reaction chamber for processing and thereafter returned to the load lock. A plurality of wafers (64) may be stored in the load lock for processing. Access to the load lock is via an external door (60) when the load lock has been backfilled to external atmosphere. Cleaning of the reaction chamber takes place during the wafer exchange time.

FOR THE PURPOSES OF INFORMATION ONLY

Codes used to identify States party to the PCT on the front pages of pamphlets publishing international applications under the PCT.

AT	Austria	FR	France	ML	Mali
AU	Australia	GA	Gabon	MR	Mauritania
BB	Barbados	GB	United Kingdom	MW	Malawi
BE	Belgium	HU	Hungary	NL	Netherlands
BG	Bulgaria	IT	Italy	NO	Norway
BJ	Benin	JP	Japan	RO	Romania
BR	Brazil	KP	Democratic People's Republic of Korea	SD	Sudan
CF	Central African Republic	KR	Republic of Korea	SE	Sweden
CG	Congo	LI	Liechtenstein	SN	Senegal
CH	Switzerland	LK	Sri Lanka	SU	Soviet Union
CM	Cameroon	LU	Luxembourg	TD	Chad
DE	Germany, Federal Republic of	MC	Monaco	TG	Togo
DK	Denmark	MG	Madagascar	US	United States of America
FI	Finland				

-1-

DEPOSITION APPARATUS WITH AUTOMATIC CLEANING MEANS
AND METHOD OF USEBackground of the Invention

The present invention relates to an apparatus and method for automatic cleaning of a reaction chamber used in the chemical vapor deposition of films on semiconductor substrates, and more specifically to an apparatus which automatically isolates the reaction chamber during loading and unloading of specimens so as to enable concurrent cleaning of the reaction chamber.

Chemical vapor deposition (CVD) is commonly used to form a layer or film of material on a substrate or other surface of a specimen, typically a silicon wafer. The layer or film can be silicon dioxide, silicon nitride, polysilicon, etc. In CVD processes, a gaseous material is dispersed over the surface of the wafer while being heated and/or an RF induced plasma is used. The heated gas impacts on the surface of the wafer where it undergoes chemical reactions and becomes deposited on the surface.

Prior art CVD reaction chambers have been of many types, e.g. horizontal systems, where wafers are placed on a wafer holder and gas flows in one end of a quartz tube containing the wafers, the gas flowing across the wafers and out the other end; cylindrical, or barrel systems, where wafers are placed on an outer surface of a cylinder and gas flows into the chamber from the side; and gas-blanketed downflow systems, where gas flows downward on the wafers which are mounted on a horizontal surface.

An undesirable byproduct of the CVD process is that the reaction chamber surrounding the wafer on which the film is deposited also is deposited on and the chamber therefore must be routinely cleaned. Unless periodically cleaned, the reaction material deposited on the walls of the reaction chamber can contaminate the wafer during processing and interfere

-2-

with the normal growth and coating of a desired film. This can have a severe impact on film defect density.

A number of prior art techniques are known for periodically cleaning CVD reaction chambers to remove the deposited films and residue. What is typically done in prior systems is that the reaction chamber is completely disassembled and then wiped down or dipped in an acid bath or otherwise wet etched to remove the undesired deposits from the surface of the reaction chamber. A solution of hydrofluoric and nitric acid is commonly used in such wet etch processes. The disadvantage of this technique is that the reaction chamber cannot be cleaned in situ, the entire apparatus must be disassembled for cleaning. System downtimes of up to 24 hours are common. This significantly adversely effects the throughput of the apparatus.

A method for cleaning a reaction chamber is disclosed in U.S. Patent No. 4,576,698 wherein plasma etch removal of deposition materials built up in a deposition chamber is enabled in situ. In this method, an RF electrode is placed in the center of the chemical vapor deposition chamber. A cleaning gas is then introduced into the chamber to etch clean the chamber walls. By exciting the cleaning gas with a plasma generated by the RF electrode within the quartz tube chamber, the system is cleaned without necessitating complete disassembly. A similar method of plasma enhanced cleaning of a CVD reaction chamber is disclosed in U.S. Patent No. 4,138,306. In this apparatus, the step of cleaning the reaction chamber using a plasma enhanced dry etch process is built into the apparatus.

A key problem with the above cleaning techniques is that the described cleaning processes interrupt the normal operation of the deposition apparatus. This is of critical importance in

-3-

modern-day deposition processing wherein it is desirable to maximize the number of wafers that can be processed per unit of time in a given deposition reaction chamber.

5

Summary of the Invention

It is therefore an object of the present invention to provide an improved deposition apparatus which enables the automatic cleaning of the deposition reaction chamber concurrent to the normal operation of the deposition apparatus.

10

Another object of the present invention is to provide a deposition apparatus which maximizes throughput and cleanliness by providing automatic batch processing of multiple wafers without contamination of the reaction chamber with a wafer carrier or with contact to external atmosphere.

15

These and other objects of the present invention will become apparent to those skilled in the art from the following detailed description of the invention and the accompanying drawings.

20

Broadly stated, the present invention consists of two vacuum chambers, a reaction chamber and a load lock wafer storage chamber, which are separated by a remotely controlled door or access port. Means are provided for alternatively introducing gas materials into said reaction chamber for CVD processing and for dry etch cleaning of the reaction chamber. Automatic transport means are provided for transporting wafers from the load lock to said reaction chamber and for returning said wafers to the load lock from the reaction chamber after completion of the deposition process. An external door is provided for access to the load lock.

25

30

The advantage of the present invention is that it enables increased throughput because the reaction chamber does not need to be pumped down for each

35

-4-

deposition process, since the wafers are prepumped to the desired low pressure in the load lock. In prior art devices, there has been an effective dead time during the time that wafers are exchanged in the load lock. This dead time is used by the reaction chamber according to the present invention for automatic cleaning. After the reaction chamber has been cleaned and the wafers have been exchanged in the load lock, the two chambers are stabilized in pressure so they can again act in unison to perform wafer deposition processing. RF field generating means may be included in the reaction chamber to enhance the cleaning and/or the deposition processing performed in the reaction chamber.

15 Brief Description of the Drawings

FIGURE 1 is a partially schematic cross-sectional view of a deposition apparatus according to the present invention taken along line 1-1 of FIGURE 2.

20 FIGURE 2 is a top cross-sectional view of the reaction chamber and load lock shown in FIGURE 1, taken along line 2-2.

FIGURES 3A-3D illustrate the operation of the wafer transport means according to the present invention.

25 FIGURE 4 illustrates the operation of the access port between the load lock and the reaction chamber and the operation of the external door to the load lock.

30 FIGURE 5 illustrates a timing diagram of the operation of a deposition apparatus according to the present invention.

Detailed Description of the Preferred Embodiment

A preferred embodiment of a deposition apparatus is shown in FIGURE 1 at 10. Apparatus 10 includes a reaction chamber 12 and a load lock 14.

-5-

Access between reaction chamber 12 and load lock 14 is by means of a passageway or access port 15, one end of which is selectively sealed by remotely controlled door 16. Reaction chamber 12 is of a conventional type for enabling chemical vapor deposition processing of specimens therein.

Many CVD processes require low pressure, so means are required for evacuating reaction chamber 12. A conventional vacuum pump 18 is used for this purpose. Reaction chamber 12 is connected to a vacuum pump 18 by means of one or more conduits 20 and 22 for maintaining a desired level of vacuum in reaction chamber 12. Respective valves 24, 26 are used to control connection of vacuum pump 18 to conduits 20 and 22. Vacuum pump 18 must be large enough to provide a sufficient rate of evacuation and a sufficient degree of vacuum in reaction chamber 12, for example, 0.5-1.0 Torr, to enable both CVD processing and dry etch processing in reaction chamber 12.

Reaction chamber 12 according to the preferred embodiment includes multiple deposition stations on a table 28. As best seen in FIGURE 2, which is a top view of deposition apparatus 10, eight wafer stations, 32A to 32H, are preferably included on the top of table 28. Means are also provided for sequentially moving a specimen at one station to the next station in sequence. As described in greater detail below, a specimen is initially loaded onto station 32A. After processing at all eight stations, it is removed from table 28 at the same station 32A. Movement of a specimen between stations may be performed by mounting table 28 on a spindle 30 which functions to cause table 28 to rotate. Alternatively, fingers may be used for this movement function, as hereinafter described.

Referring again to FIGURE 1, reactant gas materials are supplied to each wafer station 32A-32H by

-6-

means of associated disc shaped gas discharge heads 34A-34H, of which 34A-34E are shown. Reactant gas is supplied to gas discharge heads through a conventional conduit 36. Conduit 36 is split into a plurality of
5 conduits 37 for supplying of reactant gas to each of said gas discharge heads 34A-34H. Conventional CVD gas from a source of such gas 38 is supplied to conduit 36 via valves 40 and 42 and conduit 44. Similarly, etchant gases provided from a source of such gas 46 is
10 supplied to conduit 36 via valves 48 and 42 and conduit 50.

The vacuum in load lock 14 may also be controlled by vacuum pump 18 by means of a valve 52 and conduit 54. Thus, vacuum pump 18 provides, in a
15 conventional manner, means for enabling the load lock 14 to be evacuated a predetermined amount so as to match the vacuum in reaction chamber 12. A "load lock", as shown at 14, is a term known in the art as a prechamber which isolates a reaction chamber from
20 atmospheric conditions to prevent entry of contamination into the reaction chamber. In an apparatus that uses a load lock, it is common for the reaction chamber to always have a vacuum maintained therein.

A conventional RF generator 60 is preferably
25 provided according to the present invention to generate a plasma at each wafer station 32A-32H. In the present embodiment, the hot electrode of the RF generator is formed by the gas discharge heads 34A-34H, with the ground return for the plasma being provided by table
30 28. This enables localized deposition of film in the areas of interest at each station while minimizing deposition on the walls of the reaction chamber outside of this localized area.

Included within load lock 14 is a means 58 for
35 removably mounting a wafer cassette or carrier. Carrier mounting means 58 is preferably part of a door

-7-

60 which provides external access to load lock 14. When access door 60 is open, a wafer cassette 62, containing a plurality of wafers 64 to be processed by the deposition apparatus 10, is mountable in mounting means 58.

With reference again to FIGURE 2, a preferred embodiment of the present invention includes a plurality of wafer carriers 62 mountable in mounting means 58 in door 60. As described in greater detail below, this enables the apparatus 10 to take wafers 64 from a first cassette 62 for processing and, once processing is completed to replace the wafers in a second cassette. This can be advantageous, for example, where one wishes to eliminate any mechanical device movement above any wafer once a film has been deposited on the wafer. With an empty cassette available, wafers can be removed from one cassette from the bottom up and returned to an empty cassette starting at the top.

A wafer transport means 66 is included in load lock 14 to provide means for transporting individual wafers from a cassette 62 to the reaction chamber 12 for deposition processing and later for returning each wafer to a specific location in cassette 62 or in an adjacent cassette upon completion of the deposition processing.

The operation of the wafer transport means is best seen with reference to FIGURES 3A-3D. These figures illustrate an exemplary transfer of a wafer from a wafer cassette 58 past door 16 through access port 15 to wafer station 32A. Referring first to FIGURE 3A, wafer transport means 66 includes two arms, a first arm 67 and a second arm 68 connected at one end to a spindle means 82 and at their other end to a wafer transport table 84. First arm 67 includes an upper arm portion 70 connected to spindle 82, a lower arm portion

-8-

72 connected to wafer transport table 84 and an elbow pivot interconnecting arm portions 70 and 72. Second arm 68 includes an upper arm portion 76 connected to spindle 82, a lower arm portion 78 connected to wafer transport table 84 and an elbow pivot 80 interconnecting arm portions 76 and 78.

Spindle 82 provides three types of motion for positioning wafer transport table 84 within load lock 14 and reaction chamber 12. These include the rotation of arms 67 and 68 about a vertical axis 86, the rotation of arms 70 and 76 with respect to spindle 82 so as to provide telescoping of the wafer transport table 84 with respect to spindle 82, and means for raising and lowering spindle 82, and thus transport table 84, with respect to the bottom surface of load lock 14.

In operation, therefore, the wafer transport means 66 positions the wafer transport table 84 at a vertical height beneath a wafer to be placed on table 84. As illustrated in FIGURE 1, once the wafer table 84 is positioned beneath a selected wafer 64, spindle 82 rises vertically a predetermined amount to lift the wafer 64 off of cassette 62 such that it is resting entirely on table 84. As illustrated in FIGURE 3B, arms 70 and 76 are rotated so as to draw in wafer table 84 towards the axis 86 of spindle 82 and spindle 82 is rotated so as to position table 84 for insertion through access port 15 as seen in FIGURE 2. As shown in FIGURE 3C, the arms 70, 76 are further pivoted to cause table 84 to move through access port 15 and into reaction chamber 12.

FIGURE 3D illustrates the placing of wafer 64 in wafer station 32A. Transfer of wafer 64 onto work station 32A from table 84 is facilitated by means of fingers 90 connected to a central plate 92. Plate 92 is displaced vertically in a conventional manner once

-9-

wafer 64 is in position over wafer station 32A at the same elevation as wafer transport table 84. Spindle 82 then is displaced vertically downward so as to cause wafer 64 to rest solely on fingers 90. Wafer table 84 is then withdrawn from beneath wafer 64 in the manner reverse to the above described operation. Plate 92 is then vertically displaced downward causing fingers 90 be positioned in recesses 94 thereby enabling wafer 64 to securely rest on wafer transport station 32A.

Plate 92 and fingers 90 may also provide means for moving wafers being processed from one station 32 to the next. Instead of rotating table 28, spindle 30 may be coupled to plate 92 for rotation of plate 92, and thereby fingers 90, with respect to table 28.

FIGURE 4 illustrates the operation of the access door 16 between load lock 14 and reaction chamber 12 and similarly the operation of external door 60. Although FIGURE 4 illustrates both door 16 and 60 in an open condition, according to a preferred embodiment of the invention it is desired that reaction chamber 12 never be opened to atmosphere during normal operation. Consequently, whenever door 60 is open, door 16 should be closed to maintain reaction chamber 12 isolated from the exterior environment and maintained at a desired vacuum. Door 16 is operable in a conventional manner by means of a cylinder piston 100 pivotally connected to door 16 at 102. As piston 100 extends, door 16 is caused to pivot about pivot point 104. A conventional O-ring seal 106 may be provided to ensure sealing of door 16 against the surface of load lock 14 when door 16 is in its closed position.

A cylinder and piston 110 is also used in the operation of external door 60. Seen in FIGURE 4, piston 110 is connected to a pivot point 112 on external door 60 so as to cause door 60 to open about pivot point 114 to enable external access to load lock

-10-

14 and the wafer cassette mounting means 58 in door 60. An O-ring seal 116 may be included for sealing of external door 60.

5 For ease of monitoring of the deposition process in the deposition apparatus 10 according to the present invention, one or more viewing windows 120 may be formed in the side of reaction chamber 12.

10 FIGURE 5 illustrates a timing diagram of the operation of a deposition apparatus according to the present invention. The operation of deposition apparatus 10 is completely automatic. An operator simply inserts two filled wafer cassettes 62 in respective wafer mounting means 58 in external door 60. A third wafer cassette location shown in FIGURE 2 is
15 maintained with an empty cassette so that once wafers have been processed in reaction chamber 12, they can be returned to the empty cassette in a manner so as to minimize wafer contamination. Once the external door 60 is closed, the load lock is evacuated by vacuum pump
20 18 to bring the load lock to the same pressure as existing in the reaction chamber 12. Each wafer is then processed sequentially in the eight wafer stations 32A-32H and then returned to the wafer cassette 62 being filled with the processed wafers. All wafer
25 loading and unloading steps are performed using the wafer transport means 66. As each wafer is removed from wafer station 32A, a new wafer is obtained and put in its place to maintain a full load of wafers on table 28 in the reaction chamber 12. This processing is
30 continued until all wafers in the cassettes 62 are processed.

Upon completion of deposition processing, door 16 is closed and load lock 14 is backfilled to atmosphere. Once atmosphere is reached, external door
35 60 is opened and the processed wafers are exchanged with new wafers for processing. During this backfill

-11-

and wafer exchange time, reaction chamber 12 is automatically proceeding with a dry etch cleaning process to remove all debris and residue remaining in the reaction chamber 12 as a result of the previous deposition process. As the load lock 14 is being pumped down again to match the vacuum in reaction chamber 12, the cleaning gases are exhausted from reaction chamber 12.

In one alternate embodiment of the etch cleaning process, a two-step clean can be performed. It is preferable that a high rate dry etch be performed in the area where the deposition process took place and is preferably enhanced using well known plasma enhancing techniques. Secondly, a plasma etch of the entire process chamber is then performed at lower pressure to ensure that the entire chamber is clean of residue.

Various modifications to the present invention will become apparent to those skilled in the art from the foregoing description and accompanying drawings. Such modifications are intended to fall within the scope of the appended claims.

-12-

WHAT IS CLAIMED IS:

1. In a deposition apparatus for forming a layer of material on a specimen in a low pressure reaction chamber, means for enabling the automatic cleaning of said reaction chamber comprising: load lock
5 means; means for evacuating said load lock so as to match the pressure in said reaction chamber; access means connecting said load lock to said reaction chamber for selectively allowing passage therebetween; means for selectively introducing gas materials into
10 said reaction chamber for CVD processing; means for selectively introducing gas materials into said reaction chamber for etch cleaning of said reaction chamber; transport means for transporting specimens from said load lock to said reaction chamber via said
15 access means for deposition processing and for returning said specimens to said load lock via said access means upon completion of said deposition processing; and means for external access to said load lock.

20 2. The deposition apparatus of Claim 1 wherein said load lock includes means for mounting a plurality of specimens each individually accessible by said transport means.

25 3. The deposition apparatus of Claim 1 further comprising means for generating a plasma field in said reaction chamber.

30 4. The deposition apparatus of Claim 1 wherein said reaction chamber further includes: a plurality of specimen stations; and means for sequentially moving each said specimen from one said station to the next; said transport means including means for loading said specimen onto a first such station at the beginning of said sequence and for removing a specimen from the last such station in said

-13-

sequence.

5. In a deposition apparatus including a reaction chamber for performing chemical vapor deposition of a layer of material on a specimen, a method for cleaning said reaction chamber comprising the steps of: moving said specimen from said reaction chamber into said load lock; closing the access port between said reaction chamber and said load lock; introducing gas materials into said reaction chamber for etch cleaning of said reaction chamber; backfilling said load lock to atmosphere; exchanging said specimen in said load lock; evacuating said load lock so as to match the pressure in said reaction chamber; exhausting said etch cleaning gas materials from said reaction chamber; opening said access port between said load lock and said reaction chamber; and moving said specimen into said reaction chamber.

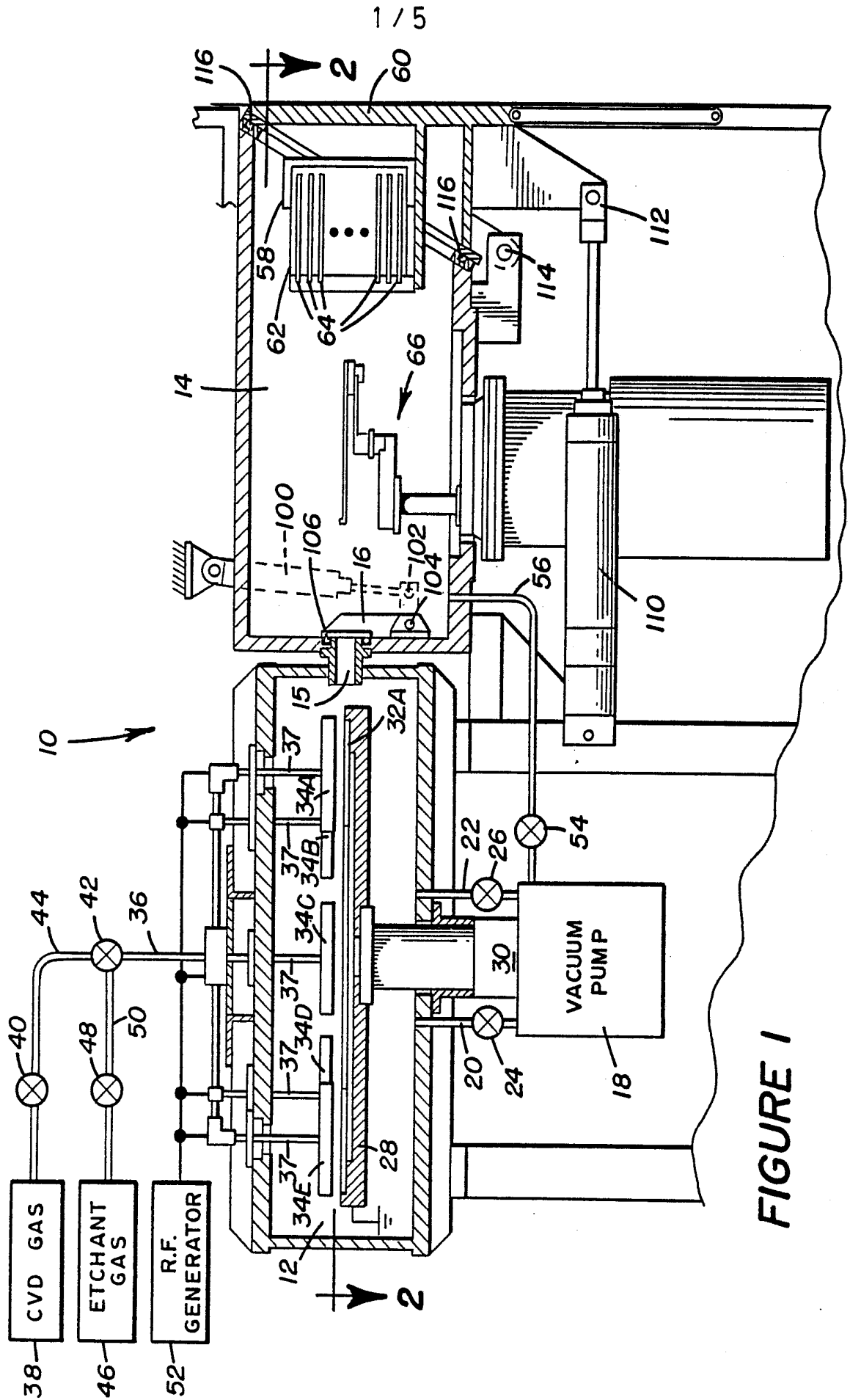

FIGURE 1

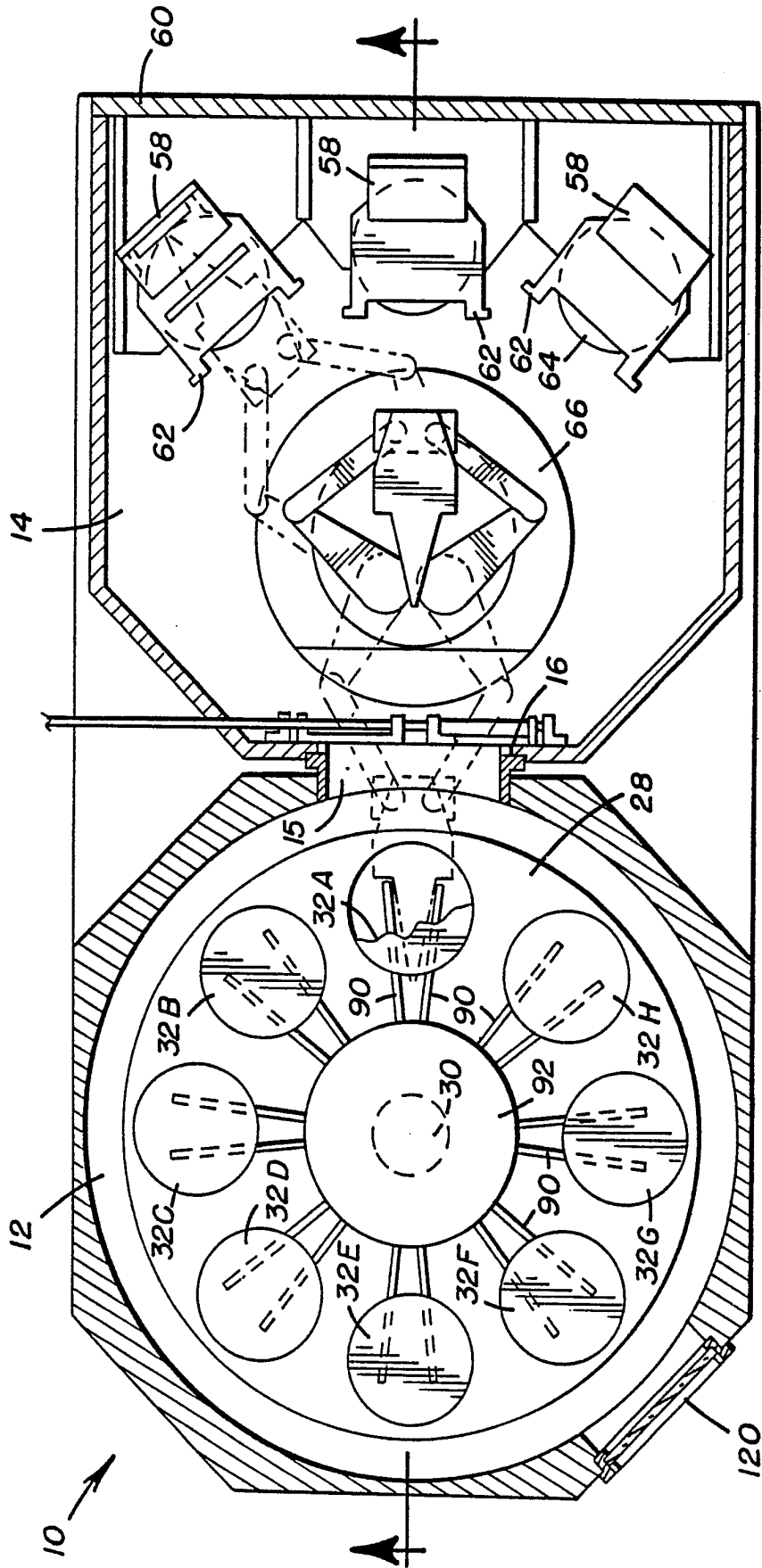

FIGURE 2

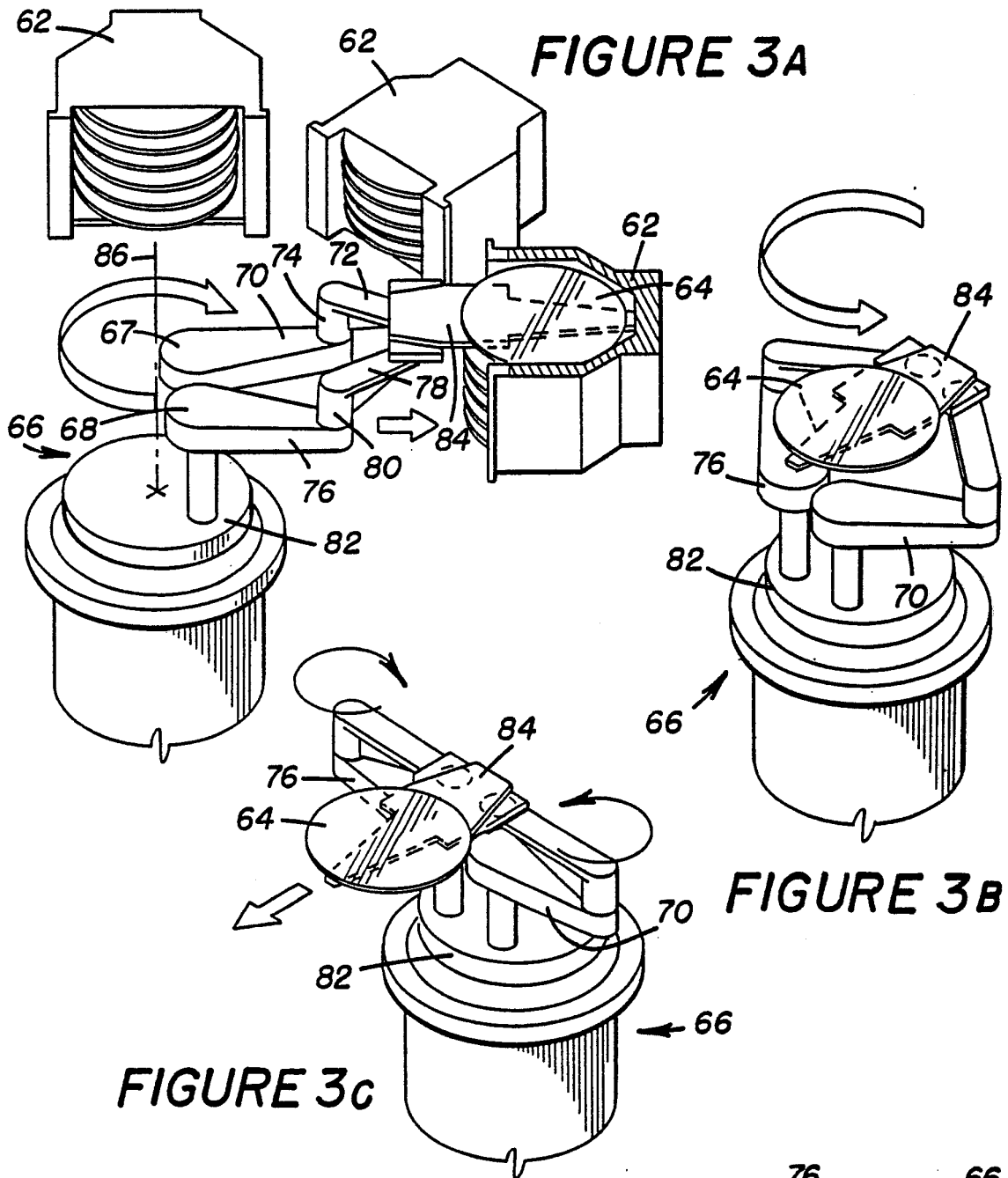

FIGURE 3C

FIGURE 3B

FIGURE 3A

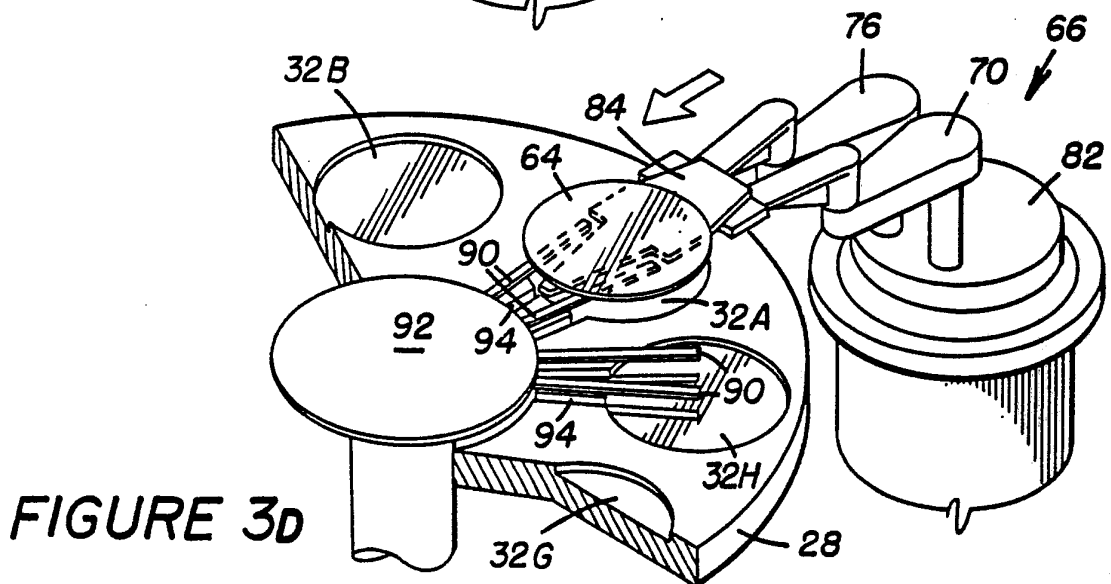

FIGURE 3D

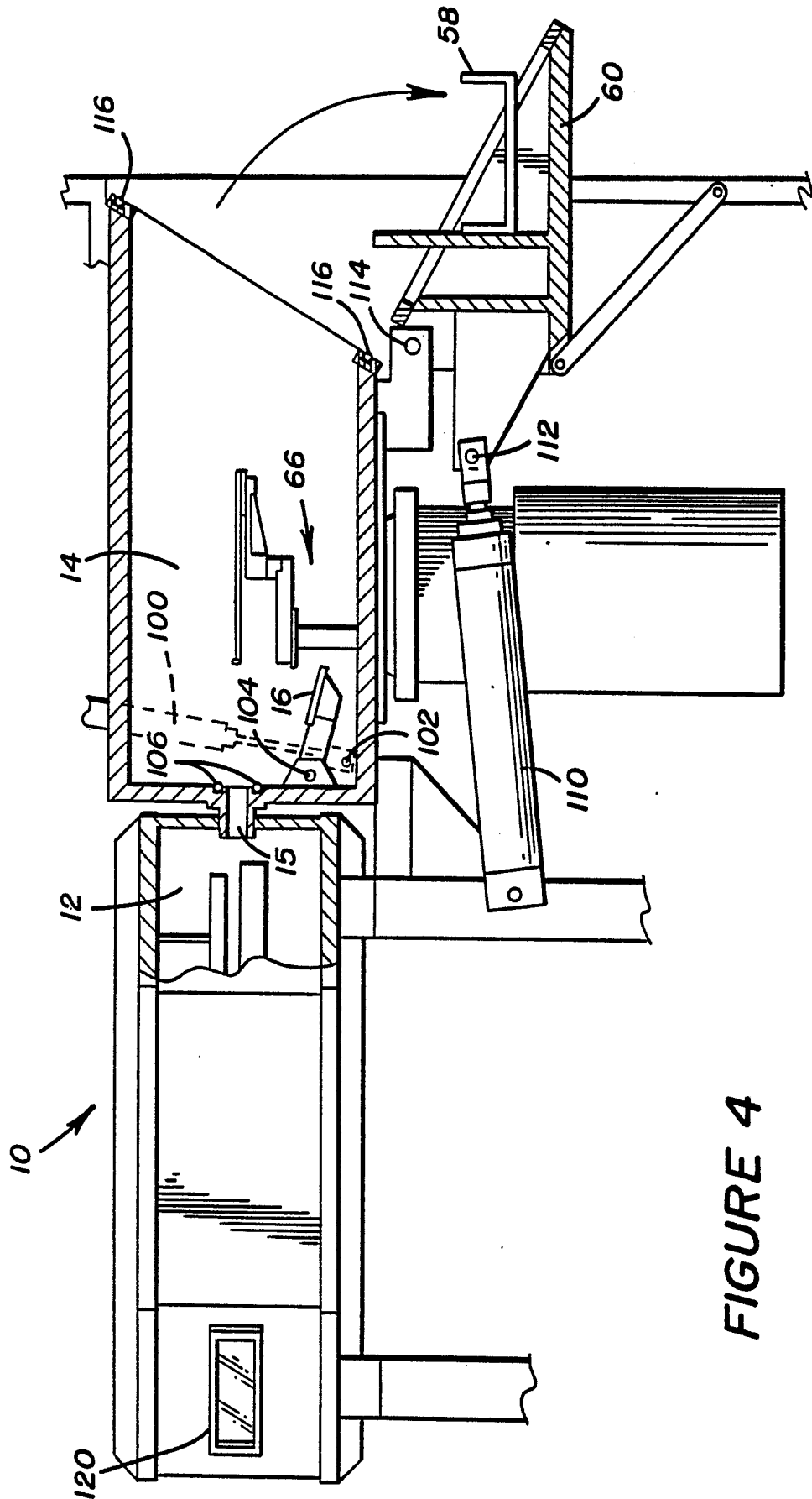
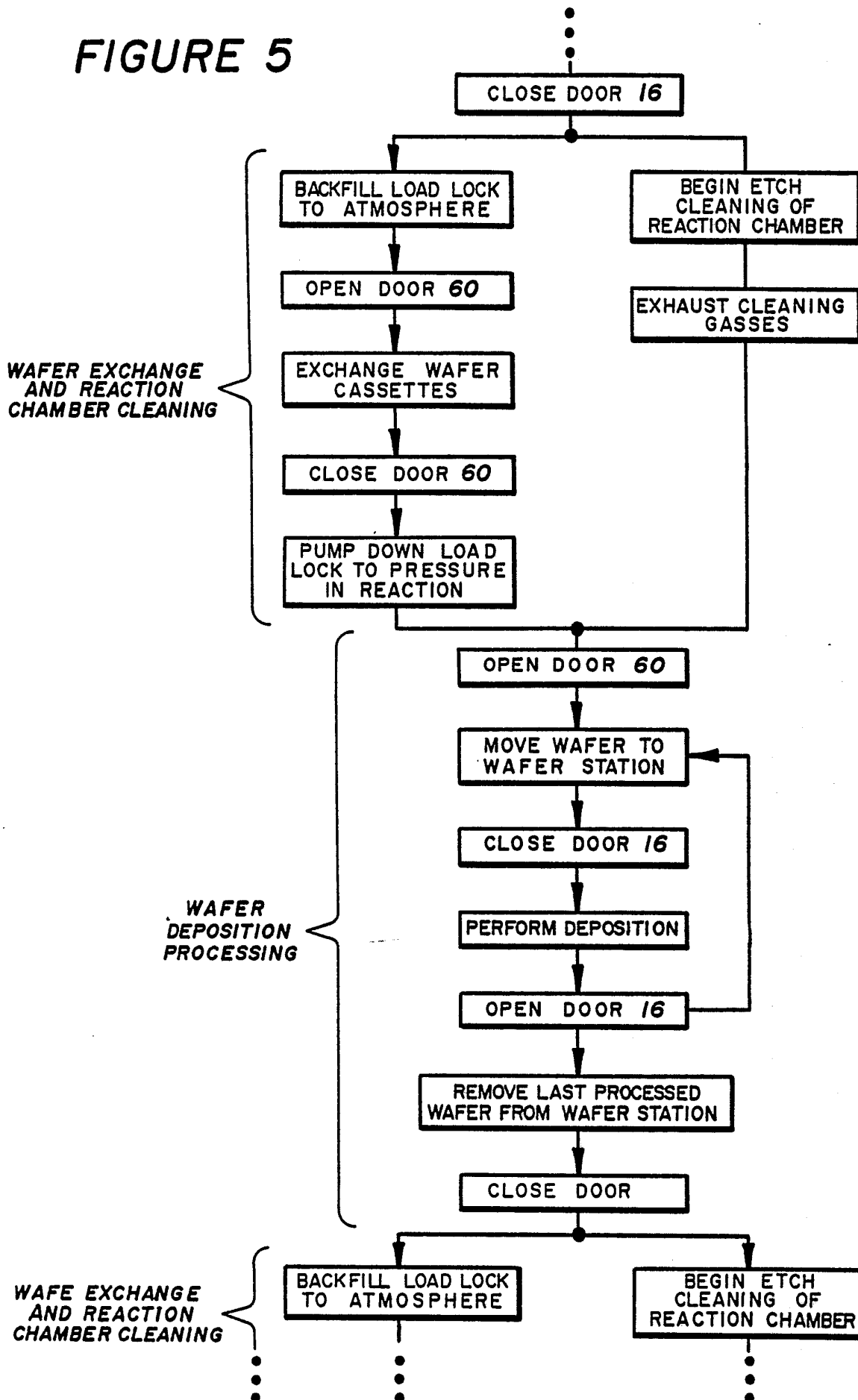

FIGURE 4

FIGURE 5



INTERNATIONAL SEARCH REPORT

International Application No PCT/US87/01176

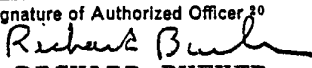
I. CLASSIFICATION OF SUBJECT MATTER (if several classification symbols apply, indicate all) ³		
According to International Patent Classification (IPC) or to both National Classification and IPC		
INT. CL. 4 C23C 16/00		
U.S. CL. 427/248.1, 118/715		
II. FIELDS SEARCHED		
Minimum Documentation Searched ⁴		
Classification System	Classification Symbols	
US	118/715, 723 156/345, 643	134/21, 22.1, 42 427/39, 248.1
Documentation Searched other than Minimum Documentation to the Extent that such Documents are Included in the Fields Searched ⁵		
III. DOCUMENTS CONSIDERED TO BE RELEVANT ¹⁴		
Category [*]	Citation of Document, ¹⁶ with indication, where appropriate, of the relevant passages ¹⁷	Relevant to Claim No. ¹⁸
Y	US, A, 4,138,306, PUBLISHED 06 FEBRUARY 1979, (NIWA)	1-5
Y	US, A, 4,293,249, PUBLISHED 06 OCTOBER 1981, (WHELAN)	1-5
Y	US, A, 4,576,698, PUBLISHED 18 MARCH 1986 (GALLAGHER ET AL)	1-5
<p>[*] Special categories of cited documents: ¹⁵</p> <p>"A" document defining the general state of the art which is not considered to be of particular relevance</p> <p>"E" earlier document but published on or after the international filing date</p> <p>"L" document which may throw doubts on priority claim(s) or which is cited to establish the publication date of another citation or other special reason (as specified)</p> <p>"O" document referring to an oral disclosure, use, exhibition or other means</p> <p>"P" document published prior to the international filing date but later than the priority date claimed</p> <p>"T" later document published after the international filing date or priority date and not in conflict with the application but cited to understand the principle or theory underlying the invention</p> <p>"X" document of particular relevance; the claimed invention cannot be considered novel or cannot be considered to involve an inventive step</p> <p>"Y" document of particular relevance; the claimed invention cannot be considered to involve an inventive step when the document is combined with one or more other such documents, such combination being obvious to a person skilled in the art.</p> <p>"&" document member of the same patent family</p>		
IV. CERTIFICATION		
Date of the Actual Completion of the International Search ²	Date of Mailing of this International Search Report ³	
25 JULY 1987	06 AUG 1987,	
International Searching Authority ¹	Signature of Authorized Officer ²⁰	
ISA/US	 RICHARD BUEKER	