

(No Model.)

2 Sheets—Sheet 1.

M. C. FULLENLOVE.
SAFETY APPLIANCE FOR ELEVATORS.

No. 524,979.

Patented Aug. 21, 1894.

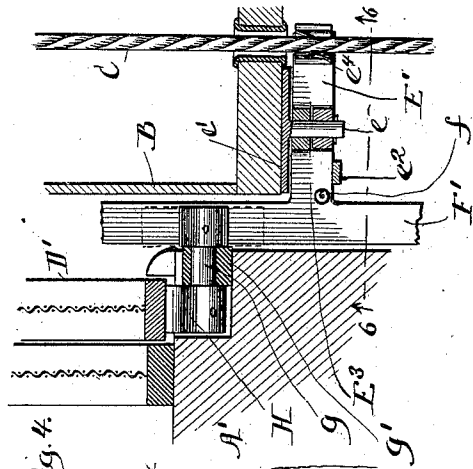

Fig. 4.

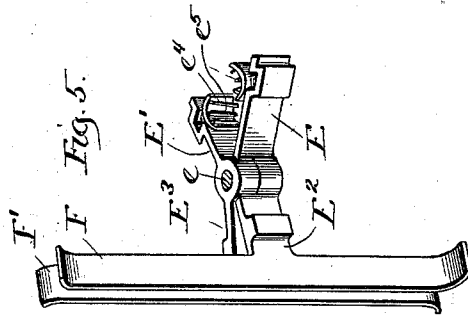

Fig. 5.

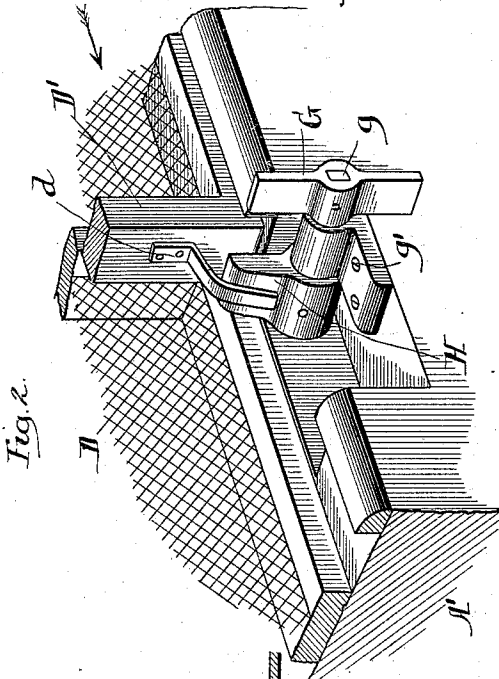

Fig. 2.

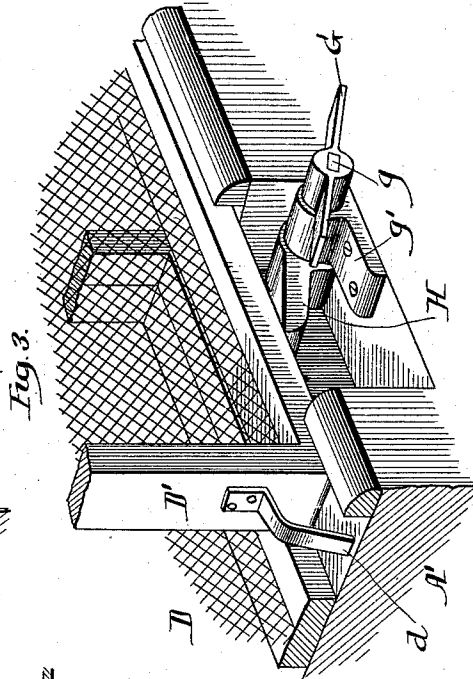

Fig. 3.

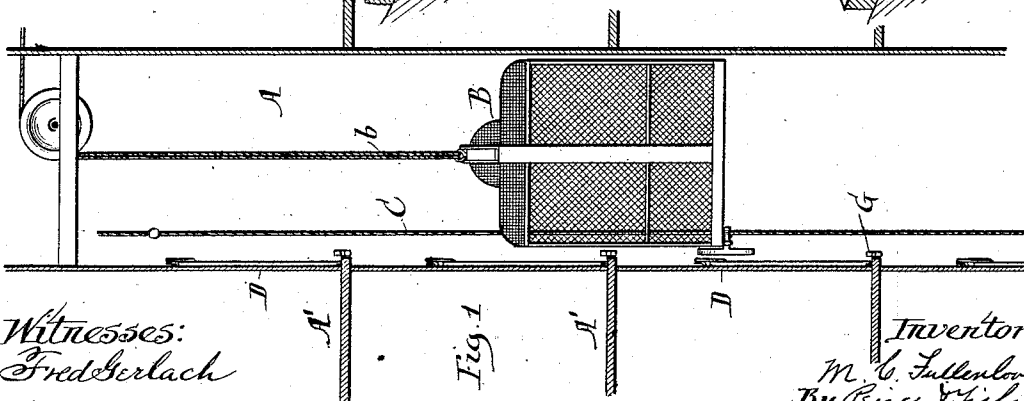

Fig. 1.

Witnesses:
Frederick
A. Adamick

Inventor:
M. C. Fullenlove
By Riva & Fisher
Attorneys.

(No Model.)

2 Sheets—Sheet 2.

M. C. FULLENLOVE.
SAFETY APPLIANCE FOR ELEVATORS.

No. 524,979.

Patented Aug. 21, 1894.

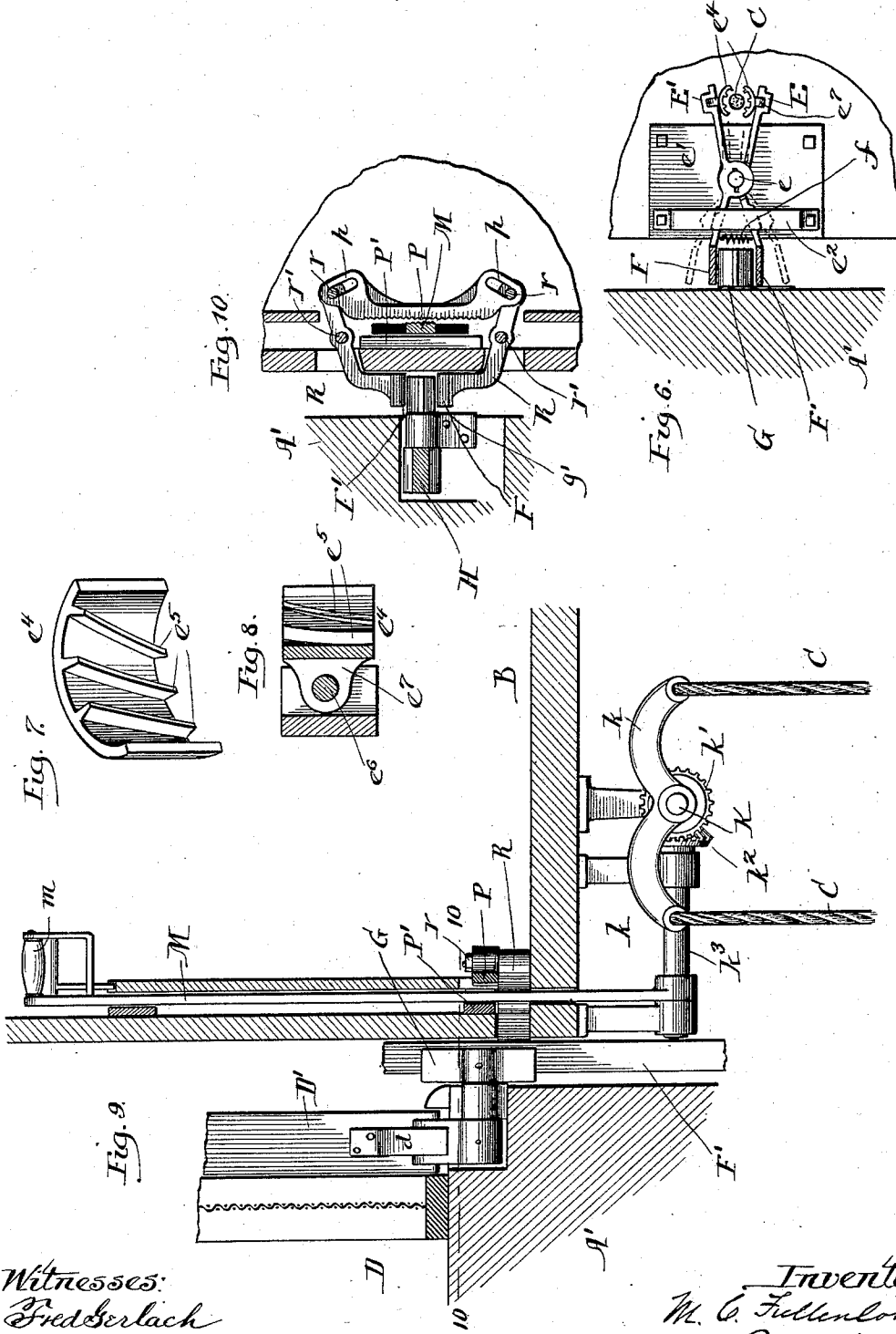

Witnesses:
Fred Berlach
A. Adamick.

Inventor:
M. C. Fullenlove
By Peirce & Fisher
Attorneys.

UNITED STATES PATENT OFFICE.

McCLELLAND C. FULLENLOVE, OF CHICAGO, ILLINOIS, ASSIGNOR OF ONE-HALF TO JOHN C. COSGROVE, OF SAME PLACE.

SAFETY APPLIANCE FOR ELEVATORS.

SPECIFICATION forming part of Letters Patent No. 524,979, dated August 21, 1894.

Application filed November 2, 1893. Serial No. 489,789. (No model.)

To all whom it may concern:

Be it known that I, McCLELLAND C. FULLENLOVE, a citizen of the United States, residing at Chicago, Cook county, Illinois, have invented certain new and useful Improvements in Safety Appliances for Elevators, of which I do declare the following to be a full, clear, and exact description, reference being had to the accompanying drawings, forming part of this specification.

In the running of elevators it often happens that the operator neglects to close the door or gate before the elevator car is started in upward or downward direction and as passengers attempt to get upon the elevator car while in motion there is danger of their being caught between the car and the floors past which the car is moving. This failure of the operator to close the doors or gates of the elevator shaft before starting the car is one of the most frequent causes of accidents in this class of apparatus, and the object of my present invention is to provide improved means whereby the movement of the elevator car either in upward or downward direction shall be checked until the door or gate opposite which the car has stopped, is closed. This object of invention I have accomplished by the novel mechanism hereinafter described, illustrated in the accompanying drawings and particularly defined in the several claims at the end of this specification.

Figure 1 is a view in vertical section through an elevator shaft, having my invention applied thereto. Fig. 2 is an enlarged perspective view looking from the shaft outward and showing the lower part of the elevator gate or door and part of the adjacent shaft inclosure, and showing also the means located adjacent the door for controlling the dogging mechanism that checks the moving of the elevator car when the door is open. Fig. 3 is a view similar to Fig. 2 but showing the door partially open. Fig. 4 is a view in vertical section through the bottom of the elevator car and the dogging mechanism affixed thereto and through the shifting mechanism located adjacent the door way for controlling said dogging mechanism. Fig. 5 is a detail perspective view of one form of dogging mechanism carried by the elevator car.

Fig. 6 is a view in horizontal section on line 6—6 of Fig. 4. Fig. 7 is a detail perspective view of one of the shoes with which the jaws of the dogging mechanism are furnished. Fig. 8 is a view in central vertical section through one of the jaws of the dogging mechanism shown in Figs. 1—6. Fig. 9 is a view in vertical section through an elevator and part of its shaft showing a modified form of my invention as applied to the controlling of the elevator cars, the starting and stopping of which is effected by a hand lever. Fig. 10 is a view in horizontal section on line 10—10 of Fig. 9.

In the form of my invention illustrated in Figs. 1—8 of the drawings my invention is shown as applied to that class of elevators in which the starting and stopping of the elevator is effected by means of an operator's cable that extends vertically through the car, and in Figs. 9 and 10 my invention is shown as applied to another familiar type of elevators in which the starting and stopping of the car is effected by a hand lever within convenient reach of the operator. It will be seen, however, that my invention is not restricted to the particular type of mechanism whereby the movement of the elevator car is effected.

A designates the shaft of the elevator that extends through the several floors A' of the building, and B denotes the elevator car that is raised and lowered by the usual cable *b*.

C designates the operator's cable that extends through the elevator car B and serves to effect the stopping and starting of the car in a manner well understood by those familiar with that class of apparatus.

The shaft of the elevator A is provided with the usual inclosure D, this inclosure being furnished at each floor with a door D' through which passengers may pass to and from the elevator car B; this door D' being sustained in a manner free to slide back and forth as well understood. Beneath the bottom of the elevator car B is mounted the dogging mechanism that serves to check the operator's cable C, or other means whereby the starting and stopping of the car is effected. In the form of this drawings this dogging mechanism com-

prises jaws E and E' pivoted together by a bolt *e* that depends from and is fixed to a plate *e'* attached to the bottom of the elevator car adjacent its edge, and from this plate *e'* depends a strap *e²* that extends beneath the dogging mechanism and serves to hold the same against displacement. The jaws E and E' are provided with arms E² and E³, the outer ends of which carry the vertical plates or extensions F and F' that extend at the side of the elevator for some distance above and below its floor. A spring *f* may be used to hold jaws E and E' normally apart. The dogging mechanism is located upon the bottom of the elevator car at such point that its jaws will serve as a clutch to engage the operator's cable C and preferably the jaws of the dogging mechanism are each provided with the shoes *e⁴* having curved ribs *e⁵* to enter the spaces between the strands of the cable in order to more firmly hold the cable. Preferably also the shoes *e⁴* are pivotally connected to the jaws by a bolt *e⁶* that passes through an extension *e⁷* formed on the back of each of the shoes *e⁴*. The purpose of thus providing the jaws of the dogging mechanism with pivoted shoes is to enable this mechanism to more certainly hold the cable and it is obvious that if the jaws be caused to bear against the cable C and the operator within the car attempts to move the cable in either direction, the shoes *e⁴* turning upon their pivot point will tend to more firmly bind and hold the cable.

Upon each of the floors A', or at other adjacent points of the elevator shaft is mounted the shifting mechanism whereby the dogging mechanism will be brought into operation to check the operator's cable when the door or gate of the elevator car is in open position. This shifting mechanism, or shifter, in the preferred form of my invention consists of an arm or plate G that is mounted upon a short shaft *g* journaled within a fixed bracket *g'*, the opposite end of the shaft *g* being provided with an arm or extension H adapted to be operated by the door D' of the elevator car. The door D' is preferably furnished with an arm or plate *d* that serves to engage the arm H and restore it to position when the door is closed. The shifter is so located that when the door D' is in closed position the arm or plate G will not affect the movement of the plates or extensions F and F' of the dogging mechanism, as these plates have curved ends and are at such distances apart as to freely pass the arm or plate G when the latter is in the vertical position shown in Fig. 2 of the drawings. It will be seen, however, that when the car B is brought opposite a floor A' of the shaft the arm or plate G will at such time be between the plates or extensions F and F' of the dogging mechanism, and if now the door D' be opened by moving it in the direction of the arrow Fig. 2, the bottom of the door will contact with and rock backward the arm H of the shifter, thereby turning the shifter to the position shown in

Fig. 3 of the drawings. When the shifter is thus turned to the position shown in Fig. 3, the arm or plate G will spread apart the plates or extensions F and F' of the dogging mechanism and will thereby cause the jaws E and E' of this mechanism to firmly grip the operator's cable C, and it is manifest that so long as the door D' remains open the operator's cable will be thus held against movement, and it will be impossible for the operator to start the elevator car. When, however, the door D' is closed, the arm or plate *d* at the bottom of the door (see Figs. 2 and 3), will contact with the arm H and restore the shifter to the position seen in Fig. 1, thereby releasing the plates or extensions F and F' of the dogging mechanism and thus relieve the operator's cable C from the jaws E and E'.

It is manifest that the details of construction above set out may be varied within wide limits without departing from the spirit of my invention and that my invention may be applied to the various types of apparatus commonly employed for effecting the starting and stopping of the elevator cars. Thus for example, in Figs. 9 and 10 of the drawings I have shown a modification of my invention adapted for use in connection with that type of elevators in which a hand lever is employed for effecting the starting and stopping of the elevator car. In this type of elevators, it is customary to mount beneath the floor of the car B, a rock shaft K carrying arms *k* to the ends of which are attached sections of the operator's cable C.

The rock shaft K is furnished with a bevel pinion *k¹* with which engages a like pinion *k²* mounted upon a shaft *k³* conveniently journaled beneath the floor of the elevator car. To the shaft *k³* is attached a hand lever M, the grip-handle *m* of which extends to a point within convenient reach of the operator as well understood. In order to arrest the movement of the hand lever M so long as the door of the elevator car is open, I mount upon the elevator a dogging mechanism comprising a movable jaw P, the ends of which are provided with the angular slots *p* within which enter the studs *r* of the arms R that are pivoted as at *r'*. The opposite end of these pivoted arms R extend outside the elevator car and are furnished with the plates or extensions F and F' similar to the plates or extensions hereinbefore described, and arranged to be operated by a shifter such as that hereinbefore described. This shifter consists of a plate or bar G fixed to one end of the shaft *g*, the opposite end of this shaft being provided with an arm H extending into position to be operated by the door D' of the elevator, a plate or bar *d* serving to restore the arm H to normal position when the door D' is closed. In order to enable the jaw P to more effectively check the movement of the hand lever M, I prefer to form the face of this jaw with serrations, and to provide similar serrations

or teeth upon that part of the hand lever against which the jaw P will bear. And between the hand lever M and the vertical wall of the elevator car, I prefer to place a bearing plate P' at a point opposite the jaw P in order to resist the thrust of the jaw as it bears against the hand lever.

From the foregoing description it will be seen that when the elevator car B has been brought opposite the door-way and the door D' thereof has been opened, the shifter, being at such time between the plates F and F' will spread these plates thereby causing the arms R to rock about their pivot points so as to move the pins *r* of these arms toward each other. This movement of the pins *r* along the incline slots *p* of the jaw P will force inward this jaw, causing its serrated face to bear against the hand lever M thereby locking the lever against movement until the door of the elevator has been closed and the shifter has been restored to its normal position.

It will thus be seen that by means of my invention the elevator car must remain at rest until the door opposite which it has been stopped is in closed position, and consequently all danger of injury to passengers by getting on and off the elevator car while it is in motion is avoided. I do not wish my invention to be understood as restricted to the details of construction above set out since these may be varied within wide limits without departing from the spirit of the invention.

Having thus described the invention, what I claim as new, and desire to secure by Letters Patent, is—

1. The combination with an elevator shaft, a gate for closing a door-way of said shaft, an elevator car and mechanism for starting and stopping said car, of a clutch carried by the car for checking said starting and stopping mechanism, pivoted arms arranged outside the car for operating said clutch, and a shifter fixed in the hatchway and extending into position to engage said arms and having a part extending into position to be engaged by said gate.

2. The combination with an elevator shaft, a gate for closing a door-way of said shaft, an elevator car and mechanism for starting and stopping said car, of dogging mechanism for checking said starting and stopping mechanism comprising a clutch having at least one movable jaw, pivotally sustained plates arranged outside the car but carried thereby for operating said jaw, a shifter for engaging said plates, said shifter being fixed in the hatchway and having an arm extending into position to be operated by the gate.

3. The combination with an elevator shaft, a gate for closing a door-way of said shaft, an

elevator car and mechanism for starting and stopping said car, of dogging mechanism for checking said starting and stopping mechanism comprising a clutch carried by the car for engaging said starting and stopping mechanism, pivotally sustained elongated plates F and F' connected with said clutch and a shifter fixed in the hatchway and having a pivoted arm or plate F arranged in position to engage said pivotally sustained plates F and F', and having an arm H arranged to be operated by the door.

4. The combination with an elevator shaft, a gate for closing a door-way of said shaft, an elevator car and mechanism for starting and stopping said car, of dogging mechanism for checking said starting and stopping mechanism comprising a clutch carried by the car and a shifter for operating said clutch comprising a pivoted arm G, fixed in the hatchway, an arm or extension H arranged in position to be operated by the door and an extension or plate *d* connected to the door for engaging said arm H.

5. The combination with an elevator shaft, a gate for closing a door-way of said shaft, an elevator car and mechanism for starting and stopping said car, of dogging mechanism for checking said starting and stopping mechanism comprising a clutch, pivoted arms for operating said clutch, said arms being provided with vertical plates F and F' and a shifter for bringing said clutch into operation, comprising a pivoted arm G fixed in the elevator shaft and between the paths of travel of the plates F and F', and an arm or extension H connected to said arm G and arranged in position to be engaged by said gate.

6. The combination with an elevator shaft, a gate for closing a door-way of said shaft, an elevator car and mechanism for starting and stopping said car, of dogging mechanism for checking said starting and stopping mechanism comprising pivoted jaws having ribs arranged to enter between the strands of the cable, and a suitable shifter for engaging said dogging mechanism, said shifter being located in position to be operated by the door.

7. The combination with an elevator shaft, a gate for closing a door-way of said shaft, an elevator car and mechanism for starting and stopping said car, of dogging mechanism for checking said starting and stopping mechanism comprising a clutch having pivoted jaws provided with shoes pivotally mounted therein, and a shifter for operating said jaws, said shifter being arranged in position to be operated by said gate.

MCCLELLAND C. FULLENLOVE.

Witnesses:

FRED GERLACK,
GEO. P. FISHER, Jr.