



US011088026B2

(12) **United States Patent**  
**Cheng et al.**

(10) **Patent No.:** **US 11,088,026 B2**

(45) **Date of Patent:** **Aug. 10, 2021**

(54) **WIMPY DEVICE BY SELECTIVE LASER ANNEALING**

(71) Applicant: **INTERNATIONAL BUSINESS MACHINES CORPORATION**, Armonk, NY (US)

(72) Inventors: **Kangguo Cheng**, Schenectady, NY (US); **Nicolas J. Loubet**, Guilderland, NY (US); **Xin Miao**, Slingerlands, NY (US); **Alexander Reznicek**, Troy, NY (US)

(73) Assignee: **ELPIS TECHNOLOGIES INC.**, Ottawa (CA)

(\*) Notice: Subject to any disclaimer, the term of this patent is extended or adjusted under 35 U.S.C. 154(b) by 1 day.

(21) Appl. No.: **16/717,564**

(22) Filed: **Dec. 17, 2019**

(65) **Prior Publication Data**

US 2020/0126862 A1 Apr. 23, 2020

**Related U.S. Application Data**

(60) Continuation of application No. 15/941,794, filed on Mar. 30, 2018, now Pat. No. 10,566,240, which is a (Continued)

(51) **Int. Cl.**  
**H01L 21/8234** (2006.01)  
**H01L 21/84** (2006.01)

(Continued)

(52) **U.S. Cl.**  
CPC .... **H01L 21/823418** (2013.01); **H01L 21/268** (2013.01); **H01L 21/324** (2013.01); (Continued)

(58) **Field of Classification Search**

CPC ..... H01L 29/1054; H01L 27/092; H01L 21/823814; H01L 21/823807; H01L 21/823431; H01L 21/823821; H01L 21/845; H01L 29/66795-66818; H01L 29/41791; H01L 29/785-786;

(Continued)

(56) **References Cited**

U.S. PATENT DOCUMENTS

8,099,686 B2 1/2012 Schultz  
8,324,668 B2 12/2012 Huang et al.  
(Continued)

FOREIGN PATENT DOCUMENTS

TW 201537751 A 10/2015

OTHER PUBLICATIONS

List of IBM Patents or Patent Applications Treated as Related dated Dec. 17, 2019, 2 pages.

(Continued)

*Primary Examiner* — Sonya McCall-Shepard

(74) *Attorney, Agent, or Firm* — Tutunjian & Bitetto, P.C.

(57) **ABSTRACT**

A device having co-integrated wimpy and nominal transistors includes first source/drain regions formed with a semiconductor alloy imparting strain into a first channel region. The device also has wimpy transistors including second source/drain regions formed with the semiconductor alloy that has been decomposed to include a larger amount of an electrically active atomic element than contained in the semiconductor alloy of the first source/drain region.

**19 Claims, 6 Drawing Sheets**

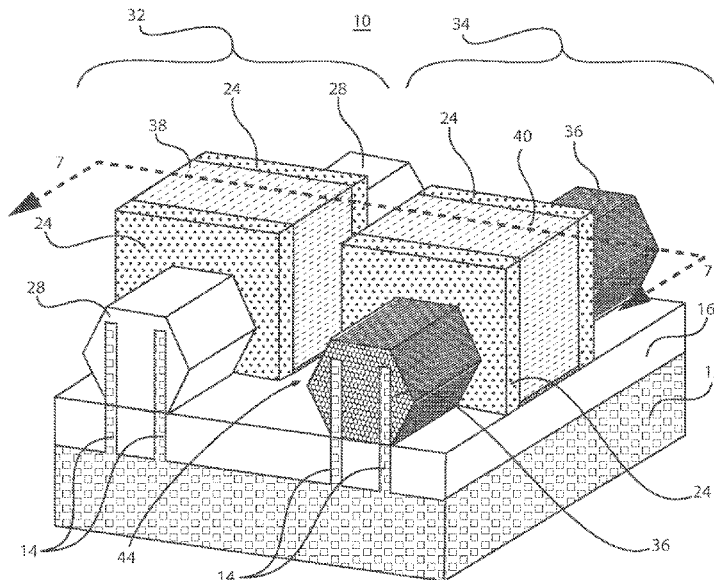

**Related U.S. Application Data**

continuation of application No. 15/615,331, filed on Jun. 6, 2017, now Pat. No. 9,991,166, which is a division of application No. 15/241,858, filed on Aug. 19, 2016, now Pat. No. 9,911,656.

(51) **Int. Cl.**

**H01L 21/268** (2006.01)  
**H01L 21/324** (2006.01)  
**H01L 29/78** (2006.01)  
**H01L 29/08** (2006.01)  
**H01L 29/24** (2006.01)  
**H01L 29/267** (2006.01)  
**H01L 29/66** (2006.01)  
**H01L 27/088** (2006.01)

(52) **U.S. Cl.**

CPC .... **H01L 21/823431** (2013.01); **H01L 21/845** (2013.01); **H01L 27/0886** (2013.01); **H01L 29/0847** (2013.01); **H01L 29/24** (2013.01); **H01L 29/267** (2013.01); **H01L 29/66545** (2013.01); **H01L 29/7848** (2013.01); **H01L 27/088** (2013.01)

(58) **Field of Classification Search**

CPC ..... H01L 2029/7857-7858; H01L 27/0886;

H01L 27/0924; H01L 27/10826; H01L 27/10879; H01L 27/1211

See application file for complete search history.

(56)

**References Cited**

U.S. PATENT DOCUMENTS

8,476,716	B2	7/2013	Anderson et al.	
9,257,505	B2	2/2016	Lai et al.	
9,337,193	B2	5/2016	Liao et al.	
9,337,306	B2	5/2016	Peng et al.	
9,842,929	B1 *	12/2017	Cheng .....	H01L 27/0924
2007/0155063	A1	7/2007	Datta et al.	
2011/0147765	A1	6/2011	Huang et al.	
2012/0091531	A1	4/2012	Baldwin et al.	
2012/0211838	A1 *	8/2012	Kronholz .....	H01L 21/823814 257/369
2015/0235897	A1	8/2015	Fu et al.	
2015/0325646	A1	11/2015	Lai et al.	

OTHER PUBLICATIONS

U.S. Office Action issued in U.S. Appl. No. 15/705,856, dated Apr. 4, 2018, 13 pages.  
 Disclosed Anonymously, "Selective Strain Relaxation of Fins in FinFET Structures by Implantation and Recrystallization" ip.com No. IPCOM000242695D (Aug. 4, 2015) pp. 1-4.

\* cited by examiner

10

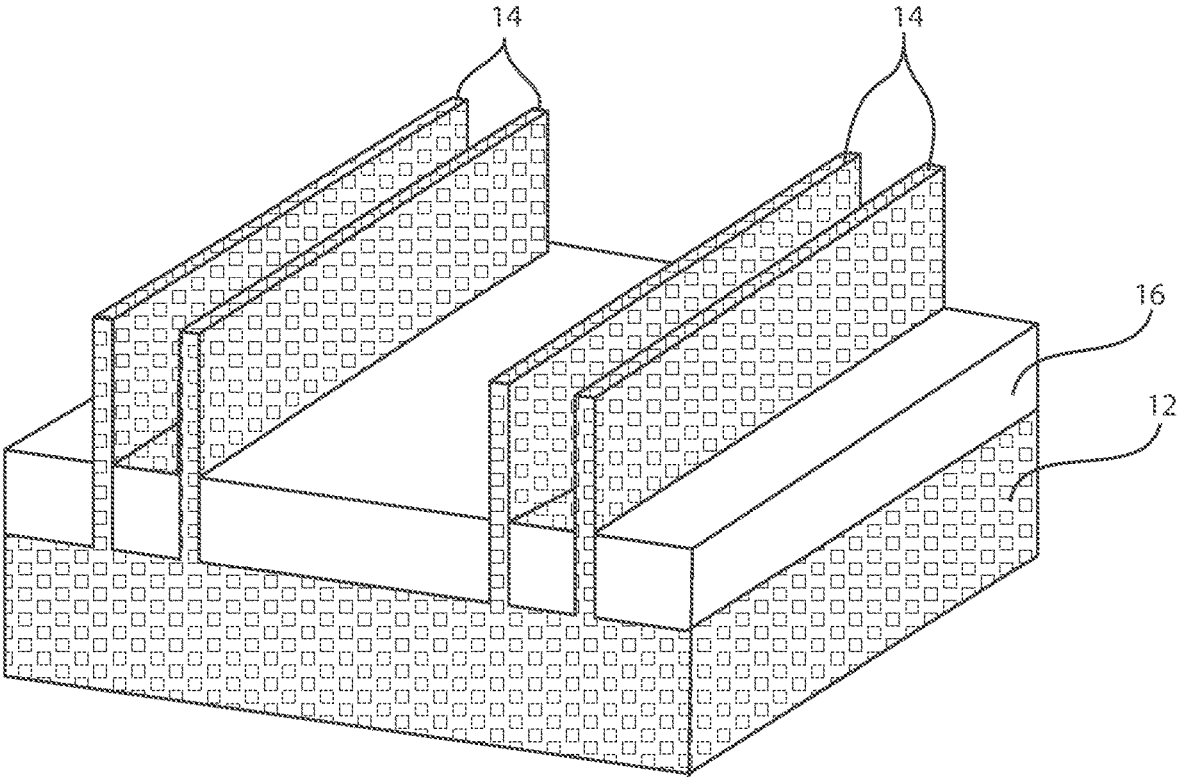

FIG. 1

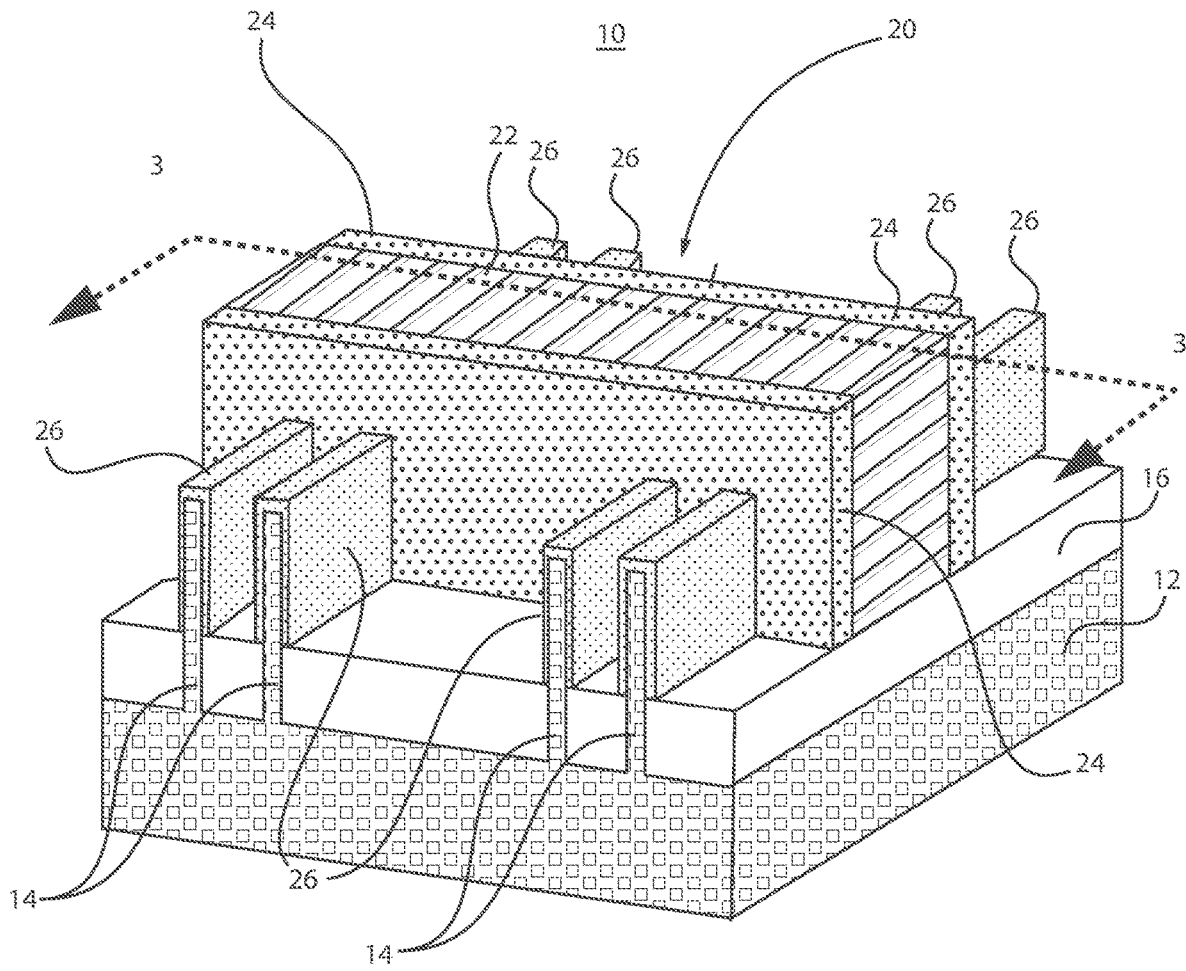

FIG. 2

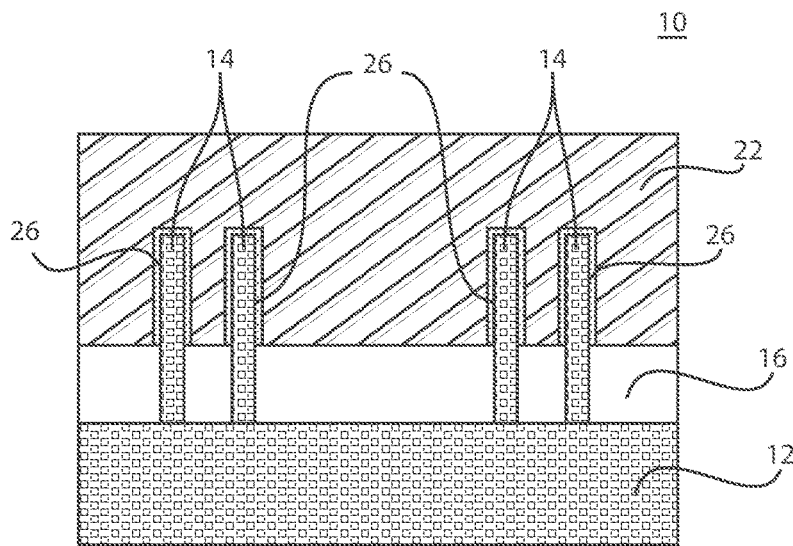

FIG. 3

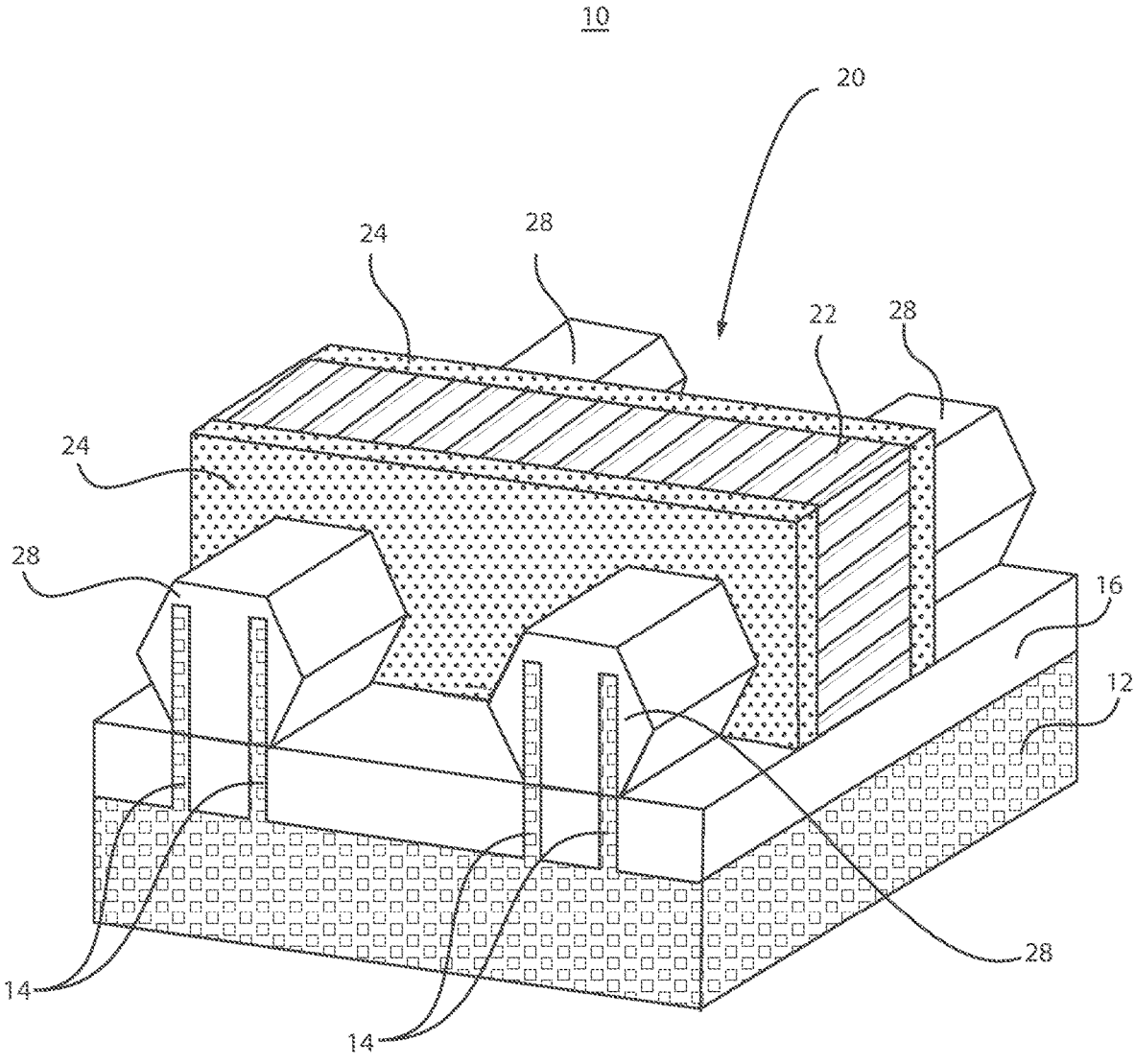

FIG. 4





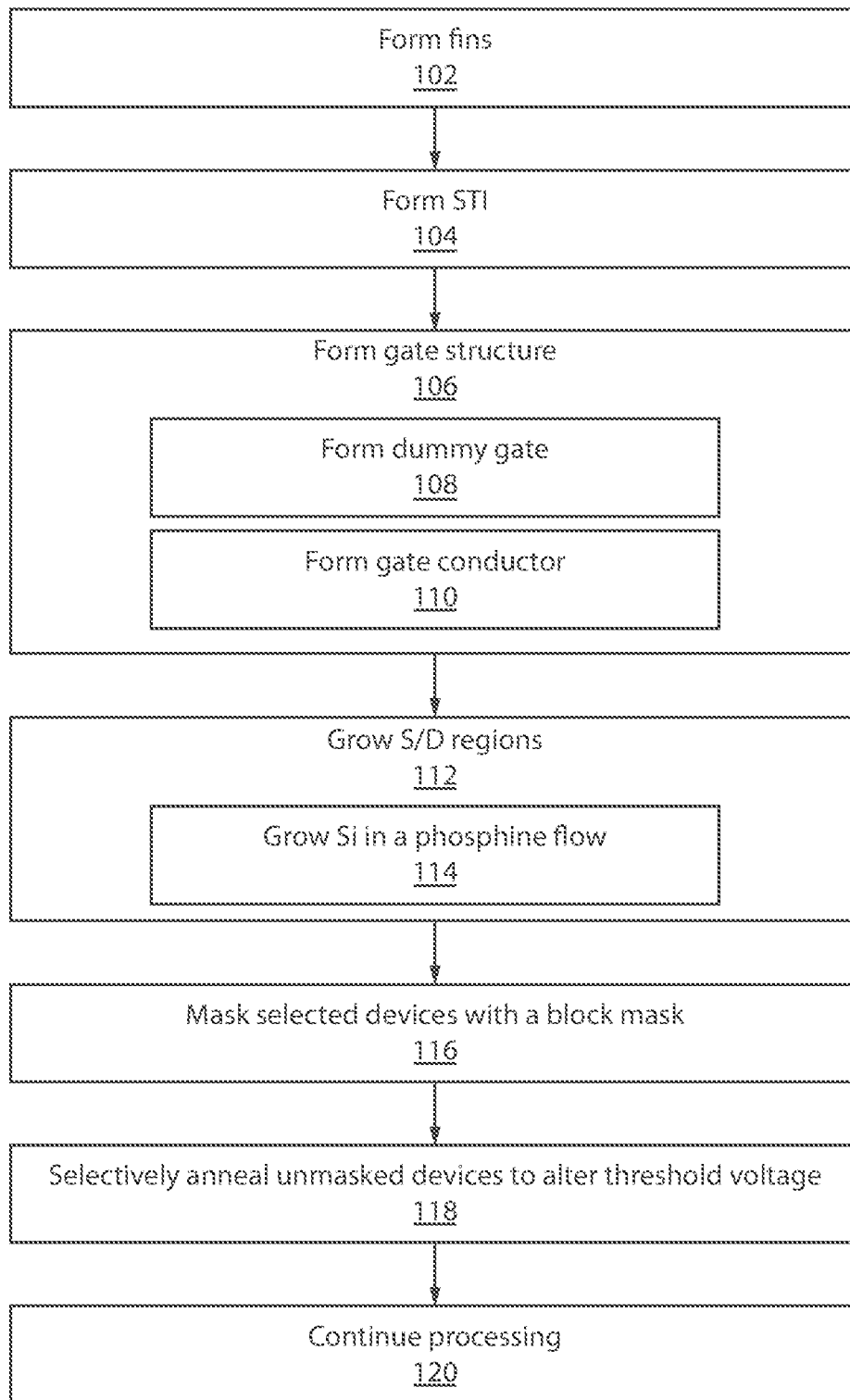

FIG. 8

1

## WIMPY DEVICE BY SELECTIVE LASER ANNEALING

### BACKGROUND

#### Technical Field

The present invention generally relates to semiconductor processing, and more particularly to methods and devices having a combination of wimpy and nominal devices integrated together by employing a selective anneal, e.g., laser annealing.

#### Description of the Related Art

Devices in non-critical circuit paths are preferred to have larger threshold voltages ( $V_t$ ) than nominal devices. This assists in maintaining low leakage rates while not compromising circuit performance. These devices with larger  $V_t$  are called 'wimpy' devices. Conventionally, wimpy devices are made with larger gate lengths ( $L_g$ ) and have higher channel doping than the nominal devices. These features employ special device and mask designs and require additional steps of lithography and implantation.

As devices scale down, making wimpy devices with larger  $L_g$  and a same contacted gate (poly) pitch (CPP) as for the nominal devices is impractical because there is very little room for contacts, among other things.

#### SUMMARY

In accordance with an embodiment of the present principles, a device having co-integrated wimpy and nominal transistors includes first source/drain regions formed with a semiconductor alloy imparting strain into a first channel region. The device also has wimpy transistors including second source/drain regions formed with the semiconductor alloy that has been decomposed to include a larger amount of an electrically active atomic element than contained in the semiconductor alloy of the first source/drain region.

In accordance with another embodiment, a device having co-integrated wimpy and nominal transistor includes first fins and second fins formed on a substrate as well as first source/drain regions formed on the first fins adjacent to a first gate structure to form nominal device structures with a first material. The device also includes second source/drain regions formed on the second fins adjacent to a second gate structure to form wimpy device structures with a second material formed of decomposed first material. The wimpy device structures of the device have a different concentration of an electrically conductive atomic element than the nominal device structures such that the wimpy device structures have different threshold voltages than the nominal device structures. These and other features and advantages will become apparent from the following detailed description of illustrative embodiments thereof, which is to be read in connection with the accompanying drawings.

#### BRIEF DESCRIPTION OF THE SEVERAL VIEWS OF THE DRAWINGS

The disclosure will provide details in the following description of preferred embodiments with reference to the following figures wherein:

FIG. 1 is a perspective view showing fins formed on/in a substrate in accordance with the present principles;

2

FIG. 2 is a perspective view showing a gate structure formed on the fins of FIG. 1 in accordance with the present principles;

FIG. 3 is a cross-sectional view taken at section line 3-3 of FIG. 2 in accordance with the present principles;

FIG. 4 is a perspective view showing source/drain regions formed over the fins of FIG. 2 in accordance with the present principles;

FIG. 5 is a perspective view showing a block mask formed over a portion of the source/drain regions of FIG. 4 and unmasked regions exposed to a selective anneal process (e.g., laser anneal) in accordance with the present principles;

FIG. 6 is a perspective view showing nominal devices and wimpy devices co-integrated on a same device in accordance with the present principles;

FIG. 7 is a cross-sectional view taken at section line 7-7 of FIG. 6 in accordance with the present principles; and

FIG. 8 is a block/flow diagram showing methods for co-integrating wimpy and nominal devices in accordance with the present principles.

#### DETAILED DESCRIPTION

In accordance with the present principles, devices and methods are provided for forming wimpy devices with a same gate length ( $L_g$ ), contacted gate (poly) pitch (CPP), and a same channel doping as nominal devices to save design and processing costs. In accordance with useful embodiments, wimpy and nominal devices are formed concurrently and include similar structure and materials.

In one particularly useful embodiment, source/drain epitaxial growth is performed in a phosphine environment.  $Si_3P_4$  is formed when an overabundance of phosphine flows into a process gas during a fast growing low temperature epitaxial silicon process. The  $Si_3P_4$  compound gets incorporated into the silicon lattice and creates a tensile strain (as compared with the underlying silicon substrate lattice, e.g., on a planar substrate or a fin). The phosphorus is chemically bonded and not electrically active (e.g., an overall phosphorus concentration may be about  $4 \times 10^{21}$  atoms, but only  $2 \times 10^{20}$ - $3 \times 10^{20}$  phosphorus atoms are electrically active. Electrical active phosphorus is not bound in the  $Si_3P_4$ ).

$Si_3P_4$  is very thermally stable. However, in accordance with one embodiment, laser selective annealing (LSA) may be employed to heat the epitaxially grown material at or above 1200 degrees C., which relaxes the strain, but also increases the active phosphorus amount by decomposition of the  $Si_3P_4$  compound. Resistance of relaxed  $Si_3P_4$  is nearly the same as strained  $Si_3P_4$ . In this way, the threshold voltage of some devices may be altered in accordance with the LSA while maintaining a common processing of the semiconductor devices (e.g., wimpy and nominal devices).

It is to be understood that the present invention will be described in terms of a given illustrative architecture; however, other architectures, structures, substrate materials and process features and steps may be varied within the scope of the present invention.

It will also be understood that when an element such as a layer, region or substrate is referred to as being "on" or "over" another element, it can be directly on the other element or intervening elements may also be present. In contrast, when an element is referred to as being "directly on" or "directly over" another element, there are no intervening elements present. It will also be understood that when an element is referred to as being "connected" or "coupled" to another element, it can be directly connected or coupled to the other element or intervening elements may be

present. In contrast, when an element is referred to as being “directly connected” or “directly coupled” to another element, there are no intervening elements present.

The present embodiments may include a design for an integrated circuit chip, which may be created in a graphical computer programming language, and stored in a computer storage medium (such as a disk, tape, physical hard drive, or virtual hard drive such as in a storage access network). If the designer does not fabricate chips or the photolithographic masks used to fabricate chips, the designer may transmit the resulting design by physical means (e.g., by providing a copy of the storage medium storing the design) or electronically (e.g., through the Internet) to such entities, directly or indirectly. The stored design is then converted into the appropriate format (e.g., GDSII) for the fabrication of photolithographic masks, which typically include multiple copies of the chip design in question that are to be formed on a wafer. The photolithographic masks are utilized to define areas of the wafer (and/or the layers thereon) to be etched or otherwise processed.

Methods as described herein may be used in the fabrication of integrated circuit chips. The resulting integrated circuit chips can be distributed by the fabricator in raw wafer form (that is, as a single wafer that has multiple unpackaged chips), as a bare die, or in a packaged form. In the latter case, the chip is mounted in a single chip package (such as a plastic carrier, with leads that are affixed to a motherboard or other higher level carrier) or in a multichip package (such as a ceramic carrier that has either or both surface interconnections or buried interconnections). In any case, the chip is then integrated with other chips, discrete circuit elements, and/or other signal processing devices as part of either (a) an intermediate product, such as a motherboard, or (b) an end product. The end product can be any product that includes integrated circuit chips, ranging from toys and other low-end applications to advanced computer products having a display, a keyboard or other input device, and a central processor.

It should also be understood that material compounds will be described in terms of listed elements, e.g., SiGe. These compounds include different proportions of the elements within the compound, e.g., SiGe includes  $\text{Si}_x\text{Ge}_{1-x}$  where  $x$  is less than or equal to 1, etc. In addition, other elements may be included in the compound and still function in accordance with the present principles. The compounds with additional elements will be referred to herein as alloys.

Reference in the specification to “one embodiment” or “an embodiment” of the present principles, as well as other variations thereof, means that a particular feature, structure, characteristic, and so forth described in connection with the embodiment is included in at least one embodiment of the present principles. Thus, the appearances of the phrase “in one embodiment” or “in an embodiment”, as well as other variations, appearing in various places throughout the specification are not necessarily all referring to the same embodiment.

It is to be appreciated that the use of any of the following “/”, “and/or”, and “at least one of”, for example, in the cases of “A/B”, “A and/or B” and “at least one of A and B”, is intended to encompass the selection of the first listed option (A) only, or the selection of the second listed option (B) only, or the selection of both options (A and B). As a further example, in the cases of “A, B, and/or C” and “at least one of A, B, and C”, such phrasing is intended to encompass the selection of the first listed option (A) only, or the selection of the second listed option (B) only, or the selection of the third listed option (C) only, or the selection of the first and

the second listed options (A and B) only, or the selection of the first and third listed options (A and C) only, or the selection of the second and third listed options (B and C) only, or the selection of all three options (A and B and C). This may be extended, as readily apparent by one of ordinary skill in this and related arts, for as many items listed.

The terminology used herein is for the purpose of describing particular embodiments only and is not intended to be limiting of example embodiments. As used herein, the singular forms “a,” “an” and “the” are intended to include the plural forms as well, unless the context clearly indicates otherwise. It will be further understood that the terms “comprises,” “comprising,” “includes” and/or “including,” when used herein, specify the presence of stated features, integers, steps, operations, elements and/or components, but do not preclude the presence or addition of one or more other features, integers, steps operations, components and/or groups thereof.

Spatially relative terms, such as “beneath,” “below,” “lower,” “above,” “upper,” and the like, may be used herein for ease of description to describe one element’s or feature’s relationship to another element(s) or feature(s) as illustrated in the FIGS. It will be understood that the spatially relative terms are intended to encompass different orientations of the device use or operation in addition to the orientation depicted in the FIGS. For example, if the device in the FIGS. is turned over elements described as “below” or “beneath” other elements or features would then be oriented “above” the other elements or features. Thus, the term “below” can encompass both an orientation of above and below. The device may be otherwise oriented (rotated 90 degrees or at other orientations), and the spatially relative descriptors used herein may be interpreted accordingly. In addition, it will also be understood that when a layer is referred to as being “between” two layers, it can be the only layer between the two layers, or one or more intervening layers may also be present.

It will be understood that, although the terms first, second, etc. may be used herein to describe various elements, these elements should not be limited by these terms. These terms are only used to distinguish one element from another element. Thus, a first element discussed below could be termed a second element without departing from the scope of the present concept.

Referring now to the drawings in which like numerals represent the same or similar elements and initially to FIG. 1, a partially fabricated semiconductor device **10** is shown having fins **14** formed from a substrate **12**. The substrate **12** may include a bulk-semiconductor substrate. In one example, the bulk-semiconductor substrate **12** may be a silicon-based material. Illustrative examples of Si-based materials suitable for the bulk-semiconductor substrate **12** include, but are not limited to, Si, SiGe, SiGeC, SiC, etc. and multi-layers thereof. Although silicon is the predominantly used semiconductor material in wafer fabrication, alternative semiconductor materials can be employed, such as, but not limited to, germanium, gallium arsenide, gallium nitride, silicon germanium, cadmium telluride, zinc selenide, etc. Although not depicted in FIG. 1, the semiconductor substrate **12** may also be a semiconductor on insulator (SOI) substrate.

Fins **14** may be etched into the substrate **12** by employing a lithographic patterning process, a spacer image transfer process (e.g., self-aligned quadruple patterning (SAQP) or a self-aligned double patterning (SADP)), etc. to form an etch

mask and then etch the substrate **12** using, e.g., a reactive ion etch (RIE) process. The fins **14** are etched to a desired depth.

A dielectric layer **16** is deposited over the fins and recessed by a recess etch process to form a shallow trench isolation region **16**. The dielectric layer **16** may include an oxide, although other suitable dielectric materials may be employed. The dielectric layer **16** may be formed by a blanket deposition process using, e.g., chemical vapor deposition (CVD) or other suitable processes. In an alternate embodiment, the blanket deposition of dielectric layer **16** is followed by a planarization process (e.g., chemical mechanical polishing (CMP)). Then, a fin cut process may be employed where the fin lengths are adjusted. This may include a lithographic patterning and etch. A reveal etch (selectively etched relative to the substrate/fin material) is performed to expose the fins **14** to provide the configuration depicted in FIG. 1.

Referring to FIG. 2, an extended gate (EG) oxide **26** is formed over the fins **14**. The oxide **26** may be formed by an oxidation process or by atomic layer deposition (ALD). The oxidation process forms the oxide **26** over exposed portions of the fins **14**. Then, a gate formation process is performed to provide a gate structure **20**.

The gate formation process may include a gate first process or a replacement gate or gate last process. In a gate first process, gate materials are formed and patterned that will be employed as the actual gate. In a gate last process, a dummy gate is formed and then later removed and replaced by permanent gate materials.

A gate material **22** is deposited and patterned using lithography, SADP, etc. and etching (e.g., RIE). A hardmask (not shown) may be deposited on the gate materials **22** and patterned along with the gate materials **22**. The hardmask may include a suitable dielectric material, such as, e.g., silicon nitride or silicon oxynitride.

The gate materials **22** may include polysilicon or amorphous silicon if a dummy gate is employed for a gate last/replacement gate structure. The gate material **22** is patterned over the fins **14**, and a spacer **24** is formed on sidewalls of the gate material **22**.

A conformal spacer layer is deposited over all surfaces of the device **10**. The conformal layer may include a thin coating having a thickness of between about 2 nm to about 15 nm. The conformal layer may be deposited using a CVD process, an atomic layer deposition (ALD) process or any other suitable conformal deposition process. The conformal layer may include, e.g., a nitride, oxynitride or other materials that can be selectively etched relative to surrounding materials. A reactive ion etch process is performed to remove the conformal spacer layer from horizontal surfaces and form spacers **24**.

Referring to FIG. 3, a cross-sectional view taken at section line 3-3 of FIG. 2 is shown. The fins **14** include the oxide **26** within the gate materials **22** (e.g., dummy gate). The oxide **26** can act as the gate dielectric for field effect transistors to be formed.

Referring to FIGS. 2 and 3, the oxide **26** is removed from the fins beyond the spacers **24** to expose the fins **14**. The removal of the oxide **26** leaves the surfaces of the fins **14** ready for epitaxially cladding for the formation of source/drain (S/D) regions as depicted in FIG. 4.

Referring to FIG. 4, portions of the fins **14** exposed by the removal of oxide **26** are prepared for the formation of S/D regions **28**. S/D regions **28** are grown on the fins **14** by an epitaxial deposition process.

The epitaxial deposition process can be done by ultrahigh vacuum chemical vapor deposition (UHVCVD), rapid ther-

mal chemical vapor deposition (RTCVD), metalorganic chemical vapor deposition (MOCVD), low-pressure chemical vapor deposition (LPCVD), limited reaction processing CVD (LRPCVD), molecular beam epitaxy (MBE), etc. Epitaxial materials may be grown from gaseous or liquid precursors. Epitaxial materials may be grown using vapor-phase epitaxy (VPE), molecular-beam epitaxy (MBE), liquid-phase epitaxy (LPE), or other suitable process.

The terms "epitaxial growth and/or deposition" and "epitaxially formed and/or grown," mean the growth of a semiconductor material (crystalline material) on a deposition surface of another semiconductor material (crystalline material), in which the semiconductor material being grown (crystalline over layer) has substantially the same crystalline characteristics as the semiconductor material of the deposition surface (seed material). In an epitaxial deposition process, the chemical reactants provided by the source gases are controlled, and the system parameters are set so that the depositing atoms arrive at the deposition surface of the semiconductor substrate with sufficient energy to move about on the surface such that the depositing atoms orient themselves to the crystal arrangement of the atoms of the deposition surface. Therefore, an epitaxially grown semiconductor material has substantially the same crystalline characteristics as the deposition surface on which the epitaxially grown material is formed. For example, an epitaxially grown semiconductor material deposited on a {100} orientated crystalline surface will take on a {100} orientation. In some embodiments, epitaxial growth and/or deposition processes are selective to forming on semiconductor surface, and generally do not deposit material on exposed surfaces, such as silicon dioxide or silicon nitride surfaces.

In one embodiment, epitaxial silicon is grown in the presence of a phosphine flow to form thermally stable  $\text{Si}_3\text{P}_4$ . It should be understood that while  $\text{Si}_3\text{P}_4$  is preferred, other materials may be formed that can be subjected to selective annealing to provide wimpy and nominal devices in accordance with the present principles.

A gas precursor selected from the group consisting of tertiary-butylphosphine (TBP), phosphine ( $\text{PH}_3$ ), alkylphosphines, such as with the empirical formula  $\text{R}_x\text{PH}_{(3-x)}$ , where R=methyl, ethyl, propyl or butyl and  $x=1, 2$  or  $3$  and/or combinations thereof may be employed. Alkylphosphines include trimethylphosphine ( $(\text{CH}_3)_3\text{P}$ ), dimethylphosphine ( $(\text{CH}_3)_2\text{PH}$ ), triethylphosphine ( $(\text{CH}_3\text{CH}_2)_3\text{P}$ ) and diethylphosphine ( $(\text{CH}_3\text{CH}_2)_2\text{PH}$ ). The temperature for epitaxial deposition ranges from between, e.g., about 400 degrees C. to about 1000 degrees C.

The S/D regions **28** may be grown on a single fin **14** or on multiple fins **14**. The  $\text{Si}_3\text{P}_4$  provides strained S/D regions **28**. In one embodiment, the stress of  $\text{Si}_3\text{P}_4$  may be close to about 1.6 GPa with process optimization, which provides a corresponding strain. Strained S/D regions can transfer about one half the strain to a channel region (e.g., the fin region below the gate structure **20**). The  $\text{Si}_3\text{P}_4$  provides tensile strain that can lead to lower threshold voltage ( $V_t$ ) for silicon n-type field effect transistors (nFETs).

To this point, the processing of the finFETs has been the same. In this way, wimpy devices and nominal devices are indistinguishable. In accordance with a device design, transistors will be designated for selective annealing to convert their threshold voltage.

Referring to FIG. 5, a block mask **30** is deposited over the device **10**. The block mask **30** is patterned by lithography (e.g., photo lithography or electron beam lithography). In one embodiment, the block mask **30** includes a material that is reflective of laser light at a wavelength(s) of the laser light,

e.g., metals such as e.g., Ag, Al, Cu, alloys of these or other materials containing metals may be employed. In this way, the block mask **30** protects a covered device **32** from laser light during a selective anneal process of an exposed device **34**.

In accordance with one embodiment, laser selective annealing (LSA) may be employed to heat the epitaxially grown regions of exposed device **34** at or above about 1200 degrees C. The anneal may last for a few milliseconds (e.g., 2-6 milliseconds). The anneal relaxes the strain in the device **34**, but also increases the active phosphorus amount by decomposition of the  $\text{Si}_3\text{P}_4$  compound. The resistance of relaxed  $\text{Si}_3\text{P}_4$  **36** of device **34** is nearly the same as strained  $\text{Si}_3\text{P}_4$  in device **32**. In this way, a threshold voltage of the devices **34** is altered while maintaining a common processing of the semiconductor devices.

In one embodiment, the threshold voltage ( $V_t$ ) of the exposed devices **34** is larger than the covered devices **32**. In one embodiment, the devices **32** and **34** have a same gate length (Lg), same contact pitch and/or gate pitch (CPP), and a same channel doping. This permits fewer changes to the process flow and results in a simpler design and reduced processing costs. Wimpy and nominal devices are formed together and include similar structures and materials. The block mask **30** is removed from over the covered device **32**.

Referring to FIG. 6, after the block mask **30** is removed, a gate cut process is performed to define gate dimensions and to separate gate structures between wimpy devices **34** and nominal devices **32**. The gate cut includes a lithographic pattern and etch process to form a space **44** between portions of the gate structure.

If a dummy gate is employed, a replacement metal gate (RMG) process may be performed to replace the dummy gate with a replacement gate. This may include a dielectric fill, which is applied to the device **10**. The dielectric fills in between gate structures and covers S/D regions **28**, **36**. The dielectric fill may include an oxide, such as a silicon oxide or may include polysilicon. Other materials may also be employed.

A planarization process, e.g., chemical mechanical polishing (CMP) is performed. The planarization process removes dielectric fill from a top surface and to expose the dummy gate (gate material **22**). An etch process, such as, e.g., RIE is employed to selectively etch away the gate material **22** down to the STI **16** and remove oxide **26** from the fins **14**.

A dielectric material **42** or the like is deposited over the fins **14** in between the spacers **24** to form a gate dielectric (**42**) as depicted in FIG. 7. FIG. 7 is a cross-sectional view of the gate conductors **38**, **40** taken at section line 7-7 of FIG. 6.

The gate dielectric **42** may be an oxide, nitride and oxynitride material. In one embodiment, the gate dielectric **42** may be composed of a high-k dielectric layer, i.e., a dielectric having a dielectric constant that is greater than 4.0, as measured at room temperature. Such higher dielectric constant dielectric materials may include, but are not limited to, hafnium oxides, hafnium silicates, titanium oxides, barium-strontium-titanates (BSTs) and lead-zirconate-titanates (PZTs). In one embodiment, the gate dielectric **42** has a thickness ranging from 5 angstroms to 200 angstroms.

A conductive material (replacement metal) is deposited and planarized to form gate conductors **38**, **40**. The gate conductors **38**, **40** may include, e.g., polycrystalline or amorphous silicon, germanium, silicon germanium, a metal (e.g., tungsten, titanium, tantalum, ruthenium, zirconium, cobalt, copper, aluminum, lead, platinum, tin, silver, gold),

a conducting metallic compound material (e.g., tantalum nitride, titanium nitride, tungsten silicide, tungsten nitride, ruthenium oxide, cobalt silicide, nickel silicide), carbon nanotube, conductive carbon, graphene, or any suitable combination of these materials.

Processing continues with the formation or processing of an interlevel dielectric layer (ILD) (not shown to depict the device structures). The ILD is patterned to form contact openings to the gate conductors **38**, **40** and the S/D regions **28**, **36**.

In accordance with the present principles, nominal devices **32** are formed with strained  $\text{Si}_3\text{P}_4$  S/D regions **28** to create devices with lower  $V_t$ , and wimpy devices **34** are formed with relaxed  $\text{Si}_3\text{P}_4$  S/D regions **36** to create devices with higher  $V_t$ .

Referring to FIG. 8, methods for co-integrating wimpy and nominal devices are illustratively shown in accordance with the present principles. In some alternative implementations, the functions noted in the blocks may occur out of the order noted in the figures. For example, two blocks shown in succession may, in fact, be executed substantially concurrently, or the blocks may sometimes be executed in the reverse order, depending upon the functionality involved. It will also be noted that each block of the block diagrams and/or flowchart illustration, and combinations of blocks in the block diagrams and/or flowchart illustration, can be implemented by special purpose hardware-based systems that perform the specified functions or acts or carry out combinations of special purpose hardware and computer instructions.

In block **102**, fins are optionally formed on or in a substrate. In block **104**, a shallow trench isolation (STI) region may be formed at the base of the fins. In block **106**, a gate structure is formed (e.g., over the fins or on a planar region). In block **108**, in one embodiment, the gate structure is formed using a dummy gate; and the dummy gate will be replaced later with a gate conductor after the source/drain regions are formed. In block **110**, in another embodiment, the gate structure includes a gate conductor before the source/drain regions are formed.

In block **112**, source/drain regions are grown on semiconductor material adjacent to the gate structure to form device structures with a non-electrically active material (e.g.,  $\text{Si}_3\text{P}_4$ ). The semiconductor material may be planar or include fins. In block **114**, in one embodiment, source/drain regions are grown by epitaxially growing silicon in an abundance of phosphine.

In block **116**, selected device structures are masked with a block mask. If lasers are employed for selective annealing in a next step, the block mask includes a reflective block mask to reflect laser light.

In block **118**, unmasked device structures are selectively annealed to increase electrical activity of the non-electrically active material to adjust a threshold voltage between the selected device structures and the unmasked device structures. In one embodiment, selectively annealing the unmasked device structures includes exposing the unmasked device structures to laser light. The selective anneal includes annealing to 1200 degrees C. or greater, e.g., for a non-electrically active material that includes, e.g.,  $\text{Si}_3\text{P}_4$ . The selected device structures (e.g., nominal devices) and the unmasked device structures (e.g., wimpy devices) are formed by a same process (except for stress relieving by selective anneal), and therefore have a same gate length, same channel doping, same contact pitch, etc. In block **120**, processing continues to complete the device.

Having described preferred embodiments wimpy device by selective laser annealing (which are intended to be illustrative and not limiting), it is noted that modifications and variations can be made by persons skilled in the art in light of the above teachings. It is therefore to be understood that changes may be made in the particular embodiments disclosed which are within the scope of the invention as outlined by the appended claims. Having thus described aspects of the invention, with the details and particularity required by the patent laws, what is claimed and desired protected by Letters Patent is set forth in the appended claims.

What is claimed is:

1. A device having co-integrated wimpy and nominal transistors, comprising:
  - nominal transistors including first source/drain regions formed with a semiconductor alloy imparting strain into a first channel region; and
  - wimpy transistors including second source/drain regions formed with the semiconductor alloy that has been decomposed to include a larger amount of an electrically active atomic element than contained in the semiconductor alloy of the first source/drain region, wherein the wimpy device structures have a same gate length, a same channel dopant, and a same contact pitch as the nominal device structures.
2. The device as recited in claim 1, wherein each of the first source/drain regions and the second source/drain regions include silicon phosphide ( $\text{Si}_3\text{P}_4$ ).
3. The device as recited in claim 1, wherein the second source/drain regions include more electrically active phosphorous than the first source/drain regions due to selective laser annealing.
4. The device as recited in claim 1, wherein the first source/drain regions and the second source/drain regions have substantially the same resistance.
5. The device as recited in claim 1, wherein the first source/drain regions and the second source/drain regions are formed on a dielectric layer.
6. The device as recited in claim 1, wherein the first source/drain regions and the second source/drain regions are formed on fins etched from a semiconductor material.
7. The device as recited in claim 1, wherein the first source/drain regions transfer about half of a stress introduced by the semiconductor alloy into channel regions.
8. The device as recited in claim 1, wherein the first channel region is in a first gate structure including a first gate conductor and first spacer layers; and further comprising, a second channel region in a second gate structure including a second gate conductor and second spacer layers.

9. The device as recited in claim 8, wherein the first source/drain regions are adjacent to the first spacer layers; and
  - the second source/drain regions are adjacent to the second spacer layers.
10. The device as recited in claim 1, wherein the first source/drain regions have a stress of about 1.6 GPa due to the semiconductor alloy.
11. A device having co-integrated wimpy and nominal transistors, comprising:
  - first fins and second fins formed on a substrate;
  - first source/drain regions formed on the first fins adjacent to a first gate structure to form nominal device structures with a first material; and
  - second source/drain regions formed on the second fins adjacent to a second gate structure to form wimpy device structures with a second material formed of decomposed first material;
 wherein the wimpy device structures have a different concentration of an electrically conductive atomic element than the nominal device structures such that the wimpy device structures have different threshold voltages than the nominal device structures.
12. The device as recited in claim 11, wherein the first material includes a  $\text{Si}_3\text{P}_4$  material.
13. The device as recited in claim 11, wherein the wimpy device structures have a same gate length, same channel doping and same contact pitch as the nominal device structures.
14. The device as recited in claim 11, wherein the first source/drain regions include strained material and the second source/drain regions include relaxed material due to laser selective annealing.
15. The device as recited in claim 11, wherein the second source/drain regions include more electrically active phosphorous than the first source/drain regions due to selective laser annealing.
16. The device as recited in claim 11, wherein the first source/drain regions and the second source/drain regions have substantially the same resistance.
17. The device as recited in claim 11, wherein the first source/drain regions and the second source/drain regions are formed on a dielectric layer.
18. The device as recited in claim 11, wherein the first source/drain regions transfer about half of stress introduced by the first material into channel regions.
19. The device as recited in claim 11, wherein the first gate structure includes a first gate conductor and first spacer layers; and
  - the second gate structure includes a second gate conductor and second spacer layers.

\* \* \* \* \*