

J. MOUNT.
Car Coupling.

No. 110,776.

Patented Jan. 3, 1871.

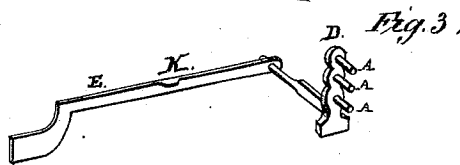
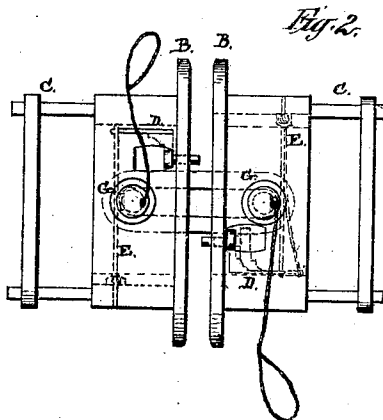
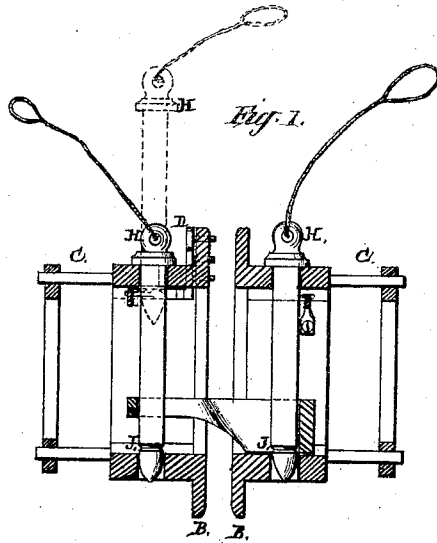

Witnesses
S. H. Reigart,
John Matthews.

Joseph Mount

United States Patent Office.

JOSEPH MOUNT, OF MONROE TOWNSHIP, NEW JERSEY.

Letters Patent No. 110,776, dated January 3, 1871.

IMPROVEMENT IN CAR-COUPLINGS.

The Schedule referred to in these Letters Patent and making part of the same.

To all whom it may concern:

Be it known that I, JOSEPH MOUNT, of Monroe Township, Middlesex county, State of New Jersey, have invented an "Improved Car-Coupling, self-connecting;" and I do hereby declare the following to be an exact description thereof, reference being had to the accompanying drawing, and to the letters of reference marked thereon making a part of this specification, in which—

Figure 1 represents a side sectional elevation of the car-coupling

Figure 2, a top view of the same.

Figure 3 shows the coupling devices, arm, spring, and triple heads.

The nature of my invention consists in the construction and combination of the arm with its spring at one end and three heads at the upper end or shoulder of the arm, and a groove around the coupling-bolt, all operating on the inside of the bumper, while the construction of the link allows it to be held in a perfectly horizontal position so as to make a certain and un-failing connection.

The object of my invention is that the cars can be self-connecting on a curve of the railroad as well as on a straight line; and when required to be disconnected, the bumpers can be instantly uncoupled without endangering the life or limb of the operator.

The simplicity and durability of the coupling devices make the invention most useful and practical.

A A A are one, two, or three heads, that project and operate through apertures in the flange B of the bumper C. They are permanently attached to the shoulder at the upper end of the arm D. The should-

der of the arm D plays or operates in a recess on the inner side of the flange B of the bumper.

The flat spring E extends across the inside of the bumper C, underneath the aperture G in which the coupling-pin H is dropped or raised.

The one end of the spring E is permanently riveted or attached to the lower end of the arm D, and the other end of the spring is permanently fastened to the opposite and inside of the bumper.

At the top of the beveled point of the coupling-pin or bolt H is a groove, J, surrounding the pin that rests upon the tongue K at the center of the spring E, until the cars or couplings come in contact, when the heads A are forced back and press the spring E back, which relieves the upright H and allows the bolt to drop down into the link below.

The construction of the devices is such that they may be adapted to the draw-heads in common use.

Therefore I do not broadly claim a spring stop for the pin, automatically released by the collision of the bumpers; but

What I do claim, and desire to secure by Letters Patent, is—

The spring E, provided with the lug K, fitting into a groove in the pointed pin, the spring being rigidly attached at one end and moved at the other by the arm D, which has projections *a a a* (one or more) through the face of the draw-head, the whole being adapted to draw-heads of the ordinary construction, and operating as set forth.

Witnesses:

JOSEPH MOUNT.

J. FRANKLIN REIGART,
EDM. F. BROWN.