



US 20040004270A1

(19) **United States**

(12) **Patent Application Publication**
Lombardo et al.

(10) **Pub. No.: US 2004/0004270 A1**

(43) **Pub. Date: Jan. 8, 2004**

(54) **GERMANIUM IMPLANTED HBT BIPOLAR**

(30) **Foreign Application Priority Data**

May 30, 1997 (EP) 97830259.4

(75) Inventors: **Salvatore Lombardo**, Catania (IT);
Maria Concetta Nicotra, Catania (IT);
Angelo Pinto, Augusta (IT)

Publication Classification

(51) **Int. Cl.⁷** **H01L 27/082**; H01L 27/102;
H01L 29/70; H01L 31/11

(52) **U.S. Cl.** **257/565**

Correspondence Address:
**SEED INTELLECTUAL PROPERTY LAW
GROUP PLLC
701 FIFTH AVE
SUITE 6300
SEATTLE, WA 98104-7092 (US)**

(57) **ABSTRACT**

A vertical structure high carrier mobility transistor on a substrate of crystalline silicon doped with impurities of the N type, the transistor having a collector region located at a lower portion of the substrate. The transistor includes a heterostructure alloy region positioned in the substrate and comprised of a heterostructure alloy of silicon and germanium. A base region is positioned in the substrate above the first conducting region and doped with P-type impurities. A first dielectric layer is positioned on, and directly contacts, the heterostructure alloy region, and defines a first window directly above the heterostructure alloy region. The transistor also includes an emitter positioned in the heterostructure alloy region and between the first window and the base region. The emitter is comprised of the heterostructure alloy doped with impurities of the first type and directly contacts the first dielectric layer.

(73) Assignee: **STMicroelectronics S.r.l.**, Agrate
Brianza (IT)

(21) Appl. No.: **10/615,084**

(22) Filed: **Jul. 7, 2003**

Related U.S. Application Data

(60) Division of application No. 09/724,563, filed on Nov. 27, 2000, now Pat. No. 6,624,017, which is a continuation of application No. 09/087,398, filed on May 29, 1998, now abandoned.

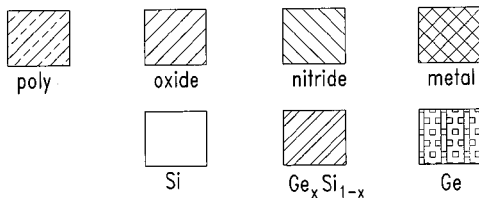
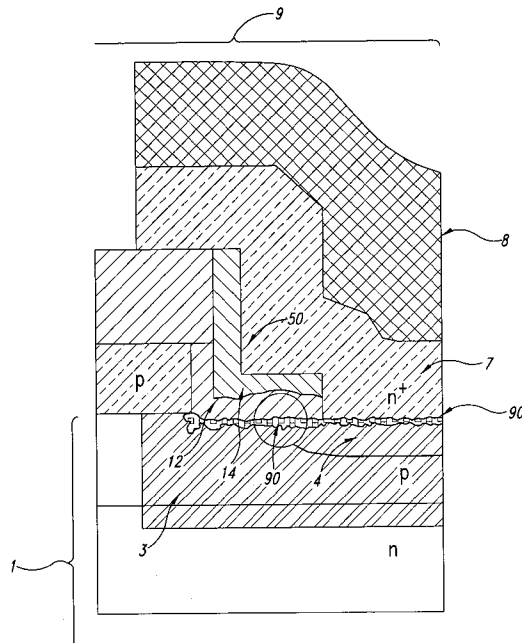

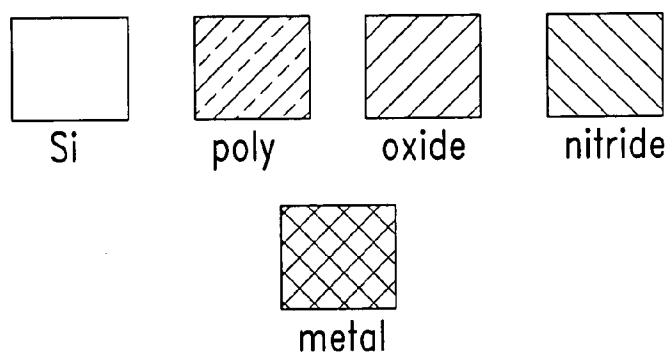
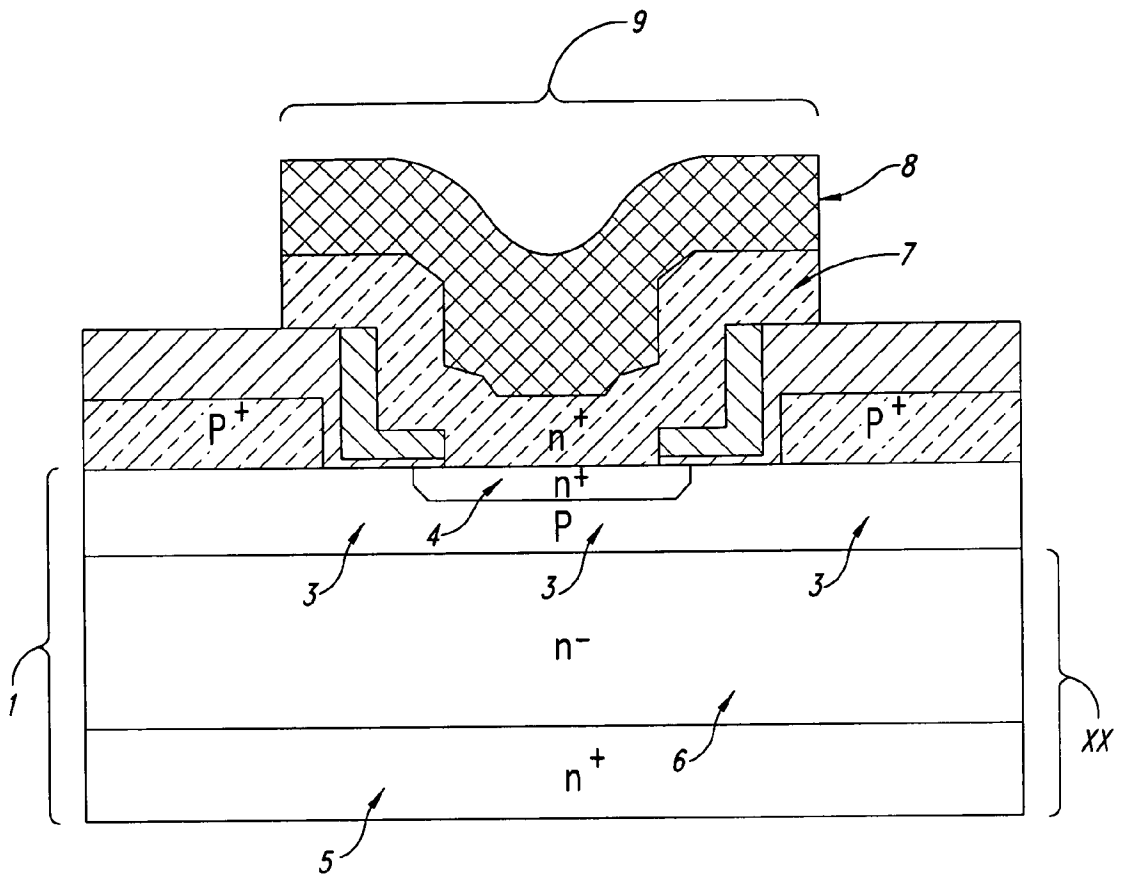

FIG. 1
(Prior Art)

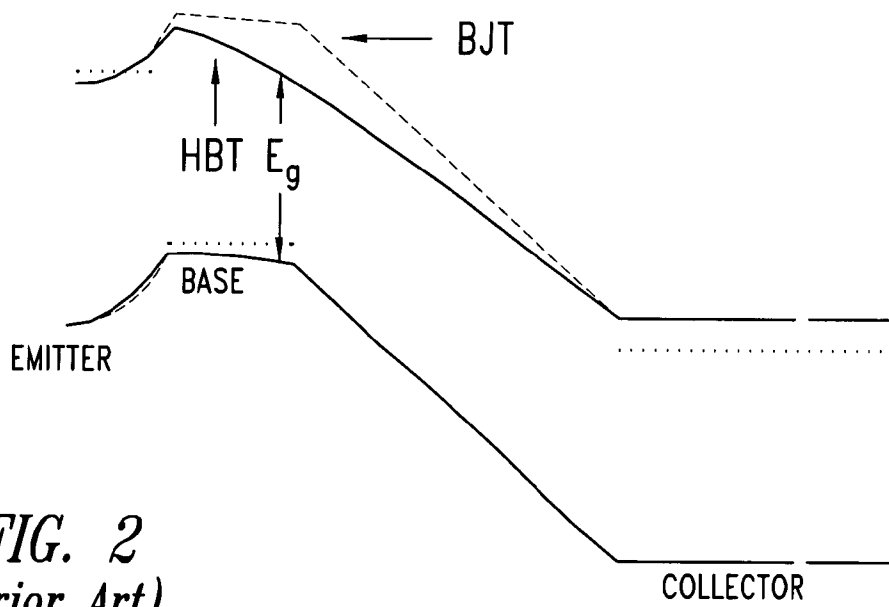

FIG. 2
(Prior Art)

FIG. 3A
(Prior Art)

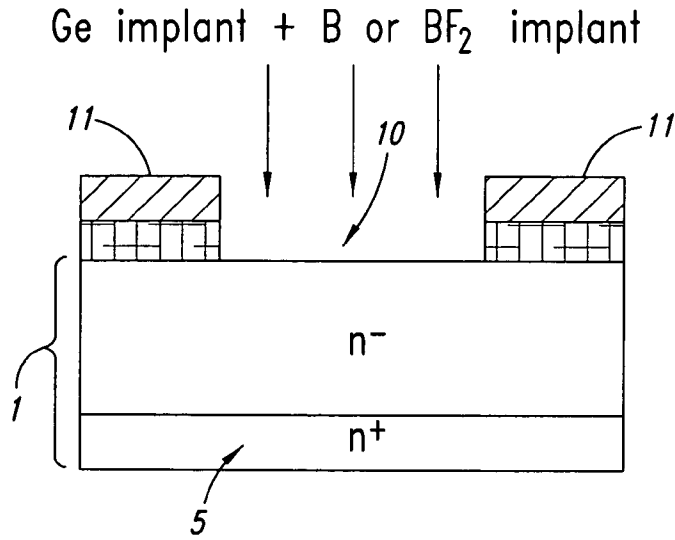

FIG. 3B
(Prior Art)

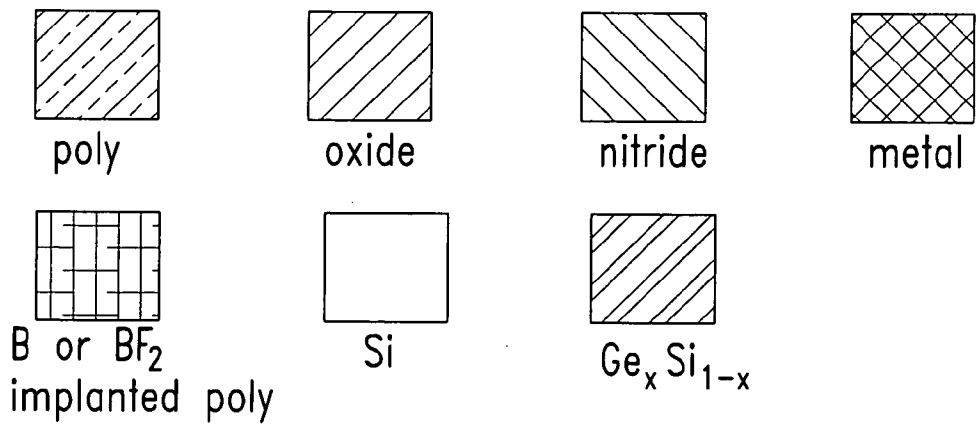
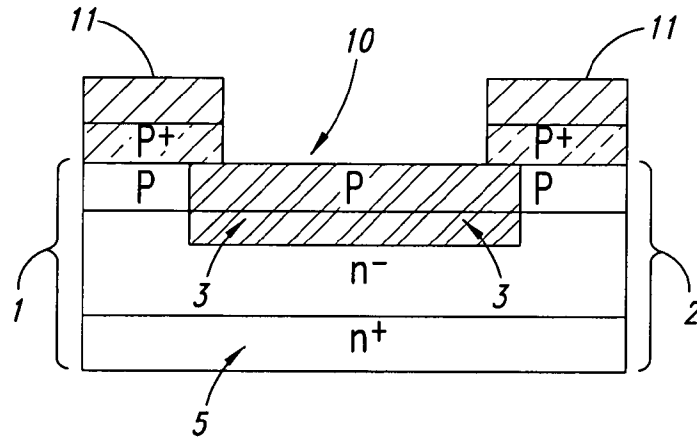

FIG. 3C
(Prior Art)

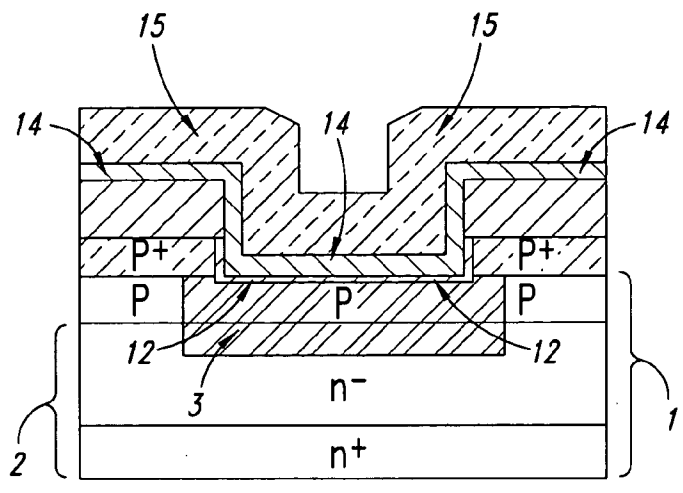

FIG. 3D
(Prior Art)

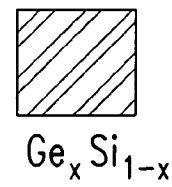
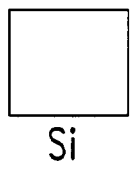
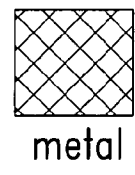
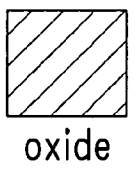
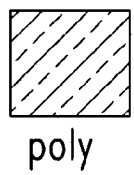
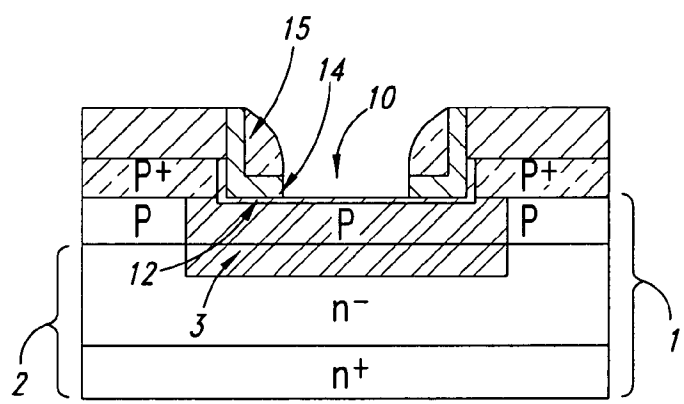

FIG. 3E
(Prior Art)

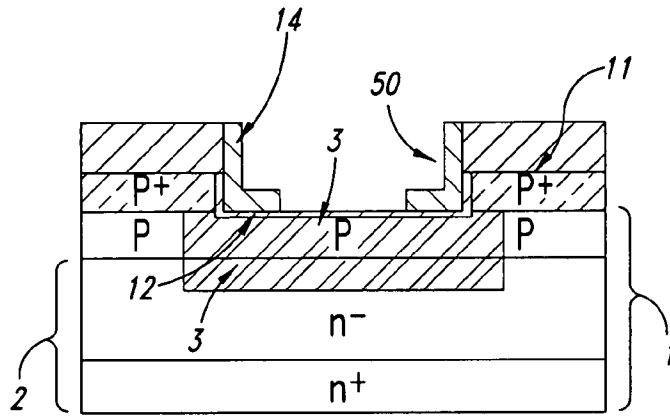
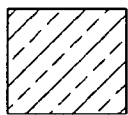
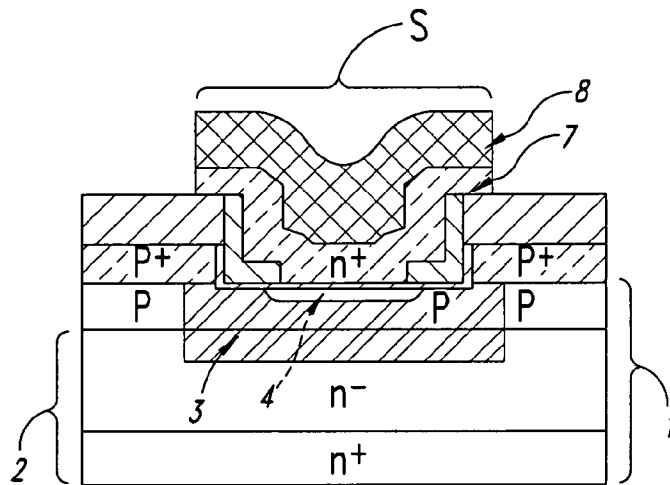
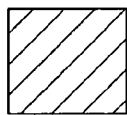

FIG. 3F
(Prior Art)



poly



oxide

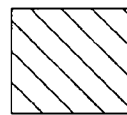

nitride

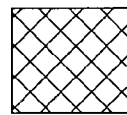

metal

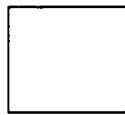

Si

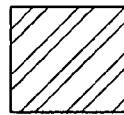

$Ge_x Si_{1-x}$

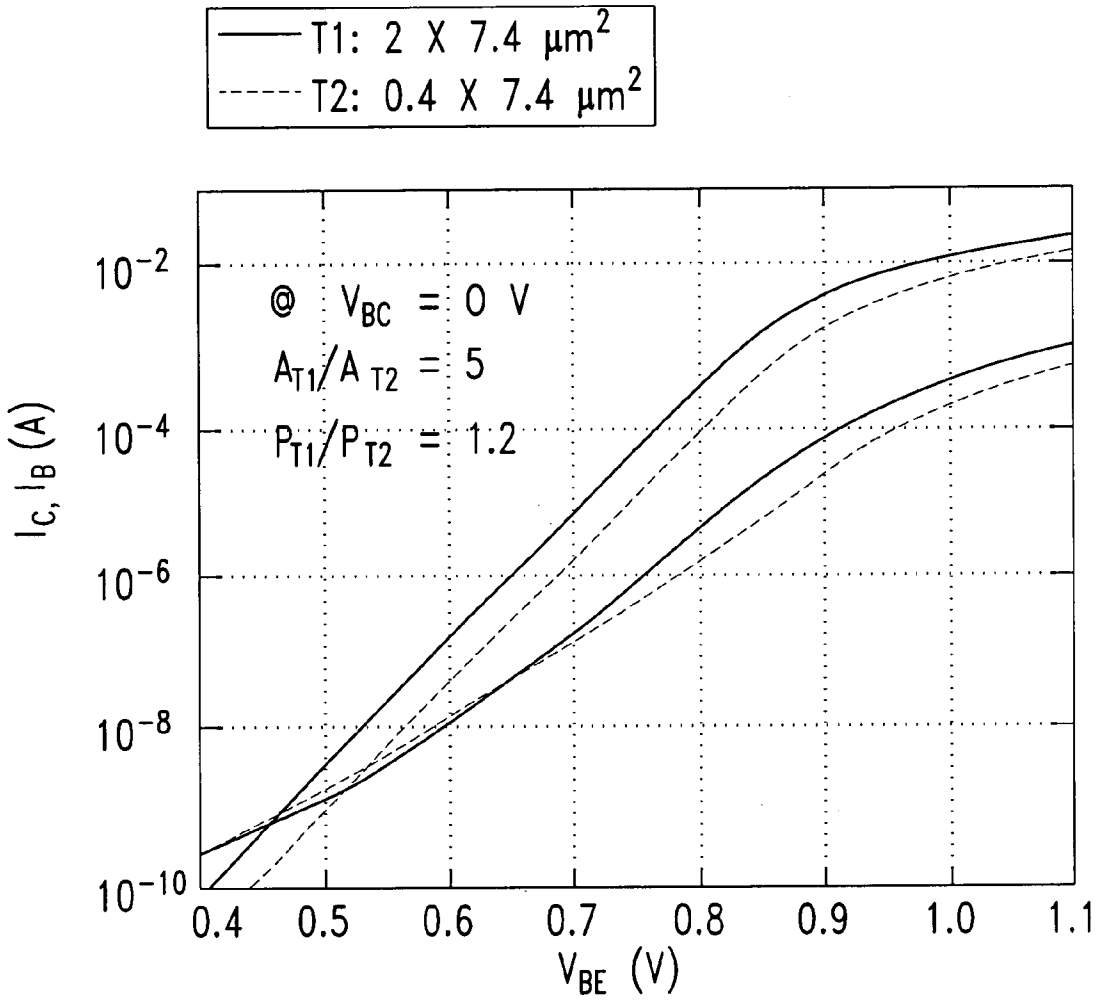

FIG. 4

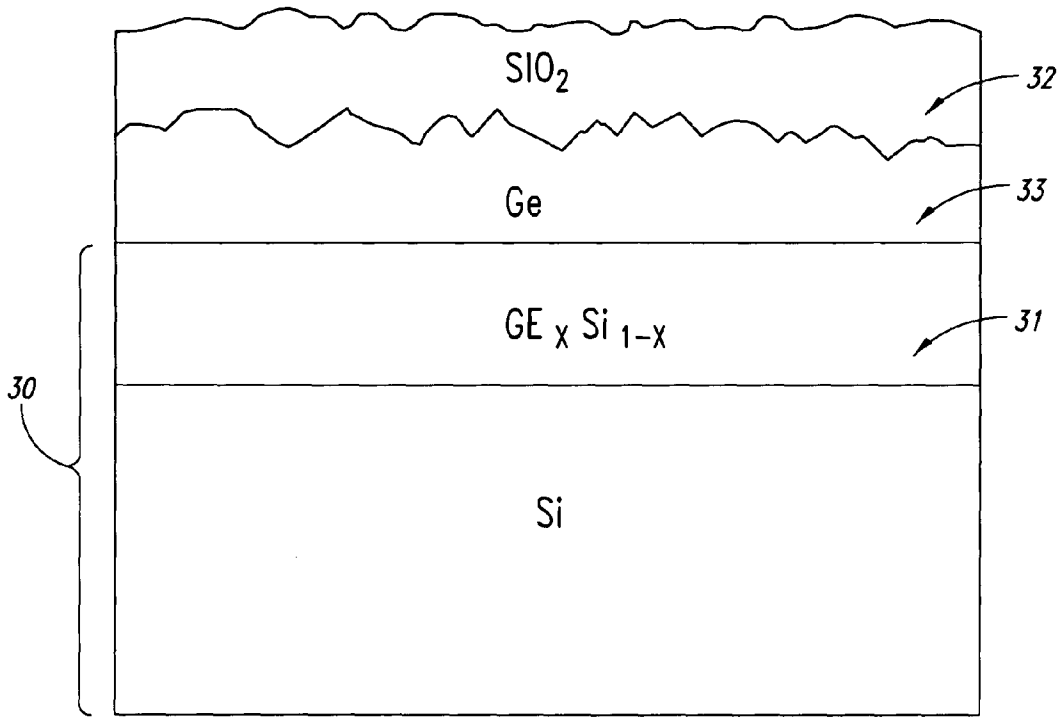

FIG. 5

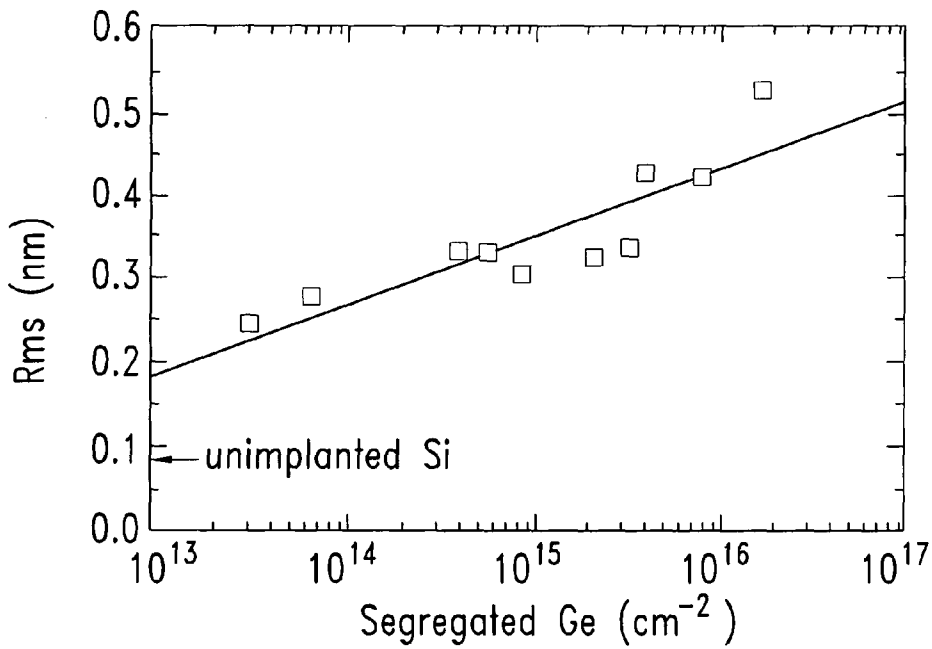

FIG. 7

Thermal oxide in
 $\text{Ge}_x\text{Si}_{1-x}$

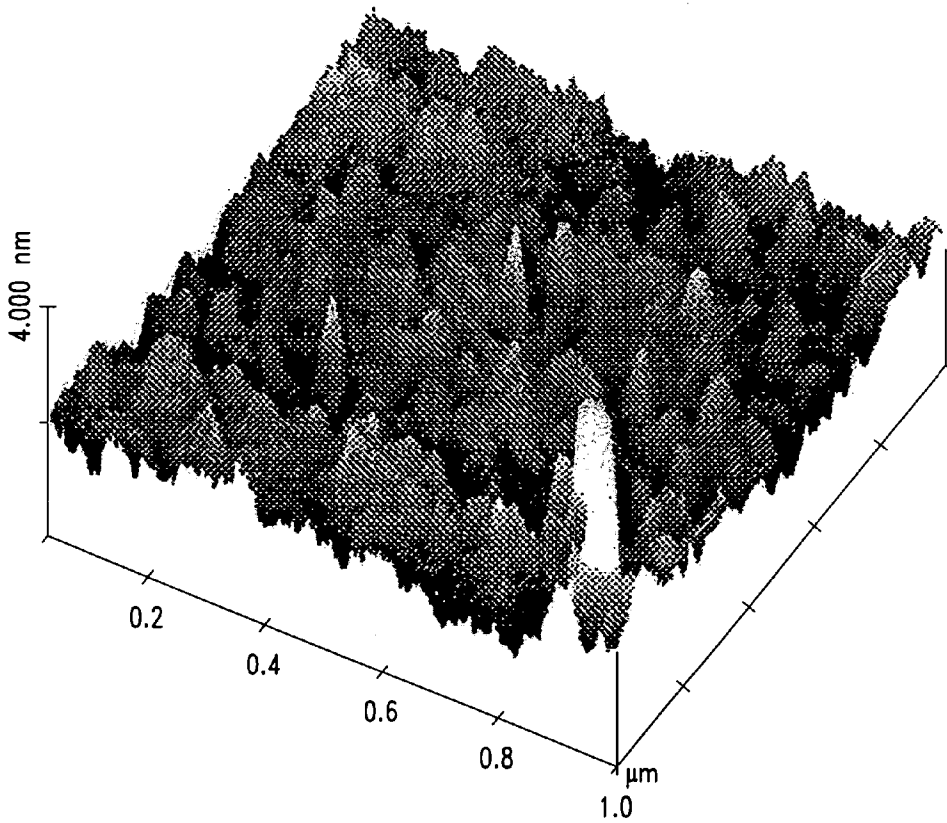

FIG. 6

poly

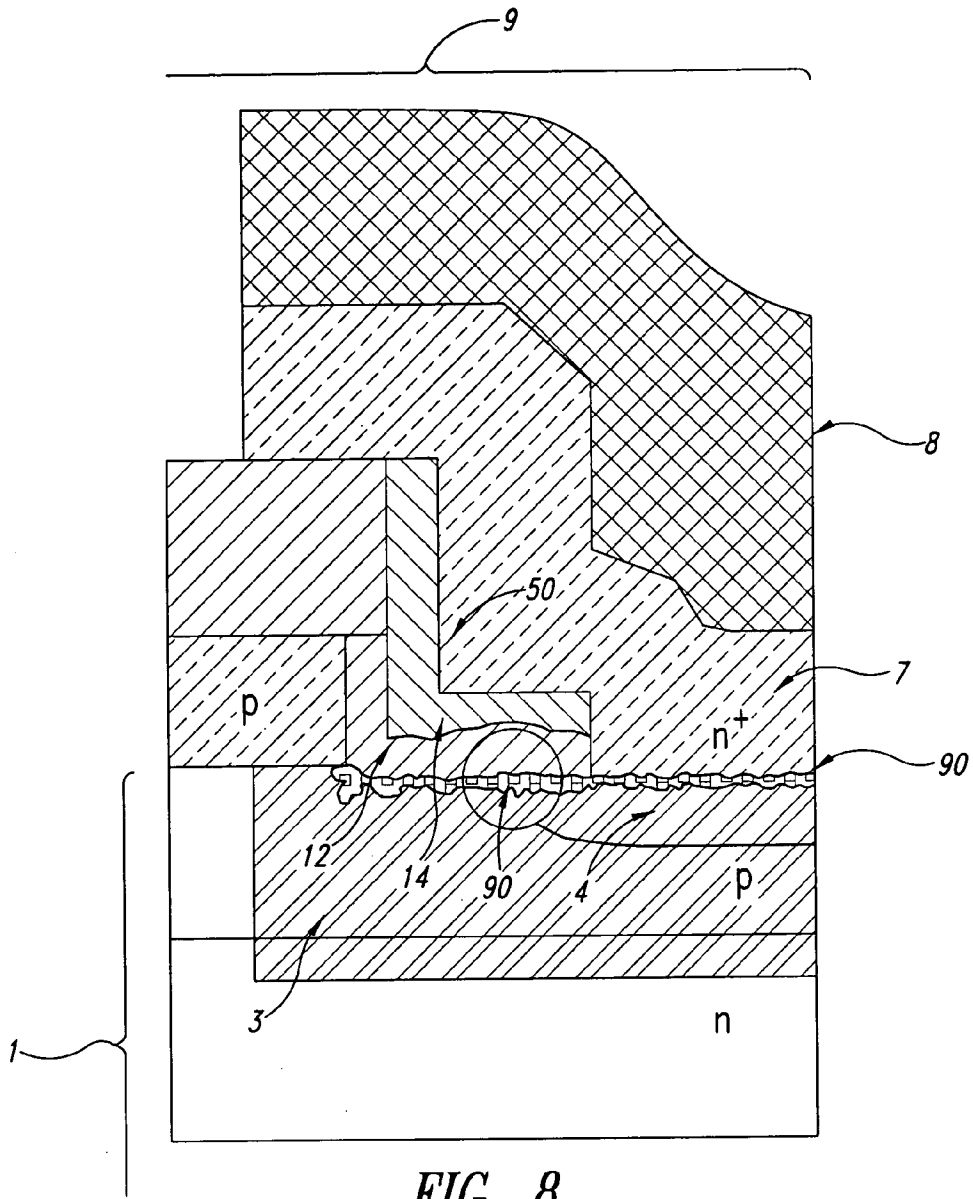

FIG. 8

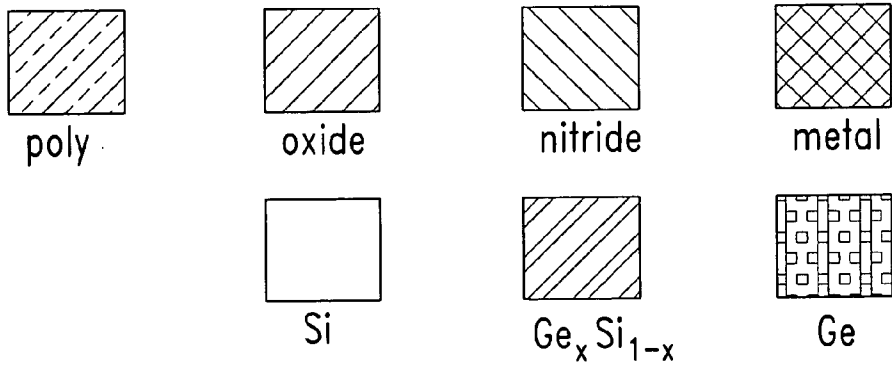

FIG. 9A

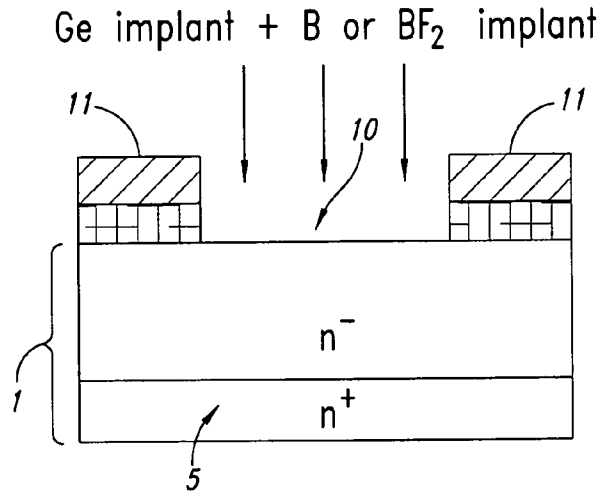

FIG. 9B

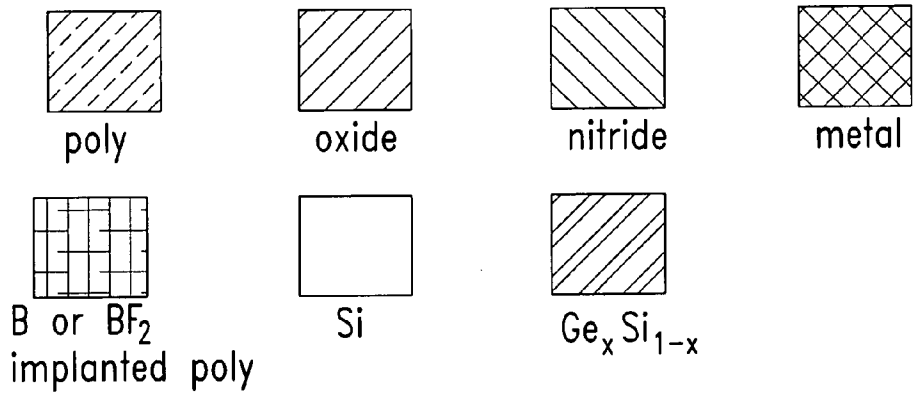
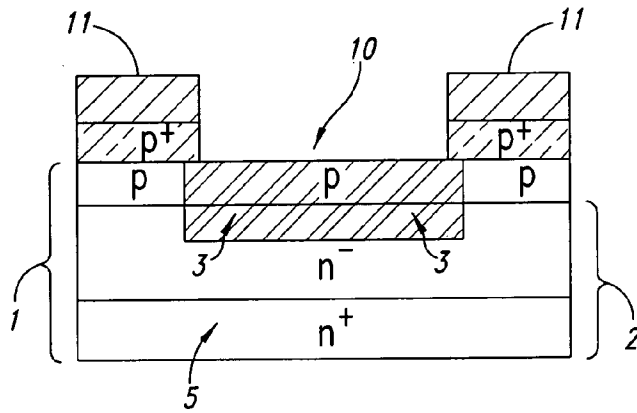

FIG. 9C

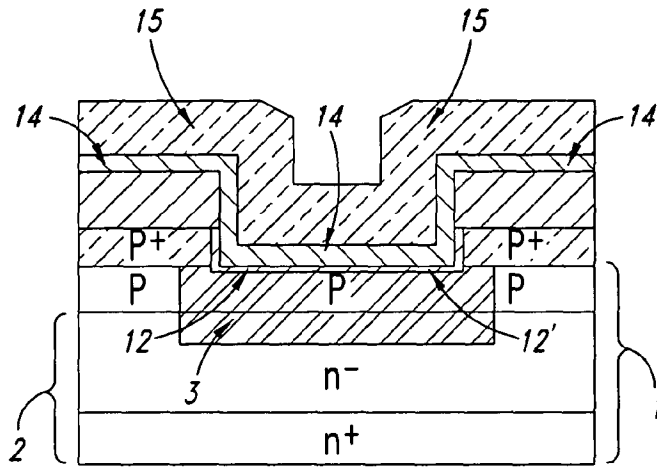
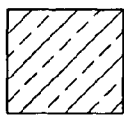
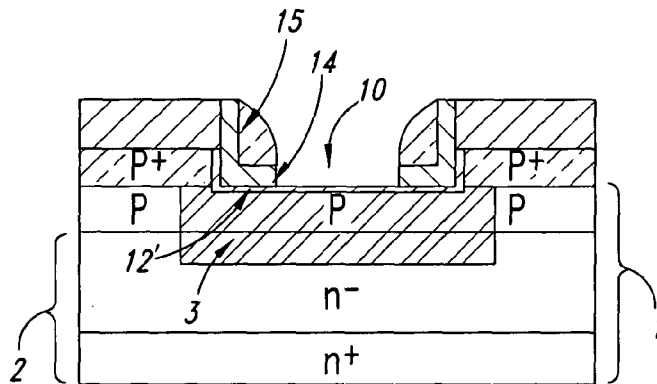
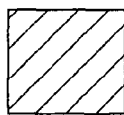

FIG. 9D



poly



oxide

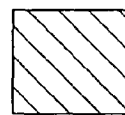

nitride

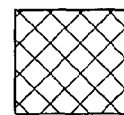

metal



Si

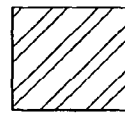

Ge_xSi_{1-x}

FIG. 9E

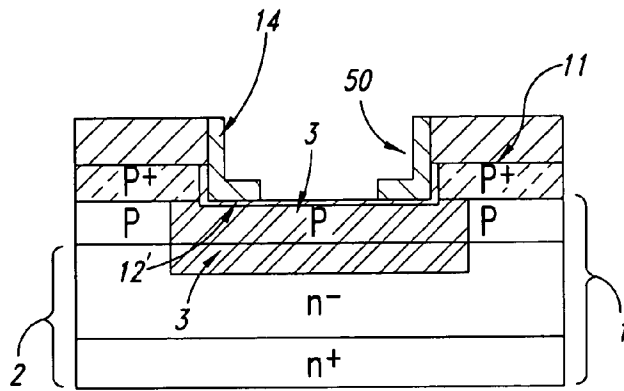
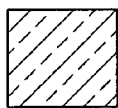
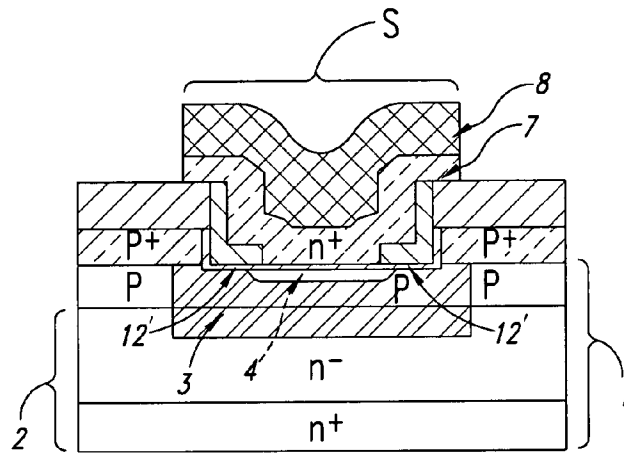
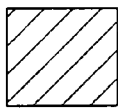

FIG. 9F



poly



oxide

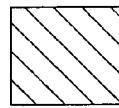

nitride

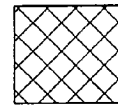

metal



Si

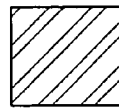

$Ge_x Si_{1-x}$

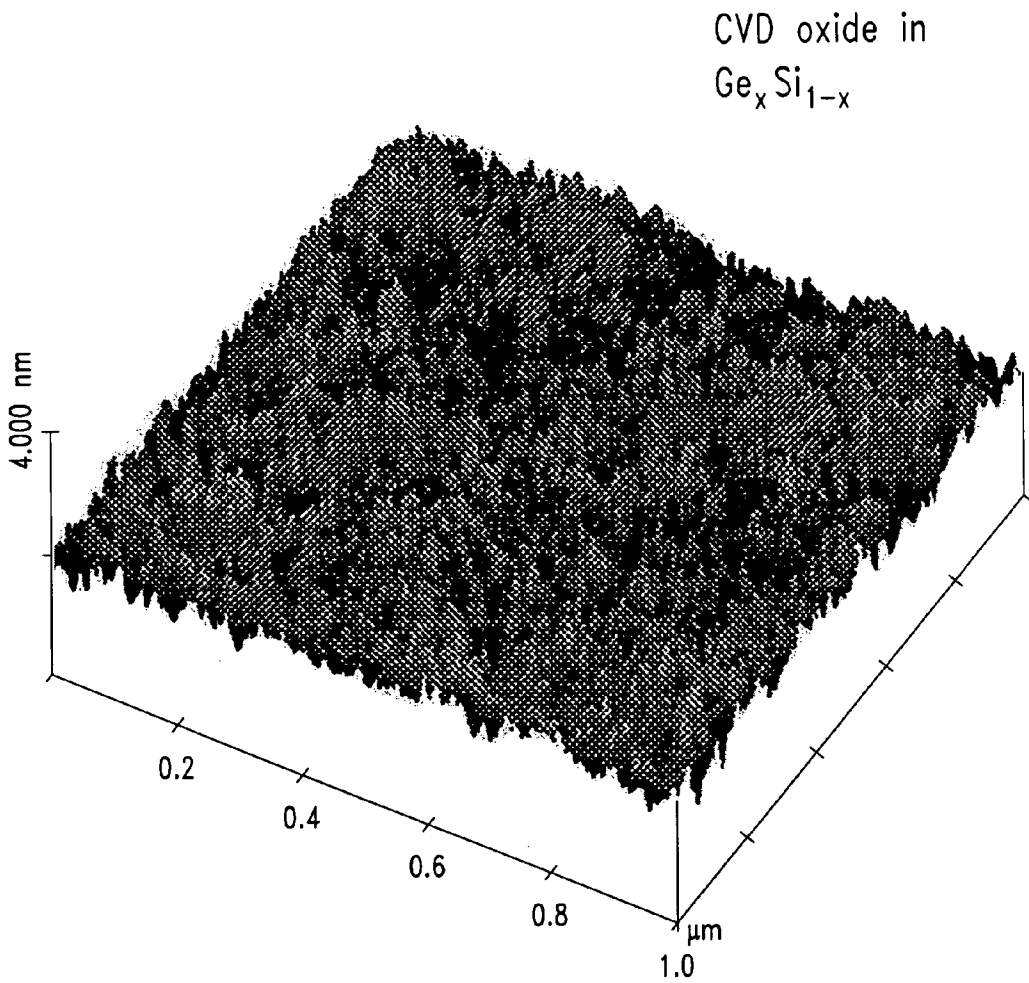

FIG. 10

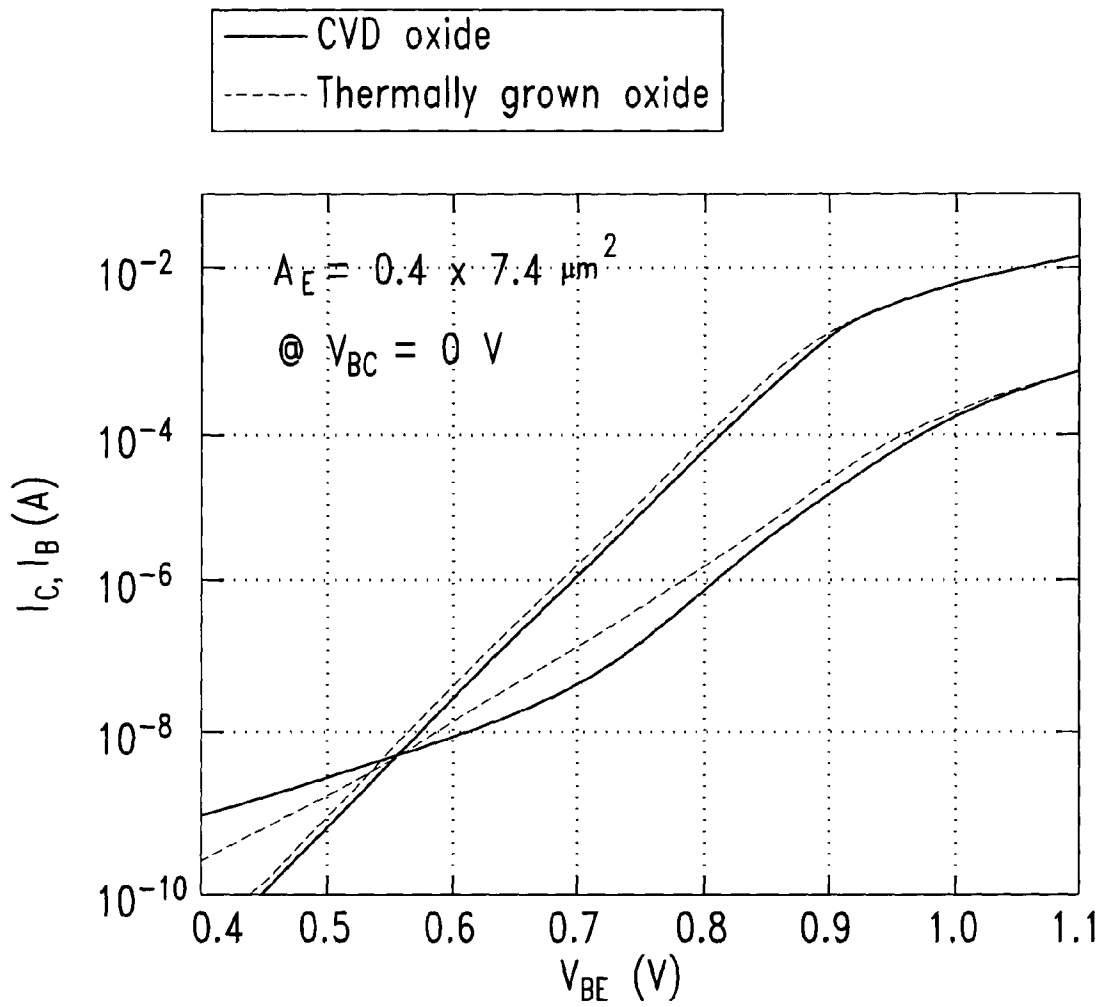

FIG. 11

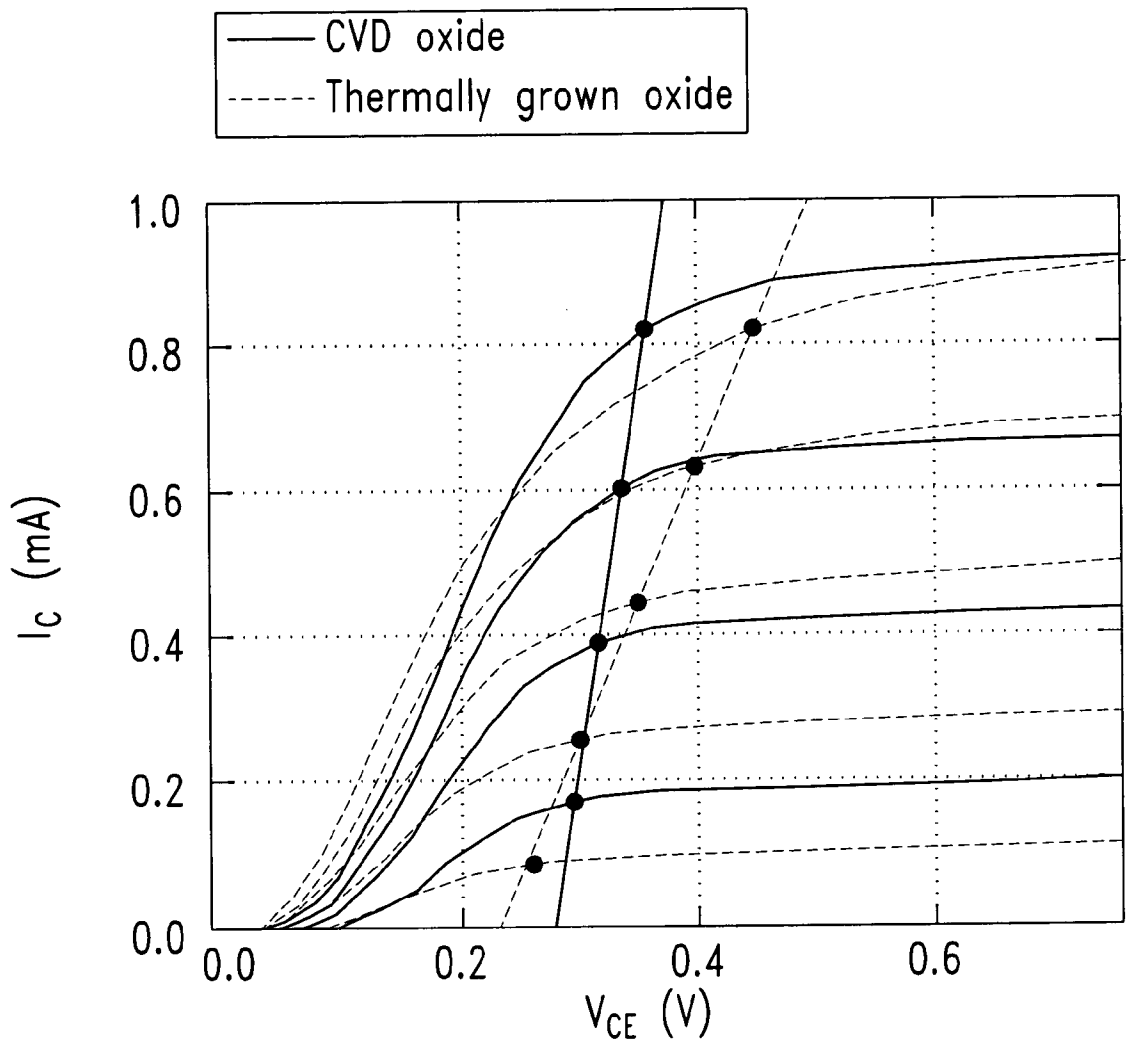

FIG. 12

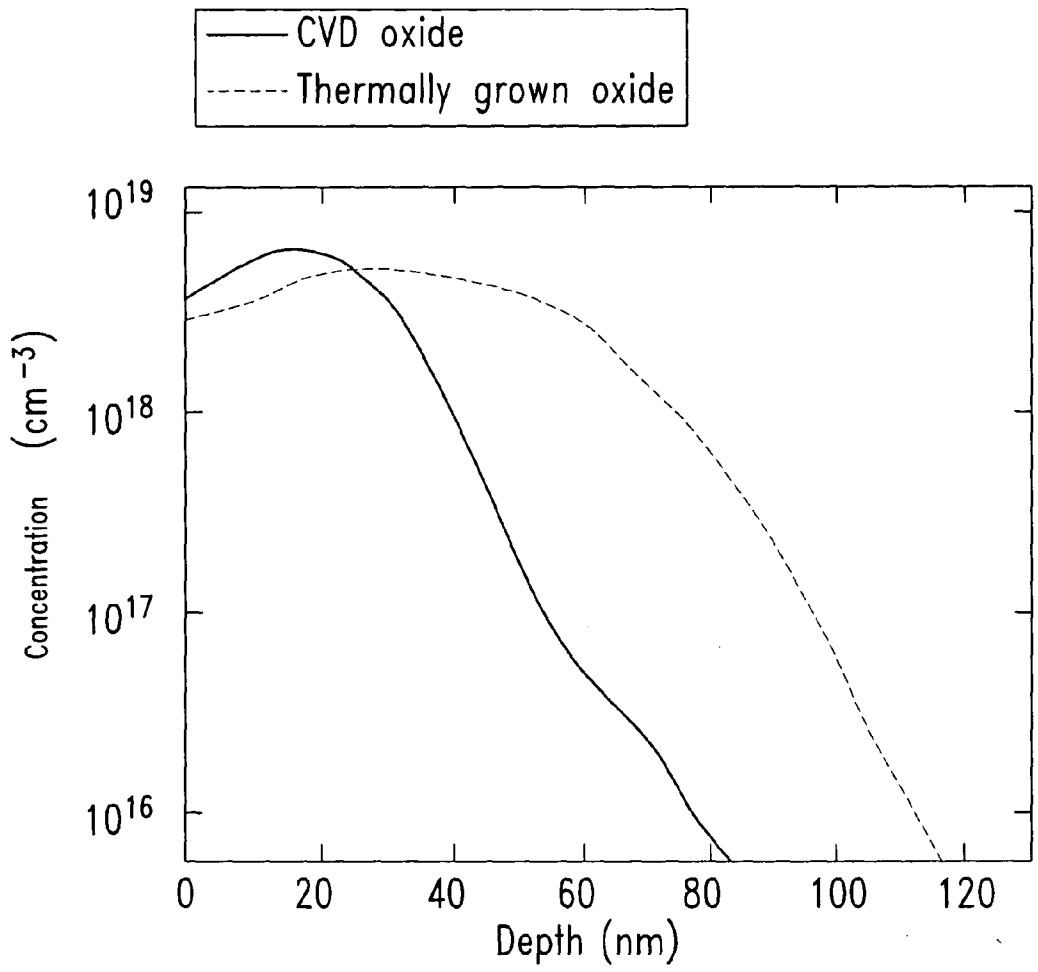

FIG. 13

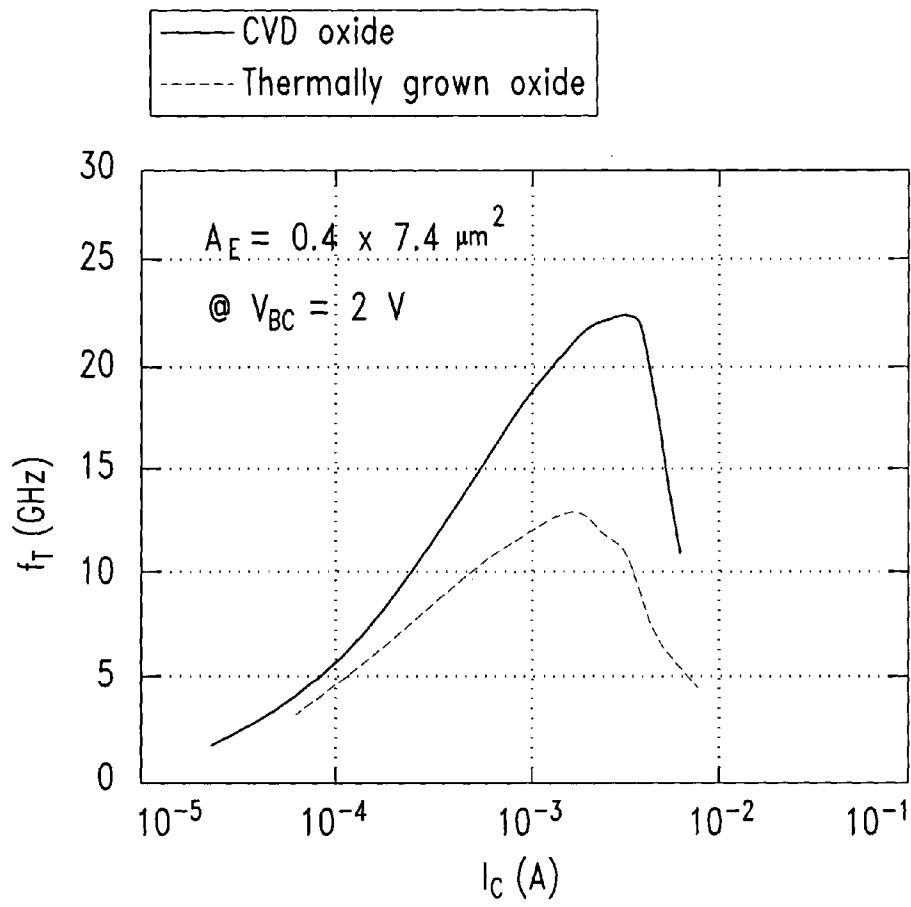

FIG. 14

GERMANIUM IMPLANTED HBT BIPOLAR

CROSS-REFERENCES TO RELATED APPLICATIONS

[0001] This application is a divisional of U.S. patent application Ser. No. 09/724,563, filed Nov. 27, 2000, now pending, which is a continuation of U.S. patent application Ser. No. 09/087,398, filed on Mar. 29, 1998, which applications are incorporated herein by reference in their entireties.

BACKGROUND OF THE INVENTION

[0002] 1. Field of the Invention

[0003] This invention relates generally to a process for fabricating a vertical structure high carrier mobility transistor on a crystalline silicon substrate, having a collector region located at a lower portion of the substrate.

[0004] The invention relates, particularly but not exclusively, to a process for fabricating a heterostructure bipolar transistor (HBT) for very high frequency applications, and the description to follow is given with reference to this applicational field for convenience of illustration.

[0005] 2. Description of the Related Art

[0006] As skilled persons in the art know well, the application of heterostructures to solid state electronic devices has prompted a vast increase of their working range at very high frequencies.

[0007] In particular, this technology has been applied to bipolar transistor devices, to thereby improve both the injection efficiency of the charge carriers and the passage frequency (f_p) value, the latter being closely related to the cut-off frequency (f_T) of the device.

[0008] Heterostructures can be prepared by different methods, of which the MBE (Molecular Beam Epitaxy) method is the best known and provides a structure free of lattice imperfections; other, more expensive methods are sophisticated versions of CVD which, however, have a disadvantage in that their throughput adds to the cost of the silicon die.

[0009] Yet this MBE method has only sparsely been applied to large volume industrial processes, on account of it involving lengthy processing steps that command strict control of their physical parameters.

[0010] Thus, it has often been more convenient to adopt other methods, such as ion implantation, which could yield similar heterostructures of a fair quality within acceptable times for large volume production lines.

[0011] A bipolar transistor implemented with a vertical structure including a $\text{Ge}_x\text{Si}_{1-x}$ heterostructure between the base and collector regions will now be described in relation to such a field of application.

[0012] The HBT bipolar transistor under consideration is illustrated schematically by the enlarged cross-sectional view of FIG. 1.

[0013] This HBT transistor has a vertical structure of the NPN type and is formed on a crystalline semiconductor substrate 1 wherein, by successive implantations, a collector

region 2 of the N type, a base region 3 of the P type, and an emitter region 4 of the N type have been defined, from the substrate bottom up.

[0014] Specifically, it can be seen that the collector region 2 includes a heavily N-doped layer 5 effective to provide a good ohmic contact with a collector metal (not shown because conventional) provided in a lower portion of the substrate 1.

[0015] An added feature of the HBT transistor shown in FIG. 1 is an opening provided above the substrate 1 to isolate the base region 3 and later allow formation of a contact region 9 above the emitter region 4.

[0016] This contact region 9 comprises a heavily N-doped layer 7 overlaid by a metal layer 8.

[0017] Having briefly described the HBT transistor, the $\text{Ge}_x\text{Si}_{1-x}$ heterostructure formed within the crystalline silicon substrate 1 will now be examined to see what changes are introduced in the energy band curve of the HBT transistor.

[0018] This $\text{Ge}_x\text{Si}_{1-x}$ heterostructure is characterized by the x and 1-x concentrations, respectively associated with the germanium and silicon atoms, varying with the spatial implant depth in the substrate 1.

[0019] In FIG. 2, the energy band curve of the bipolar transistor HBT is plotted as a full line for comparison with the band curve of a standard bipolar transistor (BJT), plotted as a broken line.

[0020] A comparison of the two band curves of the transistors HBT and BJT shows that the bipolar transistor HBT has an energy level in the conduction band which is always below that of the standard transistor BJT, through the base region to the interface with the collector region.

[0021] In particular, it can be seen that for the transistor HBT, when moving from its base region toward its collector region, there occurs a gradual slow decrease of its energy gap (E_g) which can be regarded as an effect of spatial modulation of the energy gap. This modulation is obtained by suitable implantation profiles of the germanium (Ge) atomic species whose concentration is maximal at the collector-base interface and minimal or almost nil at the emitter-base interface.

[0022] An active zone bias of the bipolar transistor HBT conforming with the above band curve allows of faster injection of the carriers from the emitter region, thereby greatly reducing their passage time.

[0023] The net result is a markedly increased cut-off frequency (f_T) of the HBT transistor and a decreased proportion of carriers trapped within the base.

[0024] Thus, for HBT transistors biased with collector currents in the milliampere range, high cut-off frequency values can be obtained which would not be achievable by conventional bipolar technology.

[0025] The $\text{Ge}_x\text{Si}_{1-x}$ heterostructure provided between the base and collector regions enables the P-doping of the base region to be increased, thereby lowering the value of the intrinsic resistance R_{bb} in the base region that restricts the applications of bipolar transistors at high frequencies.

[0026] A previously mentioned method of conventionally forming the HBT transistor with a $\text{Ge}_x\text{Si}_{1-x}$ heterostructure

will now be described with reference, in particular, to FIGS. 3a-3f. The same reference numerals used for similar elements in FIG. 1 have been retained for convenience.

[0027] FIG. 3a shows a crystalline silicon substrate 1 which has been doped with impurities of the N type and formed with a window 10 by selective deposition of a protective material 11. This protective material comprises a material layer, including impurities of the P type, which is deposited over the substrate and insulated by a dielectric capping.

[0028] A first implantation of germanium (Ge) is carried out through this window 10, and is followed by a second implantation of acceptor impurities, such as boron (B) atoms or BF_2^+ ions.

[0029] Thereafter, a step of re-construction of the crystal lattice of the substrate 1 is carried out by an RTA (Rapid Thermal Annealing) process, or a conventional thermal process in an oven, which is also applied to aid in driving the implanted ions into sites freed in the crystal lattice.

[0030] The outcome of this re-construction step is shown in FIG. 3b, where a planar base region 3, extending at the window 10 to a sufficient depth to allow of the subsequent creation of an emitter region, is highlighted for the first time.

[0031] Simultaneously with the formation of the base region 3 in the substrate 1, a collector region 2 is defined which is incorporated to the remaining portion, not implanted with P-type impurities, of the substrate 1.

[0032] The base region, extending as far as the interface to the collector region 2, will presently feature a $\text{Ge}_x\text{Si}_{1-x}$ heterostructure formed during the first implanting step and characterized by an energy band curve of the kind shown in FIG. 2.

[0033] From now on, as shown in FIG. 3c, the processing over the substrate 1, at the location of the window 10 and the protective material 11, will see the following successive operations:

[0034] thermal growth of a first thin dielectric layer 12 of silicon dioxide (SiO_2);

[0035] deposition of a second dielectric layer 14, typically of silicon nitride (Si_3N_4), onto the first thin dielectric layer 12;

[0036] deposition of a polysilicon layer 15.

[0037] To provide an emitter region at the location of the window 10 in the substrate 1, the process for fabricating the HBT transistor comprises a first chemio-physical etching (RIE) step and a second etching step, respectively of the polysilicon layer 15 and the second dielectric layer 14, to partially form isolation spacers at the edges of the window 10, as shown in FIG. 3d.

[0038] A third wet etching step of the remaining portions of the polysilicon layer 15, and a fourth etching step of the first thin dielectric layer 12 only, bring to completion the formation of the spacers 50, thereby exposing the base region 3 again, as shown in FIG. 3e.

[0039] The HBT transistor with $\text{Ge}_x\text{Si}_{1-x}$ heterostructure can now be completed by conventional processes for the

formation of an emitter region 4 accommodated within the base region 3 and overlaid by a corresponding emitter contact 9.

[0040] FIG. 3f is a general view of the HBT transistor with $\text{Ge}_x\text{Si}_{1-x}$ heterostructure being provided with an emitter contact 9 which comprises a first polysilicon layer 7 heavily doped with impurities of the N type and metallized on top by a layer 8.

[0041] The HBT transistors with $\text{Ge}_x\text{Si}_{1-x}$ heterojunction fabricated with the above process have revealed upon testing a behavior of the base current which is less than ideal.

[0042] This deviation from the ideal is brought out by the graph of FIG. 4, where the collector and base currents are plotted versus the voltage V_{be} between the base and the emitter, for two different HBT transistors formed on a common substrate.

[0043] The HBT transistors (T1, T2) in question have values (A_{t1} , A_{t2}) of their emitter surface areas of $2 \times 7.4 \mu\text{m}^2$ and $0.4 \times 7.4 \mu\text{m}^2$, respectively, resulting in a ratio (A_{t1}/A_{t2}) of five between their emitter areas and a ratio ($pt1/pt2$) of 1.2 between the outer perimeters of their emitter regions.

[0044] On the graph, the curves relating to the transistor T1 are full lines, and those relating to the transistor T2 are broken lines.

[0045] It can be seen from the graph that the base currents (those having flatter curves) of T1 and T2 differ little from each other, although the ratio (A_{t1}/A_{t2}) of their emitter areas is of five.

[0046] This brings out the existence of a non-ideal component for the base current which is unaffected by changes in the emitter surface area. This deviation from the ideal, well recognized in the art, has been attributed heretofore to attempts of the $\text{Ge}_x\text{Si}_{1-x}$ heterostructure, regarded as being responsible for re-combination phenomena within the semiconductor substrate, to relax.

BRIEF SUMMARY OF THE INVENTION

[0047] An embodiment of this invention is directed to a transistor with $\text{Ge}_x\text{Si}_{1-x}$ heterostructure, which can overcome the limitations described hereinabove so as to further improve its frequency performance.

[0048] The inventors of this invention recognized that the cause for HBT transistors deviating from the ideal is because of surface re-combination phenomena, rather than recombination phenomena reputedly occurring within the $\text{Ge}_x\text{Si}_{1-x}$ heterostructure.

[0049] Such surface re-combination phenomena have been found to occur in the neighborhood of the interface between the crystalline semiconductor substrate, incorporating a HBT transistor, and a thin layer of silicon dioxide (SiO_2) grown to aid in the formation of the spacers near an emitter region.

[0050] In one embodiment, the transistor is formed by a process that includes the steps of: defining a window in the semiconductor substrate; providing a first implantation of germanium atoms through said window; providing a second implantation of acceptor dopants through said window to define a base region; applying an RTA (Rapid Thermal Annealing) treatment to re-construct the crystal lattice

within the semiconductor substrate comprising a silicon/germanium alloy; forming a dielectric layer by chemical vapor deposition; forming spacers at window edges; forming an emitter region in the substrate through the window; and forming an emitter contact region.

[0051] The features and advantages of the transistor according to the invention will be apparent from the following description of an embodiment thereof, given by way of non-limitative example with reference to the accompanying drawings.

BRIEF DESCRIPTION OF THE SEVERAL VIEWS OF THE DRAWINGS

[0052] FIG. 1 is an enlarged cross-sectional view of a semiconductor substrate which integrates a high-mobility NPN transistor with a vertical structure including a $\text{Ge}_x\text{Si}_{1-x}$ heterostructure, according to the prior art.

[0053] FIG. 2 is an energy band plot typical of a high-mobility NPN transistor;

[0054] FIGS. 3a-3f illustrate conventional process steps yielding the high-mobility NPN transistor shown schematically in FIG. 1.

[0055] FIG. 4 is a voltage vs. current plot illustrating the behavior of the base and collector currents for two high-mobility NPN transistors T1 and T2 with a $\text{Ge}_x\text{Si}_{1-x}$ heterostructure having a ratio A_{t1}/A_{t2} of 5 of their respective emitter areas.

[0056] FIG. 5 is an enlarged cross-sectional view of a semiconductor body of crystalline silicon as implanted to provide a $\text{Ge}_x\text{Si}_{1-x}$ heterostructure, which has been subjected to an oxidation step for growing a silicon dioxide layer thereon.

[0057] FIG. 6 is a photograph taken by Atomic Force Microscopy (AFM), which shows an $\text{SiO}_2/\text{Ge}_x\text{Si}_{1-x}$ interface of a conventionally made transistor.

[0058] FIG. 7 is a plot illustrating the dependence of surface roughness at an $\text{SiO}_2/\text{Ge}_x\text{Si}_{1-x}$ interface on the amount of germanium segregated in the interface itself.

[0059] FIG. 8 illustrates a similar situation to that of FIG. 7, but relating to a practical instance of a high carrier mobility transistor also having an $\text{SiO}_2/\text{Ge}_x\text{Si}_{1-x}$ interface.

[0060] FIGS. 9a-9f illustrate the process steps according to this invention that yield a high-mobility NPN transistor similar to that shown schematically in FIG. 1.

[0061] FIG. 10 shows an atomic force microphotograph of the $\text{SiO}_2/\text{Ge}_x\text{Si}_{1-x}$ interface of an HBT transistor of the present invention.

[0062] FIG. 11 is a plot showing the behavior of the collector and base currents versus the base-emitter bias voltage, for profiles of acceptor impurities in substrates integrating two different types of HBT transistors.

[0063] FIG. 12 is a plot of the collector current versus the collector-emitter bias voltage, for two different types of HBT transistors.

[0064] FIG. 13 is a plot of the concentration FIG. 10 is a photograph taken by Atomic Force Microscopy (AFM),

which shows an $\text{SiO}_2/\text{Ge}_x\text{Si}_{1-x}$ interface obtained with the fabrication process of this invention.

[0065] FIG. 14 is a plot of the cut-off frequency versus the collector bias current for two different types of HBT transistors.

DETAILED DESCRIPTION OF THE INVENTION

[0066] The inventors of the present invention have spotted the main cause of performance deviations from an ideal device which limit, for example, the performance of a high-mobility HBT transistor, in the surface re-combination phenomena that appear at the silicon dioxide-to-germanium/silicon heterostructure, $\text{SiO}_2/\text{Ge}_x\text{Si}_{1-x}$.

[0067] In order to provide experimental evidence of the above conclusion, the inventors have conducted a series of atomic force microscopy (AFM) analyses to photograph the situation at the $\text{SiO}_2/\text{Ge}_x\text{Si}_{1-x}$ interface and has gathered useful elements for evaluation.

[0068] These analyses have shown a situation of the kind schematically illustrated in FIG. 5, wherein, on a body 30 of crystalline silicon implanted to produce a $\text{Ge}_x\text{Si}_{1-x}$ heterostructure, a layer 33 of pure germanium develops subsequently to a step of growing a layer 32 of silicon dioxide on the crystalline body 30.

[0069] This layer 33 is trapped from beneath by the $\text{Ge}_x\text{Si}_{1-x}$ heterostructure, and from above, by the silicon dioxide layer 32. This can be explained in theory by that the step of growing the silicon dioxide (SiO_2) thermally, as carried out in direct contact with the $\text{Ge}_x\text{Si}_{1-x}$ heterostructure, causes the silicon (Si) atoms present at its top surface to be depleted upward, thereby promoting the formation of the layer 33 of pure germanium.

[0070] In so doing, the silicon dioxide layer 32 develops a surface roughness, due to the underlying germanium layer 33, which is responsible for the surface re-combination phenomena occurring at the $\text{SiO}_2/\text{Ge}_x\text{Si}_{1-x}$ interface.

[0071] This surface roughness is brought out by the atomic force microphotograph of FIG. 6, showing the surface of the silicon dioxide layer 32 after the thermal growth process.

[0072] FIG. 7 is a plot showing the linearly increasing dependence of the amount of segregated germanium in the layer 33 on the surface roughness (Rms) of the layer 32.

[0073] A similar situation to the above, for an $\text{SiO}_2/\text{Ge}_x\text{Si}_{1-x}$ interface, is encountered where a high carrier mobility bipolar transistor (HBT) having a vertical structure with a $\text{Ge}_x\text{Si}_{1-x}$ heterostructure is fabricated by the process steps described under the Background of the Invention heading.

[0074] FIG. 8 is a cross-section through the high-mobility transistor of FIG. 1, with enlarged detail views of the emitter 4 and base 3 regions.

[0075] This figure highlights that the base and emitter regions are in direct contact with the isolation spacers 50 comprised of a first thin dielectric layer 12 of silicon dioxide and a second dielectric layer 14.

[0076] It is to be emphasized, therefore, that a $\text{Ge}_x\text{Si}_{1-x}$ heterostructure is present within the base region 3 wherever

the first thin dielectric layer **12** of silicon dioxide comprising both isolation spacers **50** has been grown.

[0077] Accordingly, a narrow region of the $\text{SiO}_2/\text{Ge}_x\text{Si}_{1-x}$ interface has been marked with a heavy circle where the presence is displayed of a layer **90** of segregated germanium resulting from the thermal oxidation process employed for growing the first thin dielectric layer **12**.

[0078] To overcome the drawbacks connected with the $\text{SiO}_2/\text{Ge}_x\text{Si}_{1-x}$ interface which limit the performance of conventional high-mobility transistors (HBT), a process for fabricating the transistor according to this invention is proposed herein below with reference to **FIGS. 9a-9f**.

[0079] For convenient comparison of the present inventive process with the process described under the Background of the Invention heading, the same reference numerals have been used to denote similar items with those shown in **FIGS. 1 and 3a-3f**.

[0080] **FIG. 9a** shows a substrate **1** of crystalline silicon (Si), lightly doped with impurities of the N type and having a bottom region **5** which is heavily doped with impurities of the N type. This bottom region **5** corresponds to the ohmic region of a collector contact (not shown here).

[0081] A window **10** is formed above the substrate **1** by selective deposition of a protective material **11** over the substrate **1**. This protective material **11** comprises a first layer in direct contact with the substrate **1** wherein acceptor impurities are embedded and which is capped by a dielectric material.

[0082] A first step of implanting germanium (Ge) is carried out through this window **10**, followed by a second step of implanting acceptor impurities, such as boron (B) atoms or BF_2^+ ions.

[0083] Thereafter, the crystal lattice of the substrate **1** is re-constructed by an RTA (Rapid Thermal Annealing) process or a conventional treatment in an oven, also is intended to aid in the insertion of the implanted atoms into sites left free in the crystal lattice.

[0084] The outcome of the last-mentioned step is shown in **FIG. 9b**, where a planar base region **3**, extending at the window **10** to a sufficient depth in the substrate **1** to allow of the subsequent creation of an emitter region, is highlighted for the first time.

[0085] Simultaneously with the definition of the base region **3** in the substrate **1**, a collector region **2** is defined which is included in the remaining portion, not implanted with acceptor impurities, of the substrate **1** and, accordingly, also contains the collector ohmic contact region **5**.

[0086] The base region, extending as far as the interface to the collector region **2**, will presently exhibit an energy band curve of the kind shown in **FIG. 2** as a result of a $\text{Ge}_x\text{Si}_{1-x}$ heterostructure having been formed during the first implanting step.

[0087] At this stage, as shown in **FIG. 9c**, at the location of the window **10** and the protective material **11**, a first thin dielectric layer **12'** of silicon dioxide (SiO_2) will be formed over the substrate **1** by chemical vapor deposition (CVD). Other types of CVD, such as PECVD, APCVD, LPCVD, UV-assisted CVD, could also be used.

[0088] Unlike the prior art, this thin dielectric layer **12'** of silicon dioxide is formed by a CVD process, not by a thermal growth process.

[0089] This provides an improved $\text{SiO}_2/\text{Ge}_x\text{Si}_{1-x}$ interface, as can be seen in **FIG. 10** which shows an atomic force microphotograph of the $\text{SiO}_2/\text{Ge}_x\text{Si}_{1-x}$ interface thus obtained.

[0090] It can be seen that the roughness of the $\text{SiO}_2/\text{Ge}_x\text{Si}_{1-x}$ interface shown in **FIG. 10** is significantly less than that in **FIG. 6** where the silicon dioxide was grown by thermal oxidation.

[0091] Excellent results, as regards to the formation of the $\text{SiO}_2/\text{Ge}_x\text{Si}_{1-x}$ interface, were also obtained by depositing the first thin dielectric layer **12'** of silicon dioxide by an atmospheric pressure chemical vapor deposition (APCVD) process.

[0092] To further enhance the quality of the interface, and thus reduce the faults originating local surface re-combination phenomena, it is contemplated that a thermal process should follow the deposition of the first thin dielectric layer **12'**.

[0093] The process for fabricating a HBT transistor according to the an embodiment of the invention is carried on through conventional steps including the deposition of a second dielectric layer **14** on top of said first thin dielectric layer **12'**, followed by the deposition of a polysilicon layer **15**.

[0094] In a first alternative embodiment, the second dielectric layer comprises silicon nitride (Si_3N_4) to ensure proper adhesion on the underlying dielectric layer **12'**.

[0095] Finally, to form an emitter region in the substrate **1**, at the location of the window **10**, a first chemio-physical etching (RIE) step will be carried out on the polysilicon layer **15**, and a second etching step on the second dielectric layer **14**, to obtain the partial formation of isolation spacers at the edges of the window **10**, as shown schematically in **FIG. 9d**.

[0096] A third, wet etching step carried out on the remaining portions of the polysilicon layer **15** and a fourth etching step carried out on just the first thin dielectric layer **12'** will complete the formation of the spacers **50**, thereby exposing the base region **3** again, as shown in **FIG. 9e**.

[0097] The HBT transistor formed according to the teachings of this invention can then be completed with conventional processes to form an emitter region **4** within the base region **2**.

[0098] Finally, the emitter region **4** will be overlaid with a corresponding top emitter contact **9**, optimized to enhance the injection efficiency of the HBT transistor.

[0099] **FIG. 9f** is a comprehensive view showing the HBT transistor with a $\text{Ge}_x\text{Si}_{1-x}$ heterojunction and the emitter contact **9** comprising a first polysilicon layer **7**, heavily doped with impurities of the N type and capped by a metal layer **8**.

[0100] A second alternative embodiment of the inventive process for fabricating HBT transistors will now be described and comprises processing steps which are identi-

cal with those described above up to the moment of forming the first thin dielectric layer **12'** of silicon dioxide.

[0101] In this second alternative embodiment, the first thin dielectric layer of silicon dioxide is replaced by a thick dielectric layer of silicon dioxide (SiO_2) also deposited by chemical vapor deposition (CVD).

[0102] In this embodiment, the thick dielectric layer of silicon dioxide could also be deposited by an APCVD process, followed by an optional thermal process.

[0103] The steps of the second alternative embodiment of the fabrication process include: depositing a layer **15** of polysilicon; etching inside the window region; and forming an emitter region overlaid by an electric contact, similar to the first embodiment described.

[0104] Also within the principle of this invention, a third alternative embodiment of the HBT transistor fabrication process will now be disclosed which includes the same process steps as those previously described up to the moment of forming the first thin dielectric layer **12'**.

[0105] In this third alternative embodiment, the first thin dielectric layer **12'** is formed by depositing a sacrificial silicon (Si) layer and then subjecting it to thermal oxidation. This sacrificial layer is deposited inside the window region **10** in direct contact with the $\text{Ge}_x\text{Si}_{1-x}$ heterostructure included in the substrate **1**.

[0106] Advantageously, the process steps described for forming the first thin dielectric layer **12'** by a sacrificial layer will yield the same results, in terms of quality of the $\text{SiO}_2/\text{Ge}_x\text{Si}_{1-x}$ interface, as were obtained previously by forming the layer **12'** with a chemical vapor deposition (CVD) process.

[0107] It has been found that the sacrificial layer deposited inhibits the formation of the occluded germanium layer between the heterostructure and the first thin dielectric layer **12'** because it prevents the oxidation process from reaching the $\text{Ge}_x\text{Si}_{1-x}$ heterostructure.

[0108] In order to further minimize the surface re-combination phenomena that occur at the $\text{SiO}_2/\text{Ge}_x\text{Si}_{1-x}$ interface, the third alternative embodiment of the process may also have the step of forming the thin dielectric layer **12'** followed by a suitable thermal treatment.

[0109] The steps of the third alternative embodiment of the HBT transistor fabrication process will then include: depositing a second dielectric layer **14**; depositing a layer **15** of polysilicon; etching inside the window region; and forming an emitter region overlaid by an electric contact, similar to the first embodiment described.

[0110] To improve the adhesion of the second dielectric layer **14** on the first thin dielectric layer **12'**, the second dielectric layer may comprise silicon nitride (Si_3N_4).

[0111] Again within the principle of this invention, a fourth alternative embodiment of the HBT transistor fabrication process is provided which includes processing steps identical with those previously described in relation to the third alternative embodiment up to the moment when the first thin dielectric layer **12'** is formed.

[0112] In this embodiment, the first dielectric layer of silicon dioxide is further grown thermally to provide a

dielectric layer of increased thickness embedding, or replacing, the second dielectric layer **14**.

[0113] In order to minimize the surface re-combination phenomena that occur at the $\text{SiO}_2/\text{Ge}_x\text{Si}_{1-x}$ interface, the fourth alternative embodiment of the HBT transistor fabrication process may also have the oxidation step followed by a suitable thermal treatment.

[0114] The next steps of the fourth alternative embodiment of the fabrication process will include: depositing a layer **15** of polysilicon; etching inside the window region; and forming an emitter region overlaid by an electric contact, similar to the second embodiment described.

[0115] Advantageously, by adopting the fabrication processes of this invention, the technical problem of the base current deviating from the ideal in HBT transistors can be solved.

[0116] The truth of this statement is brought out by the graph in **FIG. 11** which illustrates the behavior of the collector (Ic) and base (Ib) currents versus bias voltage (Vbe), as applied between the base and the emitter, for two HBT transistors having the same emitter surface area but formed with different fabrication methods. In fact, two patterns can be distinguished on this graph: the one (broken line) associated with the HBT transistor which has the dielectric layer **12** grown by thermal oxidation, and the other (full line) associated with the HBT transistor formed by the process of this invention with the dielectric layer **12'** deposited by CVD. These two patterns nearly match each other, and this match reveals a marked reduction in the deviation of the base current from the ideal.

[0117] **FIG. 12** shows, for the same types of HBT transistors as above, the behavior of their respective collector currents (Ic) versus the bias voltage (Vce) across the collector and emitter.

[0118] It is evinced from this graph that, for HBT transistors fabricated by the process of the invention (full line curve), a significant increase occurs in the variation percent of the current gain versus the collector current. It should be also emphasized that these transistors have lower saturation voltage values, thereby affording lower power consumption.

[0119] Another advantage of the fabrication process of this invention or its first embodiment (CVD deposition of the layer **12'**) is that it involves relatively low deposition temperatures. This prevents back diffusion of the implanted acceptor impurities, thereby avoiding an oxidation-enhanced diffusion of boron and further raising the cut-off frequency of the HBT transistor fabricated by the process of this invention.

[0120] A confirmation of the above statements can be found in the graphs of **FIG. 13** and **FIG. 14** which show, for the two types of HBT transistors described above, the concentration profile of the acceptor impurities versus depth into the substrate and the behavior of the cut-off frequency versus the collector bias current.

[0121] Finally, notice that collector bias currents in the milliamperage range allow HBT transistors fabricated with the invention process to attain cut-off frequencies in the 20 GHz range, that is hitherto unattainable values.

[0122] In conclusion, the fabrication process of this invention allows the frequency field of application of HBT

transistors to be further extended, while eliminating deviations of the base current from the ideal.

[0123] From the foregoing it will be appreciated that, although specific embodiments of the invention have been described herein for purposes of illustration, various modifications may be made without deviating from the spirit and scope of the invention. Accordingly, the invention is not limited except as by the appended claims.

[0124] All of the above U.S. patents, U.S. patent application publications, U.S. patent applications, foreign patents, foreign patent applications and non-patent publications referred to in this specification and/or listed in the Application Data Sheet are incorporated herein by reference, in their entirety.

1. A heterostructure bipolar transistor, comprising:
 - a substrate comprised of a first semiconductor material doped with impurities of a first type, the substrate including a first conducting region;
 - a heterostructure alloy region positioned in the substrate and comprised of a heterostructure alloy of atoms of the first semiconductor material and atoms of a second semiconductor material;
 - a base region positioned in the substrate above the first conducting region and doped with impurities of a second type;
 - a first dielectric layer positioned on the substrate, the first dielectric layer defining a first window directly above the heterostructure alloy region;
 - a second conducting region positioned in the heterostructure alloy region and between the first window and the base region, the second conducting region being comprised of the heterostructure alloy doped with impurities of the first type; and
 - a contact region positioned in the first window and comprised of the first semiconductor material, the contact region directly contacting the heterostructure alloy of the second conducting region in the heterostructure alloy region.
2. The transistor of claim 1 wherein the first dielectric layer directly contacts the heterostructure alloy of the of the heterostructure alloy region.
3. The transistor of claim 1, further comprising:
 - a protective layer positioned over the semiconductor substrate and defining a second window above the heterostructure alloy region, the first dielectric layer being positioned in the second window between the protective layer and the first window.
4. The transistor of claim 3, further comprising a second dielectric layer positioned on the first dielectric layer and in the second window between the protective layer and the first window.
5. The transistor of claim 4 wherein the first dielectric layer is silicon dioxide and the second dielectric layer is silicon nitride.
6. The transistor of claim 1 wherein the first semiconductor material is silicon, the second semiconductor material is germanium.
7. The transistor of claim 1, further comprising a metal contact formed directly on the contact region.
8. A heterostructure bipolar transistor, comprising:
 - a substrate comprised of a first semiconductor material doped with impurities of a first type, the substrate including a first conducting region;
 - a heterostructure alloy region positioned in the substrate and comprised of a heterostructure alloy of atoms of the first semiconductor material and atoms of a second semiconductor material;
 - a base region positioned in the substrate above the first conducting region and doped with impurities of a second type;
 - a first dielectric layer positioned on, and directly contacting, the heterostructure alloy region, the first dielectric layer defining a first window directly above the heterostructure alloy region; and
 - a second conducting region positioned in the heterostructure alloy region and between the first window and the base region, the second conducting region being comprised of the heterostructure alloy doped with impurities of the first type and directly contacting the first dielectric layer.
9. The transistor of claim 8, further comprising:
 - a protective layer positioned over the semiconductor substrate and defining a second window above the heterostructure alloy region, the first dielectric layer being positioned in the second window between the protective layer and the first window.
10. The transistor of claim 9, further comprising a second dielectric layer positioned on the first dielectric layer and in the second window between the protective layer and the first window.
11. The transistor of claim 10 wherein the first dielectric layer is silicon dioxide and the second dielectric layer is silicon nitride.
12. The transistor of claim 8 wherein the first semiconductor material is silicon, the second semiconductor material is germanium.
13. The transistor of claim 8, further comprising:
 - a contact region positioned in the first window and comprised of the first semiconductor material, the contact region directly contacting the heterostructure alloy of the second conducting region in the heterostructure alloy region; and
 - a metal contact formed directly on the contact region.
14. A vertical structure high carrier mobility bipolar transistor, comprising substrate of crystalline silicon doped with impurities of the N type, having a collector region located at a lower portion of the substrate, the transistor being obtained by a process that includes:
 - defining a window above the substrate;
 - providing a first implantation of germanium atoms through said window into the substrate;
 - providing a second implantation of acceptor dopants through said window to define a base region in the substrate;
 - applying an RTA treatment, or treatment in an oven, to re-construct a crystal lattice within the semiconductor substrate comprising a silicon/germanium alloy;

forming by chemical vapor deposition a first thin dielectric layer of silicon dioxide on the substrate;

depositing a second dielectric layer onto said first dielectric layer;

depositing a polysilicon layer onto said second dielectric layer;

etching away, within the window region, said first and second dielectric layers, and the polysilicon layer, to expose the base region and form isolation spacers at edges of the window; and

forming an N-doped emitter in the base and window regions.

15. The transistor of claim 14 wherein the deposition of the first thin dielectric layer of silicon dioxide is carried out by an atmospheric pressure chemical vapor deposition process.

16. The transistor of claim 14 wherein the deposition of the first thin dielectric layer of silicon dioxide is followed by thermal treatment.

17. The transistor of claim 14 wherein the second dielectric layer is silicon nitride.

18. The transistor of claim 14 wherein the emitter directly contacts the first dielectric layer.

* * * * *